

DESIGN AND ASSEMBLING OF A LOW COST  
TRANSISTORISED RADIO AND CONSTRUCTION  
OF SOME OF ITS COMPONENTS

BY

HAFIZ FARUQUE AHMED SHARIF B.Sc. ENGG. (ELECT)

A Thesis

Submitted to the Department of Electrical Engineering  
in partial fulfilment of the requirements for the Degree  
of Master of Science in Electrical Engineering.

Bangladesh University of Engineering and Technology, Dacca.

September, 1974

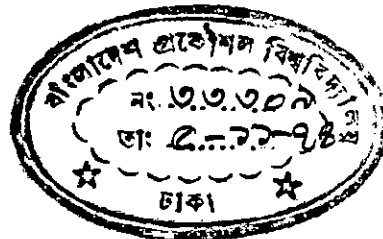

#33309#

MEMBERS OF THE EXAMINATION COMMITTEE.

1. Dr. M. Hasibur Rahman, Chairman,  
Associate Professor of E.E. Deptt. B.U.E.T. Dacca.
2. Mr. Aziz Khandakar, External Member.  
Project Manager, Meher Industries, Dacca.
3. Dr. A.M. Zahoorul Huq, Member.  
Professor and Head, E.E. Deptt. B.U.E.T. Dacca.
4. Dr. Solaimanul Mahdi, Member.  
Associate Professor of E.E. Deptt. B.U.E.T. Dacca.

Accepted as satisfactory for partial fulfilment of  
the requirements for the degree of Master of Science in  
Engineering (Electrical)

Examiners

- (I) M. Rahman 13/9/74  
(II) M. Aziz 13/9/74  
(III) A. Zahid 13/9/74  
(IV) S. A. M. M. M.

This is to certify that this work was done by me and  
it has not <sup>been</sup> submitted elsewhere for the award of any degree or  
diploma.

Countersigned

msb 13/9/74  
Supervisor

S. Ahmed 12.7.74  
Signature of the candidate.

## ABSTRACT

Simple transistorised radio receiver circuits have been designed and assembled with the components available in the local market. To reduce the cost some of the components such as the antenna coil, oscillating coil, intermediate frequency transformer, input-output transformers and driver transformer are designed and constructed. It has been found that the price per set of radio using such self made components can be brought down by about 20%. If the components such as ferrites, resistors, capacitors and transistors are manufactured through an electronic component industry, the price per set can further be reduced by another 35%. The technique of design, construction and manufacturing process of the above mentioned radio components are described in details.

The thesis also describes the feasibility study of an electronic component manufacturing plant which may be helpful for an industrialist to establish such a plant in Bangladesh.

### ACKNOWLEDGEMENT

The author expresses his indebtedness<sup>ed</sup> and deep sense of gratitude to his supervisor, Dr. Hasibur Rahman, Associate Professor of Electrical Engineering, Bangladesh University of Engineering and Technology, Dacca, for his constant encouragement and valuable guidance throughout the course of this work.

The author also extends his heartfelt thanks to Mr. Aziz Khandoker, project manager of Meher industries, Bangladesh and author's brother, Mr. Rafiqul Islam Sharif, a student of Ph.D in the Department of Applied Physics, University of Durham, England for their kind advice, valuable suggestion and providing him with journals from time to time.

Finally, the author expresses his sincere gratitude and thanks to Dr. A.M. Zahoorul Haq, Professor and Head of the Department of Electrical Engineering for the facilities provided in the Department and to Dr. Solaimanul Mahdi who inspires him in continuing his study.

## TABLE OF CONTENTS

		<u>Page</u>
Chapter I	Introduction	
1.1	Importance of Radio	1
1.2	Review of Past work	1
1.3	Objective of this study	2
Chapter II	Design of low cost Radio Receiver Sets	
2.1	Design of tuned radio frequency receiver	3
2.2	Design of Superhetrodyne receiver	10
Chapter III	Design and Construction of some Radio Components	
3.1	Antenna Coil	16
3.2	Oscillating Coil	20
3.3	IF Transformer	26
3.4	Input-Output transformer	36
3.5	Ferrites	44
3.6	Resistors	53
3.7	Capacitors	58
3.8	Transistors	65
Chapter IV	Feasibility study of Electronic Component manufacturing plant	75
4.1	Introduction	
4.2	Description of Electronic Industries of South East Asian countries	75
4.3	Discussion	77
4.4	Investment cost of plant	79
4.5	Conclusion	79
Chapter V	Results and Discussion	
5.1	General	81
5.1.1	T.R.F.	81
5.1.2	Superhetrodyne	83
5.2	Cost analysis	83
5.2.1	Cost analysis of TRF	84
5.2.2	Cost analysis of Superhetrodyne	86
Chapter VI	Conclusion	
6.1	General	88
6.2	TRF	88
6.3	Superhetrodyne	88
6.4	Electronic Component plant	89
Appendix 1	List of the Instruments used for research purpose in the BUET Electronics Laboratory	90
* 2	List of the Instruments used for research purpose in the BUET Microwave Laboratory	93
* 3	Characteristics of Copper Conductor SWG	96
Bibliography		97

## LIST OF FIGURES & CURVES

	<u>Page</u>
1. Tuned radio frequency receiver circuit (2.1)	8
2. Superhetrodyne receiver circuit (2.2)	12
3. Aerial tuning circuit (3.1)	16
4. Equivalent circuit of an aerial (3.2)	16
5. Typical ferrite rod (3.3)	17
6. Oscillator circuit (3.4)	21
7. Modified Oscillator Circuit (3.5)	21
8. Circuit of Trimer & Padder capacitance (3.6)	22
9. Error/Frequency curve (3.7)	22
10. Equivalent network of inductively coupled IF Transformer circuit (3.8)	26
11. Input-Output Impedance Circuit of a Transistor OC 45 (3.9)	29
12. Equivalent network of the output circuit of a transistor with $V_b$ shorted (3.10)	29
13. Equivalent Circuit of Transistorised IF Transformer (3.11)	32
14. Pushpull Stage with Transformer (3.12)	36
15. Single Characteristics Analysis for Class B Pushpul Performance (3.13)	37
16. Distorsion Factor Curve for Stalloy (3.14)	41
17. Input-Output Transformer with Pushpull T. (3.15)	42
18. Frequency Curve of ferrite (3.16)	45
19. Typical Magnetization Curves of Ferrites (3.17)	45
20. Electrolytic Aluminium Capacator (3.18)	61
21. PNP & NPN Transistor (3.19)	65
22. Fabrication process of alloy junction Transistor (3.20)	65
23. Idealized alloy transistor structure (3.21)	66
24. Pictorial representation of symbol of Alloy Transistor (3.22)	75
25. Demand Vs. no. of band radios in villages	80
26. Demand Vs. no. of band radios in cities	80



LIST OF TABLES

		<u>Page</u>
1. Values of residual, eddy current & hysteresis loss coefficients of different ferrites	(3.5.1)	49
2. Values of radius, Ions and P of ferrite materials	(3.5.2)	50
3. Characteristics of screw ferrite manufactured by Semi-conductor Ltd., India	(3.5.3)	50
4. Characteristics of Rod ferrites manufactured by Mullard	(3.5.4)	51
5. Classification of Ceramic capacitor	(3.7.1)	60
6. Rapid Expansion of Singapore Electronic Industry	(4.3.1)	76
7. Expansion of Hongkong Electronic Industry	(4.3.2)	76
8. Population per capita <del>income</del> national income and Radio sets used in different countries	(4.3.3)	78
9. Imported figures of electronic components in 1973 to Bangladesh	(4.3.4)	78
10. Annual demand of radio sets and estimated demand for its components	(4.3.5)	79
11. Investment cost of an electronic component plant	(4.3.6)	79
12. Currents and voltages of different transistors in the TWF receiver	(5.1)	82
13. Currents and voltages of different transistors in the Superhetrodyne receiver	(5.2)	83
14. Characteristics of Copper Conductors S.W.G.	(7.1)	96

LIST OF PHOTOGRAPHS

		<u>Page</u>
1. IF Transformer is being tested	(2.1)	8
2. TRF Receiver with Two Tuned Filter Circuit	(2.2)	9
3. Superhetrodyna Receiver set	(2.3)	13
4. Self-made a few Radio Components	(2.4)	14
5. A few Instruments used for Research purpose	(2.5)	15
6. Antenna Coil	(3.1)	19
7. Oscilleting Coil	(3.2)	25
8. IF Transformer	(3.3)	35
9. Input-Output Transformer	(3.4)	43

CHAPTER - 1

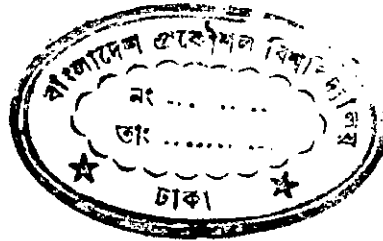

## INTRODUCTION

1.1. Importance of Radio : As eighty percent people of Bangladesh are illiterate, the newspaper and other news media cannot serve the means of communication between the Government and the people . Television is another means of communication but it is very costly and beyond the reach of common people. The only other means of communication that could serve the purpose is the radio. We have a 100 kw medium wave Radio Broadcasting station in Dacca which can be received by a one band M.W. Radio from any part of our country. But how would this broadcast be listened by this common people in rural areas comprising roughly 90% of the total population when a medium wave radio receiver costs not less than Tk. 400 now-a-days ? The cost per set should be brought down to the purchasing power of common people who never enjoy any fruits of modern science in this space age. Thus a need for the mass production of low cost radio receiver is felt.

1.2. Review of past work: No effort has so far been made in this respect for the production of low cost transistorised radios in Bangladesh. However, some electronic components such as resistors, capacitors, magnetic materials, rectifiers, transformer cores are reported to be developed in Bangladesh council of scientific and industrial research<sup>(1)</sup>. It is also reported that diodes and transistors are being fabricated in the Department of Applied Physics, Dacca University and in the Department of Electrical Engineering, Bangladesh University of Engineering and Technology. Facilities of manufacturing non-standard electronic components such as antenna coil, oscillating coil, If transformer, input-output transformers, cabinet etc. are available in Mehedi Industries, Dacca. Besides these components, some non standard mechanical components such as band switches, knob, dial etc. are being manufactured by Phillipe (Bangladesh) Ltd., Dacca, Facto- Yagnagan Electronics, Dacca, Radio Electronics stores, Chittagong and Universal Radio service, Chittagong. The Atomic Energy Centre, Dacca has the facility of manufacturing printed circuits.

The prospect of standard radio components manufacturing plant in Bangladesh is extremely high, because there is no other factory of its kind in this country. Before liberation there was only one component manufacturing plant

namely ELMAC <sup>(2)</sup> public limited company at Lahore, which used to meet some demands of erstwhile East Pakistan. The factory jointly owned by Philips, PICIC and a number of private investors was established in 1965 at a cost of Rs. 5.5 million and started production of a limited range of germanium transistors, diode, potentiometers, capacitors and resistors from 1967. In 1969 a market survey was undertaken by the EPIDC to set up an electronic equipment manufacturing plant in the then East Pakistan. The feasibility study made an important conclusion on the manufacturing of electronic components. "A Sound Component industry and a reliable source of supply of a wide range of components is of fundamental importance to the development of electronic industry. E.P.I.D.C. may wish to give consideration to the setting up of an organisation for electronic components as a means of aiding the development of electronic industry".

1.3. Objective of this study : In the present day world radios are no longer considered as luxury. They are now essential for mass education that lead to rapid cultural development. In many countries electronics industry has contributed towards national income to a great extent .From a survey result it has been found that a large no. of families showed a great interest in buying low cost radios. Two low cost transistorised radio circuits, one TRF and the other superheterodyne, have been designed and constructed (chap II). A study of the design and manufacturing process of electronic components has been made and discussed in chapter III. For the production of low cost transistorised receiver an electronic component manufacturing plant is necessary. A feasibility study for such an electronic component manufacturing plant has been made and discussed in chapter IV. The cost analysis of TRF and superheterodyne receiver has been given in chapter V. Conclusions have been given in chapter VI. A TRF receiver set has been assembled with some self made components and some directly imported components, where 70% cost reduction of a medium wave radio receiver has been achieved. Another superheterodyne receiver set has also been assembled with some self-made components and some directly imported components where 50% cost reduction has been achieved. It is also concluded that the price of radio components if manufactured locally will be one third of the price for the same components available in the local market.

CHAPTER - II

## 2.1 TUNED RADIO FREQUENCY RECEIVER

A low cost transistorised radio frequency receiver using five transistors and two tuned filter circuits is designed and assembled with some self made components and some components available in the local market. The number of components are reduced as far as possible.

Single resistor constant base biasing circuit has been used. This type of biasing does not provide the best interchangeability and stability but is used to provide the minimum no. of parts. For selectivity a minimum two tuned circuits are necessary with the antenna as the first tuned circuit and a small ferrite core tuned circuits of 690 kc/s or 670 kc/s as the second tuned circuit. First and 2nd transistors are resistance coupled to reduce complexity. The diode detector has a forward bias applied through  $R_1$  to improve both detector sensitivity and linearity. The detector output is applied by the volume control to the audio stages.

The TRF receiver circuit is shown in fig. 2.1.

### 2.1.1 DESIGN OF THE BIASING CIRCUIT

Transistor AF 115 (21),

$$\begin{aligned} \text{Given, } V_{CE} &= 6 \text{ V} \\ I_C &= 1 \text{ mA} \\ \beta &= 150 \\ f &= 10.7 \text{ mc/s} \\ &= \infty \end{aligned}$$

$$\frac{V_{CC}}{4} = 10 \quad V_{BE} = 2$$

$$V_{CC} = 8 \text{ volts}$$

Assuming  $R_E = 1.5 \text{ k } \Omega$

$$V_{CC} = V_{CE} + I_C (R_L + R_E) \quad \Rightarrow R_L = .5 \text{ k } \Omega$$

$$V_{CE} = \frac{V_{CC}}{1 + \frac{R_L}{R_F}} \quad \Rightarrow R_F = 225 \text{ k } \Omega$$

Suitable  $C_C$  and  $C_E$  are  $.10 \mu\text{f}$  and  $.02 \mu\text{f}$ .

Transistor 2SA 12 (20)

- $V_{CE} = 6$  volts
- $I_C = 2$  mA
- $\beta = 50$
- $I_B = 40 \mu A$

$V_{CC}$

$$\frac{V_{CC}}{4} = 10 V_{BE} = 2$$

$$V_{CC} = 8 \text{ volts}$$

Assuming  $R_E = 1 k$

$$R_B = \frac{V_{CC} - I_E R_E - V_{BE}}{I_B} = \frac{8 - 2.2}{40} = 150 k\Omega$$

Suitable  $C_C$  and  $C_E$  are  $.01 \mu f$  and  $.02 \mu f$ .

Transistor 2N 856 (54)

- Given  $V_{CE} = 6$  volts
- $I_C = 1.3$  mA
- $I_B = 15 \mu A$
- $\beta = 86$

$V_{CC}$

$$\frac{V_{CC}}{4} = 10 V_{BE} = 2$$

$$V_{CC} = 8 \text{ volts}$$

Assuming  $R_E = 1.5 k\Omega$  and  $R_2 = 10 k\Omega$



$$R_1 = \frac{V_{CC} - I_C R_C - V_{BE}}{(I_C R_E + V_{BE})/R_2 + I_B} \approx 25 \text{ k}\Omega$$

Transistor 2N 156 (20)

$$E_{DC} = 6 \text{ volts}$$

Load impedance collector to collector =  $86 \Omega$

$$R_E = 2 \Omega$$

Zero signal d.c. collector current per transistor. =  $2.5 \text{ mA}$

Collector load :- Let  $V_{CC}$  be reduced by  $.5 \text{ V}$

$$R_C = \frac{86}{4} = 22 \Omega$$

Total load on each transistor  $R_C + R_E = 24 \Omega$

$$\text{Total power } P_{o \text{ max}} = \frac{V_{CC}^2}{2(R_C + R_E)} = .686 \text{ watts}$$

$$\text{Useful power output} = P_{o \text{ max}} \times \frac{R_C}{R_C + R_E} = .630 \text{ watts}$$

$$\text{Now } R_1 + R_2 = \frac{V_{CC}}{2.5} = 2.4 \text{ k}\Omega$$

$$\text{Let } R_1 = 2.2 \text{ k}\Omega \quad R_2 = 200 \Omega$$

### 2.1.2 COIL DESIGN

ANTENNA COIL: (22)

$$L = .256 \mu\text{H}$$

$$Q = 265$$

$$N_1 = 64$$

$$B = 2 \text{ KC}$$

$$N_2 = 6$$

$$R = 3.22 \Omega$$

SWG 36

TUNED FILTER CIRCUITS (19) :

$$f = .670 \text{ kc/s}$$

$$L = 177 \mu\text{H}$$

$$C = 320 \text{ pf}$$

$$N_1 = 80 + 40$$

$$B = 30 \text{ kc}$$

$$N_2 = 20$$

SWG 38

b  $f = 690 \text{ kc/s}$   $L = 168 \mu H$   
 $N_1 = 76 + 38$   $C = 320 \text{ pf}$   
 $N_2 = 19$   $B = 30 \text{ kc}$   
 SWG .38

c  $f = 625 \text{ Kc/s}$   $L = 130 \mu H$   
 $N_1 = 90$   $C = 500 \text{ pf}$   
 $N_2 = 30$   $B = 35 \text{ KC}$   
 SWG 38

ferrite cores- Length = 1 cm  $D = .7 \text{ cm.}$

INPUT TRANSFORMER :

Core area = .5 cm  $\square$

$N_p = 1600$  SWG 42

$N_s = (500 + 500)$  SWG 40

OUTPUT TRANSFORMER : (3)

Core is stalloy 4% silicon.

$N_p = 164 + 164$  SWG 38

$N_{ss} = 122$  SWG 20  $R = 8 \Omega$

Core area = .75 cm.  $\square$

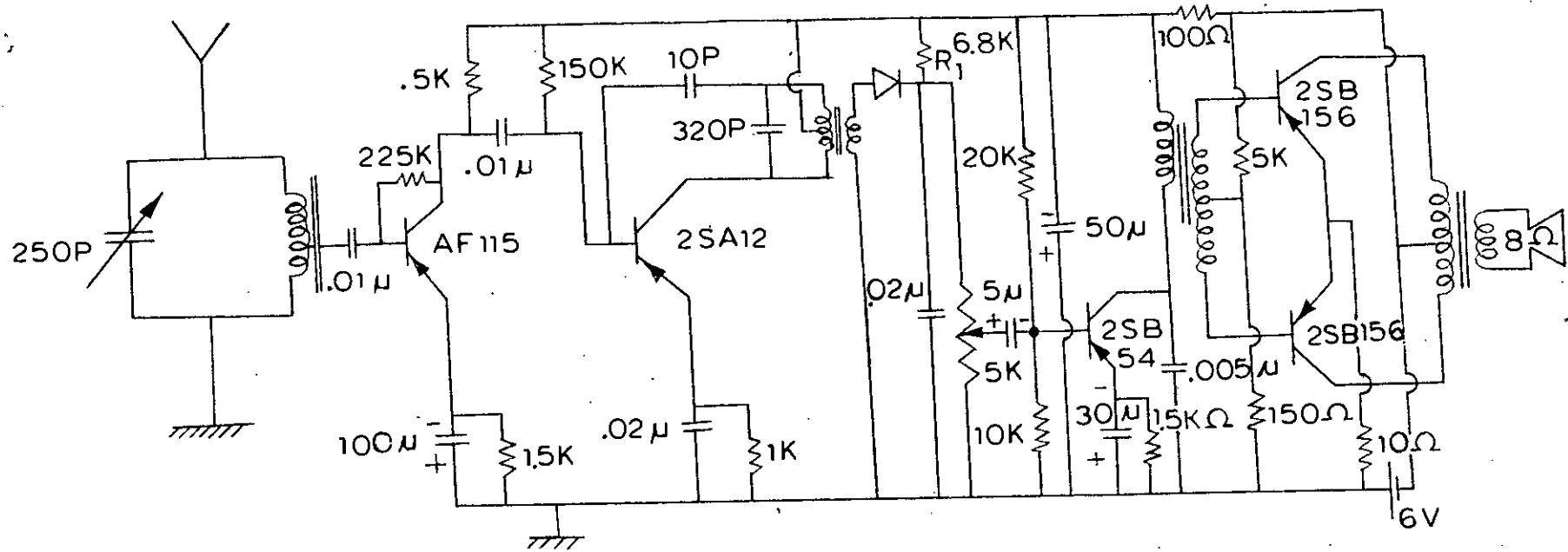

FIG. 2.1. TUNED RADIO FREQUENCY RECEIVER.

Battery 6 Volts

Tuned Filter Frequency 625kc/s

Frequency Range 530KHZ - 1620KHZ

Out put .625 Watt

Loud Speaker 8 Ω

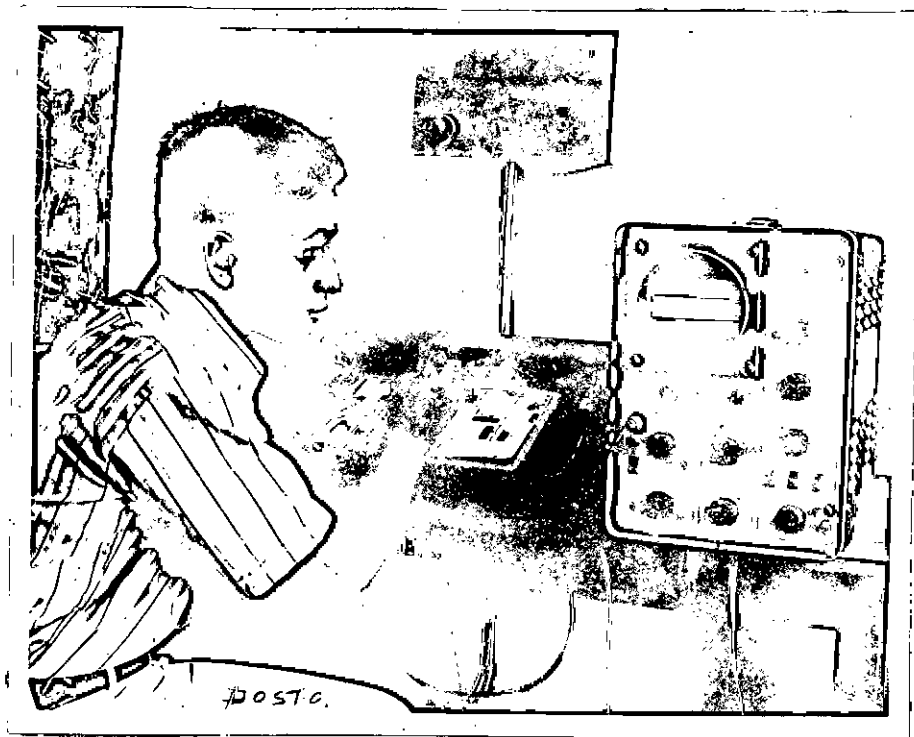

Photograph 2.1  
IF Transformer is being Tested.

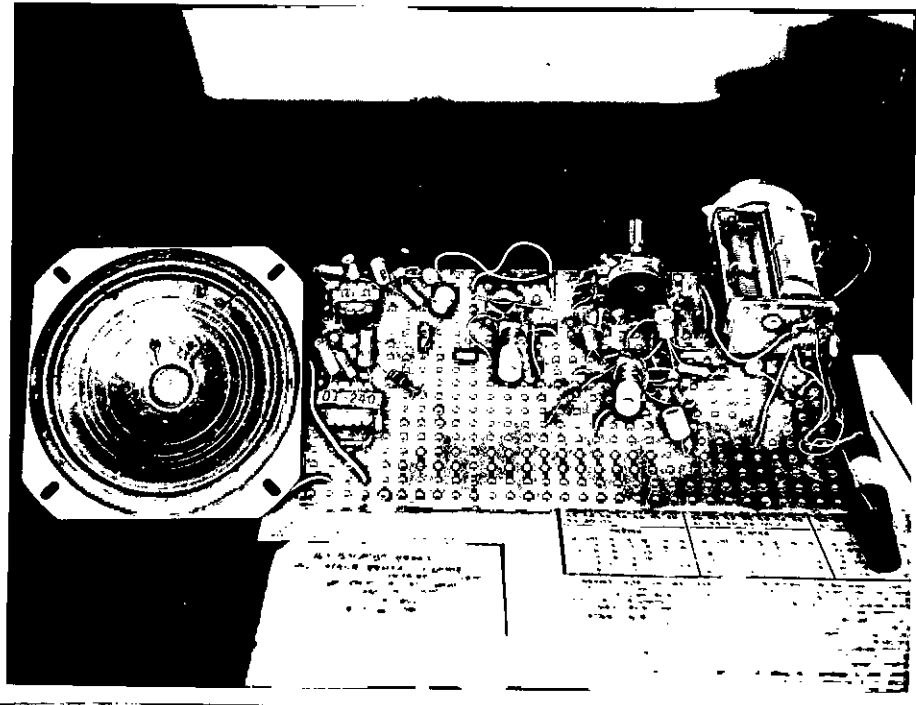

Photograph 2.2  
TRF Receiver with Tuned Filter Circuit

## 2.2 SUPERHETERODYNE RECEIVER

In this type of receiver the incoming signal is mixed with a locally generated signal to produce an intermediate frequency which is then amplified and demodulated. TRF receiver requires an aerial and in the presence of local strong signal weak signals can not be tuned. These difficulties may be overcome by superheterodyne receiver.

This superheterodyne receiver using 5 transistors, 2 IF transformers and a driver transformer has been designed and assembled. Transistors AF 115, OC 45 are used for maximum gain. A driver transformer has been used in place of input-output transformer to reduce the cost.

The circuit diagram for the superheterodyne receiver is given in Fig 2.2

### 2.2.1 DESIGN OF THE BIASING CIRCUIT:

Transistor OC 45<sup>(18)</sup>  $f_{\alpha} = 6 \text{ Mc/s}$   $V_{CE} = -6 \text{ volts}$ ,  $I_C = 1 \text{ mA}$ .

Assuming  $R_E = 820 \Omega$   $V_E = .82 \text{ volts}$ . For  $V_C = -6 \text{ V}$  and allowing for  $V_E$  and the voltage drop across the tuned circuit  $V_{CC} = -7\text{V}$ . Thus making  $V_B = -1 \text{ volt}$ .

$$\frac{7 R_2}{R_1 + R_2} = 1 \text{ and } 6 R_2 = R_1$$

Also making  $\frac{R_1 R_1}{R_1 + R_2} = 10 R_E = 8.2 \text{ k}\Omega$

Therefore,  $R_1 R_2 = 8.2 R_1 + 8.2 R_2$

$$6 R_2^2 = 49.2 R_2 + 8.2 R_2$$

$$6 R_2 = 57.4 \text{ K}\Omega$$

Let  $R_2$  be  $10 \text{ k}\Omega$  and hence  $R_1$  should be  $56 \text{ k}\Omega$  suitable decoupling capacitances are

$$C_E = .25 \mu\text{f}$$

$$\& C_C = .1 \mu\text{f}$$

Transistor AF 115<sup>(21)</sup> :  $V_{CE} = -6 \text{ V}$   $I_C = 1 \text{ mA}$   $f_{\alpha} = 10.7 \text{ Mc/s}$   $\beta = 150$

Assuming stability factor  $S=8$  and emitter drop  $5\%$ , Emitter voltage =  $1.2 \text{ V}$

$$R_E = 1.2 \text{ k}\Omega$$

$$I_C = 1 \text{ mA}$$

$$S = \frac{R_B}{R_E} \therefore R_B = 9.6 \text{ K}$$

$$I_C = \frac{(E_1 - E_0)}{R_B + R_E (1 + \beta)} \therefore E_1 = 1.65 \text{ V} \quad \therefore E_0 = .3 \text{ V}$$

$$\frac{E_1}{R_B} = \frac{E_{DC}}{R_1} \therefore R_1 = 32 \text{ k}\Omega \quad \& \quad R_B = \frac{R_1 R_2}{R_1 + R_2} \quad R_2 = 11.5 \text{ k}\Omega$$

Suitable decoupling capacitance are  $C_E = .25 \mu\text{f}$   
 $C_1 = .1 \mu\text{f}$

2.2.2 COIL DESIGN:

OSCILLATING COIL :-

Typical ferrite core 1/8" dia and length 1- 1/4"

$$N_p = 64 + 2$$

$$L = 88 \mu H$$

$$N_s = 12$$

S.W.G. 44

INTERMEDIATE FREQUENCY TRANSFORMER (19) :

$$N_p = 100 + 50$$

$$L = 500 \mu H$$

$$N_s = 28$$

$$C = 240$$

SWG 44

$$R = 6.3 \Omega$$

$$Q_p = 100$$

Typical ferrite core is used.

DRIVER TRANSFORMER :

Core area = .5 cm  $\Delta$  . Core is stalloy 4% silicon

SWG in the primary 44

SWG in the secondary 42

$$N_p = 1835$$

$$N_{s1} = 620$$

$$N_{s2} = 620$$

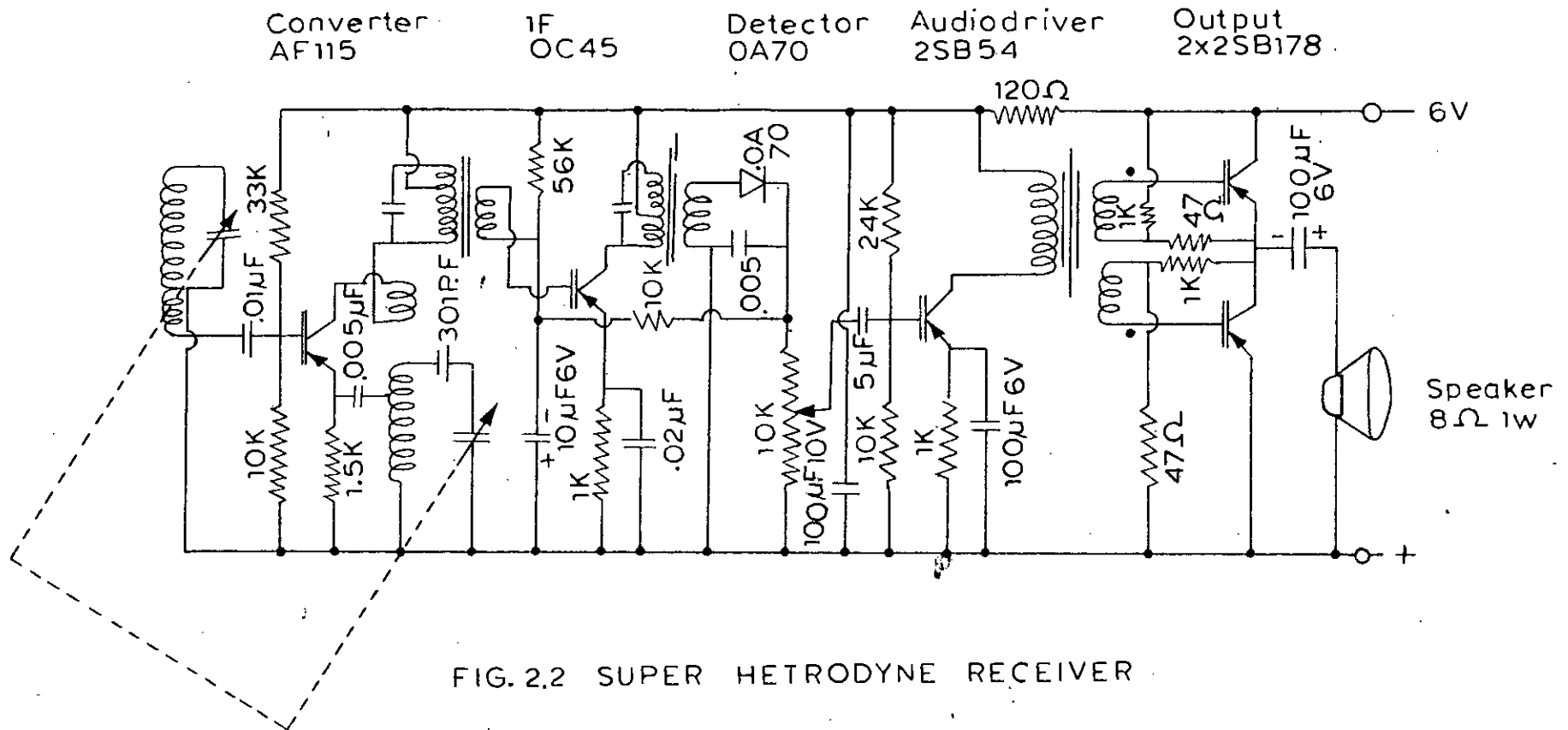
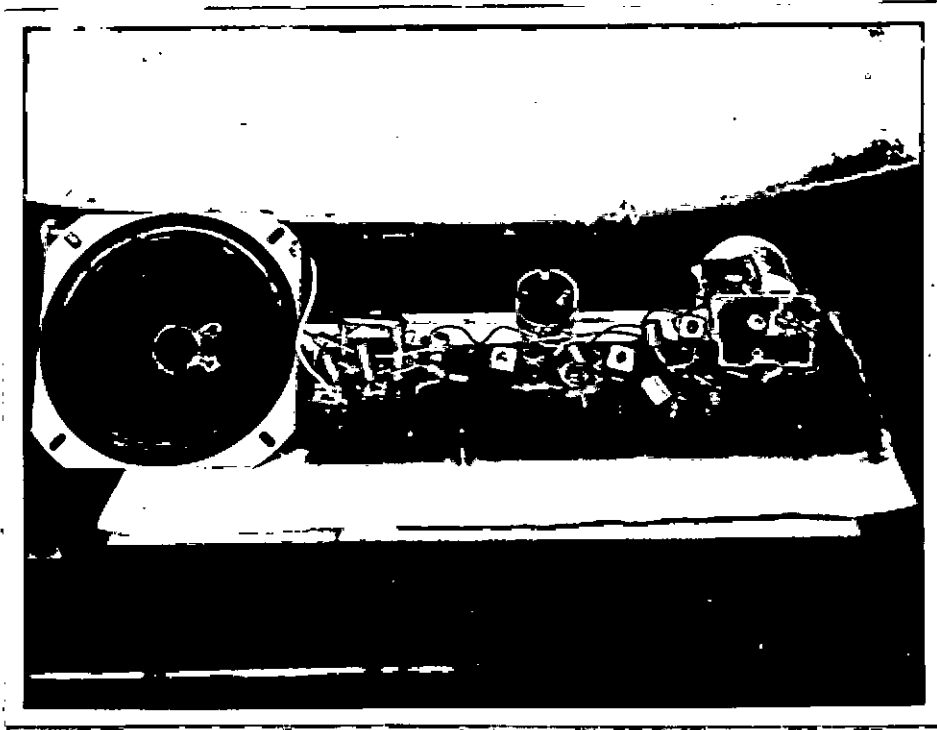

FIG. 2.2 SUPER HETRODYNE RECEIVER

Battery Voltage 6 Volts  
 Intermediate Frequency 455 KC/S  
 Frequency Range 530KHZ - 1620 KHZ  
 Out Put 1Watt  
 Loud Speaker 8Ω





Photograph 2.3  
Superhetrodyne Receiver Set.



Photograph 2.4

Self made a few Radio Components.

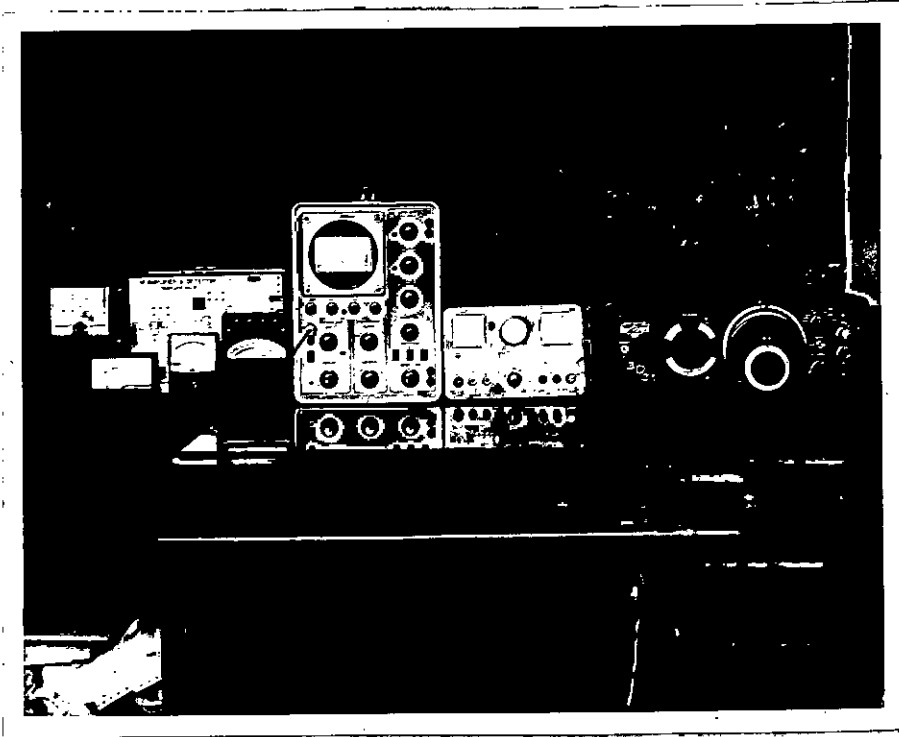

Photograph 2.5

A few Instruments used for Research purpose.

CHAPTER- III

### 3.1 ANTENA COIL

3.1.1 Theory: The design of the receiving aerial is closely associated with the subsequent receiving equipment. It also depends upon the wavelength of the signal. Aerial tuning circuits will contain inductance and capacitance but since, it is operating well below its natural wavelength, additional inductance or capacitance or both will be required to tune it. However, it is more convenient to couple the aerial to a tuned secondary circuit, as shown in Fig. 3.1.

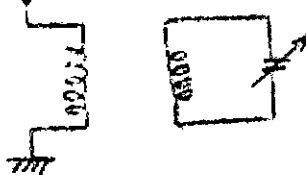

Fig. 3.1 Receiving Aerial Circuit.

Since the aerial is not tuned, a tight coupling is permissible and it is usual to provide a small step up ratio which not only increases the emf developed across the secondary but reduces the effective aerial constant reflected into the secondary and so permits a wider tuning range to be obtained with a given tuning capacitor.

In the equivalent circuit  $X_2 = 0$  since the secondary is tuned, and the equivalent primary resistance is

$$\frac{M^2 W^2}{R} \quad \text{-----} \quad (3.1)$$

Which is, in practice, large compared to the aerial resistance.

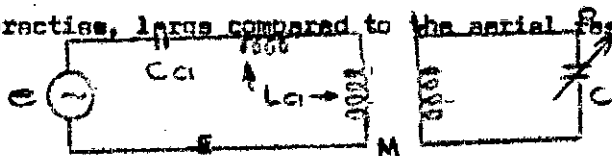

Equivalent circuit of the Aerial

Fig.3.2

$$i_1 = \frac{e}{M^2 W^2 / R + j (W L_B - 1 / W C_B)} \quad \text{-----} \quad (3.2)$$

Where  $L_B$  includes the primary inductance of the transformer, and  $E$ , the voltage across the secondary coil, is given by

$$E = MW \left( \frac{LW}{R} \right) \quad i_1 = \left( \frac{M}{R_C} \right) i_1 \quad \text{-----} \quad (3.3)$$

Since  $W^2 = 1/LC$  ; hence the effective step up

$$\text{is } E/e = \frac{M/R_C}{M^2 W^2 / R + j (W L_B - 1 / W C_B)} = \frac{M/C}{M^2 W^2 + j X_1 R} \quad \text{-----} \quad (3.4)$$

Where  $X_1$  is the reactance of the aerial =  $\omega L_a - 1/\omega C_a$

Maximum output is obtained when

$$M^2 W^2 = X_1 R \dots\dots\dots(3.5)$$

Thus usually gives a step up of the order of 10 to 1 (6)

The use of a step down in this manner will reduce the output voltage, but it must be remembered that the transistor is a current operated device, so that the requirement is for maximum secondary current.

If ferrite aligned approximately in the direction of the receiving <sup>wave,</sup> the magnetic component of the wave is concentrated in the higher permeability material of the rod, and e.m.f is induced in a coil wound round the rod. This coil is designed to have an inductance which, with the appropriate variable capacitor can be tuned over the frequency band required. The output is taken from the secondary winding, the ratio being chosen to provide an effective Q equal to half the unloaded Q i.e.

$$R = L / C P n^2 \dots\dots\dots(3.6)$$

Where R = Secondary resistance

$$\text{and } P = \frac{Q}{2 \pi f c} \dots\dots\dots(3.7)$$

Ferrite rod aerials are directive, producing maximum signal when aligned with the direction of the wave.

3.1.2 DESIGN OF THE ANTENNA COIL: It is required to find out the value of the inductance and the turns of the primary and the secondary wound on the ferrite rod for a medium wave antenna coil, frequency ranges from 530 KHz to 1620 KHz ; selectivity 300-500  $\mu$  v/m .

The value of the variable capacitance is 360 p.f.

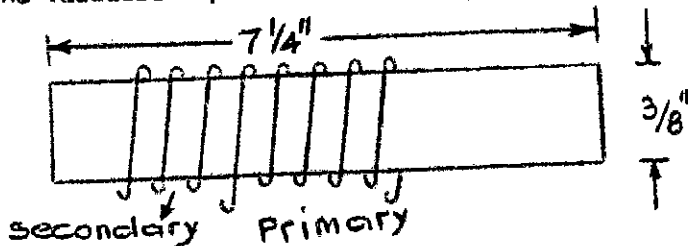

Fig.3.3 A Typical Ferrite Rod.

We know,  $L_s = \frac{25300}{f_{min}^2 C_{max}}$   
 or  $L_s = \frac{1}{W^2 C}$

$L_s = \frac{25300}{530^2 \times 360 \times 10^{-6}} = 256 \mu H$

A typical ferrite would provide an inductance of  $\frac{N^2}{16} \mu H^{(22)} (3.10)$

where N is a number of turns, so that for 256  $\mu H$  the number of turns required is

$\frac{N^2}{16} = 256$  i.e.  $N = 64$  turns.

Q of the coil is  $f/B = \frac{530}{2} = 265$

Resistance of the coil,  $R = \frac{WL}{Q} = 3.22 \Omega$

Secondary turn =  $\frac{64}{10} = 6.4 \approx 6$

$L = 256 \mu H$   $N_1 = 64$

$Q = 265$   $N_2 = 6$

No of S.W.G. used is 38.

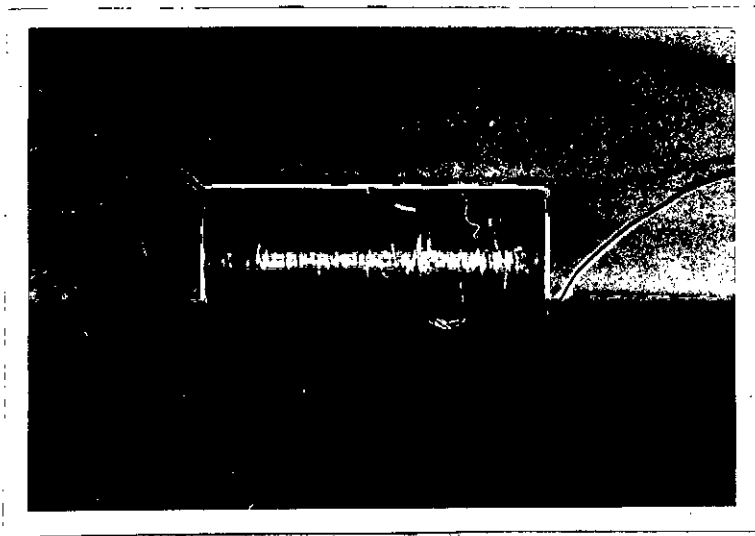

Photograph Rx6 3.1  
Antenna Coil



## 3.2 OSCILLATING COIL

**3.2.1 Theory:** The simplest form of transistor frequency changer uses a self oscillating mixer stage circuit as shown in Fig. 3.4 and the signal is applied to the base, while the collector is coupled back to the emitter through a secondary circuit tuned to the oscillator frequency. The emitter thus carries currents at both signal and oscillator frequencies so that an additive mixing is obtained. The oscillator tuned circuit is designed to cover the frequency band required 530 KHZ - 1620 KHZ and has a high Q, which permits the oscillation to be maintained with only a loose coupling to the transistor, thereby minimizing circuit damping. The coupling windings themselves are so proportioned as to match the collector/ emitter impedance.

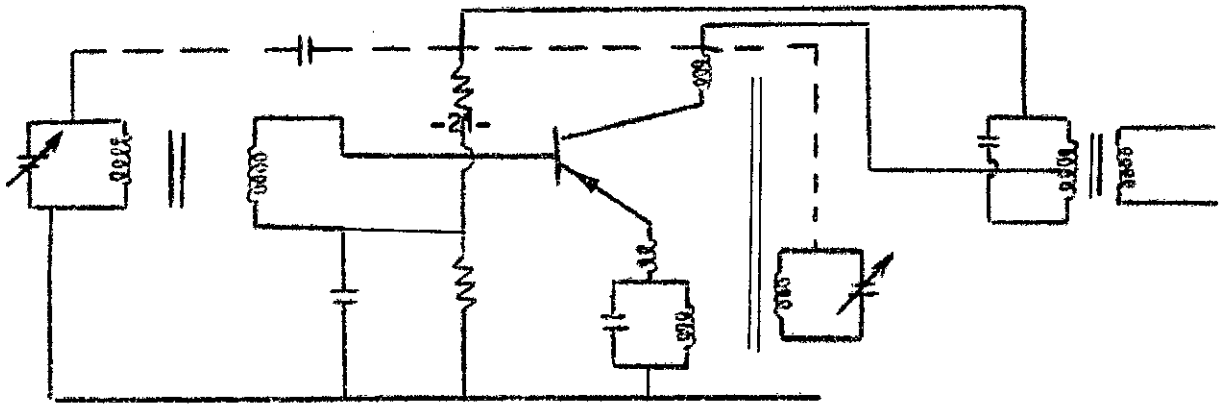

Fig.3.4  
Oscillator Circuit

This circuit is modified using a tapped coil.

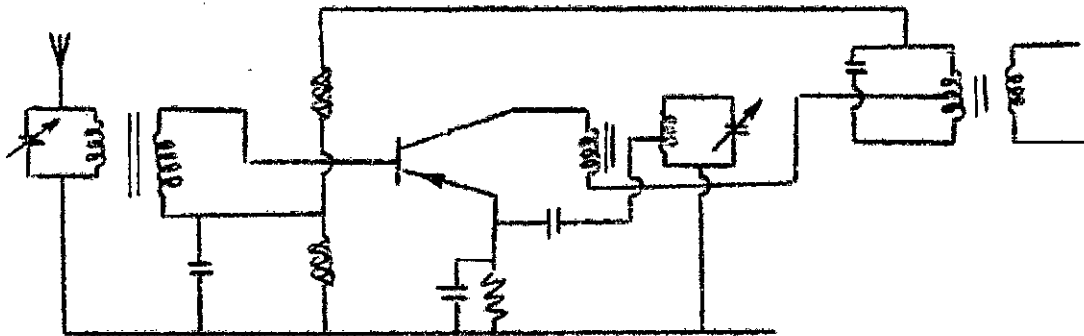

Fig. 3.5 Modified Oscillator Circuit.

Tapped coils are commonly used with oscillator for the reduction of the impedance level from collector to emitter<sup>(5)</sup>. In this application, the unloaded impedance level is selected and the tap is adjusted to reduce the impedance to the desired level. Tapped coils have the advantage that the change of current level is obtained magnetically rather than by way of the circulating current. Consequently, relatively lower Q-factor coils may be used effectively with large values of impedance step down. The step down in a tapped coil functioning as an auto-transformer is approximately proportional to the square of the turns ratio

$$Z_o / Z_i = (n_o/n_i)^2 = n^2 \quad (3.11)$$

This equation applies only if the coefficient of coupling among the various turns of the coil is high and as a consequence, the leakage flux is small.

3.2.2 Choice of Transistor : The main consideration is that of the cut-off frequency of the transistor. Commonly r.f. transistor are used in fixed frequency

oscillator circuits upto 1.25 times the cut off frequency while in variable frequency oscillators the limit is usually about 0.8 times  $f_c$ .

3.2.3 Design Steps :

1. Values of  $C_{padder}$ ,  $C_{trimmer}$  and L are determined.
2. No of turns and the no of wire used in the primary and secondary of the oscillator are calculated.

The oscillator circuit is as shown in fig. 3.6

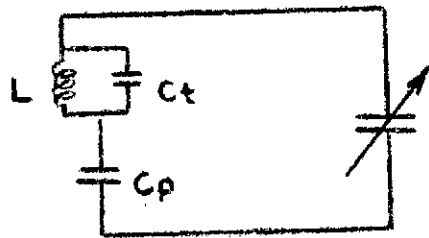

Fig.3.6 Circuits of Trimmer and Padder Capacitance

Zero error can be obtained at three oscillator frequencies  $f_{h1}, f_{h2}$  and  $f_{h3}$  corresponding to signal frequencies  $f_{s1}, f_{s2}$  and  $f_{s3}$ . that for these frequencies C has values  $C_1, C_2$  and  $C_3$  respectively.

$$\text{Then } \frac{1}{(2\pi f_{h1})^2} = L \left[ C_t + \frac{C_p C_1}{C_p + C_1} \right] \quad (3.12)$$

$$\frac{1}{(2\pi f_{h2})^2} = L \left[ C_t + \frac{C_p C_2}{C_p + C_2} \right] \quad (3.13)$$

$$\frac{1}{(2\pi f_{h3})^2} = L \left[ C_t + \frac{C_p C_3}{C_p + C_3} \right] \quad (3.14)$$

From these equations L,  $C_p$ ,  $C_t$  can be found. Hz error/frequency curve is cubic of the form illustrated.

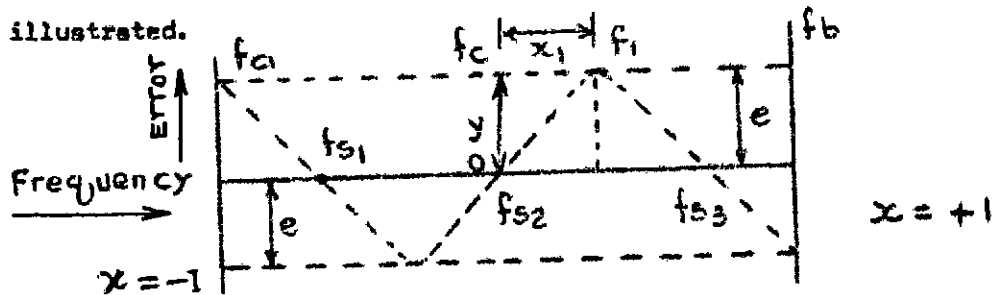

Fig. 3.7 Error /Frequency curve.

The general equation of the curve is

$$Y = ax^3 + bx^2 + cx + d \quad (3.15)$$

Where  $x = 0$   $y = 0$  and when  $x = \pm 1$ ,  $y = \pm e$

$$\text{So the equation reduces to } y = ax^3 + cx \quad (3.16)$$

$$(a+c) = -e \quad (3.17)$$

and At frequency  $f_1$  where  $x = x_1$

$$\frac{dy}{dx} = 0$$

$$x_1 = \pm \sqrt{-c/3a} \quad (3.18)$$

Since  $y = e$  at  $x = x_1$  From equation (3.16, 3.17, 3.18) (3.19)

From 20 and 23 equations,  $c = -3a/4$

$$\text{Again, } y = ax(x^2 - 3/4) \quad (3.20)$$

$$\text{For zero error } x = 0 \quad \text{or} \quad \pm \sqrt{3/4}$$

$$\text{i.e. } f_{e2} = f_c, \quad f_{e1} = f_c - \frac{\sqrt{3}}{\sqrt{4}} (f_c - f_a)$$

$$f_{e3} = f_c + \frac{\sqrt{3}}{\sqrt{4}} (f_b - f_c)$$

$$\text{In this case, } f_a = 530 \text{ kc/s}$$

$$f_b = 1620 \text{ KC/s}$$

$$f_c = 985 \text{ KC/s}$$

$$\text{So } f_{e1} = 985 - \frac{\sqrt{3}}{\sqrt{4}} (985 - 530) = 895 \text{ KC/s}$$

$$f_{e2} = 985 \text{ KC/s and } f_{e3} = 1525 \text{ KC/s}$$

$$\text{Calculated value of } C_1 = 270 \text{ pf}$$

$$C_2 = 163 \text{ pf}$$

$$C_3 = 25 \text{ pf}$$

Assuming 40pf is due to stray capacitance of the oscillator tuning circuit.  
 40 pf is due to stray capacitance ( wiring , self capacitance )

$$f_{h1} = ( f_{s1} + 455 ) = 1050 \text{ KC/s}$$

$$f_{h2} = ( f_{s2} + 455 ) = 1440 \text{ KC/s}$$

$$f_{h3} = ( f_{s3} + 455 ) = 1980 \text{ Ko /s}$$

Solving Equations (3.12, 3.13, 3.14)

$$C_p = 85 \text{ pf} \quad C_t = 195 \text{ pf} \quad \text{and } L = 88 \text{ } \mu\text{h.}$$

Transformer Design :

wire used 44 S W G.

With a typical core 1/8" dia an inductance of 88  $\mu\text{H}$  would be obtained applying theory

$$\frac{N^2}{30} = 88 \text{ } \mu\text{H} \quad (19)$$

Where N is the no of turns

$$N = \sqrt{30 \times 88} = 66 \text{ turns.}$$

Applying Equation 3.11.

$$\text{The ratio of windings} = n = \sqrt{\frac{30}{1}} = 5.5$$

Assuming ,  $Z_o = 30 \text{ k}\Omega$  and  $z_i = 1 \text{ k}\Omega$  for an oscillating transistor.

$$\text{The secondary winding turns} = \frac{66}{5.5} = 12$$

$$\text{Again, } \frac{Z_o}{Z_i} = 30$$

Primary windings will be tapped at

$$\frac{66}{30} = 2.2 \approx 2$$

That is ( 64 + 2 ) turns in the primary.

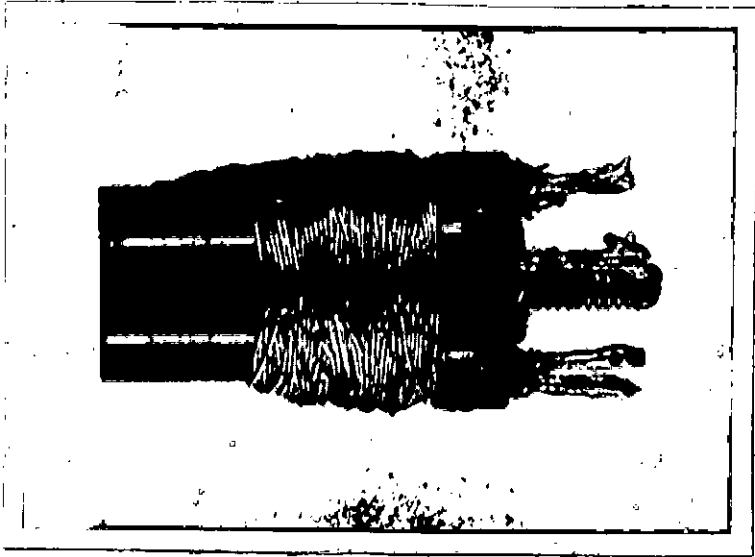

Photograph 3.2  
Oscillating  $\theta$  Coil

### 3.3 INTERMEDIATE FREQUENCY TRANSFORMER

3.3.1 Theory : Communication transformers, even in their simplest form, consist of a network of inductances and capacitances and therefore can function as wave filters. The transformer networks are in the form of a band-pass filter. The double tuned transformer serves as a filter and is, therefore, a very useful device. It combines filtering action and the usual isolation and sets up features of a transformer in a single unit of simple construction.

Double tuned transformers derive their name from the variable adjusting capacitors originally used to tune the primary and secondary windings. Such transformers are usually used to transmit a narrow band of frequencies for example 450 to 460 Kc and to attenuate all other frequencies as much as possible. They find their principal applications in I.F. amplifiers. There the resonance of the windings with the capacitances provides high impedance and high gain between stages in addition to attenuating the unwanted frequencies.

The narrow-band transmission requires a large series impedance in the equivalent network that is easily obtainable by loosely coupled primary and secondary windings. High attenuation requires high Q's readily obtainable with either self supporting air core coils or coils with ferrites core inserted in them. The core may be used for tuning purposes. The resulting construction consisting of two self-supporting windings side by side is simple and inexpensive. Selectivity is obtained by the use of parallel L-C circuit which resonates at the desired frequency :

In the I.F.T. method of coupling is considered. Inductively coupled circuit can be represented by the equivalent circuit of the fig 3.8 in which  $Z_1$  is the primary impedance,  $Z_2$  is the secondary impedance and  $M = K \sqrt{L_1 L_2}$  is the mutual inductance that exists between them.

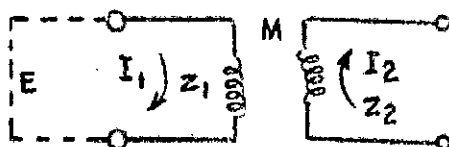

Fig. 3.8.

Equivalent Network of Inductively Coupled Circuit.

The performance of the circuit may be examined as follows :-

$$\begin{aligned} \text{Impedance coupled from secondary into primary} & \quad (3-21) \\ & = (WM)^2 / Z_2 \end{aligned}$$

$$\text{Equivalent primary impedance} = Z_1 + (WM)^2 / Z_2 \quad (3-22)$$

$$\text{Primary current } I_1 = \frac{V}{Z_1 + (WM)^2 / Z_2} \quad (2.23)$$

$$\text{Voltage induced in secondary} = -jWM I_1 \quad (3.24)$$

$$\begin{aligned} \text{Secondary current. } I_2 & = \frac{-jWM I_1}{Z_2} \\ & = \frac{-jWMV}{Z_1 Z_2 + (WM)^2} \end{aligned} \quad (3.25)$$

When the mutual inductance is small and the secondary impedance is large, the coupled impedance is small. Under these conditions the primary current is almost the same as if no secondary were present. If however  $Z_2$  is small and  $M$  is not small, then the coupled impedance is significant. When  $Z_2$  is reactive with a given phase angle, the coupled impedance has the same phase angle but with the sign reversed. When  $Z_2$  is purely resistive the coupled impedance is also resistive.

### 3.3.2 Design Steps : (4)

1. Under what d.c. condition the transistor is to be operated is decided. The values of emitter and base resistors and bypass capacitor are calculated.
2. A hybrid II equivalent circuit is drawn and the value of  $R_{out}$  and  $R_{in}$  is calculated and thus the turns ratio of the IFT is determined.
3.  $R_n$  and  $C_n$  for the neutralizing circuit is calculated.
4. Equivalent impedance which represents the standing effect of the neutralizing components across the input and output is calculated and the final equivalent circuit is constructed.
5. With the knowledge of bandwidth required for the each stage the tuned circuit effective  $Q$  is determined.



6. Assuming a value for the unloaded Q, the tuned circuit capacitor C is selected, L is calculated to resonate with C at the centre frequency, and the values of r and L/C<sub>r</sub> are determined.

7. The required sheeting resistance across the tuned circuit to provide the correct bandwidth is calculated and thus what resistance should be reflected from the transistor output to achieve it is established.

8. Knowing this value, at what pt the transformer primary should be tapped is calculated.

Transistor NO OC 45 (18)

f<sub>c</sub> = 6 MC /S when operated at Collector voltage of

VCE = 6 V and IC = 1 mA.

r<sub>b'b</sub> = 75 Ω

C<sub>b'e</sub> = 1000 pf

r<sub>b'e</sub> = 1.3 kΩ

C<sub>b'c</sub> = 10.5 pf

r<sub>b'c</sub> = 33 MΩ

gm = 38 mA/V

Setting up the D.C. Condition (19)

Let R<sub>E</sub> = 820 Ω so that VE = .82 V

For V<sub>c</sub> = 6 V and allowing for VE and the voltage drop across the tuned circuit V<sub>cc</sub> = -7V.

Thus making V<sub>B</sub> = -IV.

7 R<sub>2</sub>/R<sub>1</sub> + R<sub>2</sub> = 1 and 6 R<sub>2</sub> = R<sub>1</sub>

Also making  $\frac{R_1 R_2}{R_1 + R_2} = 10 R_E = 8.2 \text{ k}\Omega$

Therefore, R<sub>1</sub> R<sub>2</sub> = 8.2 R<sub>2</sub>

6 R<sub>2</sub> = 57.4 kΩ

Let R<sub>2</sub> be 10 kΩ and hence R<sub>1</sub> should be 56 kΩ

Suitable decoupling capacitances are CE = .25 μf and C<sub>1</sub> = .1 μf

Input and output impedances : (7)

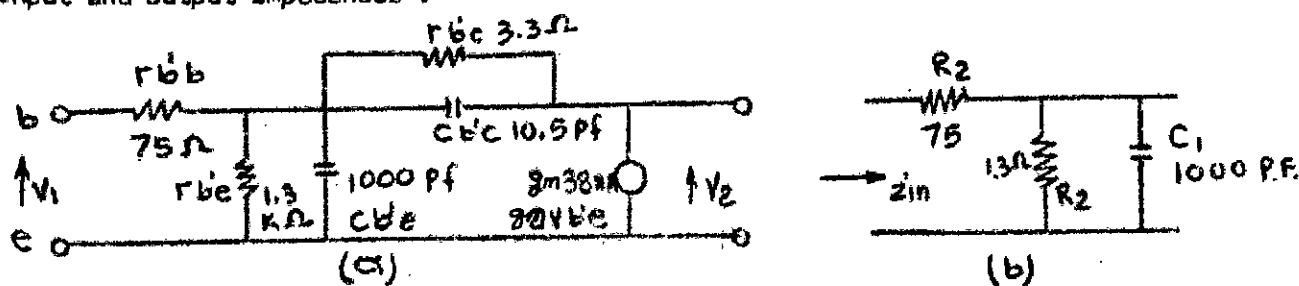

Fig. 3.9 (a) Equivalent circuit of BC45

Fig. (b) is drawn as the effective input circuit of  $V_2$  is short ckted and if  $C_{b'c}$  and  $r_{b'c}$  are ignored.

$$Z(R_1, C_1) = \frac{jR_1 X_1}{R_1 + jX_1} = \frac{R_1 X_1^2}{R_1^2 + X_1^2} + \frac{jR_1^2 X_1}{R_1^2 + X_1^2}$$

Substituting values this becomes a resistance of 78  $\Omega$  in series with a capacitance reactance of 310  $\Omega$ . Adding  $r'_{bb}$  = 75  $\Omega$

$$R_s = 153 \Omega \text{ and } X_s = 310 \Omega$$

This is now converted into an equivalent parallel circuit of  $R_p$  and  $C_p$

$$\text{Admittance } Y = G + jB = \frac{R_s}{R_s^2 + X_s^2} + \frac{jX_s}{R_s^2 + X_s^2} \quad (3.27)$$

$$\text{Therefore, } R = \frac{R_s^2 + X_s^2}{R_s} \text{ and } X_p = \frac{R_s^2 + X_s^2}{X_s}$$

$$\text{From which } R_p = R_{in} = 780 \Omega \text{ and } X_p = 386 \Omega$$

So  $C_p = C_{in} = 875 \text{ p.f.}$  By short ckting  $V_2$ , the output circuit becomes

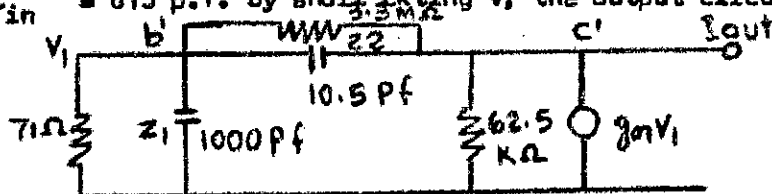

Fig. 3.10 Equivalent Network of the output Circuit with  $V_2$  short circuited.

Making use of nodal analysis at node  $b'$ .

$$\frac{V_1}{Z_1} + \frac{V_1 - V_0}{Z_2} = 0$$

at node C<sup>1</sup>

$$\frac{V_o}{23} + \frac{V_o - V_1'}{Z_2} + g_m V_1 = Z_o \quad (3.29)$$

$$V_1' = Z_1 V_o / (Z_1 + Z_2) \quad (3.30)$$

$$V_o \left[ \frac{1}{Z_3} + \frac{1}{Z_2} + \left( \frac{Z_1}{Z_1 + Z_2} \right) \left( g_m - \frac{1}{Z_2} \right) \right] = I_o$$

Therefore output impedance

$$Z_o = \frac{V_o}{I_o} = \frac{1}{\left( \frac{1}{Z_3} \right) \left( \frac{1}{Z_2} \right) + \left[ Z_1 \quad (Z_1 + Z_2) \right] \left[ \frac{g_m - \left( \frac{1}{Z_2} \right)}{Z_1 + Z_2} \right]} \quad (3.31)$$

Calculating component parts of this expression separately yields,

$$Z_1 = (6709 - j 14.28) ; (14 + j 2.96) 10^{-3}$$

$$Z_2 = (.31 - j 31.8) 10^3 ; \frac{1}{Z_2} = (.3 + j 31) 10^{-6}$$

$$Z_3 = 62.5 \times 10^3 ; \frac{1}{Z_3} = 16 \times 10^{-6}$$

$$\text{Thus } \frac{1}{Z_3} + \frac{1}{Z_2} = (16.3 + j 31) 10^{-6}$$

$$Z_1 / (Z_1 + Z_2) = (.474 + j 2.128) 10^{-3}$$

$$g_m - \frac{1}{Z_2} = (38000 - j 31) \times 10^{-6}$$

Substituting these values in Equation (3.31)

$$Z_o = \frac{(34.4 - j 111.9) 10^6}{13705}$$

Resistance  $R_s = 2.51 \text{ k}\Omega$  in series with reactance

$$X_s = 8.16 \text{ k}\Omega$$

Resolving into equivalent parallel components

$$R_{out} = \frac{R^2 + X^2}{R} = 29 \text{ k}\Omega$$

$$X_p = \frac{R^2 + X^2}{X} = 8.16 \text{ k}\Omega$$

$$C_{out} = 38 \text{ pf.}$$

$$\text{Transformer ratio } n = \frac{29000}{780} = 6$$

For optimum output  $R_2 =$  reflected impedance of the input impedance  $n^2 R_{in}$ .

Neutralizing circuit :

$$R_n = A_z b b' \left( \frac{1 + c b' c}{c b' c} \right) = 75/6 \left( 1 + \frac{1000}{10.5} \right) = 1.188 \text{ k}\Omega$$

$$C_n = \frac{C b' c}{A} = 6 \times 10.5 = 63 \text{ pf.}$$

Preferred values of  $R_n = 1.2 \text{ k}\Omega$  and  $C_n = 68 \text{ p.f.}$

Shunting effect on input at 455 Kc/s the reactance of 68 pf = 5 K $\Omega$

$$R_{pi} = \frac{R_n^2 + X_n^2}{R_n} = \frac{(1.44 + 25) \times 10^6}{1.2 \times 10^3} = 22 \text{ K}\Omega$$

$$X_{pi} = \frac{R^2 + X^2}{X} = \frac{26.44 \times 10^6}{5 \times \frac{1000}{10^3}} = 5.28 \text{ k}\Omega$$

$$\text{Thus } C_{pi} = 64 \text{ p.f.}$$

Shunting effect on output

$$R_{po} = n^2 R_{pi} = 792 \text{ k}\Omega$$

$$C_{po} = C_{pi} / n^2 = 1.8 \text{ p.f.}$$

Assuming the stage is followed by a similar stage having the same input impedance, the final equivalent circuit is that of fig. 3.11. In this the conductance of the representative current generator has been given a value of 35 instead of 38 m A/V. This is necessary because the current is now shown as a function of  $V_{in}$  at the base connection

and not of  $r_{b'e}$ . The difference in gm takes account of voltage lost in  $r_{bb'}$ .

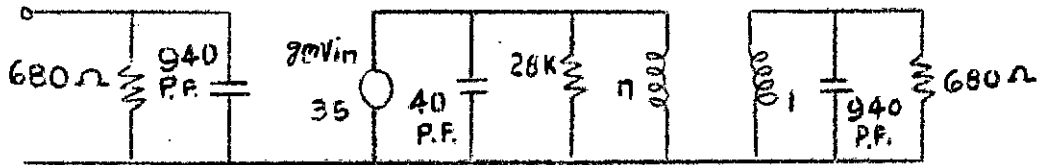

Fig. 3.11 Equivalent circuit of transistorised IF Transformer.

The capacitance reflected from the secondary into the primary is  $940/n^2$  = 26 pf, giving a total primary capacitance of 66 p.f.

Similarly the resistance reflected from the secondary into primary is  $680 n^2$  = 24.5 k  $\Omega$  giving a total shunt resistance of about 13 k  $\Omega$ . To reduce the loading effect of this resistance on the tuned circuit a tapped primary winding is used.

It is necessary to assume a value for equivalent resistance  $R_D = L/CR$ .

There is no optimum here, since the higher the value of equivalent resistance, the less will be the coil loss. In practice it is customary to take  $R_D = R_1 R_2 / (R_1 + R_2)$

=  $\frac{1}{2} R_{out}$  which makes  $Q_{working} = \frac{1}{2} Q_0$  and  $Z_w = 1/4 R_{out} = 7.25 k\Omega$ . If we assume a bandwidth of 9 KC/s at a frequency of 455 Kc/s

$Q_w = \frac{f}{B} = 50.5$  while the inductance of the tuned circuit =  $8Z_w / 2 \pi f^2$ .  
becomes  $L = 9 \times 10^3 \times 7.25 \times 10^3 / (2 \pi \times 20.7 \times 10^6) \approx 52 \mu H$

The capacitance  $C = \frac{1}{L \omega^2} = 2410$  pf which is too high, a figure of 240 pf being more practicable. The output capacitance of 1st oscillating transistor would be about 40 pf while the reflected capacitance of IF transistor input would be about 25 pf. These two stages will thus contribute 65 pf. to the total leaving 2345 pf to be supplied as the reflected capacitance of 240 pf across the full primary. Hence the tap ratio is

$$\sqrt{\frac{2345}{240}} = 3.1 \text{ and the total inductance is } 52 \times 3.1^2 \approx 500 \mu H.$$

These windings will be housed in a ferrite core assembly. A typical core  $1/8''$  dia  $1 - \frac{1''}{16}$  length would provide an inductance of

$$\frac{N^2}{50} \mu (19) \text{ where } N \text{ is a no of turns (wire used is 44 SWG), so}$$

that for 500 the no of turns required is 158. These wire used must be such that the resistance of the coil at 455 Kc/s is 6.3 to provide  $Q_0 = 101$ . The coil would be tapped at  $\frac{158}{3.1} = 50$  turns while the secondary winding would be  $\frac{158}{5.5} = 28$

So primary winding = 150 turns, 100 and 50

Secondary winding = 28 turns.

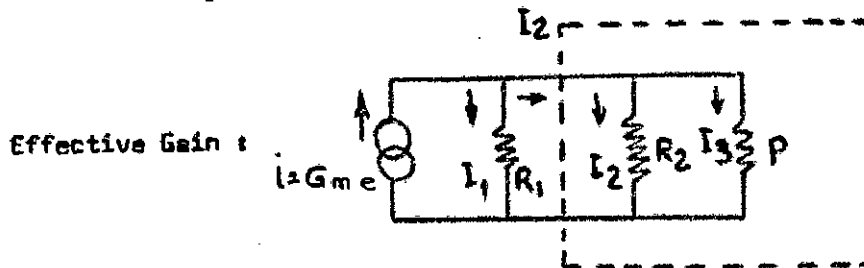

Current generated in the transistor  $R_L$  devices between the internal and external loads  $R_1$  and  $R_L$  shown in fig.

$$\begin{aligned} \text{The proportion in the } R_L \text{ is } I_L &= \frac{i R_1}{R_1 + R_L} \\ &= G_m e \frac{R_1}{R_1 + R_L} \end{aligned} \quad (3.32)$$

and the external power is thus

$$i_L^2 R_L = G_m^2 e^2 R_L \left( \frac{R_1}{R_1 + R_L} \right)^2 \quad (3.33)$$

The load  $R_L$  however is composed of  $R_2$  in parallel with the tuned circuit impedance  $p$ , so that the current will divide further, and proportion of the total external power which is actually developed in  $R_2$  is  $P / (P + R)$

Hence the power  $R_2$  is

$$W_2 = G_m^2 e^2 R_L \left( \frac{R_1}{R_1 + R_2} \right)^2 \left( \frac{P}{P + R} \right) \quad (3.34)$$

The input power is  $c^2 / R_{in}$  so that power gain

$$A_p = G_m R_L R_{in} \left( \frac{R_1}{R_1 + R_2} \right) \left( \frac{P}{P + R} \right) \quad (3.35)$$

If  $P = \infty$  and  $R_L = R_1$ , which is the condition for maximum output, this reduces to

$$(A_p)_{max} = 1/4 G_m^2 R_L R_{in} \quad (3.36)$$

A typical value for  $G_m$  is  $35 \mu A/V$ , so that if  $R_L = 29 \text{ k}\Omega$  and

$$R_{in} = .78 \text{ k}\Omega$$

$$\begin{aligned} (A_p)_{max} &= \frac{1}{4} 35^2 \times 10^{-6} \times 29 \times 10^3 \times 780 \\ &= 7000 \quad = 20 \log 7000 \text{ db} = 38. \text{db.} \end{aligned}$$

If now  $p = 14.5 \text{ k}\Omega$   $R_L$  becomes  $\frac{29 \times 14.5}{43.5} = 9.7 \text{ k}\Omega$

and the power gain becomes

$$\begin{aligned} A_p &= 35^2 \times 10^{-6} \times 9.7 \times 10^3 \times 780 \left( \frac{29}{36.4} \right)^2 \times \frac{14.5}{43.5} \\ &= 1760 \quad = 20 \log 1760 \text{ db} = 32.2 \text{ db} \end{aligned}$$

$$W_{actual}/W_{max} = \left( \frac{Q_o - Q_w}{Q_o} \right)^2 = \frac{(101 - 50.5)^2}{101^2} = \frac{1}{4}$$

Coil loss is so long  $\left( \frac{Q_o}{Q_o - Q_w} \right) \text{ db} = 20 \log 2 = 6 \text{ db.}$

Voltage Gain : The voltage gain of the stage is the square root of the power gain.

Expressed in db  $A_v = \frac{1}{2} A_p.$

The voltage developed across the tap portion of the primary is  $G_m Z$  where  $Z$  is the effective collector impedance  $7.25 \text{ k}\Omega$ . The voltage at the secondary is  $\frac{1}{n}$  of this,

$$\begin{aligned} \text{so that } A_v &= G_m Z/n = 35 \times 10^{-3} \times \frac{7.25 \times 10^3}{5.5} \\ &= 42.0 \quad = 16. \text{ dB.} \end{aligned}$$

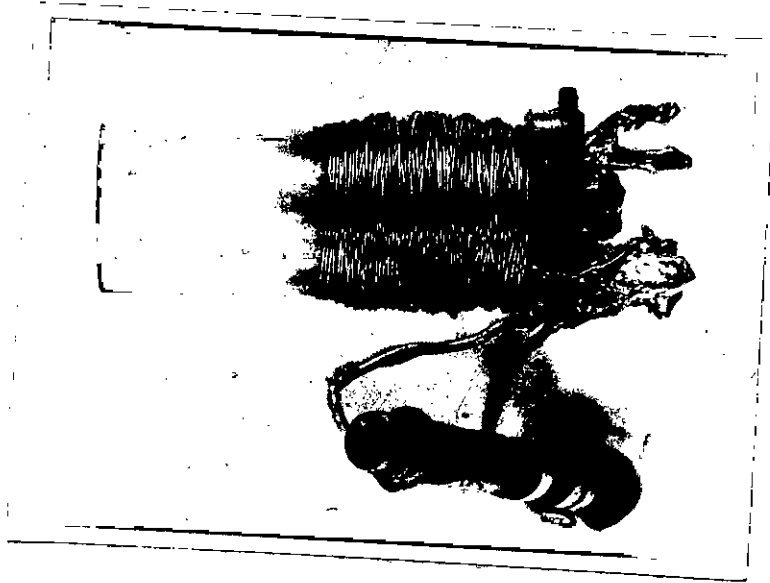

Photograph 3.3  
I.F. Transformer



### 3.4 INPUT OUTPUT TRANSFORMER

3.4.1 Theory of Pushpull stages : Pushpull operation is obtained from a pair of transistors by applying to the base of one transistor a voltage in phase opposition to that applied to the other. The collectors of these transistors are joined to opposite ends of the primary of a transformer, the centre tap of which is connected to the -ve terminal of the batteries. The D.C. collector currents produce opposing voltages in the transformer primary, but the a.c. output currents, owing to the  $180^\circ$  phase shift between the base voltages, are additive.

Pushpull operation has three important advantages :-

1. Even harmonic distortion produced in each output transistor is partially (completely) if matched transistors are employed) cancelled.
2. The d.c. current component in the output transformer is reduced considerably or cancelled. This means less attenuation (frequency) and non-linear (harmonic) distortion, and more efficient operation of the output transformer. A much smaller air gap is required so that primary inductance, for a given number of turns, is greater than for the single transistor output transformer.
3. Hum voltages in the emitter or base bias circuits, if common to both transistors are cancelled.

Disadvantage: Class B push-pull amplifier should have its two transistors biased to cut off, but in practice, this causes cross over distortion if the change over in current from one transistor to the other is not smooth. This type of distortion may be largely overcome by supplying the drive for the stage from a high resistance source and by applying a small forward bias to each transistor. The bias would typically be 100-200  $\mu\text{V}$  giving rise to a quiescent current of a few milli amps. In the basic circuit the bias is provided by  $R_1$  and  $R_2$ .

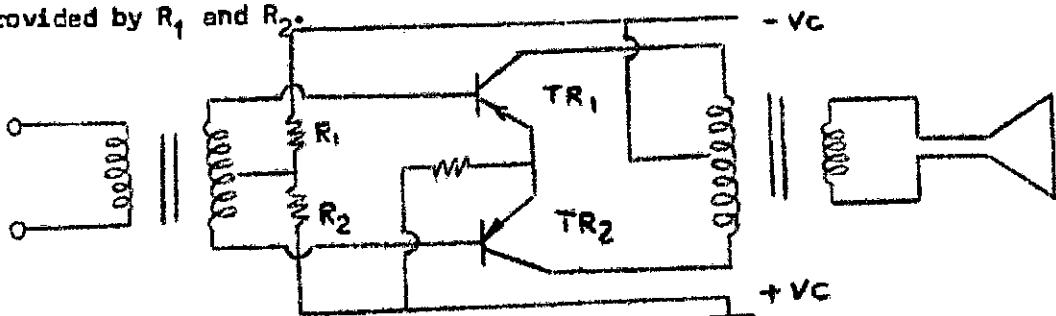

Fig. 3.12 Pushpull stage with input output Transformer.

The value of  $V_{BE}$  required at a transistor for any given collector current falls as the temperature rises, a decrease of  $2.5 \text{ mV}/^\circ\text{C}$  being typical. The temperature range over which the stage is to be used should therefore be considered since, with an increase in temperature,  $V_{BE}$  rises and may reach such a magnitude that in spite of the fixed bias provided, cross over distortion is again present. Similarly, a large reduction in ambient temperature may so reduce the quiescent current that it becomes insufficient to reduce their distortion.

Such effects of temperature changes may be minimized by shunting  $R_2$  with a negative temperature coefficient thermistor. Thus, as temperature rises, the resistance of the parallel combination falls and the base voltage  $V_{BEE}$  is decreased, offsetting the rise in collector current. A resistor in the emitter circuit  $R_E$  similarly increases stability but at the expense of efficiency it usually of a low value.

A quantitative study can begin with some specific statements about the load into which each transistor works. Let  $R_L'$  be defined as the impedance between an end and the tap on the output transformer. The quantity  $R_L$  is the load seen by either transistor. If turns, we can define.

$$R_{c.c} = n^2 R_L \quad (3.37)$$

$$R_L' = \left(\frac{n}{2}\right)^2 R_L = \frac{n^2 R_L}{4} \quad (3.38)$$

$R_{cc}$  = Total impedance end to end at the primary.

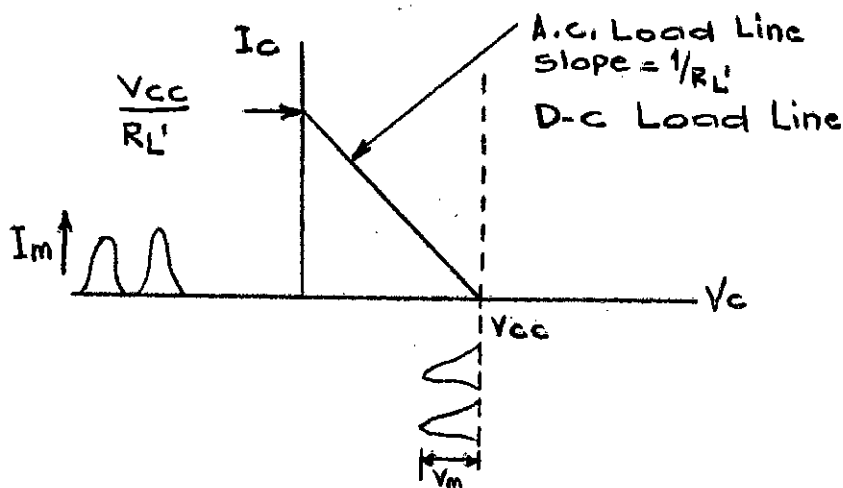

Fig. 3.13 Single Characteristics Analysis for Class B Pushpull Performance.

For the half-sinusoide of current and voltage the relation between  $r_{ms}$  and peak values is

$$V = \frac{V_m}{2} \quad (3.39)$$

$$I = I_m/2 \quad (3.40)$$

$$I_m = \frac{V_m}{R_L'} \quad (3.41)$$

$$\text{Ideal } P_{rms} = VI = \frac{V_m}{2} \cdot \frac{I_m}{2} = \frac{V_m}{2} \cdot \frac{1}{2} \cdot \frac{V_m}{R_L'} = \frac{V_m^2}{4R_L'} \quad (3.42)$$

The output of the pair transistors requires on a summation of this equation two times thus ideal  $P_{rms} = \frac{V_m^2}{2R_L'} = \frac{2V_m^2}{R_{cc}}$  (3.43)

Maximum ideal value of  $V_m$  is  $V_{cc}$ .

Now for the half sinusoidal waveform.

$$\text{Ideal } I_{AVG} = I_m/\pi = \frac{V_m}{\pi R_L'} \quad (3.44)$$

The battery power required for one transistor is

$$\text{ideal } P_{bat} = V_{cc} \frac{V_m}{\pi R_L'} \quad (3.45)$$

For two transistors,

$$\text{Ideal } P_{bat} = \frac{2 V_{cc} V_m}{\pi R_L'} \quad (3.46)$$

The maximum battery power is required when  $V_m$  is its maximum value of  $V_{cc}$ . Thus for one transistor  $\text{max ideal } P_{bat} = \frac{V_{cc}^2}{\pi R_L'}$  (3.47)

For two transistors

$$\text{Max. ideal } P_{bat} = \frac{2 V_{cc}^2}{\pi R_L'} \quad (3.48)$$

$$= \frac{8 V_{cc}^2}{\pi R_{cc}} \quad (3.49)$$

$$\text{Efficiency (ideal)} = \frac{P_{rms}}{P_{bat}} = \frac{\pi V_m}{4 V_{cc}} \quad (3.50)$$

Assuming ideal transistors, the load presented to each transistor is  $R_o = \frac{V_{cc}^2}{2 P_o (\text{max})}$  (3.51)

However, in using this equation, a voltage some what less than  $V_{CC}$  should be considered allowing say .5 V to avoid distortion as the bottoming voltage is approached. Similarly the value for  $P_o$  max should be higher than that required since the load on the transistor includes the unbypassed resistor  $R_E$  and some power is lost in the resistor. The useful power output is given by

$$P_{eff} = P_o \max \frac{R_C}{R_C + R_E} \quad (3.52)$$

### 3.4.2 Design steps :

1. Suitable pair matched transistors are selected and the load to be presented to each collector is evaluated and the ratio of the output transformer is determined.

2. Suitable values for  $R_1$ ,  $R_2$  and  $R_E$  are selected and whether the output power to the output transformer by the value of  $R_E$  is sufficient or not is checked.

DESIGN: Load Speaker has 8  $\Omega$  voice coil. The allowable attenuation at 50 c.p.s. and at 10, 000 c.p.s. is 0.5 db. The ferro-magnetic distortion at 50 c.p.s should not exceed 3% Transistors No 25B156 (20)

$V_C$	$V_E$	$I_C$	$I_E$	$P_C$	$T_j$	$V_C$
Bo	Bo	mA	mA	mW		Dc
	V					Vc
-16	-2.5	-300	300	150	85	-1

Collector to emitter voltage.

Emitter current in mA	Rating	IC80 A	$V_{CB}$ V	$I_{EB0}$
150	70	-14	-12	-12

Dc supply voltage V	Zero signal DC collector current mA	Peak collector current mA	Load impedance collector to collector
6	-2.5 / transistor	245/ transistor	86

Power gain	Max distortion	Emitter resistance
27 db	7%	2

$T_a = 25^\circ C$  1W undistorted signal power output.

Collector load :- Let  $V_{CC}$  be reduced by .5 V.

$$R_C = \frac{86}{4} = 22 \Omega$$

Total load on each transistor

$$R_C + R_E = 22 + 2 = 24 \Omega$$

$$\text{Total power } P_o \text{ (max)} = \frac{V_{cc}^2}{2(R_C + R_E)} = \frac{5.5^2}{44} = 686 \text{ mW}$$

$$\text{Useful power output} = P_o \text{ max} \times \frac{R_C}{R_C + R_E} = 686 \times \frac{22}{24} = 630 \text{ m.W.}$$

$$\text{Now } R_1 + R_2 = \frac{V_{cc}}{I_{CQ}} = \frac{6 \text{ V}}{2.5 \text{ mA}} = 2.4 \text{ K}\Omega$$

Zero signal d.c. collector current per transistor

$$\text{Let } R_1 = 2.2 \text{ K}\Omega \quad R_2 = 200 \Omega$$

For increased stability  $R_2$  may be changed, to 300  $\Omega$  shunted by a N.T.C. thermistor having a nominal resistance of 200  $\Omega$ .

The required transformer turns ratio for use with a speaker having a nominal impedance of 8 is

$$\frac{N_1}{N_2} = \sqrt{\frac{86}{8}} = 3$$

As the transformer is centre tapped, so the ratio becomes (1.5 + 1.5) : 1

The effective series resistance

$$R_k = \frac{44 \times 86}{130} = 29 \Omega$$

$$\frac{R_k}{2p} = .15$$

2 p

$$2p = \frac{29}{.15} = 194 \Omega$$

From the graph 1

Assuming permeability angle  $20^\circ$

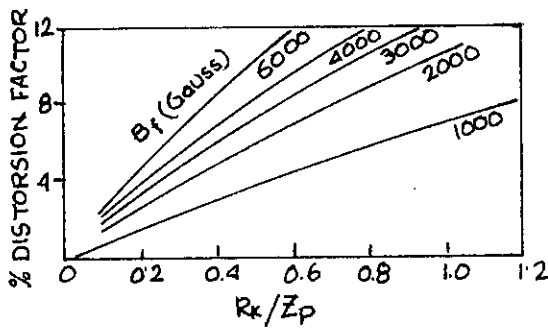
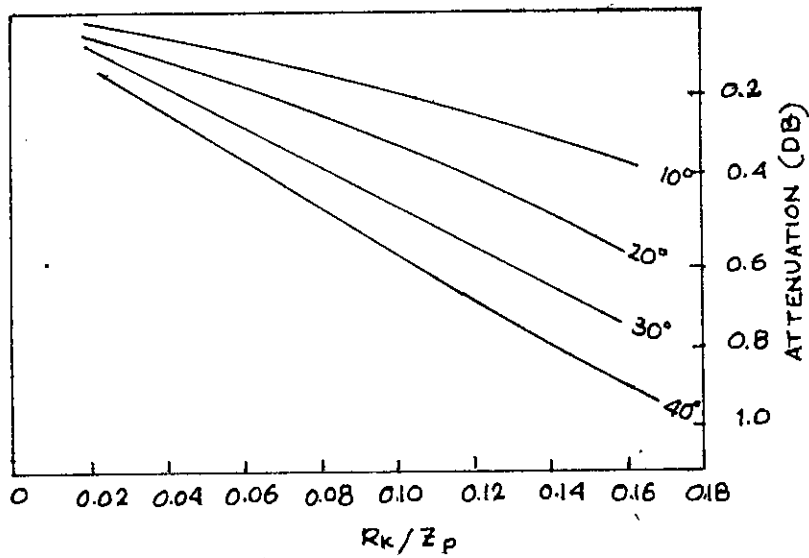

Fig. 3.14

Distortion factor for Stulloy at 50 cps.  $B_p$  is the peak value of the fundamental component of flux density (Gross 88%).

Figures supplied by Messrs G.K.N.

Group Services Ltd.

To decide the maximum allowable flux-density the ratio  $BK/2P$  is referred to fig. 3.14. The result is  $B = 4500$  gauss for 3% ferromagnetic distortion.

The cross sectional area of the core chosen is  $.25$  sq. cm.

No of primary turns is seen to be

$$N_p = \frac{10^8 \sqrt{22 L P}}{A B W_1} \quad (3)$$

$$= \frac{10^8 \sqrt{2 \times 86 \times 630 \times 10^{-3}}}{.25 \times 4500 \times 2 \times 400 \times \pi} = 368 \text{ turns.}$$

i.e. ( 184 + 184 ) turns.

$$N_s = \frac{368}{3} = 122 \text{ turns.}$$

Wires used in the Primary and secondary are

38 SWG & 28 SWG respectively.

For input transformer.

$$\text{Turns ratio } \frac{N_1}{N_2} = \frac{2500}{4 \times 50} = 1.6$$

Output impedance of the driving stage is  $2.500 \text{ K}\Omega$

input impedance of the transformer is  $50 \Omega$

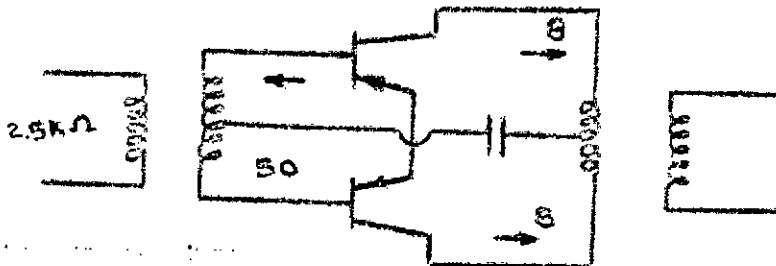
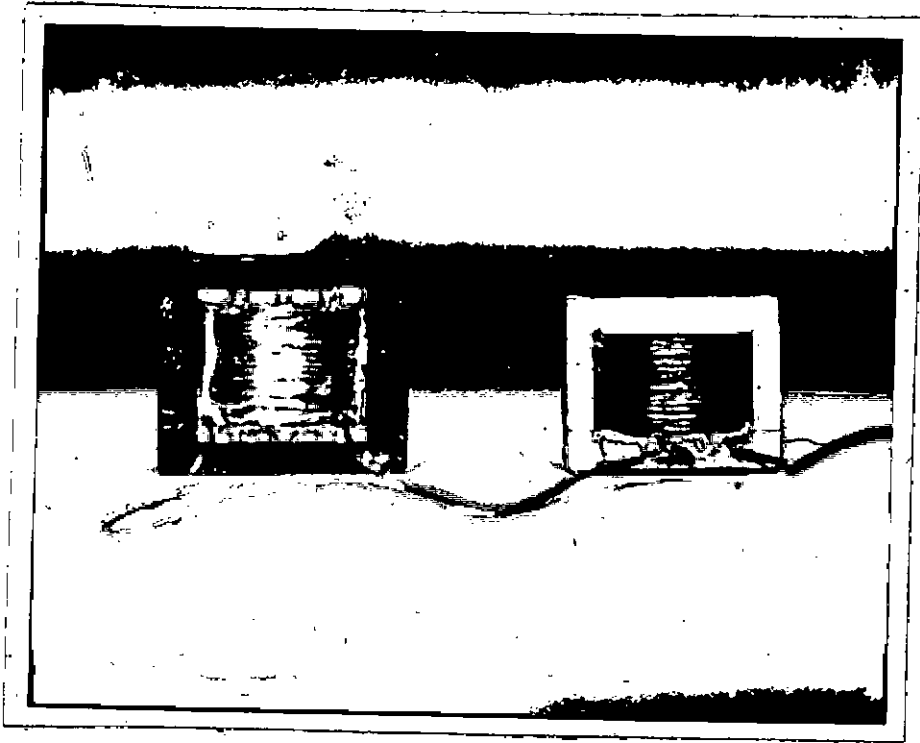

Fig. 3.15 Input-output Transformer.

$$N_p = 1600 \text{ turns} \quad N_s = (500 + 500) \text{ turns.}$$

Wires used in the primary and secondary are

42 SWG 40 SWG respectively.



Photograph 3.4  
Input-Output Transformer



### 3.5 FERRITES

3.5.1 General: The ferrite is a magnetic oxides. Its chemical formula is  $MO Fe_2O_3$ , where M is a divalent cation, often Zn, Cd, Fe, Ni, Co or Mg. In the magnetite,  $Fe_3O_4$  or  $FeO \cdot Fe_2O_3$ , Ferric ( $Fe^{3+}$ ) ions are in a state with spin  $S=5/2$  and zero orbital moment. Thus each ion should contribute  $5 \mu_B$  to the saturation moment. The ferrous ( $Fe^{2+}$ ) ions have a spin of 2 and should contribute  $4 \mu_B$  apart from any residual orbital moment contribution. Thus the effective number of Bohr magnetons per  $Fe_3O_4$  formula unit should be about  $2 \times 5 + 4 = 14$  if all spins were parallel. If the moments of the ferric ions are antiparallel to each other then the observed moment arises only from the  $Fe^{2+}$  ion. If the  $Fe^{2+}$  are replaced by divalent metallic ions such as Cu, Ni, Mg, Zn or Mn a material of ceramic type structure is produced with high permeability and resistivity known as ferrites.

Hilpert (3B,5) first produced such substances having high resistivity, but he was unable to obtain high permeabilities and it was left to Snock to attain their aim by use of sintering process. To obtain low hysteresis loss and high initial permeability it is essential to manufacture a material with low stress by utilization of the cubic crystal structures which has equal shrinkage in all direction during cooling, and two types of Ferrites often used to-day for construction of low loss cores are both mixed crystals of two ferrites-  $MnZn$  and  $Ni Zn$ . Each of these basic types is obtainable in several variant forms, and resistivity ranges from  $10^{-2}/cm$  to  $5,000,000 \Omega/cm$  and initial permeability from 20 to 1,500. Saturation flux is lower than most metallic magnetic alloys and decreases appreciably with increasing temperature, and although effective permeability does not vary excessively with temperature over the range of low flux densities, this saturation causes extreme variation with temperature at high densities. For all grades of Ferrites there is a critical temperature above which the initial permeability falls suddenly to a negligible value, and this temperature varies for grades now available from  $120^\circ C$  to  $550^\circ C$ . At low values of induction permeability increases with increase of temperature, while for high induction it falls, and by choosing a critical value of polarizing field it is possible to construct an inductor with constant inductance over a narrow temperature range.

Losses in ferrite : The losses in a ferrite will be the sum of three components.

(a) Losses due to hysteresis, increasing with maximum flux and with frequency.

(b) Losses due to eddy currents which are very small for most applications due to the high resistivity of ferrites.

(c) The residual losses, which for low induction represent the major contribution to the total loss.

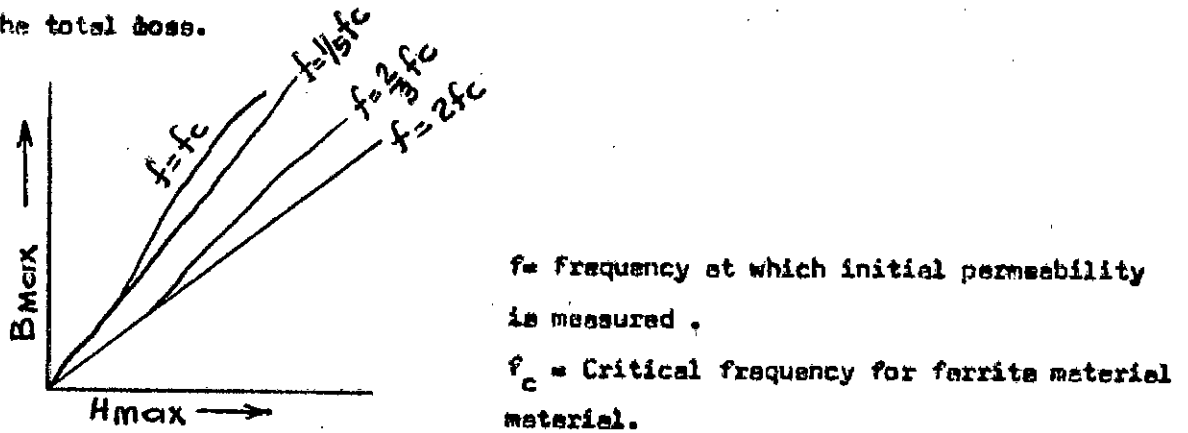

Fig. 3.16 Initial permeability curves of ferrites  
Frequency curve of ferrites.

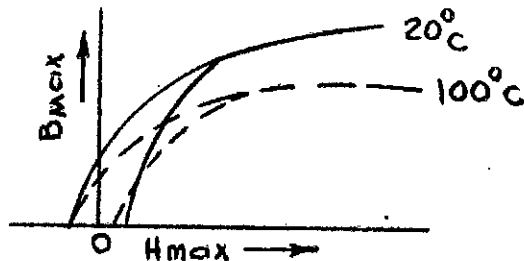

Fig. 3.17 Typical Magnetization curves of Ferrites.

The dimensional effect: Dimensional effects may occur when ferrites, are used at high frequencies. In fact the material is not completely loss free. Magnetic hysteresis occurs, together with other losses associated with the magnetic field, and there are further dielectric losses associated with the electric field. As a result both  $\mu$  and  $\kappa$  are complex quantities and, even when quarter-wave dimensional resonance occurs,  $Z_c$  will not become zero. It will however fall to a small value, accompanied by a considerable change in its phase angle, so that, as the critical frequency is approached, both the inductance and the Q of the inductor will fall. Since ferrite materials may combine a permeability of about 1000 with a permittivity of the order of 100,000, the wavelength for a given frequency, which is proportional to  $\frac{1}{\sqrt{\mu\kappa}}$  will be only about 0.10% of the corresponding value for free space. At a frequency of 1Mc/s, the wavelength in the ferrite material, instead of being about 300 metres, will be only about 3 cms, so it will be realized that dimensional effects can present an important practical problem.

## 3.5.2 Manufacturing Process:

Mn. Zn. Ferrite (24)

The relation between sintering temperature grain size and magnetic properties of a manganese zinc ferrite of composition.



are reported with proper preparation, very low loss material can be obtained.

A little amount of wet substance is mixed with liquid and is kept in a pot for a few days. Then this mixed substance is sieved out and is dried at  $110^\circ\text{C}$ . It is then squeezed through a net of 20 or 100 mesh. This mixed substance is then in the process of pre-sintering for about 15 hours in an oven at a temperature of  $900^\circ$ ,  $1100^\circ\text{C}$  and the spinel ferrite is produced. Gradually it becomes gray or black from red iron oxide. It is dried in the air or at about  $110^\circ\text{C}$ . It is then pressed at a pressure of 6000 psi. It is heated to a temperature of  $1100^\circ - 1400^\circ\text{C}$  in a desired shape dice and is cooled to a controlled temperature.

R

Of all ferrites Mn Zn ferrites are of the greatest practical importance to day. The reason for the superiority over the other ferrites, such as Ni-Zn ferrite is the higher saturation magnetization, the lower losses, and a relatively high curie point. This is due to the fact that Mn ion has 5 Bohr magnetons while the Ni ion, for instance, has only 2.3. In addition, magnetostriction and crystal anisotropy of the Mn-Zn ferrite are very weak. Minor addition of  $\text{Fe}_3\text{O}_4$  can reduce the magnetostriction to almost zero, which is necessary if low hysteresis losses are to be achieved. The residual loss is very small, too, since the reaction between the oxides. MnO-ZnO- $\text{Fe}_2\text{O}_3$  is more complete than in the other known ferrites.

## Low loss Mn Zn ferrites (24, 35)

Magnetic properties as a function of sintering temp :

The grain structure obtained in the finished ferrite is of great importance, because it is found that, chemical composition and degree of purity being equal, the magnetic properties reach optimum values in the case of a crystal aggregate consisting of very regular crystals of equal size with sharply defined boundaries. These ferrites always have inter crystalline fractures. The desired crystalline structure depends in no small measure upon the material used and the condition under which it is pressed.

## Flow Chart for Manufacturing of Ferrite.

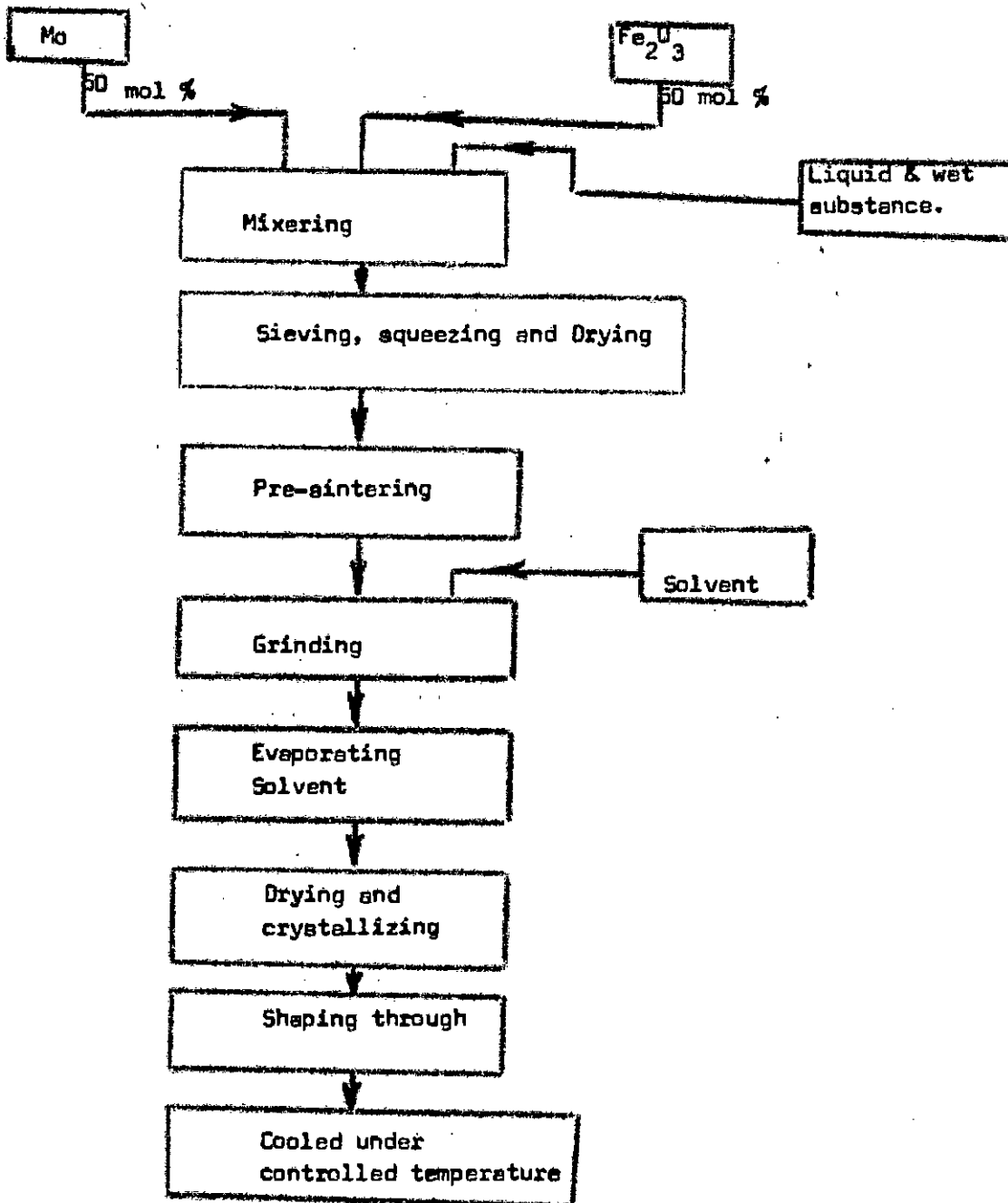

The sintering temperature is a very decisive factor that influence mainly the size and shape of the individual crystals.

We are concerned here with a Mn-Zn ferrite of the molecular composition  $MnO - ZnO - Fe_2O_3 = 28 : 19 : 53$ . With a curie point at  $180^\circ C$ . It is important that all Mn exists in bivalent form and that the excess  $Fe_2O_3$  is converted into  $Fe_3O_4$ , so that we obtain a homogeneous mixed crystal of Mn-Zn re ferrites. In order to obtain this it is necessary to have a well-controlled sintering atmosphere.

(a) Initial permeability and saturation: The initial permeability and saturation induction are dependent on sintering temperature. Permeability rises from 1000 upto 4000 at  $1365^\circ C$  and decreases again at higher sintering temperatures. Saturation induction increases upto  $1820^\circ C$  and then approaches a limiting values of 4800 G. This rise is very probably due to the increase in density alone.

(b) Residual, hysteresis and eddy current losses: Apart from permeability the losses are of decisive importance for ferrites to be employed in high frequency application. By measuring their frequency and amplitude frequency these losses can be separated into the so called Jordan loss coefficients which can easily be converted into the constants introduced by Legg and Givern.

So we find

$$e = w/\mu \quad c = \pi/\mu \quad a = \frac{h}{\mu^2} \frac{1}{1775}$$

These quantities are not affected by air gap, so that a composition of various materials is possible.

The hysteresis coefficient 'a' after Legg is dependent on the sintering temperature. This value is directly proportional to the distortion factor and has a minimum of  $.16 \times 10^{-6}$  cm/ A at a sintering temperature of  $1290^\circ C$  measured at a frequency of 5 KC. It is extremely low and in comparison with conventional ferrites the hysteresis loss is 10 times smaller. The grain size for this optimum value lies between 5 and  $10 \mu$ . Above  $1340^\circ C$  and below  $1260^\circ C$ , the hysteresis coefficient increases considerably.

The eddy current coefficient too, varies with the sintering temperature and reaches its optimum value of  $.18 \times 10^{-9}$  sec at  $1260^\circ C$ . This value is 2 times smaller, compared with the conventional ferrites.

The residual loss coefficient 'c' after Legg has a minimum value of  $4 \times 10^{-6}$  at  $1280^{\circ}\text{C}$  and thus it is 4 times smaller than that of the conventional ferrite.

The value of practical interest, namely  $t_g \frac{\delta}{\mu}$  is  $1.2 \times 10^{-6}$  at a frequency of 10 Kc and about  $4 \times 10^{-6}$  at 100 Kc.

Summarizing we may state that the optimum values for permeability and losses are obtained at different sintering temperatures.

TABLE 3.5.1

Values of Residual, Eddy current and Hysteresis losses Coefficients of Different Ferrites.

	$\mu$	$c \cdot 10^6$	$a \cdot 10^6$	$e \cdot 10^9$
Permalloy powder cores	125	30	1.6	19
	60	50	2.5	10
Carbonyl powder cores	58	79	9.5	7
Hyperox D <sub>1</sub> (Conventional ferrite)	1800	22	1.41	.55
Hyperox D <sub>1</sub> S <sub>2</sub>	2600	6.5	6x5 .16	.21
Hyperox D <sub>1</sub> S <sub>1</sub>	4000	31	.62	.74

Interpretation of results on the basis of general theory on Ferromagnetism.

On account of their constitution and characteristic shape, the individual crystals have a small crystal and strain anisotropy, and it is easy to visualize that magnetization within them is only determined by the shape anisotropy of the surrounding pores. However the shape anisotropy of such a grain structure is small because the pores are very regular and approximately spherical in shape with the result that the demagnetization factor is equal in all directions so that magnetization can easily be affected by rotation. In addition, such a grain structure assures a uniform flux distribution throughout the polycrystalline ferrite, and therefore gives a low hysteresis loss. Moreover, a homogeneous crystalline structure is a sine qua non if a homogeneous flux distribution and thus a small hysteresis loss is to be obtained.

The small eddy current coefficient of this ferrite can also be explained by grain structure, which may be considered to be quasi homogeneous consisting of grains separated from each other by a nonconducting interstitial layer. Grain growth causes the relatively high specific resistance to decrease considerably.

The residual loss is also small because any impurities that may be present are located within the interstitial spaces where they exert no disturbing influence on magnetization.

Octahedral site preference energies for various cations. Value of P are in k cal/g atomic weight, radius in  $\text{A}^{\circ} = 10^8 \text{ cm}$ .

**TABLE 3.5.2** (24,37)

Values of Ions, Magneton numbers and Radius of Ferrite Materials

Ion	P	r
$F_{\text{o}}^{++}$	9.9	.75
$N_{\text{n}}^{++}$	14.7	.8
$Mg^{++}$	5	.65
$N_{\text{i}}^{++}$	9	.69
$N_{\text{n}}^{++}$	31.6	.74
$Cd^{++}$	29.1	.97
$C_{\text{o}}^{++}$	10.5	.72
$AL^{+++}$	2.5	.5

**TABLE 3.5.3**

Characteristics of Screw Ferrites Manufactured by Semiconductor Limited India.

Type No.	Application	Dia m.m.	Length m.m.	Pitch m.m.	Description
A1 S11	SxR	3.8	14	.75	Ferrite blank in threaded plastic sleeve.
A1 S12	Medium	4.0	10	-	Unthreaded ferrite blank.
A1 S13	Wave	4.0	10	.75	Threaded ferrite core.
A1 S14		4.0	7	.75	"
A1 S15		3.5	10	.75	"
A3 S12		4.0	10		Unthreaded Ferrite blank
A3 S13	Short	4.0	10	.75	Threaded
A35 14	Wave	4.0	7	.75	Ferrite core
A 3 S 16		4.0	16	-	Unthreaded Ferrite blank.

Note:- These ferrite cores can be used as tuning slugs in radio IFT and similar coils.

Ferrites manufactured by Mullard (16) *High frequency grades B<sub>2</sub>, B<sub>5</sub> NiZn - Ferrite cube*  
 Low frequency grades A<sub>1</sub>, A<sub>4</sub> - Mn Zn Ferrite cube. *Normally, grades A<sub>1</sub> and A<sub>4</sub> are*  
 expected to be used of frequencies upto 500 kHz ; above this frequency and upto about  
 10 MHz, grade B<sub>2</sub> should be used; above 10 MHz grade B<sub>5</sub> is recommended.

TABLE 3.5.4

Characteristics of Rod Ferrites Manufactured by Mullard.

Nominal	Diameter d. mm		Length(l) mm		Material Grade	Type No
	Max <sup>m</sup>	Min	Max	Min		
1.6	1.65	1.55	12.2	11.0	B <sub>2</sub>	FX 2902
1.6	1.65	1.55	14.2	13.0	B <sub>5</sub>	Fx 1433
6.4	6.55	6.15	32.76	30.74	A <sub>4</sub>	Fx 1089
12.7	13.08	12.32	78.4	74	A <sub>4</sub>	Fx 1172



### 3.6 RESISTORS

**3.6.1 General :** Resistors form the major part of the components that go into the fabrication of communication and electronics equipments. Resistance is a property of a conductor that depends on its dimensions, material, and temperature, and which determines the current resulting from a given difference of potential across the resistance.

**Temperature Coefficient of resistance:** This is a measure of the change of resistance of a resistor with temperature, referred to some base temperature. The temperature coefficient is usually expressed in percent per degree centigrade.  $25^{\circ}$  is taken as the reference temperature.

**Voltage Coefficient of resistance:** This is the measure of change of resistance of a resistor with applied voltage. It is a negligible factor with wire wound resistors, but must be taken into consideration in the case of composition types. It is usually expressed in percentage. Composition resistors of  $\frac{1}{4}$  watt rating and greater may be a voltage coefficient of .02% per volt.

**Power rating:** The nominal power rating of a resistor is an arbitrary figure that indicates the heat in watts the resistor can dissipate under specified ambient condition, usually  $25^{\circ}\text{C}$  in still air. This rating is based on the max temperature that any point on the resistor body will be permitted to reach ( hot spot temperature) and characteristics of the resistor body itself. If the resistor will be damaged by higher temperatures, under other than the specified ambient conditions, the actual rating must be changed so that the maximum temperature is never exceeded.

**Voltage rating:** The rated continuous working voltage of a resistor of low or medium resistance is the voltage which makes it dissipate its rated power under the specified ambient condition. It is determined by  $E = \sqrt{PR}$

Where P = power rating in watts.

R = Resistance in ohms.

E = Max<sup>m</sup> continuous voltage in volts.

If A.C. is applied , E is the rms value and P is the average power. The voltage necessary to make the resistors of high value dissipate their rated power would be very high. In such cases the voltage rating is based on the permissible voltage gradient and the dielectric strength of the materials in the resistor.

**Tolerance:** This is a figure, expressed as  $\pm$  a percentage that indicates to the user the range within which the resistance of the particular resistor is guaranteed by the manufacturer to fall when purchased.

**Stability:** The stability of a given resistor depends upon the dissipated power and ambient temperature. High power may be dissipated at low ambient temperatures, whilst lower dissipation results in improved stability. With a knowledge of the relationship between ambient temperature, power dissipation and stability, the circuit designer is able to select the most suitable resistor for his application. Mullard has developed a monogram<sup>(17)</sup> which shows the inter dependence of the three variables and was evolved as follows:-

Power dissipation in a resistor causes an increase in the temperature of its body. The temperature rise is governed by the laws of heat conduction, convection and radiation and will show a maximum in the middle of the resistor body if it is of symmetrical construction. Theory and experiment have shown that for the temperature range where radiation plays only a minor part (this is the normal operating temperature range of film resistors), the maximum temperature rise  $\Delta T$  is proportional to the power dissipated, or

$$\Delta T = AP \quad (3.53)$$

The constant  $A$  gives the temperature rise in the middle of the resistor body per watt of power, and can be interpreted as a heat resistance with the dimensions of degrees C per watt. The heat resistance is the function of the resistor, the conductivity of the materials used and, to a lesser degree, the method of mounting it.

The sum of the temperature rise and ambient temperature is the maximum temperature  $T_{max}$  of the resistor.

$$\Delta T + T_{amb} = T_{max} \quad (3.54)$$

The stability of a film resistor under load is primarily determined by its hot spot temperature and the materials used in its construction. Since the construction is the same for all resistance values, the heat resistance is a function of body dimension. The dissipation is expressed as a function of hot spot temperature, with ambient temperature as a parameter.

$$P = \frac{T_{max} - T_{amb}}{A} \quad (3.55)$$

Noise: All resistors generate a voltage into an open circuit because of the thermal agitation of the molecules of the resistor. Noise is of such a magnitude that it is important to the designer of very sensitive radio receivers. In addition composition resistors develop a noise voltage across them when they carry currents.

### 3.6 Manufacturing process of Tin oxide resistors.<sup>(40)</sup>

Raw materials: The various raw materials required in the process are :

Ceramic pieces,	Chemicals,
Caps,	Solder,
Paint & Marking,	Silica tube consumption,
& Miscellaneous Hch, Hf	PVC tubes.

Equipment : The essential items of plant and machinery are :

Chemical Balance,  
 Tubular coating furnaces with temperature controllers Temperature of operation,  
 Evaporating furnace,  
 Drying ovens,  
 Silica tubes,  
 F.H. Motor with reduction gears,  
 Capping Machine (estimates),  
 Spiralling machine ( do)  
 Soldering pot with ~~xxxxxx~~ sunvic controller,  
 Laboratory type compressor  
 Marking die.  
 Test Equipment :-  
 Resistance bridge,  
 Variable voltage source (High voltage low current).

Process: This consists in forming the tin oxide film with suitable electrical characteristics by passing vapours of stannic chloride or to the substances kept at sufficiently high temperatures so that stannic chloride hydrolyses to form a hard and fairly uniform coatings of  $\text{SnO}_2$  on the surface of the substrates. To have high stability, low resistivity, and acceptable electrical characteristics, the  $\text{SnO}_2$  film is doped with a little amount of antimony.

Characteristics : The oxide film formed on the substrate (Ceramic) is transparent, hard and chemically stable.

The film formed actually so fuses into the substrate with a molecular bond that it becomes extremely hard and resistant to abrasion. The resistors formed of stannic oxide film are not affected by atmospheric moisture. The film is harder than the substrate and can be heated to an incandescence without basically injuring the substrate. The runaway failure which results with carbon film from reduced resistance at a hot spot, is absent in the case of  $T_{in}$  oxide resistors due to their excellent stability under sustained over load. The problem of leakage at high operating temperatures which is severe in other types of resistors, is absent in the case of tin oxide resistors.

# FLOW. DIAGRAM

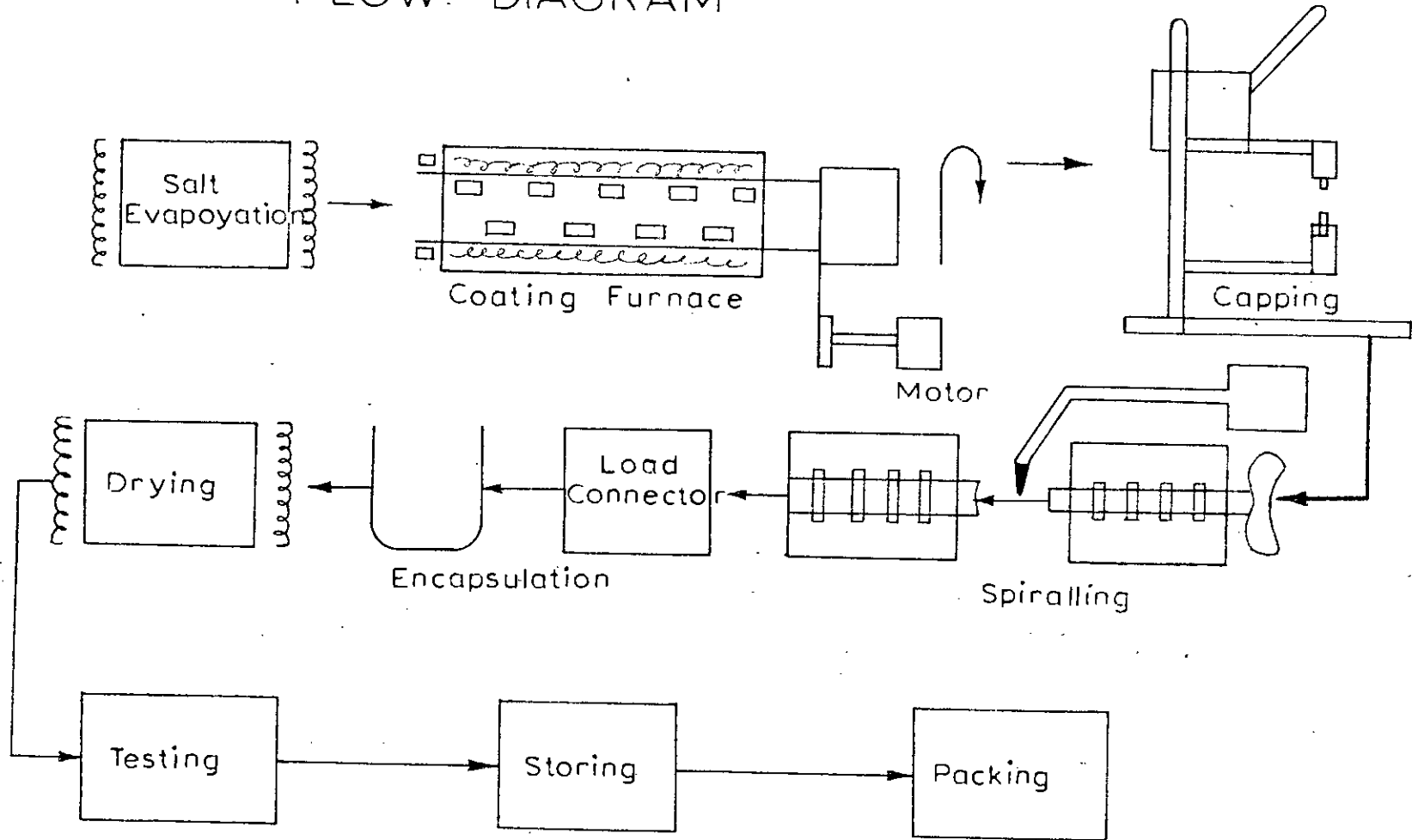

### 3.6.3 Manufacturing process of Carbon film resistors (40)

**Raw materials:** Ceramic rods, chemicals for tinned copper leads, and caps, varnish and encapsulating materials.

**Plant and machinery:-** Tabular cracking furnaces, automatic or semi-automatic spiralling machines, capping machines, head attachment machines, soldering equipment, varnish coating equipment, marking marking equipment, automatic resistances, sorting equipment, insulation testers, high voltage testers, noise measurement equipment, endurance testing ovens, humidity chambers, cold chambers and other test facilities.

**Process:** The process consists of pyrolytic alloy cracking carbon film on ceramic rods. The exact values of resistance are then spiralled to accuracies required. The resistors are given a protective varnish coating and are also encapsulated in suitable epoxy materials or hermetically sealed.

**Specification of product :-**

**Wattage :** 1/8 to 3 watts.

**Range :** 1  $\Omega$  to 10 mega  $\Omega$

**Tolerance :** 5% and 10% .

### 3.7 CAPACITOR

3.7.1. Ceramic Capacitor : Although Ceramic capacitors were entered on the electronic components list only recently, they have come to be very important members of the capacitor family.

Essentially a ceramic capacitor consists of a ceramic dielectric on which has been fired at very high temperature a thin metallic film, usually silver, which forms the electrodes. Because the temperature characteristics of ceramic dielectrics can be pre-determined by varying their compositions, the capacitances of a ceramic capacitor can be predicted for any temperature. Since the change in capacitance is not a permanent shift the capacitance temperature characteristic for any ceramic capacitor will remain reasonably constant in its specified temperature range with time. This property of the temperature compensating ceramic capacitor makes it valuable in compensating for other elements in circuit which do not have controllable temperature characteristic. This is particularly important in resonating or oscillating circuit where the time constant (RC or RL) must remain within design limits.

Advantage and disadvantage : The principal points to be noted concerning ceramic capacitors are as follows :-

1. Ceramic capacitors have a high capacitance per unit volume or mass.
2. Typical characteristics include high dielectric constants; polarization

saturation, and ferroelectric hysteresis.

3. Under certain condition, notably high temperatures coupled with rapid pressure changes, ceramic capacitors may exhibit a piezo electric effect. Once a ceramic capacitor has become piezo-electric it will always have that characteristic . Consequently, the self generated voltages induced by the behaviour may interfere in circuits having very low signal to noise ratio.
4. Since ceramic capacitors are relatively brittle they may be damaged by shock and vibration.
5. Time and temperature will give rise to a mild amount of aging and capacitance decay.
6. Over voltage applied will adversely affect ceramic capacitor life. Experimental data indicate life is inversely proportional to the cube of the voltage.

#### Manufacturing Process <sup>(41)</sup> :

Raw materials : various types of basic raw materials like oxides of barium titanium, calcium tinned copper leads silver paste and phenolic encapsulating resins.

Plant and machinery: Furnaces, tabling machines, ball machines, cracks and mixers, Extrusion process, marking equipment, various types of electronic testing equipment, loss angle measuring equipment, capacitance sorters, etc.

Process: Ceramic capacitors are made out of a mixture of oxides of barium titanium, calcium and small quantities of  $\text{BaO}$  oxide and cerium oxide. The process generally is that adopted in the ceramic industry, viz. mixing the oxide in the right proportions in special ball mills, pressing the powder mixed with suitable binder to the requisite shape and then sintering the pieces at high temperatures. The discs so formed are electroded by a pro-chemical process using silver oxide as a base. Tinned copper leads are soldered on to the electrodes and the entire piece is given a protective coating of a phenolic resin.



TABLE 3.7.1 (10)

Characteristic	Classification of Ceramic capacitors	
	Class I dielectric	Class II dielectric
Dielectric constant at 25°c	6 to 500 at 1 mc and .5 to 5 r.m.s. volts	500 to 10, 000 at 1 KC and .5 to 5 rms volts.
Temperature coefficient of capacitance pp p/c	P 200 to N 5600	Not specified.
Power factor at 25°c	.04 to 4% at 1 mc and .5 to 5 rms volts	4 to .3% at 1 kc and less than 5 r.m.s. volts.
Insulator resistance at 25°c at 100 to 500 volts 1 minute of electri- fication	7500 to 10,000 meg ohms	7500 to 100,000 M-Ω
Maximum capacitance decrease (-55° to + 85°c with reference to 25°c)	0 to 40%	0 to 80%
(-55, to + 85 c with reference to 25°c)	0 to 40%	0 to 50%
Maximum operating temperature	85°c	85°c
Aging dielectric constant	Small	App 4% per decade of time (= √2)
Capacitance range in <i>μμf</i> min	1	5
max	5000	10,000
Tolerance %	min	10
max	20	-0, + 100
Voltage range	min	150 V
Standard	500 V	500 V
Max	6000 V	6 to 30 KV
Temperature range	min	-55
(c)	max	125

Class I dielectrics are used in capacitors requiring good capacitance stability & low power factor and where minimum size is not required. Titanium dioxide is of class I dielectric.

Class II dielectrics are used where large changes in capacitance and high losses are not critical and small size is required. Titanium dioxide had a dielectric constant of about 120 and a negative temperature coefficient of about 1000 parts/million/day<sup>2</sup>.

### 3.7.2 ELECTROLYTIC CAPACITOR : (17)

All electrolytic capacitors have a dielectric which comprises an oxide layer. This layer is produced by an electro chemical process known as forming and the thickness is a function of dielectric strength and hence the voltage rating.

In the case of a non solid electrolyte, the anode (+) foil often has a roughened surface which effectively increases the surface area and thus enables very high capacitances with respect to the volume. This foil is formed and subsequently wound together with a cathode (-ve) foil, interleaved with an absorbent paper tissue. The assembly is then impregnated with an electrolyte (which is the true cathode) and finally sealed in an aluminium case.

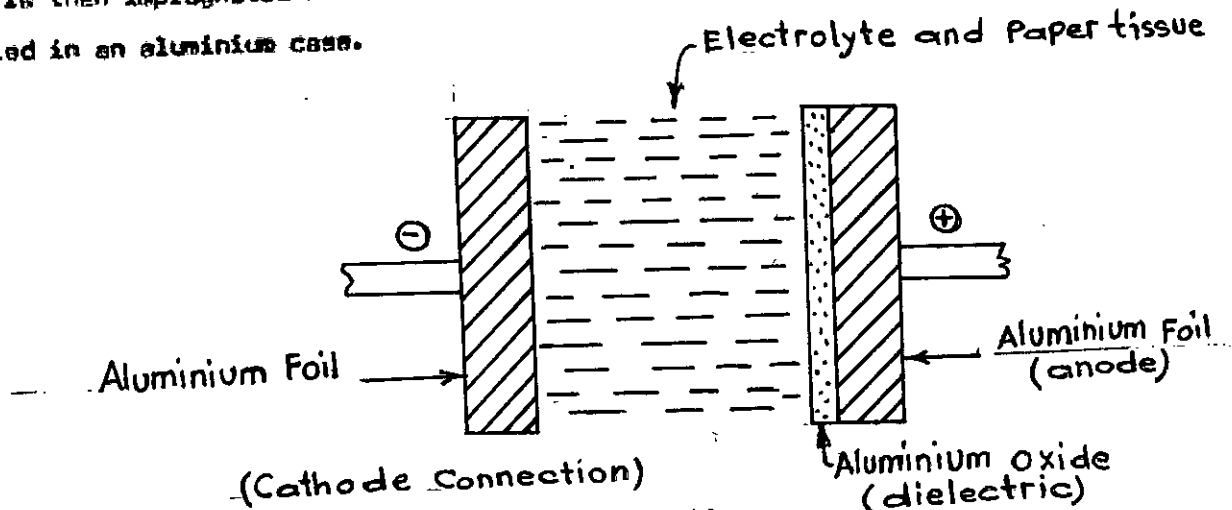
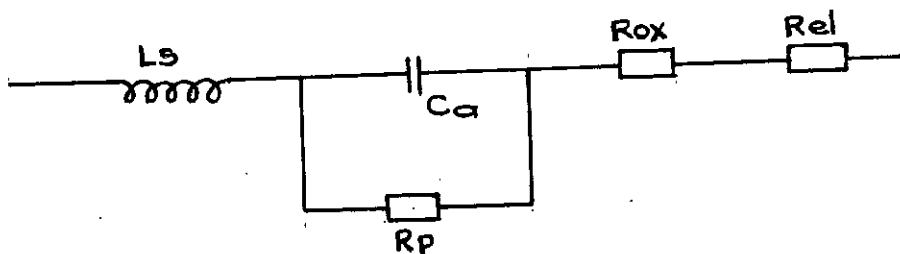

FIG 18  
Equivalent circuit : The equivalent circuit of a non solid electrolytic capacitor is given below :-



Where  $C_0$  = Capacitance at the anode.

$R_p$  = Parallel resistance or leakage current.

$R_{ox}$  = Series resistance of the oxide layer.

$R_{el}$  = Series resistance of the non solid electrolyte and paper tissue.

$L_s$  = Series inductance.

The equivalent series resistance  $R_s$  of the capacitor is given by

$$R_s = R_{ox} + R_{el}$$

$$\text{or } R_s = \frac{\tan \delta}{\omega C_s} \quad (3.55)$$

This resistance is an important property as it is responsible for the heating effects of ripple currents. It varies inversely with temperature and is also related to capacitance and frequency.

The following measurements are of principal interest to the designer .

1. Capacitance  $C_a$ , measured at 100 Hz.

2. Loss factor or  $\tan \delta$  measured at 100 Hz.  $\tan \delta = 2\pi f R_s C_a$

3. Impedance  $Z$ , where  $Z = \sqrt{R_s^2 + \left[ \frac{1}{2\pi f C_a} - 2\pi f L_s \right]^2}$

At various frequencies, the following simplified formulae for  $Z$  may be used :

$$\text{at } 100 \text{ Hz} \quad Z = \frac{1}{2\pi f C_a} \approx \frac{1}{\omega C_a}$$

$$\text{where } f \text{ is the measuring frequency at } 1000 \text{ Hz} \quad Z = R_s = R_{el}$$

$$\text{at } 1000 \text{ MHz} \quad Z = 2\pi f L_s \approx \omega L$$

Tan  $\delta$  and series resistance

The losses in an electrolytic capacitor are the series resistance  $R_s$ . It is sometime called ESR and can be calculated from  $R_s = \frac{\tan \delta}{\omega C_s} = \text{ESR}$ .

Where  $\delta$ , the loss angle is the complementary angle to the phase angle  $\phi$ . The vector diagram shows that the current leads the voltage by slightly less than the theoretical  $90^\circ$

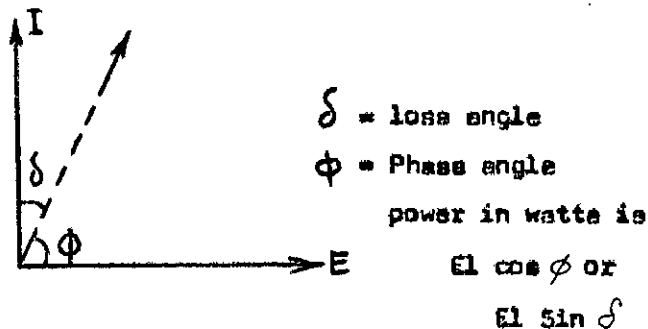

**Voltage:** The voltage rating is dependent on the thickness of the oxide layer and it should not be exceeded except for limited periods. The applied voltage may be the sum of a d.c. component plus a superimposed a.c. voltage and the sum of these two should not exceed the rated voltage. The operation of capacitors with applied voltage less than the rated voltage has no adverse effect. Leakage current (solid electrolyte)

In the case of aluminium capacitors with solid electrolyte the leakage current is  $< .1$  CV expressed in  $\mu$ A.

**Temperature :** Electrolytic capacitors have a positive temperature coefficient which is dependent on the voltage rating. The voltage rating of a non-solid electrolyte capacitor is dependent on the electrolyte, whose characteristics are chosen to provide adequate life at high temperatures, and a tolerable increase in impedance at low temperatures. The actual life is determined by a drying out of the electrolyte.

**Service life:** The service life is dependent on the ambient temperature of operation and for life in case of solid electrolyte is usually much greater than non solid or liquid electrolyte and is not so dependent on temperature as non solid ones.

**Manufacturing process of Aluminium Electrolytic capacitor: (40)**

**Raw materials :** The raw materials required for the manufacture of electrolytic capacitors are :

- Aluminium can,
- Aluminium wire
- Plain Aluminium foil for anode for cathode.
- Electrolytic tissue paper for-warding,
- Tinned copper wire.
- N.C. Adhesives.
- Anchoring compound,
- Rubber caps,
- Electrolytic,
- Chemical and
- P.V.C. sleeves.

The essential items of plant and machinery needed in the process are

Etching plant  
 Forming plant  
 Demineralising plant,  
 Automatic foil slitting machine with a facility for foil cutting.  
 Automatic tab stitching machine  
 Aluminium wire cutting machine  
 Welding unit,  
 Tal press for flattening press,  
 Rivetting and flattening press,  
 Automatic winding machine,  
 Impregnation plant,  
 Centrifuge extractor,  
 Curling and sleeving machine,  
 Aging power supply,  
 Capacitor sorter,  
 Sleeve shrinking,  
 Printing machine,  
 Ovens and  
 Table balance.

Process: Basically, the aluminium electrolytic capacitor consists of an anodized aluminium anode foil, a paper separation, an aluminium cathode foil an electrolyte and a cap to hold the assembly. Based on the placement of the electrolyte. These capacitors can be divided into two types (I) Wet electrolytic (II) dry electrolytic wet electrolytic capacitors contain free electrolyss. Dry electrolytic capacitors will not contain free or spillable electrolyte.

The general method from the manufacture of aluminium electrolytic capacitors is given the accompany flow sheet. The major steps are .

Etching,	Forming,	Slitting,
Stacking,	Winding	Impregnation,
Assembly,	Aging,	Sorting,
Sleeving,	Marking	and Packing,

Aluminium Electrolytic Capacitor  
 Flow chart.

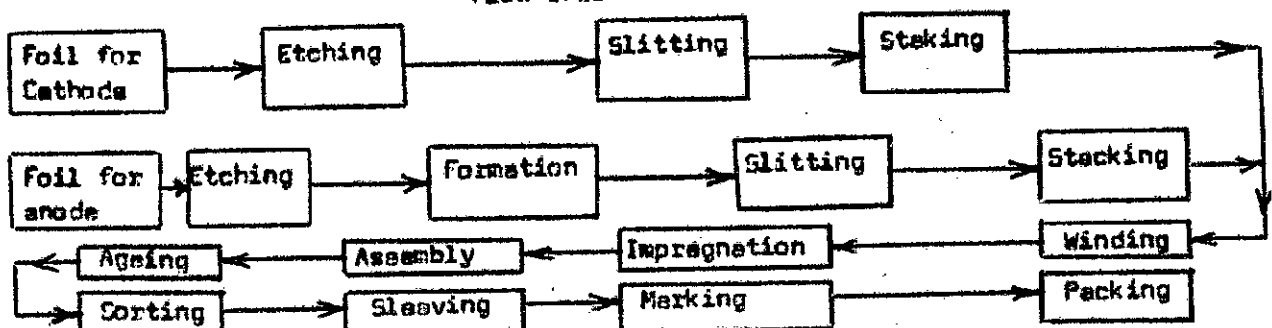

### 3.8 TRANSISTOR

3.8.1 General : The common transistor is a three-terminal device and is referred to as a tetrode. It is formed from layer of p and n type semiconductor materials as shown symbolically in Fig.



Fig. 19 N- P-N and P-N-P Transistors

Both n-p-n and p-n-p structures are manufactured and are in common use. The section are designated emitter, base and collector, and the structure contains two p-n junctions. Although diode junction exist in the device, performance of a transistor is not that of two back to back diodes.

In the manufacture of transistor usually two methods are used. Alloying and Diffusion process are the two techniques. Here we will describe alloying method of transistor for manufacturing which is simpler of the two.

3.8.2 Alloy junction transistor : The general features of both p-n-p and n-p-n alloy transistors fabrication processes are illustrated in Fig. 3.20 Germanium single crystals suitable for alloy transistor is to be used. These crystals, after measurement to ensure proper conductivity type, resistivity, minority carrier, life time and dislocation etch-pit density, are shaped into thin flat wafers. Alloying, the critical step in transistor fabrication, requires that doping materials of controlled composition and uniform mass and shape wet correctly positioned, defined areas of the wafer.

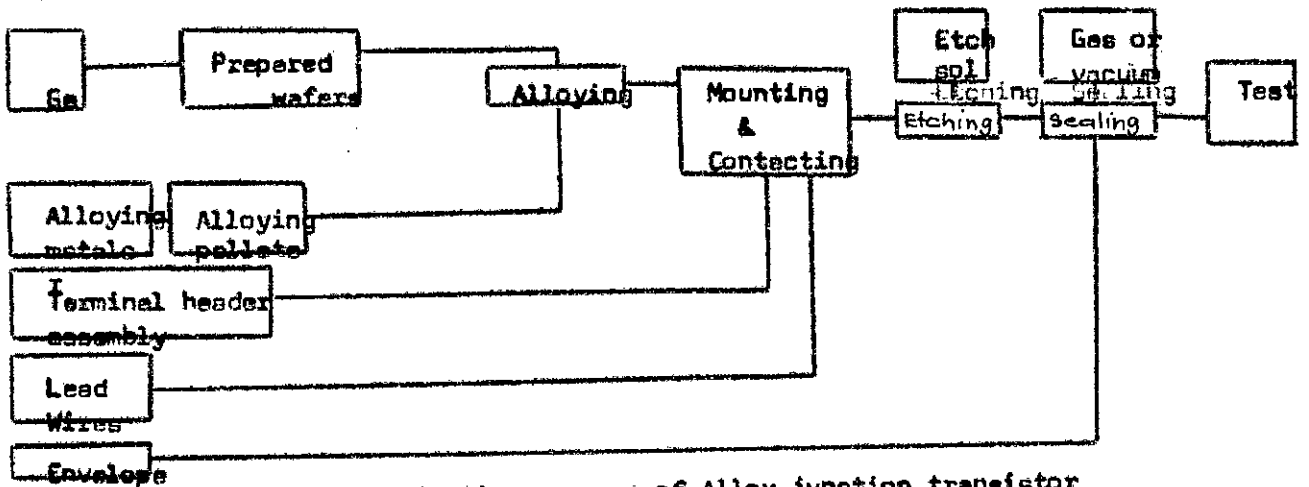

Fig. 3.20 Fabrication process of Alloy junction transistor

The alloying temperature ~~must~~ time cycle must be accurately reproduced to bring about consistent melting depth in the wafer and adequate regrowth of doped germanium. Good electrical and thermal conduction must be made between the basic transistor element, illustrated in fig. 3.2.1 and terminals of the device, avoiding mechanical stress in the germanium, chemical process for the removal of shorting layers and contaminants on the transistor element and the production of stable states on the active germanium surface are required for optimizing electrical characteristics and realizing maximum reliability. A vacuum-light encapsulation is equally necessary for high reliability.

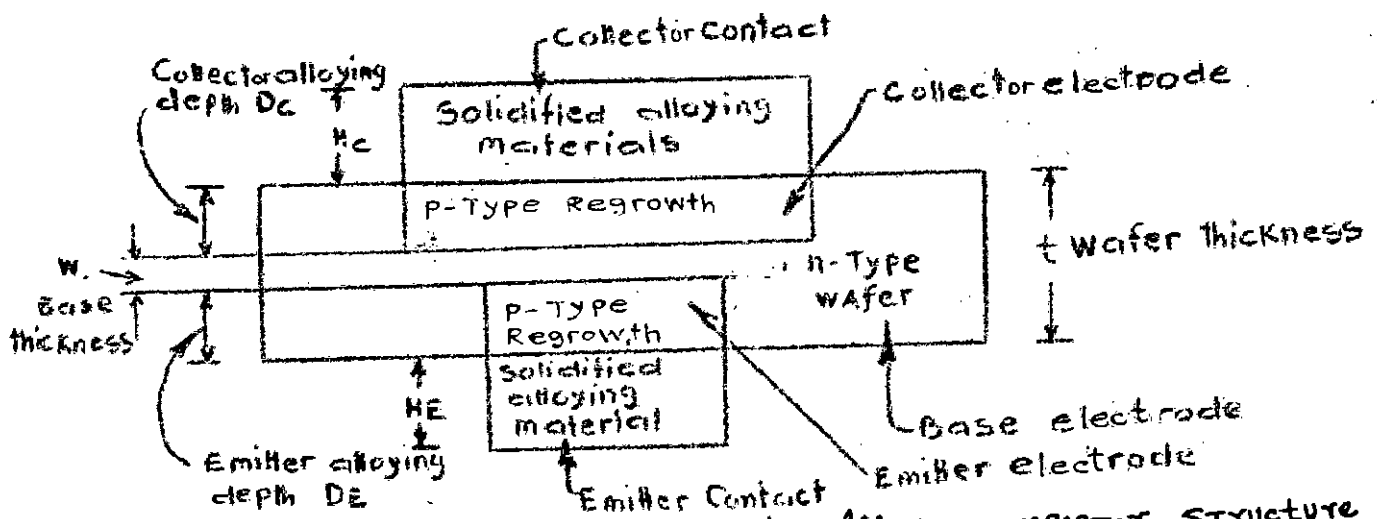

FIG 3.21 Idealized Alloy Transistor Structure

Alloy transistors have the following characteristic features. The junctions usually are step junctions. The collector region is more highly width, punch through will occur because most of the depletion layer of the collector junction extends into the base region. The collector series resistance is very small.

**4.8 TRANSISTOR ELEMENT FABRICATION:** The product of the transistor alloying process is a single-crystal germanium wafer having three regions that alternate in respect to conductivity type, either p-n-p or n p n. These region are formed by placing spherex or discs of doping material on opposite side of a prepared wafer, and heating to allow the dope to melt and dissolve part way into the wafer. As the molten alloy is cooled carefully, dissolved germanium recrystallizes at the liquid-solid interface of the wafer which acts as a single crystal seed. The regrown germanium is now doped to the opposite conductivity type from the base wafer since it contains, in solid solution, some of the doping element of the alloying metal.

The resulting transistor crystal will be n-p-n or p-n-p in conductivity type for emitter-base collector respectively depending upon the germanium type and the nature of the doping materials alloyed into the germanium wafer. Control of properties of these three regions of the element and of the two semiconductor junction between them is basic to the production of transistors of uniform characteristics.

#### 4.8.4 TYPICAL MATERIALS UTILIZED IN TRANSISTOR FABRICATION

##### 1. Doping Elements:-

Gallium, Indium, boron, aluminium, Phosphorous, antimony and Arsenic. Also certain oxides of these elements.

##### 2. Internal supporting structures:-

Wires of gold, nickel, platinum, Kovar and Rodar, Phosphor bronze, beryllium copper, gold gallium and molybdenum.

Bases of copper Kovar & Rodar, molybdenum and nickel.

##### 3. Stems, Tubulation, and Cans :-

Leads of iron nickel alloy, Iron nickel cobalt alloy, Dumet, and molybdenum. Insulators of hard glass, multiform glass and ceramics. Tubulation of copper (including oxygen-free copper), Kovar and Rodar and nickel.

Cans of steel. Kovar and Rodar, Copper and Nickel Silver.

##### 4. Tools, jigs, Containers etc.

Teflon, Polyethylene, Polystyrene, Nylon, Graphite, fused quartz, stainless steel, nickel, Inconel platinum and gold.

##### 5. Solders and brazes :-

Solders of lead tin, lead tin doped with antimony, indium or gold and many others.

Gold Copper brazes.

##### 6. Miscellaneous:

Potting Compounds, Casting resins, Organic finishes, Silicone oils.



#### 4.8.5 CHEMICAL PROCESSING OPERATION & TECHNIQUES

1. Furnace Operations
  - a. Oxidation
  - b. Reduction
  - c. Annealing
  - d. Decarburization.
  - e. Alloying
  - f. Diffusion
  - g. Soldering, brazing, gold bonding.
  - h. Vacuum bakeout.
2. Contamination Control.
  - a. Removal of physical Contaminants : dirt, dust, fibres, oils, greases, water.
  - b. Removal of Water soluble Contaminants: Salts, Plating residues, etching residues.
  - c. Test for Cleanliness.
  - d. Storage of clean parts and Assemblies.
3. Etching of Semiconductor Material.
  - a. Preferential Etching: To locate crystal planes, expose dislocation, etch pits etc.
  - b. Non preferential Etching: To remove damaged material due to cutting and polishing.
    - To control thickness.
    - To remove Contaminants and junction shorting materials.

Etching of piece parts:

  - a. Oxide removal.
  - b. Chemical polishing.
  - c. Electro polishing.
4. Electroplating:-
  - a. Piece parts and Assemblies.
  - b. Semiconductor materials.

Chemical Plating:-

  - a. Piece parts and Assemblies.
  - b. Semiconductor materials.

**Contamination Control:** Physical Contaminants such as lint, dust, fibres, greases, Oils and waxes have been removed by blowing with compressed gauges and by organic solvent degreasing. Water soluble contaminants such as salts, acid, plating solution residues and etching, residues have been removed by the use of warm tap water, a wetting agent and ultrasonics.

**Plating:** One of the prominent Chemical procedures in transistor fabrication is the deposition of certain metals over base metals, principally by electroplating. It is done:

1. For protection of portions of assemblies during etching of the semiconductor.
2. For improved solder ability.
3. For gold alloying to a semiconductor material and
4. For Corrosion resistance such as salt spray corrosion on military devices.

**Etching and Surface Treatment of Transistor:** The process of etching, washing, drying, surface treatment and impregnation all fall into the domain of surface chemistry. Each has its own subtleties and unique contribution to transistor performance, although often the effect of one treatment may be dependent on the success of one or all of the prior steps. Transistor processing will here be discussed in chronological order.

Three principles appear basic to successful etching. It is necessary to remove any high conductivity layer which would tend to shunt the junction; Cleaner saturation current characteristic can be obtained by minimizing contamination; finally, formation of an oxide layer on the germanium surface appears important in achieving surface neutralization. In a sense, etching serves as a remedy for sins of commission or omission in transistor design and fabrication. A suitably designed and fabricated transistor would require only those surface treatment necessary, to establish controlling and permanent surface layers.

**Pre-attachment etching:** In some alloy transistor process the transistor element is etched after alloying and before all contacts are attached. This etching operation serves to remove oxides or converted surface layer which might inhibit the formation of the subsequent ohmic base connection. Some of the junction alloying material adjacent to the semiconductor must be removed, so that the periphery of the regrown region becomes more accessible to subsequent etches. The n type dope usually used for n-p-n transistors has

has high vapour pressure and a certain amount of solid state diffusion from the vapour phase may occur. The pre-attachment cleaning etch removes the resultant high conductivity surface layer which may be found on the base metal. **Kirk**

**Final etching:** Final etching is often carried out after contact attachments have been completed. This is necessary because most base and lead attachment techniques involve heating, which remelts the alloy material and oxidizes <sup>the active surfaces.</sup> The function of the etch is to remove any damaged material from the active portion of the device and have a surface which contributes, in a controlled fashion, to the transistor performance. In achieving the former, the final etch must remove any alloy material to expose the regrowth, remove the peripheral degenerate or near degenerate regrown germanium, and keep in solution any metallic salts which might precipitate on the active region of the device.

**Washing:** Ionic, solid, material which is held to the semiconductor surface can affect the surface potential through this, the device properties. In addition, such material often reacts directly with the semiconductor or with the surrounding medium, especially at high temperature to the detriment of device stability. If material is absorbed in a thick oxide layer or chemisorbed to the oxide, even prolonged washing in high purity water may not remove it. There is even some evidence that prolonged washing is detrimental to alloy p-n junction saturation current characteristics.

#### **Drying:**

**Drying:** Transistors which are difficult to dry usually have been subjected to those etches which tend to oxidize rapidly or heavily. Electro etched units or units etched in hydro-fluoric-nitric acid mixtures are more easily dried. The results from the drying experiments also indicate the presence of a layer on the germanium surface which is quite dependent on its mode and rate of formation. Differences in the surface layer, in turn, are reflected in the transistor characteristics.

Mounting process must minimize damage to the element or contamination to its surface. The stress condition occurring within the semiconductor due to mounting of the transistor elements is of prime importance in device structural design. Residual stress particularly those placing the semiconductor in tension, must be eliminated by proper structural design if the device is to have a high order of mechanical reliability. The mass of structure supported by the semiconductor should be minimized.

The attachment techniques used most frequently are processes involving the alloying or soldering of metal piece parts or piece part coatings to the electrodes or contact of the transistor elements. For these one must select metals whose alloying properties

are not critically dependent on temperature, time or the amount of metal present. To minimize residual tensile stress in the semiconductor, the thermal expansion of the base electrode piece-part and the semiconductor ~~and the semiconductor~~ wafer must be similar. Of the material used most frequently in semiconductor fabrication, the coefficient of thermal expansion of molybdenum and various ceramics match most closely that for germanium. The connection to the base electrode must have essentially *lie* characteristics. A suitable doping element i.e. antimony or gallium may be added to the metal of the base contact to prevent the formation of a rectifying junction at this contact.

**Evaporated Contacts :** Vacuum deposition of metals on the clean semiconductor surface is frequently used to apply injecting and *lie* contacts. By using carefully machined masks an excellent contact control of shape and area of the contact is possible.

**Encapsulation:** The device encapsulation process must accomplish three design objectives. The 1st requirement is concerned with protection of the mounted transistor element both from mechanical damage and from changes in the internal environment. Second, the encapsulation design must provide external terminations and means for mounting the finished transistor consistent with the needs of device applications. Finally, the power dissipation requirements on the transistor influence the encapsulation design. The satisfactory operation at elevated temperatures of all germanium alloy junction transistors depends, in part, upon the piece part surface area, mass, and materials used in the transistor encapsulation and the provisions made for thermally connecting the completed device with its environment. The seals around the external leads and between the header and envelope are of major significance in the maintenance of the internal environment of the device, because they determine the leak rate into and out of the structure.

#### 4.8.6. General results, Device characteristics :-

Results pertaining to specific design objectives have been presented, and certain process stressed to illustrate principles involved in process control. Now parts of the design theory will be presented in order to relate the theoretically predicted device parameters to those achieved in practical manufacturing process. The parameter is selected to illustrate the general applicability of the design theory to all alloy transistor types. We shall use an engineering approach and make simplifying assumptions when required.

The theoretical current through a p-n junction is given by the following expression

$$I = I_s (e^{qV/KT} - 1) \quad (3.57)$$

Where  $V$  is positive for forward current. The equation contains a "saturation current", which is determined by several material parameters (11)

$$I_s = A \frac{KT}{q} \frac{b}{(1+b)^2 \rho_1^2} \frac{\rho_{n1}}{L_P} + \frac{\rho_p}{L_N} \quad (3.58)$$

Equation no. (3.58) is valid only for an isolated p-n junction in which the material is uniform to a distance equal to several life paths on each side of the junctions. An equation for collector saturation current applicable to transistor geometry, assuming the collector larger than the emitter, has been derived as

$$I_{cs} = \frac{KT \rho_B b t \Pi}{q \rho_1^2 (1+b)^2} \left[ 1 + \frac{2a}{\lambda} + \frac{1(a^2 - c^2)}{2\lambda^2} \right] \quad (3.59)$$

where  $a$  = Collector radius

$c$  = emitter radius

$b$  = mobility ratio,

in the base region.

and  $\lambda = \sqrt{\frac{t D}{2 S}}$

Where  $t$  = Wafer thickness

$D$  = Diffusion constant for minority carriers in base region.

$S$  = Surface recombination Velocity.

After making the following substitutions (using consistent units) for a medium-power p-n-p alloy transistor: (36)

$a = 20.7$  mils (average value of measurement on several cross section samples).

$c = 15.0$  mils

$t = 2.5$  mils.

$\rho_B = 2.3 \Omega\text{-cm.}$

$\rho_1 = 47 \Omega\text{-cm.}$

$S = \text{Assumed } 300 \text{ cm/sec.}$

$b = 2.15$

$D_p = 46 \text{ cm}^2 \text{ sec.}$

Transistor parameters which depend upon base-layer thickness are current gain ( $h_{fb}$ ) frequency cut off  $f_{hb}$ , reach through voltage, and emitter floating potential. If one assumes perfect concentricity of parallel circular emitter and collector junction, and also close spacing between a relatively large-area collector and a small area emitter, the expression for low voltage

$$h_{fb} \text{ is } h_{fb} = \alpha \beta \gamma \quad (3.6.3)$$

Where  $\alpha$  = Intrinsic Collector efficiency  
 = 1 for alloy junction transistor for low voltage.

$$\beta = 1 - \frac{W^2}{2L_B^2} = \text{Transport efficiency}$$

and  $\gamma = \frac{1}{1 + \frac{\sigma_B W}{\sigma_E L_E}} = \text{Emitter efficiency.}$

Where  $W$  = base layer thickness

$L$  = Diffusion length for minority carrier.

$\sigma$  = Conductivity.

A small, randomly picked group of medium power high frequency p-n-p's was measured for  $h_{fb}$  and effective junction life time by Mullerd. The calculated nominal  $h_{fb}$  for those units was .999, using the following nominal values of material and structure parameters:

$$\begin{aligned} \tau_B &= 9 \mu\text{Sec} \\ W &= .62 \text{ mil} \\ \rho_B &= 2.3 \Omega\text{-cm} \\ \sigma_E L_E &= .6 \Omega^{-1} \end{aligned}$$

For low voltage and currents the frequency cut off of  $h_{fb}$  is

$$f_{hb} = \frac{1}{W^2} \text{ mc with } W \text{ in mill} \quad (3.64)$$

Since the effective base layer thickness,  $W_1$ , decreases for increasing collector bias voltage, we would expect an increase in  $f_{hb}$  as voltage is increased.

In alloy transistors, most of the collector depletion-layer widening with voltage occurs in the base region. Therefore, electrical reach-through can be simply related to the base properties

$$V_{RT} = 3.7 \times 10^{-13} N_1 W^2 \quad 3.6.5$$

Departures from the calculated level of reach- though voltages can be generally attributed to three causes

1. Material defects
2. Misorientation and
3. non-uniform wetting.

Low values of  $V_{RT}$  are caused by local alloy penetration due to defects in the  $G_e$ , since the wafer orientation was held to the  $\langle 1 : 1 : 1 \rangle$  plane  $\pm 5^\circ$

Emitter floating potential is related to the  $h_{fb}$  of the transistor by

$$V_{ERF} = \frac{KT}{q} \ln(1 + h_{fb}) \quad (3.6.6)$$

For an alloy transistor shown in fig. 3.22 expression for base resistance is given by

$$r_b = \rho_B \left[ \frac{1}{8\pi w_1} + \frac{1}{2\pi w_2} \ln\left(\frac{r_2}{r_1}\right) + \frac{1}{2\pi w_3} \ln\left(\frac{r_3}{r_2}\right) \right] \quad 3.6.8$$

$$\text{or } r_b = \frac{\rho_B}{2\pi w_3} \ln\left(\frac{r_3}{r_2}\right) \quad 3.67$$

As modulation of base layer conductance at high current densities causes the 1st term in Equip (3.66) to become negligible and the 2nd term is also neglected as the collector is open ckted during the measurement of emitter to-base forward resistance.

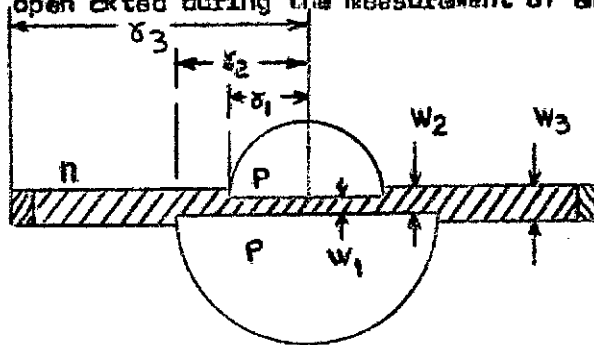
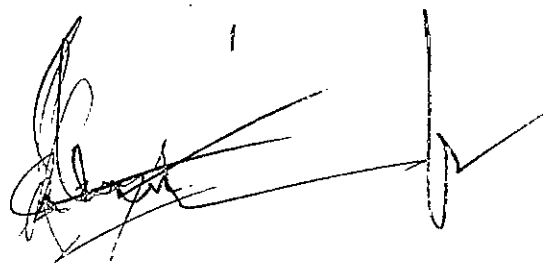

Fig. 3.22 Pictorial Representation of Symbols of Alloy Transistor.

CHAPTER IV

A handwritten signature in black ink, appearing to be 'John J. ...', written in a cursive style. The signature is located in the lower right quadrant of the page.



## FEASIBILITY STUDY OF ELECTRONIC COMPONENT MANUFACTURING PLANT

### 4.1. Introduction

The electronic industry of Bangladesh can not depend on imported components for a long time and must have a solid foundation by establishing an electronic components manufacturing complex. But before setting up of this plant, planning and costing with a detailed analysis of its requirements in labour and foreign collaboration would be necessary.

### 4.2. Description of Electronic Industries of South East Asian Countries:

A brief discussion on the development of electronic industries in certain South East Asian Countries is given <sup>to</sup> an industrialist or the Government of Bangladesh in taking a realistic approach towards the setting up of an electronic component manufacturing plant.

SINGAPORE: Its electronic industry is only about 4 years old. The fixed assets of the company were \$ 23 million. It has tremendous stride in the field of manufacturing components and some other electronic goods mainly for export. The rapid expansion of her electronic industry is shown in the table

Year	Production	(42) (Figures in million us dollars) Export.
1968	3.	n.a.
1969	n.a.	16.00
1971	110.0	59.00

HONGKONG: The electronic industry in Hongkong started in 1959. Now 25% of the components manufactured are used by the local industries. In 1972 electronic goods of local manufacture worth \$ 283.6 million were exported. Initially foreign participation in the industry played a key role. Now the industry is owned largely by the local people. The expansion of industry is shown below :

Year	TABLE 4.3.2 No. of factories	(42) No. of employees
1965	33	5,000
1970	223	32,000
1972	305	50,000

KOREA AND MALAYSIA : In both countries electronic industry started in 1966.

Export program of Korea for 1973 was \$ 300 million.

PHILLIPINES:- Today Phillipine has got 29 factories for the electronic industry. The advantage of this country is the cheapest source of labour.

JAPAN:- Japan is and only of USA in the manufacture of electronic goods. In 1969 Japan's export of electronic goods was worth \$ 2 billion and in 1970 it rose to \$ 2.4 billion.

INDIA:- In India electronic industry started in 1966.

The public owned companies are (39) :

1. Bharat Electronics Ltd. at Bangalore.
2. Hindustan Aeronautics Ltd. at Hyderabad.
3. Indian Telephone industries at Bangalore.
4. Electronic corporation of India Ltd. at Hyderabad.
5. Instrument Ltd. at Kota
6. The Indian telephone industries at Naini.
7. Bharat Electronics Ltd. at Geziabad.

In 1970- 71 total value of Electronic equipment and components manufactured in India was Rs. 1750 million. In 1965-66 the export of electronic goods of India was Rs.14.732 million and in 1969-70 it jumped to Rs. 49,661 million.

4.3 Discussion: It is estimated that for manufacturing of electronic goods worth Rs.10,000 the labour cost would be Rs.3,800 and average investment of capital per worker is approximately Rs.5000. The above facts shows that electronic industry in the South East Asian Regions of recent origin and its development is very rapid. One important characteristic of this industry is that an ever increasing demand of consumer items is created by this industry. Whether big or small, poor or rich there is increasing demand for radio sets as will be seen from the table.

TABLE 4.3.3 (33)

Name of the Country	No. of radio sets in use (1000)			Population	Per Capita national income in US \$		Radio sets in use per 1000 inhabitants.	
	1960	1968	1969		1968	1968		
Burma	115	388	399	26,980	67	1968	15	
Ceylon	354	450	500	12,240	137	68	41	
Hongkong	165	639	675	3,990	381	63	169	
India	2,148	9,275	10,035	536,984	73	68	19	
Indonesia	678	1500	na	116,000	86	68	14	(68)
Iran	935	2500	na	27892	252	68	93	(68)
Japan	12,410	25742	na	102,321	1,288	69	255	(68)
Korea	781	2,393	3,242	31,300	163	68	104	
Malaysia	303	423	na	1,581	254	66	41	(68)
Philippines	600	1,623	na	37,158	283	69	49	(68)
Ryuku Is	na	321	336	973	282	63	342	
Singapore	na	99	102	2,017	756	69	50	
Thailand	163	25,55	2762	34738	126	69	80	
Vietnam	125	1000	1,300	17,867	150	67	73	
Bangladesh	na	168	297	74,980	131	69	3.7	

The above table shows that we are the poorest possessors of radio sets although our per capital income is not the lowest. A very modest figure should have been 15 radio sets per thousand of population. For this we need 11 more radio sets per thousand of population. Thus for 75 million people we would need 8,25000 more radio sets.

In a survey carried out in the month of April, 1974 the import figures of electronic components into Bangladesh for the year 1973 are found to be as follows :-

TABLE 4.3.4

Components for radio Assembly to industries	Tk. 54.69 Lakhs
Components for radio servicing to shops	Tk. 2- 25 Lakhs.
	<hr/> Tk. 56. 94 Lakhs.

The following table shows the annual demand for radio sets and estimated demand for its component in Bangladesh.

TABLE 4.3.5 (2)

Period	Radio sets	Components Tk. in Lakhs.
1970-75	260,000	187.2
1975-80	440,000	328.8
1980-85	668,000	489.6

From the above table it appears that if the radio components are manufactured here, then a reduction of foreign exchange liability of Tk. 167.82 lakhs can be achieved annually where as capital investment of Tk. 3-10 lakhs will be required for machineries of each components. Therefore, the total capital investments for manufacturing all the parts of radio receiver shall be within Tk. 2 crores. For establishing an electronic component manufacturing plant in Bangladesh the total amount required shall be within Tk. three crores.

#### 4.4 Investment cost of an electronic component plant.

The table shows the investment cost of an electronic component manufacturing plant.

TABLE 4.3.6

Cost of land and civil construction	Tk. 85,00,000
Cost of transportation vehicles	Tk. 5,00,000
Cost of raw materials required for a year	Tk. 20,00,000
Cost of required machines	Tk. 1,00,00,000
Yearly salaries	Tk. 10,00,000
Sundry expenses	Tk. 30,00,000
	<hr/>
	Tk. 2.5 crores
Overhead expenses (20%)	Tk. .5 crores
	<hr/>
Total	Tk. 3 crores.

4.5 Conclusion: Production of electronic industry has tremendous scope for expansion. But at the same time it has bright future for export. To fully develop export possibility foreign participation has been found to be essential. Products

of foreign firms have good export market. But due to high labour costs in the development countries the foreign companies are establishing industries in developing countries where labour is abundant and cheap. Local participants are also encouraged due to employment opportunities of local people, and profit sharing in foreign exchange earning. Such mutual benefit has been the guiding factor in developing electronic industries in Bangladesh. Having very large population and educated unemployed youths Bangladesh is a very favourable position to develop electronic industries to considerable extent.

**CHAPTER -V**

## DISCUSSION

### 5.1 General

Radios have received a saturation of more than 200% in developed countries and the saturation of radios varies between 12% to 35% in the developing countries. In a survey conducted recently in the month of April, 1974 in Dacca and Savar areas shows that about 10% - 20% of our families in the villages and 60% - 70% families in the cities have got receiver sets. The result of the survey also gives an indication of the demand for radios of various bands. The result is represented graphically.

It appears from the curve that one band radio is in maximum demand in villages and 3 band radio is in maximum demand in the cities.

Interesting features of the survey are :-

1. People are interested to listen to Dacca, Calcutta and B.B.C. stations.
2. A large no. of families showed great interest in buying low cost radios.

In another survey carried in the same month, 1974 in Dacca it is found that the selling price of a one band medium wave transistorised radio of different makers ranges from Tk. 300 to Tk. 350. This is an abnormally high price for the millions who live in villages. The reasons for this high selling prices are mainly due to a high import duty and sales tax (250%), high direct and indirect labour cost (126%) for the 100% price of the components and luxurious design of the radio set. The cost per set should be brought down to the purchasing power of common people who never enjoy any fruits of modern science in this space. Thus a need for the mass production of low cost medium wave radio receiver was felt.

#### 5.1.1 TUNED RADIO FREQUENCY RECEIVER CIRCUIT

A TRF Receiver Circuit using five transistors and two filter circuits for alternative use by switch was designed and assembled with the components available in the market. Two filter circuits of 690 KC/S and 670 KC/S are made to use in the TRF with a view to listening to Dacca and Calcutta stations respectively. The no. of components were reduced as far as possible.

The broad-casting frequency of Dacca station is 690 KC/S and that of Calcutta is 670 KC/S. To tune both the stations a sharp cut off filter circuit is needed. With the

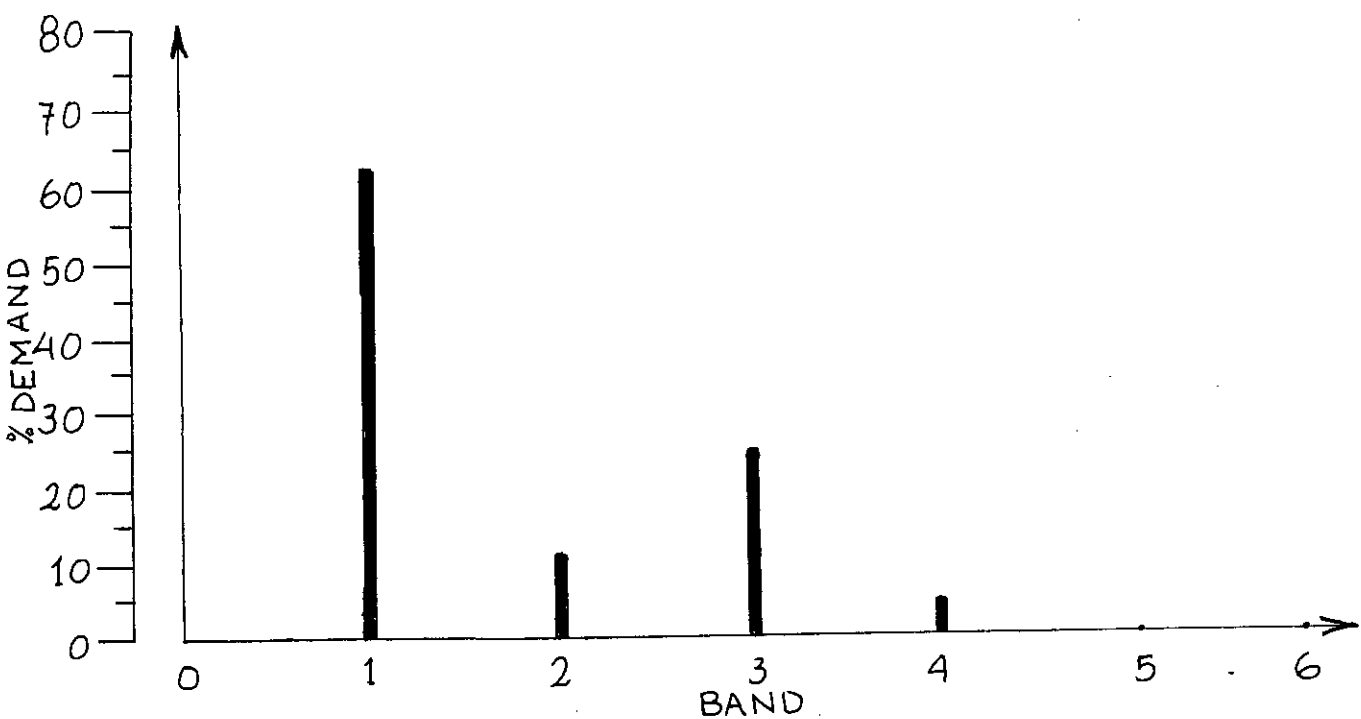

FIG-5.1 DEMAND VS NO.OF BAND RADIOS IN VILLAGES.

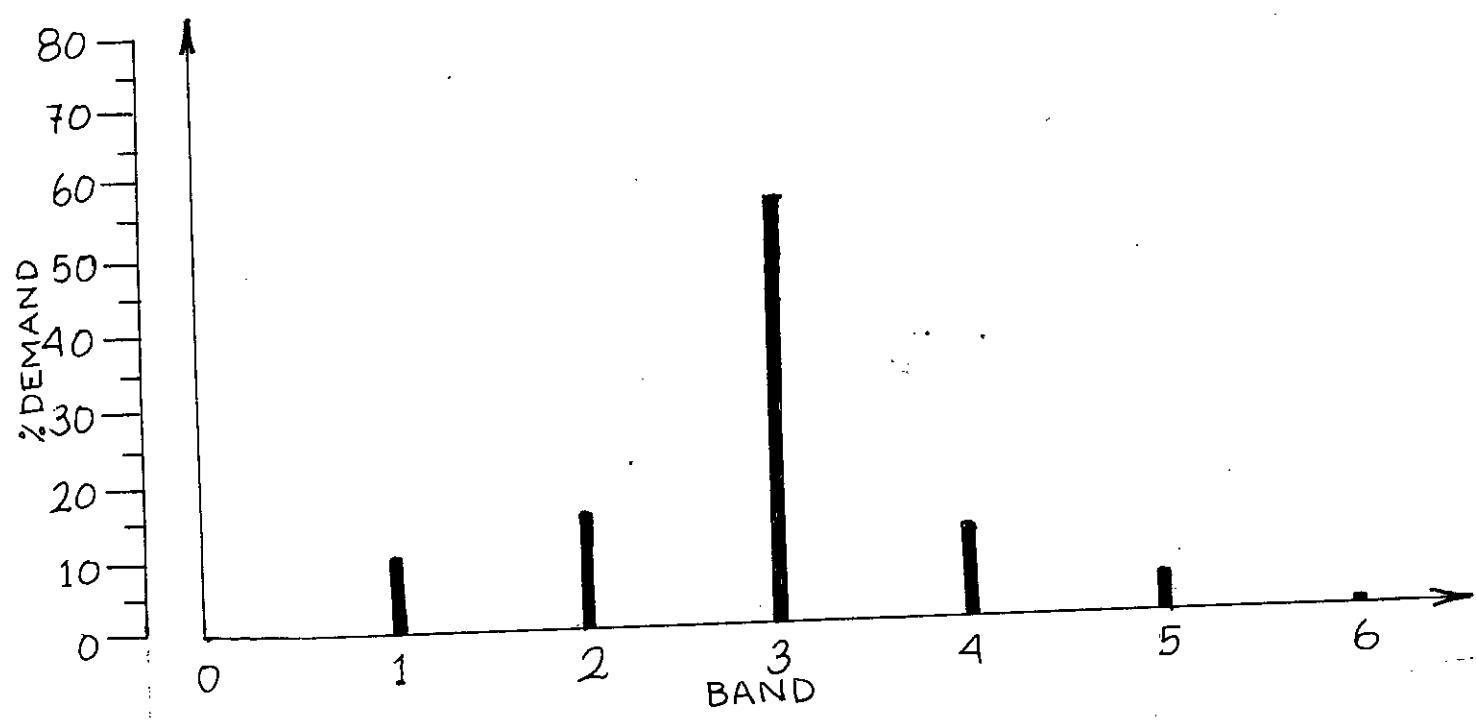

FIG-5.2 DEMAND VS NO.OF BAND RADIOS IN CITIES



available wire it has been tried to minimize the band width of the filter circuit but the band width cannot be reduced below 30 kc/s. As a result when 100 Kw medium wave Dacca Broad Casting station is in air, Calcutta station cannot be tuned in Dacca. Two filter circuits of the same frequency of 660 KC/S are made and instead of R-C coupled the two filter circuits are used. Both the stations then can be tuned but the gain of each station becomes poor.

First and 2nd Transistors are resistance coupled which give a degree of oscillation between the two tuned circuits. In the oscilloscope it is found to be 625 KC/S. So using one filter circuit of 625 kc/s the following stations can be tuned :-

Stations	Signal frequency
Dacca A	690 kc/s
Dacca B	1170 kc/s
Calcutta C	590 kc/s
Calcutta A	670 kc/s

Calcutta A can be tuned only when Dacca A is off in Dacca.

The following table shows the currents and voltages of different transistors of the TRF circuit.

TABLE 5.1

Currents and voltages of different transistors in the TRF Receiver

$V_{cc} = 6$  volts.

Transistors	Currents			Voltage		
	Base in $\mu A$	Collection in mA	Emitter in mA	$V_{eg}$ in volts	$V_{Eg}$ in volts	$V_{Bg}$ in volts
AF 115	33	1	.9	4.2	1.1	1
2SA12	39	2	1.8	5.4	1.6	1.4
2 SB56	9	1	9	5	2.1	2
2SB 156	5-20	6-15	2-5	5.9	.26	.25
2 SB 156	5-20	6-15	2-5	5.9	.26	.25

Power output = 0.625 watts.

### 5.1.2 SUPERHETRODYNE

A low cost medium wave transistorised Radio Receiver using five transistors, 2 intermediate frequency transformers and a driver transformer has been designed and assembled with the components available in the local market. The cost of the receiver was initially estimated to be about Tk. 202 in the month of April, 1974. Some of the components such as antenna coil, oscillating coil, i.f. transformers and driver transformer were made in the laboratory. In this way the price per set was brought down by about 20%.

The following table shows the biasing currents and voltages of different transistors in the superheterodyne receiver.

TABLE 5.2

Currents and voltages of different transistors in the Superheterodyne receiver.

$$V_{cc} = 6 \text{ volts.}$$

Transistors	Currents			Voltage		
	Base in mA	Collector in mA	Emitter in mA	$V_{eg}$ in volts	$V_{Eg}$ in volts	$V_{Bg}$ in volts
AF 115	35	1	.9	5.2	1.2	1.1
DC 45	40	1.1	1	5.4	1.7	1.55
25B54	10	1	.9	5	2.1	2
25B170	15 ~ 30	30 ~ 50	10 ~ 15	5.9	.4	.3
25B 17B	15 ~ 30	30 ~ 50	10 ~ 15	5.9	.4	.3

### 5.2 COST ANALYSIS

The cost per radio set has been analysed in three different ways :

- Radio set may be assembled in Bangladesh with the components purchased from local market.
- It may be assembled with the components imported directly from foreign countries.
- It may also be assembled here with the components manufactured locally through an industry.

5.2.1 COST OF THE COMPONENTS OF TRF

Components	Price of the components available in local market in Tk.	Price of the components imported directly from foreign countries in Tk.	Price of the components manufactured locally in Tk.
1. Ferrite	10.00	5.00	3.00
2. Antenna coil	1.00	.50	.25
3. Filter circuit	4.00	2.00	1.75
4. Volume control	10.00	5.00	3.00
5. Variable capacitor	14.00	7.00	5.00
6. Transistor (5)	25.00	12.00	10.00
7. Speaker	20.00	10.00	8.00
8. Input transformer	10.00	5.00	4.00
9. Output transformer	10.00	5.00	4.00
10. Electrolytic capacitor(4)	6.00	3.00	2.00
11. Resistors (11)	5.00	2.50	.66
12. Gnde	2.00	1.00	.75
13. Ceramic capacitors(5)	4.00	2.00	1.25
14. Printed circuit	20.00	10.00	5.00
15. Connecting wires	1.00	.50	.25
16. Knobs, Switch & Cabinet	30.00	15.00	10.00
	<u>172.00</u>	<u>86.00</u>	<u>58.96</u>

Assuming labour cost 70% and profit 30% the cost per set is calculated and shown below :-

TRF assembled  
with the components  
available in the  
local market.

TK.344/-

TRF assembled with  
the components imported  
directly from foreign  
countries.

Tk. 172/-

TRF assembled with  
the components manu-  
factured locally

TK. 118/-

The cost does not include the sales tax.

The following parts were made in the laboratory and Tk. 15.00 is saved approximately.

Market price

Making cost in the laboratory

Antenna coil Tk. 1.00

Tk.0.25

Filter circuit Tk. 4.00

Tk.1.75

Input-output  
transformer Tk.20.00

Tk. 8.00

TK.25.00

TK.10.00

5.2.2 COST OF THE COMPONENTS OF  
SUPERHETRODYNE

Components	PRICE OF THE COMPONENTS		
	Available in local market in Tk.	Imported directly from foreign countries in Tk.	Manufactured locally in Tk.
1. Ferrite	10.00	5.00	3.00
2. Antenna coil	1.00	.50	.25
3. Oscillating coil	5.00	1.50	1.25
4. IF transformer(3)	13.50	6.00	4.30
5. Volume control	10.00	5.00	3.00
6. Variable capacitor	14.00	7.00	5.00
7. Transistors (6)	30.00	15.00	12.00
8. Speaker	20.00	10.00	8.00
9. Input transformer	10.00	5.00	4.00
10. Output transformer	10.00	5.00	4.00
11. Electrolytic capacitor (6)	9.00	4.50	3.00
12. Ceramic capacitors(6)	5.00	2.50	1.50
13. Resistors (16)	8.00	4.00	.96
14. Thermistor (1/2)	4.00	2.00	1.50
15. Diode	2.00	1.00	.75
16. Printed circuit	20.00	10.00	5.00
17. Connecting wire	1.00	.50	.25
18. Knob, switch & cabinet	30.00	15.00	10.00
	202.50	101.00	67.96

Assuming labour cost 70% and profit 30% the cost per set has been calculated and is shown below :-

SUPERHETRODY RECEIVER ASSEMBLED WITH

The components available in the local market.	The components imported directly from foreign countries.	The components manufactured locally
--	---	--

Tk. 405

Tk.202

Tk. 136

The cost excludes the sales tax.

The following parts were made in the laboratory and Tk. 15.50 is saved approximately.

	Market price	Making cost in the laboratory.
Antenna coil	Tk. 1.00	Tk. .25
Oscillating coil	Tk. 5.00	Tk. 1.25
Input-output transformers	Tk.20.00	Tk. 8.00
IF transformer (3)	Tk.13.50	Tk. 4.50
	Tk.39.50	Tk. 14.00

The following parts are reduced from the circuit and Tk. 6.00 is further saved.

	Market price	Imported price
Transistor 1	Tk. 5.00	Tk. 2.50
IF coil 1	Tk. 4.50	Tk. 2.00
Resistor 3	Tk. 1.50	Tk. .75
Ceramic capacitor 2	Tk. 1.50	Tk. .75
	Tk.12.50	Tk. 6.00

When a driver transformer is used in place of input-output transformer Tk.15 is saved as the making cost of driver transformer is Tk. 5.

Therefore Tk. ( 15.5 + 6.00 + )5.00 ) = Tk. 36.50 is saved.

DIPLOMA IN RADIO ENGINEERING

UNIT V

CHAPTER- VI

## CONCLUSION

### 6.1 GENERAL

Two low cost transistorised radio receiver circuits have been designed and assembled. one of them is TRF (Tuned Radio Frequency) and the other one is superhetrodyne receiver. In TRF the incoming signal is tuned to the antenna and the radio frequency amplifier amplifies the signal input voltage from the antenna and impresses it upon the input to the detector through a tuning circuit of the incoming signal frequency.

In superhetrodyne receiver the incoming signal is mixed with a locally generated signal to produce an intermediate frequency which is then amplified and demodulated.

### 6.2 TUNED RADIO FREQUENCY RECEIVER

In a survey conducted recently it was observed that the people in cities are mostly interested in 3-Band radios, and the people in villages are most interested in 1-Band medium wave radios, particularly in listening to Dacca and Calcutta stations. But the present price of LB mw transistorised radio is about Tk.400/- only which is exorbitantly high and beyond the reach of the common people. In order to fulfil the demand of maximum number of people who live in villages, a TRF receiver circuit using 5 transistors and 1 filter circuit has been designed and assembled (Chapter II). In Chapter IV it has been shown that if the set is assembled with the components imported directly, the cost per set reduces to Tk. 172/- . Thus a reduction of 57% is achieved . To reduce the cost some of the components are designed and constructed. It has been shown that the price per radio set using such self made components can be brought down by about 10%. However, if an industry is set up to manufacture all the radio components, the cost per set may further be reduced by another 13% .

### 6.3 SUPERHETRODYNE :

TRF receiver requires an aerial and in the presence of local strong signal weak signals cannot be tuned. In superhetrodyne these difficulties may be overcome. In order to reduce the cost a superhetrodyne receiver using 5 transistors, 2 IF coils and a driver transformer has been designed and assembled. The no. of other radio components such as resistors capacitors has been reduced to minimum. To reduce the cost some of the components such as antenna coil, oscillating coil, IF transformer and driver transformer are designed and constructed. It has been shown that the price per radio set using such self made components can be brought down by about 20% . If the components such as ferrites,



resistors, capacitors and transistors are manufactured through an electronic industry the price per set can be reduced by about 35% .

#### 6.4 ELECTRONIC COMPONENT PLANT

A feasibility study of an electronic component plant has been made. From the cost analysis it is shown that an initial investment of Tk. 3.00 crores is required. The price of the locally made components will be one third of the price of foreign components available in the local market. As electronic components are in great demand in foreign markets also, the manufacturing plant must produce export oriented components with slight modification. The cost of plant will increase a bit but export earnings will be large and at the same time it will save our valuable foreign currency. Finally, it may be concluded that manufacturing of electronic components in Bangladesh will be highly profitable.



RECORDS SECTION  
MAY 19 1964

APPENDIX

**LIST OF THE INSTRUMENTS USED FOR RESEARCH PURPOSE  
IN THE B.U.E.T. ELECTRONICS LABORATORY.**

1. Audio Oscillator	Model 200C
2. AM/FM Modulation Meter	Type CS42
3. Audio Signal Generator	Model (hp) 205 Ag.
4. Amplifier	Model (hp) 205xAgxx 450A
5. Amplifier	G.R.C. Type 650- P1
6. Amplifier and null detector G.R.C.	Type 1231-13 Sl.no.684
7. Audio freq. micro voltmeter	Type 546 Sl. no. 2441
8. Amplifier	Model WS
9. Audio Oscillator	Type 013A Sl. no. 723
10. Bridge oscillator	Type No. 1330 A
11. Bandpass filter	Type no. 530 A Sl Ni. 619
12. Cathode ray oscillograph	Type 274A Sl. no. 3096
13. Cathode ray oscillograph	Type 303 Sl. No. 722
14. Carrier and modulation level	Sl. No. 6940 P
15. Current measuring unit	No 835 B
16. Double pulse generator	Sl no. 52160/079
17. Decade attenuator	Model no. 330 B
18. Distortion Analyser	Model no. 330 B
19. Dynograph amplifier recorder	Type 542
20. Electronic stroboscope	Type 1531
21. Electronic analogy computer	Heathkit.
22. Frequency shift keyer.	
23. Frequency meter 50 Mc/din	Mehyawsap Electric Co.
24. Granpian	
25. Impedance bridge	Heathkit
26. Low frequency oscillator	HIE
27. Low Distortion Oscillator	Type No. 1301- A
28. Lafayette calibrated Marker generator	
29. Mega pulser	
30. Minidac	6010
31. Marker generator	STSA
32. Merchant figure matic	
33. Moisture meter	
34. Network analyser	

35. Oscilloscope	Cenco	Catalog No. 71558- 017
36. Output power meter		Type no. 583A Sl No 4970
37. Oscilloscope		Knight
38. Oscilloscope	G.E.C.	Type ST-2A
39. Oscilloscope	Heat kit	Sl no. 1633668
40. Oscillator		Type 1302 Sl no. 349
41. Opornik Dekadowy type		
42. Pulse generator		Type No.869 A
43. Power amplifier		1233 A
44. Power stat.		
45. Pulse analyser		Type no. 101 Sl No. 154
46. Power supply G.E.C.		model 4 ST 1A 1
47. Power supply Harrison.		6226 B
48. Power supply model (hp)		710 A
49. Regulator L.V. power supply		Heathkit
50. Regulated power supply		Type YPD-2
51. Regulated power supply		Lambde.
52. Radio frequency head		15 to 125 Mc/5
53. Servoscope		
54. Syncho ahten encator.		
55. Signal generator		
56. Solarscope		CO 1014.3
57. Sweep Generator		Type Sl 4A
58. Squara Wave generator		Model 210 A
59. Test Oscillator model (hp)		650 A
60. Time measurement Counter technometer		M1157
61. Transmitter and Receiver output test set T.F. 1065 A		
62. Tube tester		
63. Unit Oscillator		Type 1218 B
64. Universal bridge		TF 131B No.52055/076
65. Unit amplifier		1206A Sl No. 176
66. Valve characteristics meter		P-508

67. VTVM	Heekit	
68. VTVM	Tech model VE65	
69. VTVM	Type 1800 A SI No. 2155	
70. VTVM	Model (hp) 410B	
71. Variable inductor	Type no. 107 SI No. 5712	
72. Variac auto transformer	Type no. WSMT	
73. Variable Electronic filter.		
74. Wide range oscillator	Model (hp) 200 cp.	
75. Wave analyser	736A SI 1352	
76. Wave recorder		
77. Wave filter	T No. 830 Lowpass	
78. Wave filter	T no. 830 R Bandpass.	
79. Wide band decade amplifier	Type 500 A SI No. 263	
80. 100 watt transmitter		
81. 100 watt 7db attenuator		
82. 50c tuned ckt	Type no. 1231 PS4	SI. No. 966
83. 400-100 C tuned ckt.		
84. 5 KV ionisation tester	Type no. 732	

---

LIST OF THE INSTRUMENTS USED FOR RESEARCH PURPOSE  
IN THE B.U.E.T. MICROWAVE LABORATORY.

1. Adapter		model	x 281 A	
2. Adapter		model	H281 A	
3. Adapter		model	G 281 A	
4. Adapter		model	S 281 A	
5. Adjustable attenuator		T No.	1231 P4	Sl no. 537
6. Adjustable <del>male</del>	stub		20 cm.	
7. Adjustable <del>stub</del>	stub	874. D	50	.50 cm.
8. Adjustable	stub	874	020	20 cm
9. Adjustable	stub	1620	P1	20 cm.
10. Adapter <del>twimab</del>		95	300	200
11. Adjustable short		Model	X 2920 A	
12. Adjustable short		model	S 920 A	
13. Adjustable short		model	j 920 A	
14. Adjustable short		model	G 920 A	
15. Bolometer bridge type		No.	1631 AQ	Sl no. 128
16. Barretter mount		model	S 485 A	
17. Bolometer mount		model no.	476 A.	
18. Balun		Type	874 4 BL	
19. Co-axial filter		1 GR	50	lowpass.
	185 Mc/s,	500/Mc/s		1000 Mc/s & 2000 Mc/s
20. Coaxial to BNC male - 50				
21. Coaxial to square loop				
22. Cable terminals			50	
23. Cable terminal corner				
24. Crystal detector model x 421 A				
25. Constant impedance trombone line T no.874				
26. Constant impedance adjustable line 10 cm 874 Lk10L.				
27. Card punch 18M29				
28. Carriage model 809B Cable 50				
29. Dielectric sample holder Si No. 1202				
30. Detector mount model				

31. Directional coupler Model X 752c, G 752 A.
32. D.C. micro ammeter.
33. Dummy antenna Standard 1000 P4
34. Flanged panel connection Assembly.
35. Frequency meter X 532 A
36. Horn antenna RSC 91836 UG 19L/AP
37. Klystron RK 2 K 29, RK 2 k 22
38. L.R. line with rotatable slave- 874.
39. Moving load model X 914B, G 914 A, J 914 A.
40. Multimeter.
41. Oscilloscope (hp) model 120
42. PRD 377 A SL no. 278
43. PAD Model no. 802 H3
44. Power meter microwave model 430 C 812A.
45. Power Supply model 715 A.
46. Phase shifter model no. 885 A.
47. Standard signal generator type 1021 A.
48. S.H.F. Signal generator model 630 A & model 618 B.
49. Slide screw tuner model X 870 A, G 870 A  
S 870 A J 870 A.
50. Slotted line type 874 LBA
51. Standing wave indicator model no. 415 No. 415 B.
52. Slotted section model , G 810B, j 810B, H 810 B.
53. Travelling wave indicator amplifier model (hp) 492 A.
54. Thermistor mount model no. X 487B 100 & 477 B 200
55. UHF Signal generator 616 B.
56. U.H.F. Admittance meter T No. 1602
57. Unit oscillator T No. 1209- A Sl no. 278  
1208-A " 254  
1208- C " 4391  
1215-C " 5714  
1218 -B " 895

- 58. Unit IF amplifier           Type no. 1216 A
- 59. Unit Klystron oscillator   Type no. 1220-A
- 60. Unit power supply           T no. 1203- A
- ~~61. Unit power supply~~        1203- A 8Q 18
- 61. Unit Regulated power supply T No. 1201 CQ18
- 62. Voltmeter indicator         T No. 874- V, SI No. 169
- 63. Variable attenuator model X 375 A & model X 302 A.
- 64. Variar   X - 13 model no.
- 65. Variable air capacitor type 1602- P03 SI 2939.
- 66. Voltage divider
- 67. Wave line, small size, medium size and big size.



TABLE 7.1 (App)

## Characteristics of Copper Conductor SWG.

S.W.G.	Dia of Conductor (in)	Area of Conductor Sq. inch	Resistance at 15°C ohms/yard	Current at 1000 A per sq.inch.
14	.080	.005027	.0004776	5.03
16	.064	.003317	.0007463	3.22
18	.048	.001610	.07327	1.81
20	.036	.001018	.02359	1.02
22	.028	.0006158	.03899	.62
24	.022	.0003801	.06316	.38
26	.018	.0002545	.09425	.255
28	.0148	.0001720	.13955	.172
30	.0124	.0001208	.1988	.121
32	.0108	.0000916	.2621	.092
34	.0092	.0000665	.3612	.067
36	.0076	.0000454	.5292	.045
38	.0060	.0000283	.8491	.0283
40	.0048	.0000181	1.327	.0181
42	.0040	.0000126	1.911	.0126
44	.0032	.0000080	2.985	.0080
46	.0024	.0000045	5.307	.0045

## BIBLIOGRAPHY

1. M. Gaziuddin,  
Design, Fabrication and Development of Electronic  
Equipment and Components in Bangladesh.
2. Gibb- Ewbank Industrial Consultants.  
Economic and Engineering feasibility study for the  
manufacture of Electronic Equipment  
Market Survey E.P.I.D.C. 1971.
3. Macfadyen K.A.  
Small transformer and inductors.
4. John S. Corning  
Transistor ckt. analysis and design.
5. Welby V.G.  
The theory and design of inductance coil.
6. Sturley K.R.  
Radio Receiver Design.
7. Jans. F. Gibbons  
Semiconductor Electronics.
8. Gohoo  
Theory and Application of Ferrite.
9. Dummer G.W.A.  
Fixed Resistor: Radio and Electronic component Vol. 1
10. Von Hippel  
Dielectric materials and Applications.
11. O. Van Norstrand  
Transistor Technology Vol II
12. W. Shockley  
Electrons and holes in semiconductor
13. Angelo  
Electronic circuits.
14. Fitchen  
Transistor ckt. analysis and design.
15. M.C. Carol  
Handbook of transistor circuit design
16. Mullard Technical Handbook  
Magnetic materials and components  
piezoelectric ceramics July 1972.
17. Mullard Technical Handbook  
Capacitor, Resistors July 1973.

18. Mullard      Technical Handbook.  
Reference Manual of Transistor Circuit 1960.
19. Mullard      Technical Handbook.  
Equivalent circuit for Junction transistor for  
RF and IF amplifier.
20. Hitachi      Transistor manual.
21. ELMAC        Transistor Manual.
22. Snetting E.C.  
Soft ferrites properties and application 1969.
23. pjm vol. Gussen  
Philips application note.  
Electronic components and material.
24. Journal of Applied Physics      April 1959.
25. IEE paper no. 2988 E
26. JAED (Japan)    No. 1      .      1972
27. JAEV (Japan)    No.2      1972
28. JAEU (Japan)    No. 3      1972
29. JAEU (Japan)    No. 4      1972
30. AEU (Japan)    No.1      1973
31. Electronics (USA) Jan.4, 1971.
32. Electronics (USA) Sept. 14, 1970.
33. UN Statistical Year book      1970.
34. Statistical Digest of Bangladesh, No. 8, 1972.  
Private communications:
35. Dr. D.E. Morris, Director Moris Electronics Pvt Ltd. India.
36. Mr. IT Mirchandani, Mng. Director, Semiconductor Electronics, India.
37. Mr. R.D. Bhargaba, Director ferrite manufacturing Co. Pvt. ltd. India.
38. Shri Shree Ram Tapana.    Mng. Director  
Permanent Magnet Ltd., India.
39. Mr. Hardiker,                  Rescon Manufacturing Co. pvt. ltd., India.
40. National Research Development Co, of India.
41. Baroda Electronics Ltd., India.
42. Shah Fazlur Rahman,          Cheixmen Applied Physics  
Dacca University, Dacca.

