

SECTION - A

There are **FOUR** questions in this section. Answer any **THREE**.

Symbols have their usual meaning.

1. (a) With a neat sketch of a plate element, derive the three differential equations of equilibrium for the problems of thin plate bending. (17)
- (b) Give the physical and mathematical interpretation of the following end conditions applied to thin plates: (18)
 - (i) Simply-supported end
 - (ii) Free end.

Also, give the necessary boundary conditions for the solution of a cantilever plate.
2. (a) With a step-by-step procedure describe the Navier's classical solution for obtaining the lateral deflection of a simply-supported rectangular plate. (17)
- (b) For a simply-supported rectangular plate ($a \times b \times h$) subjected to a uniformly distributed loading of intensity q_0 , determine the following: (18)
 - (i) maximum lateral deflection
 - (ii) maximum bending moments
3. (a) Distinguish the concept of 'Strain Energy' and 'Complementary Energy'. (17)
- A simply-supported beam of length l is loaded with a point load P at a distance a from one end. Assuming that the beam has constant cross-section with moment of inertia I and elastic modulus E , find the deflection of the beam under the load using complementary energy method. (18)
- (b)

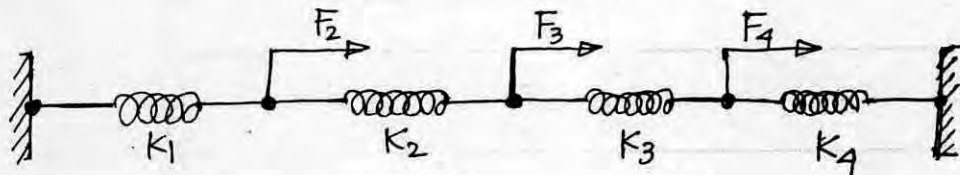

Figure for Q.3(b)

Determine the overall load-displacement matrix equation for the spring system as shown in Figure for Q. 3(b) using

- (i) Potential energy method, (ii) Equilibrium of joints method

Contd P/2

ME 441/ME

4. (a) Mathematically show that both the governing equation and boundary conditions related to the problem of beams are based on the condition of equilibrium. (20)
- (b) Find an integral expression of total potential energy for the cantilever beam-column shown in Fig. for Q 4(b). (15)

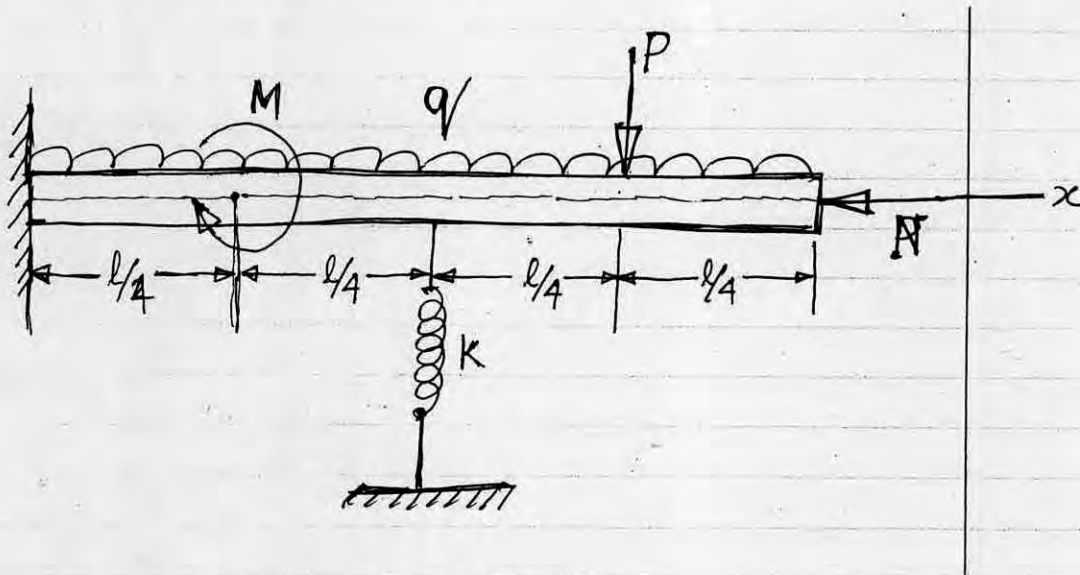

Figure for Q4(b)

SECTION - B

There are **FOUR** questions in this section. Answer any **THREE**.

5. (a) The stress field within an elastic body is given by (15)

$$\begin{aligned} \sigma_{xx} &= (50x^3 + 2y) \text{ psi} \\ \sigma_{yy} &= (40x^3 + 500) \text{ psi} \\ \sigma_{zz} &= (60y^2 + 30z^3) \text{ psi} \\ \tau_{xy} &= (100z + 80y^2) \text{ psi} \\ \tau_{yz} &= 0 \\ \tau_{zx} &= (xz^3 + 50x^2y) \text{ psi} \end{aligned}$$

Taking $E = 30 \times 10^6 \text{ psi}$ and $\mu = 0.25$,

- i) Calculate the state of strain at a point (2,2,1) within the body.
- ii) Find the body force distributions required to maintain equilibrium. Find also the components of body force at point (2,1,1).
- (b) Justify the suitability of the following stress function for the solution of the problem shown in Figure 5(b) (20)

$$\phi = \frac{P}{4a^3L} \left[\frac{x^3y^3}{6} - \frac{xy^5}{10} - \frac{a^2x^3y}{2} + \left(\frac{a^2}{5} - \frac{L^2}{6} \right) xy^3 + \left(\frac{a^2L^2}{2} - \frac{a^4}{10} \right) xy - \frac{a^3x^3}{3} \right]$$

ME 441/ME

Contd... Q. No. 5(b)

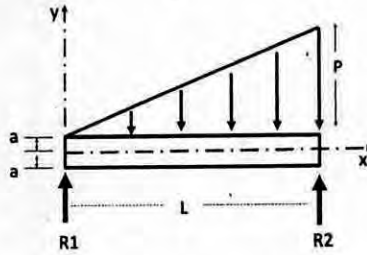

Figure for 5(b)

6. (a) Derive the Navier's equations of equilibrium for a differential cubic element. (15)

(b) An aluminum ($E = 70 \text{ GPa}$, and $\nu = 0.25$) beam is loaded by a force P and moment M at the free end as shown in the Figure 6(b). Two strain gauges at 30° to the longitudinal axis recorded the strains given. Determine the applied force P and applied moment M . (20)

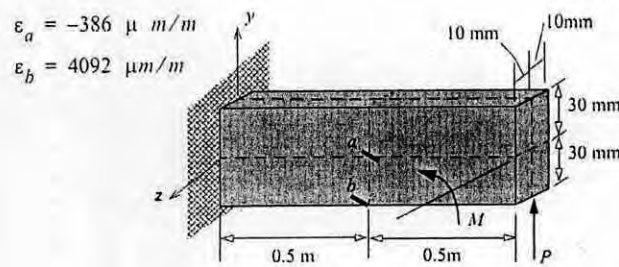

Figure 6(b)

7. (a) Given the stress function $\phi = (x, y) = Axy^4 + Bx^3y^2$. (15)

Determine the relation between the constants involved in the function so that this function is a valid stress function for 2-D stress analysis with no body forces.

(b) A function $\phi = (x, y) = Ax^2 + Bxy + Cy^2$ is given. Can this function describe the state of plane stress? If yes, show the loading conditions required to produce the state of stresses on a 2-D rectangular solid body. (20)

8. (a) A cantilever beam of length L , rectangular cross-section of height $2C$ and unit width is subjected to a concentrated load P at the free end. Obtain the solution of stresses in the beam using the stress function $\phi = axy + bxy^3$. Here a and b are unknown constants. Compare the obtained solutions with those of strength of materials. (15)

(b) Derive the torque-stress function relation for torsional problems. Also derive the expression for torsional rigidity. (20)

SECTION – A

There are **FOUR** questions in this section. Answer any **THREE**.

1. (a) A point sound source radiates power at a frequency of 1.2 kHz. At a distance of 7 m from the source SPL is 75 dB. Assuming freely progressive sinusoidal wave calculate: (16)
 - (i) acoustic power of the source (ii) I , X , U and \bar{e} at a distance of 7 m from the source. Acoustic impedance of air = 406 Rayls.
 - (b) What are the sources of noise in an HVAC system? With sketches, describe how pipe noise is attenuated in an HVAC system. (10)
 - (c) Describe the working principle of a reactive silencer. (9)

2. (a) With a sketch describe the characteristics of a standard acoustic board. (12)
 The STL of an acoustic board is 20 dB. Calculate its acoustic impedance.
 - (b) Distinguish between noise and mechanical vibration. (10)
 With neat sketches cite a practical example to establish the fact that noise and mechanical vibration are mutually convertible.
 - (c) List five adverse effects of noise. (5)
 - (d) Briefly describe how 'cooling fan noise' of a diesel generator set can be minimized. (8)

3. (a) Briefly describe the working principle of a dynamic microphone. (10)
 - (b) Describe how a sound measuring system works. (11)
 - (c) An observer receives sound at different frequencies from two sources 'A' and 'B'. When both 'A' and 'B' are on, the resultant SIL is 85 dB. When 'A' is on but 'B' is off the SIL is 80 dB. Calculate SIL when 'A' is off and 'B' is on. (14)

4. (a) A heavy duty pump needs to be installed. There must be pipe lines, electric cable and drain pipes etc. as far as noise and vibration control is concerned, describe the standard practice to install the pump with neat sketches. (15)
 - (b) Define following terms: (4)
 - (i) Reverberant sound field (ii) Directional properties of a real sound source.

ME 445/ME

Contd... Q. No. 4

(c) List requirements of a good acoustic space. (4)

(d) A room has dimensions 15 m × 10 m × 3 m. Take, (12)

α (ceiling and floor) = 0.25

α (walls) = 0.35

(i) Calculate reverberation time of the room for a sound of frequency 1 kHz.

(ii) A small machine of acoustic power 0.01 Watt is turned on in the room described above. Calculate SPL at a distance of 7 m from the machine if directivity factor is 4.

SECTION - B

There are **FOUR** questions in this section. Answer any **THREE**.

5. (a) A wheel and axle assembly of moment of inertia J is inclined from the vertical by an angle α as shown in Figure for Q. 5(a). Determine the frequency of oscillation due to a small unbalance weight W at a distance a from the axle. (17)

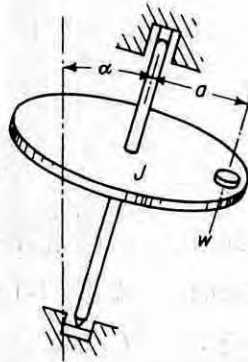

Figure for Q. 5(a)

(b) An airfoil section to be tested in a wind tunnel is supported by a linear spring k and a torsional spring K_0 as shown in Figure for Q. 5(b). If the center of gravity of the section is a distance 'e' ahead of the point of support, determine (18)

(i) the differential equations of motion of the system

(ii) an expression for natural frequency of vibration.

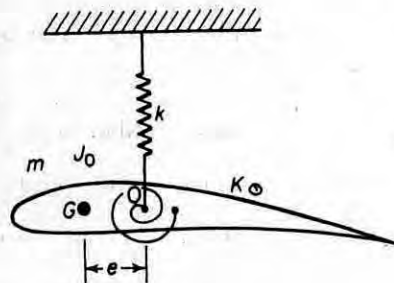

Figure for Q. 5(b)

ME 445/ME

6. (a) In a SDOFS at resonance condition the spring force is found to be 200 N for an impressed force of $50 \sin 40t$ N. Calculate the damping ratio of the system. (14)
- (b) Mention at least four causes which are responsible for whirling of a shaft. With a sketch define the terms 'synchronous whirl'. (6)
- (c) A shaft has a disc fixed with it whirls synchronously. The disc mass eccentricity is unknown but it is found that at the resonant speed the position of the disc center from the fixed reference point is 10 mm. Consider damping ratio 0.10. Calculate the position of the disc center from the fixed reference point and the corresponding phase angle for half the resonant speed. (15)
7. (a) For a SDOF system, having harmonically excited vibrations, following data are given: (18)
- $m = 200$ kg, $k = 2$ MN/m, damping ratio = 0.5.
- Draw the system, mechanical impedance diagram and write the governing equation. Find magnitude of the impressed force if $x = 0.01$ m at $\omega = 600$ rpm. Next, find the transmitted force. Also draw TR versus speed ratio β curve to show where vibration isolation is possible.
- (b) (i) A machine is installed with vibration isolators. After starting it is found to vibrate vigorously when run at operating speed. With sketches and equations briefly justify what should be done to make vibration amplitude of the machine absolutely zero at operating speed. (10)
- (ii) An engine weighing 12 kg runs at 4000 rpm (incidentally equal to resonant frequency). A tuned linear vibration absorber weighing 2 kg, is attached to it. Find magnitude of the impressed force if absorber's amplitude is 0.01 m. (7)
8. (a) A simple beam of mass M carries a concentrated load P at the middle of the span. Using Dunkerley's method, determine the natural frequency of transverse vibration of the beam. Assume the beam is uniform in cross-section. (15)
- (b) With a sketch and equation describe the working principle of a velometer. (10)
- (c) With sketches and equations distinguish between the working principle of a Lanchester damper and a Houdaille damper. (10)
-

SECTION – A

There are **FOUR** questions in this section. Answer any **THREE**.

Symbols indicate their usual meaning. Assume reasonable value for any missing data.

1. (a) For a second order system, find the condition for minimum time to attain steady state condition. (5)

- (b) Consider a unity feedback system with the open-loop transfer function: (30)

$$G(s) = \frac{K}{s(s+1)(s+2)}$$

Sketch root locus of the closed-loop system when K varies from 0 to ∞ . For what values of K will the system be unstable?

2. (a) Explain sensitivity of a control system. (5)

- (b) Calculate the error constants and determine e_{ss} for a unit step, ramp and parabolic input functions of the following non-unity feedback system: (18)

$$G(s) = \frac{1}{s(s+12)}; \quad H(s) = \frac{5(s+1)}{s+5}$$

- (c) Derive the response of a first order system under sinusoidal input. Write down the expressions for amplitude ratio, phase angle and time delay. (12)

3. (a) Define gain margin and phase margin and describe how they are related to the stability of a control system. (10)

- (b) Plot the asymptotic attenuation and phase angle diagram for an open-loop transfer function: (25)

$$G(s) = \frac{25(s+2)}{s^2 + 10.5s + 5}$$

4. Figure shown below is of an electromechanical positioning system. (35)

(i) Draw the block diagrams for the system using derivative feedback.

(ii) Derive the closed-loop transfer function.

(iii) Show the system damping ratio.

ME 461/ME

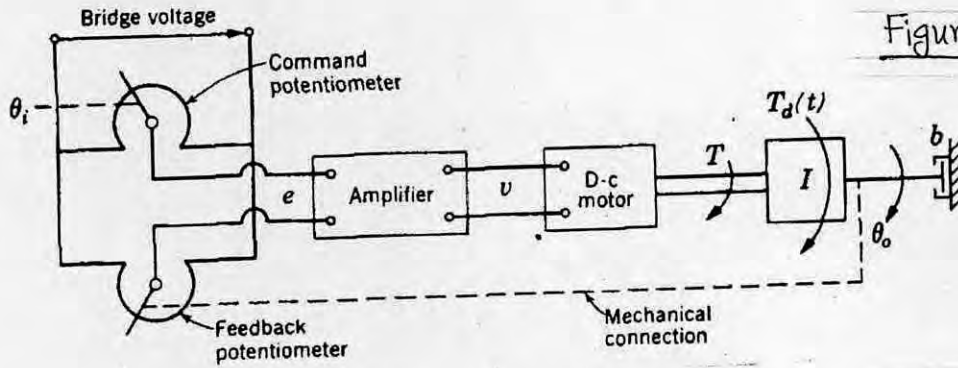

Figure for Q.No. (4)

SECTION - B

There are **FOUR** questions in this section. Answer any **THREE**.

- 5. (a) Explain the working principle of a three-position controller. (10)
- (b) Describe the dynamic behavior of a PD controller with appropriate diagrams. (10)
- (c) Consider the control system shown in Figure 5(c) in which a PID controller is used to control the system. The PID controller has the transfer function (15)

$$G_c(s) = K_p \left(1 + \frac{1}{T_i s} + T_d s \right)$$

Determine the values of parameters K_p , T_i , and T_d using a Ziegler-Nichols tuning rule. Then obtain a unit-step response curve and check to see if the designed system exhibits approximately 25% maximum overshoot.

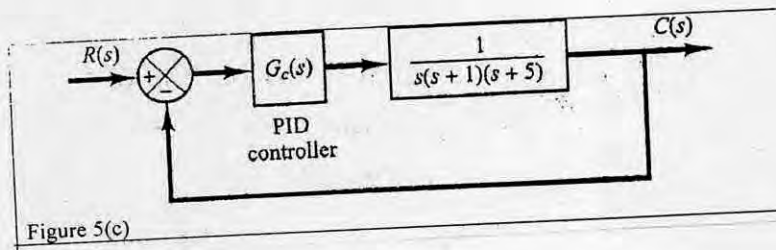

- 6. (a) For the system shown below, determine the values of gain K and velocity feedback constant K_h so that the maximum overshoot in the unit step response is 0.2 and the peak time is 1 sec. With these values of K and K_h , obtain the rise time and settling time. Assume that $J = 1 \text{ kg-m}^2$ and $B = 1 \text{ N-m/rad/sec}$. (15)

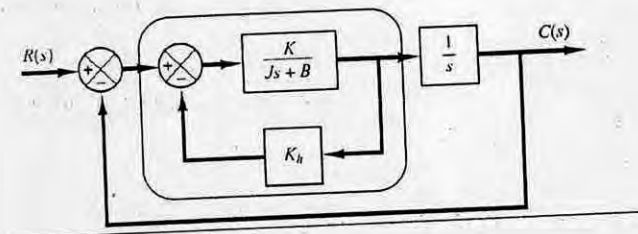

ME 461/ME

(b) Reduce the system shown in Figure 6(b) to a single transfer function.

(20)

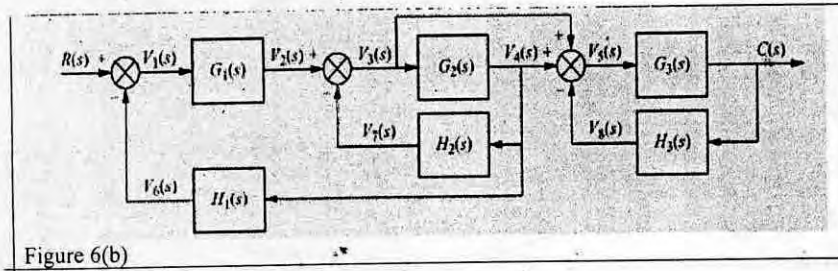

Figure 6(b)

7. (a) Find the transfer function $G(s)$ of the following differential equation:

(15)

$$\frac{dc}{dt} + 2c = r$$

Using $G(s)$, find the response $c(t)$ to an input $r(t) = u(t)$, a unit step, assuming zero initial condition.

(b) Obtain the transfer function $E_0(s)/E_1(s)$ of the electrical circuit shown in Figure 7(b).

(20)

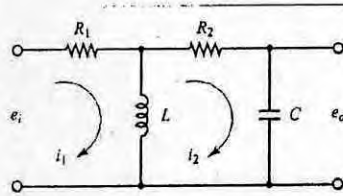

Figure 7(b)

8. (a) Explain the analogy between the building blocks of hydraulic and electrical systems.

(10)

(b) Develop the block diagram of an armature controlled dc motor shown in the Figure below.

(25)

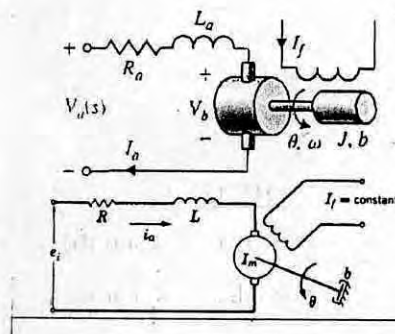

SECTION – AThere are **FOUR** questions in this section. Answer any **THREE**.

1. (a) What do you understand by formative capacity? Show that the maximum relative loss of the formative capacity remains constant for geometric progression series. (10)
(b) A lathe is to be designed for machining workpieces of 300-500 mm diameter. The permissible cutting speed for machining is 500-3300 m/min. Now design a speed box having 2 stages and a geometric progression ratio of 1.41. Draw all possible structural diagrams and select the best one. Also justify your selection by showing necessary calculation. (25)
2. (a) Describe the working principle of Positive Infinitely Variable (PIV) drive with necessary sketches. (10)
(b) List the advantages of hydraulic drive. (7)
(c) Show that the kinetic energy of a gearbox is proportional to the cube of the diameter of the gear and directly proportional to its speed. (18)
3. (a) What are the advantages and disadvantages of vee slide ways? Describe some applications of it. (8)
(b) List the points that should be kept in mind during manufacturing the machine tool structure. (12)
(c) Describe the working principle of directional control valves in controlling the movement of the table of a machine tool with necessary sketches. (15)
4. (a) What is the difference between locators and clamps? Briefly describe the guidelines that should be maintained while designing locators with necessary sketches. (12)
(b) Write down the advantages of CNC machine tools. Explain briefly. (15)
(c) Describe how the Recirculating ball nut works. Why it is important in machine tool? (8)

IPE 431/ME

SECTION – B

There are **FOUR** questions in this section. Answer any **THREE**.

5. (a) How do you cut a non-standard thread in a Lathe machine? Explain briefly. (8)
- (b) Explain the roles of clutches in gear train of a lathe machine. (7)
- (c) Can a lathe machine work by only one feed rod which will provide turning and threading operations? Justify your answer. (10)
- (d) In which method of taper turning do you need to disengage the feed screw of the cross slide? Explain the process with necessary sketches. (10)
6. (a) In which case do you need differential indexing? Explain the principle of differential indexing and derive a formula for calculating the ratio of differential change gears considering number of start of Right hand worm is 'K'. (15)
- (b) Explain generating principle of gear cutting. How do you understand the motions involved in gear shaper produces involute profile in gear blank? (15)
- (c) What are the necessity of withdrawal motion in gear shaper? (5)
7. (a) What type of bearing do you prefer in spindle assembly of an engine lathe? Justify. (12)
- (b) What should be the appropriate location of the bearing in the spindle assembly for getting machining accuracy? Explain with necessary sketches. (12)
- (c) Discuss accuracy test for lathe machine and gear shaper. (11)
8. (a) Draw the schematic diagram of Wurfel-Kopp Tournator and derive an expression for transmission ratio. Here, calculate the transmission ratio for $d_1 = d_2$ and $\alpha = -10^\circ$, $a = b$. (12)
- (b) Describe the working principle of the hydrostatic slideways. Mention some advantages of using hydrostatic slideways in machine tools. (13)
- (c) Why cast iron is most widely used for machine tool structure? Describe some limitations of cast iron. (10)
-

SECTION – A

There are **FOUR** questions in this section. Answer any **THREE**.

1. (a) Classify flames. (5)
- (b) Explain the physical meanings of (15)
 - (i) Adiabatic flame temperature
 - (ii) Self ignition temperature
 - (iii) Flammability limits.

Explain the importance of the above parameters in case of SI engines. (15)
- (c) Write short notes on (15)
 - (i) Typical equilibrium products of octane combustion
 - (ii) Laminar burning velocity of air fuel mixture
 - (iii) Combustion zones in a gas-turbine combustor.

2. (a) Write a short notes on MBT timing of an SI engine. (5)
- (b) Explain the phase of combustion in typical SI engines. Briefly explain how these (15)

phases are characterized in SI engine modeling.
- (c) What is meant by 'ignition delay' in a CI engine. Explain how 'temperature' and 'time' (15)

factors of ignition delay affect knock in CI engines.

3. (a) Briefly explain the working principle of exhaust silencers. (5)
- (b) Define volumetric efficiency of an engine. Explain how the following parameters (15)

affect volumetric efficiency:

 - (i) inlet valve opening and closing
 - (ii) engine speed. (15)
- (c) Write short notes on (15)
 - (i) exhaust gas turbo charging
 - (ii) typical valve timing diagram of an SI engine
 - (iii) Similitude principle used in SI engine air-system design.

4. (a) Make brief comparison between η_i and η_b . (5)
- (b) Draw a typical PV diagram of an actual SI engine and corresponding Otto cycle. (15)

Identify the deviations and quantify these with brief explanations.
- (c) Using appropriate assumptions, estimate the brake power available from a 1000 cc (15)

SI engine. How much power should you expect from similar sized CI engines? Explain the practical reasons behind the assumptions.

SECTION - B

There are **FOUR** questions in this section. Answer any **THREE**.

Symbols have their usual meanings.

Assume reasonable values for missing data (if required).

5. (a) Discuss how internal combustion engines are classified. (10)
(b) An 11.5×12.75 cm six-cylinder two-stroke marine diesel engine delivers 170 kW at 2100 rpm. The engine burns 50.9 kg fuel per hour. The indicated engine power is 205 kW. For these conditions, calculate (i) the engine torque, (ii) bmep, (iii) bsfc, (iv) imep, (v) isfc, (vi) mechanical efficiency, (vii) friction power and (viii) the average piston speed. (25)
6. (a) Draw and explain the construction of modern IC engine piston and connecting rod including their features. (12)
(b) Name two locations within the combustion chamber of an SI engine that probably reach higher temperatures than other locations, and give reasons for your selections. (8)
(c) List various methods available for finding friction power of an engine. Discuss their relative merits and limitations. (10)
(d) Draw and explain the brake power and specific fuel consumption versus air-fuel equivalence ratio graph for an SI engine. (5)
7. (a) Discuss how GDI engines work. (10)
(b) Explain why an idling SI engine requires a rich mixture of fuel and air. How is this requirement fulfilled in a carbureted engine and in an EFI system? (10)
(c) What are the different types of nozzles used in CI engines? Discuss their relative merits and demerits. (10)
(d) Does injection into the cylinder of an SI engine start and end at crankshaft positions similar to those for a CI engine injection system? Explain. (5)
8. (a) What are the various components to be lubricated in an engine and explain how it is accomplished? (10)
(b) Discuss the two types of cooling systems of IC engines and compare them. (10)
(c) Give brief account of air pollution due to IC engines and their effects on living beings. (10)
(d) Draw and explain the percent EGR versus throttle opening curve of an IC engine. (5)
-

SECTION-A

There are **EIGHT** questions in this section. Answer any **SIX**.

The Symbols have their usual meanings.

Assume reasonable value for missing data.

1. (a) Deduce the Euler-momentum equation for a jet of water striking a series of radial curved vanes fixed radially to the rim of a rotating wheel. Also find the expression of hydraulic efficiency of the wheel. (17)
- (b) A jet of water of 30 mm diameter having a velocity of 60 m/sec strikes without shock on a series of vanes which moves in the same direction of the jet. The vanes deflect the jet through an angle of 160° . The relative velocity at the exit is reduced by 10% of that at the inlet. The windage loss on the wheel is $0.4u^2/2$ per unit mass of water. (i) Give the derivation for the velocity of blade for the maximum efficiency; (ii) Find the force and its direction acting on the blade. (18)
2. (a) Derive an expression for the number of buckets to be set on the rim of a pelton wheel. (10)
- (b) Explain the functions of a draft tube used in a hydraulic turbine. (7)
- (c) A pelton wheel is working under a head of 450 m and its overall efficiency is 80%. An electric generator is connected with wheel whose efficiency is 90% and it is generating 4000 kW. The coefficient of velocity is 0.97, speed ratio is 0.47 and the jet ratio is 10. Find the (i) flow rate, (ii) diameter of the wheel, and (iii) synchronous speed of the generator at 50 cycles/sec. (18)
3. (a) What is unit turbine? Derive the expressions for unit quantities of hydraulic turbine. (17)
- (b) An inward flow reaction turbine is supplied with 100 cumecs of water under an effective head of 150 m. The diameter at the inlet and outlet are 3.5 m and 2.5 m, respectively. If the inlet vane angle is 120° and hydraulic efficiency is 85% and the discharge is radial with a velocity of 15 m/sec, find the power developed and the speed of the runner. Also calculate the breadth ratio and the speed ratio. Assume the breadth of the runner as constant. (18)
4. (a) Distinguish between a fluid coupling and torque converter. With neat sketch describe the working principle of a torque converter. (15)

ME 421

Contd ... Q. No. 4

- (b) Explain the function of surge tank used in hydraulic turbine. (5)
- (c) A 1/7 scale model of a turbine is to be tested in the laboratory to design an actual turbine which will develop 30,000 kW under a head of 50 m running at 400 rpm. Find the speed, output power and flow rate of the model. The overall efficiency of the model is 85% and available head for the model is 10 m. (15)

SECTION-B

There are **FOUR** questions in this section. Answer any **THREE**.

The questions are of equal value

Assume reasonable data is necessary

5. (a) Explain negative slip in a reciprocating pump. Discuss the effect of variation of pressure due to acceleration of piston in a reciprocating pump.
- (b) A single acting reciprocating pump running at 60 rpm has piston of diameter 150 mm and a stroke length of 200 mm. The suction pipe diameter is 150 mm and its length is 20m. Determine the acceleration head at the beginning of the suction stroke.
6. (a) Find the percentage of work saved by fitting air vessels in a single acting reciprocating pump and a double acting reciprocating pump.
- (b) A centrifugal pump delivers 0.20 m³/s water against a head of 26 m while running at 950 rpm. The constant velocity of flow is 2.9 m/s and the vanes are curved backward at an angle of 30°. If the manometric efficiency is 77%, find the diameter and the width of the impeller at outlet.
7. (a) Explain specific speed of a centrifugal pump. Find the equation for the specific speed of a centrifugal pump.
- (b) A centrifugal pump delivers 125 l/s of water against a head of 26m and running at 1600 rpm. The outside diameter of impeller at exit is 50 mm. If the manometric efficiency is 82%, find the blade angle at outlet. Water enters the impeller radially at the inlet.
8. (a) Draw schematic diagram of a centrifugal pump and discuss its main components.
- (b) A centrifugal pump delivers 130 l/s of water at 1050 rpm. The outside diameter of impeller is 300 mm and it is 65 mm wide at exit. The blade angle at outlet is 30°. If the manometric efficiency is 86%, find the specific speed of the pump.

SECTION-AThere are **FOUR** questions in this section. Answer any **THREE**.

1. (a) What are the major applications of refrigeration system? (5)
- (b) Draw the block diagram of a vapor compression refrigeration system with sub-cooling in condenser and superheating of vapor leaving the evaporator and depict this on a p-h diagram. (10)
- (c) Calculate the power required by the two compressors in a R134a system which serves a 60 TR evaporator at -20°C and 70 TR evaporator at 0°C . The system uses two stage compression with inter-cooling and is arranged as in Fig. for Q. No. 1(c). The condensing temperature is 34°C . Also calculate the COP of the system. (20)

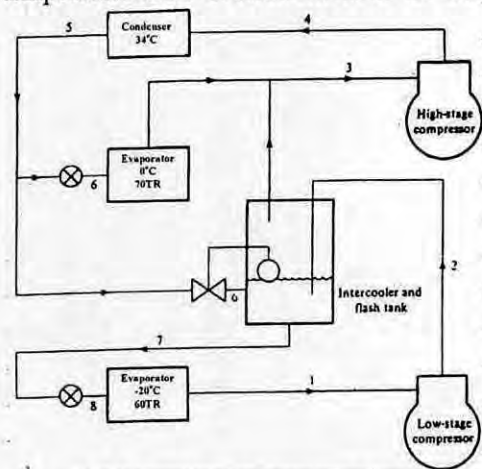

Figure for the Q. No. 1(c)

2. (a) Give the name of the factors that influence the thermal comfort for human being. (7)
- (b) Show all the Air-conditioning processes on a typical psychrometric chart. (8)
- (c) Air enters a window air conditioner at 1 atm., 35°C , and 70 percent relative humidity at a rate of $10\text{m}^3/\text{min}$, and it leaves as saturated air at 15°C . Part of the moisture in the air that condenses during the process is also removed at 15°C . Determine the rates of heat and moisture removal from the air. (20)
3. (a) A packaged air conditioner serves three rooms in an apartment. The schematic layout of the duct system, together with the volume flow rate to each room, is shown in Fig. for Q. No. 3(a). (i) Size the duct system using the equal-friction method. The duct shall be of standard round sections with diameters in increments of 25 mm. The air velocity in the first section is not to exceed 8 m/s. (ii) Estimate the static pressure in the index run of the duct network. There is a pressure drop of 25 Pa at each of the outlet grilles at E, F and G. Assume the resistance due to the fittings as one-fifth that of the duct length. (20)

ME 415

Contd ... Q. No. 6

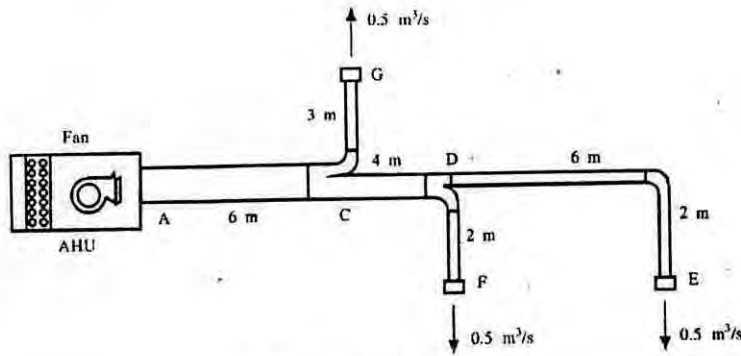

Figure for the Q. No. 3(a)

- (b) Write down some advantages and disadvantages of water fire extinguisher (5)
 - (c) Draw the typical diagram for fire protection system with ground and gravity roof tank with adequate domestic and fire reserve (according to BNBC). (10)
4. (a) What are the common safety used in a lift? (5)
- (b) Draw the schematic diagram of different arrangements of elevator doors. (10)
 - (c) For an office building, downtown, diversified use, 12 rentable floors above the lobby, each 2000 m². net. Floor-to-floor height = 3.7 m, determine a workable elevator system. (20)

SECTION-B

There are **FOUR** questions in this section. Answer any **THREE**.

5. (a) Explain how does the work of compression and power vary with the evaporating temperature in an ideal compressor with constant condensing temperature. (15)
- (b) In an absorption refrigerating system using LiBr, $T_G = 100^\circ\text{C}$, $T_E = 9^\circ\text{C}$, $T_a = 30^\circ\text{C}$, $T_C = 40^\circ\text{C}$. Estimate the values of COP for the following conditions: (20)
- i) Ideal/carnot cycle
 - ii) A real cycle if pump delivers 0.75 kg/s solution
 - iii) If a heat exchanger is inserted after the pump and water enters the generator at 50°C .
 - iv) If condensing temperature is reduced to 35°C , is there any chance of crystallization?
- The schematic diagram of the system is given in Fig. 5(b).
6. (a) Describe the Linde Liquefaction Plant for liquifying gas with neat sketch. Draw the necessary T-s diagram and explain. (17)
- (b) Briefly describe the principle of operation of a steam jet water vapour refrigerating system. What are its advantages and limitations. Draw the necessary schematic diagram. (18)

ME 415

7. (a) Describe the numbering system for Hydrocarbon, Zeotropic mixtures and Azeotropic mixtures type of refrigerants with proper examples. (17)

(b) Describe an "All-Air system with Reheat" air-conditioning system. Mention its advantages and disadvantages. (18)

8. (a) Estimate the cooling load of a class-room for 30 students at 4:00 pm for the following conditions: (35)

Location : Chittagong

Date : April 15

Floor : 8m × 8m, 3.5 m height

Roof : Type 5, without suspended, 25 mm wood, 25 mm insulation

Walls : 254 mm brick with 12.7 mm plaster on both sides.

Windings: 15% of wall area on north and west walls. 10mm clear glass, $U = 2.5 \text{ w/m}^2 \cdot ^\circ\text{C}$

Light : 30 w/m^2 . fluorescent Bulbs.

i) Assume standard indoor conditions as recommended in ASHRAE

ii) Assume no heat transfer through floor, south and east walls

iii) Assume reasonable electrical appliances.

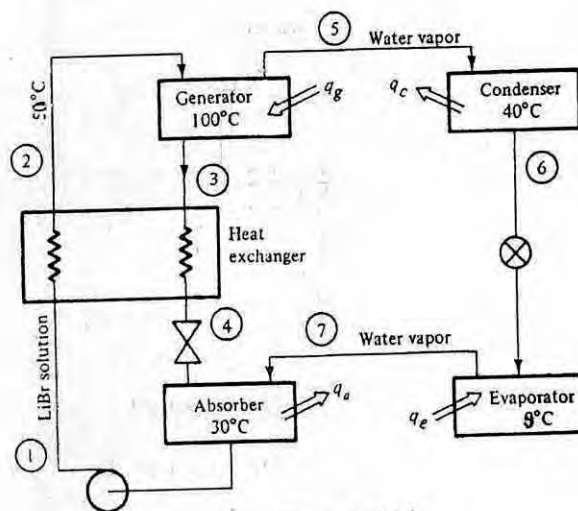

Fig. 5(b)

T1: Recommended Elevator Intervals &

Waiting Times

| Facility Type | Interval (sec) | Waiting Time* (sec) |
|--------------------------|----------------|---------------------|
| OFFICE BUILDINGS | | |
| Excellent service | 15-24 | 3-14 |
| Good service | 25-29 | 15-17 |
| Fair service | 30-39 | 18-23 |
| Poor service | 40-49 | 24-29 |
| Unacceptable service | 50+ | 30+ |
| RESIDENTIAL | | |
| Prestige apartments | 50-70 | 30-42 |
| Middle-income apartments | 60-80 | 36-48 |
| Low income apartments | 80-120 | 48-72 |
| Dormitories | 60-80 | 36-48 |
| Hotels—first quality | 30-50 | 18-30 |
| Hotels—second quality | 50-70 | 30-42 |

T2: Minimum PHC

| Facility | Percent of Population to Be Carried in 5 Minutes |
|-----------------------|--|
| OFFICE BUILDINGS | |
| Center city | 12-14 |
| Investment | 11.5-13 |
| Single-purpose | 14-16 |
| RESIDENTIAL | |
| Prestige | 5-7 |
| Other | 6-8* |
| Dormitories | 10-11 |
| Hotels—first quality | 12-15 |
| Hotels—second quality | 10-12 |

*919

T3: Car Passenger Capacity (p)

| Elevator Capacity lb (kg) | Maximum Passenger Capacity | Normal Passenger Load per Trip |
|---------------------------|----------------------------|--------------------------------|
| 2000 (907) | 12 | 10 |
| 2500 (1134) | 17 | 13 |
| 3000 (1361) | 20 | 16 |
| 3500 (1588) | 23 | 19 |
| 4000 (1814) | 28 | 22 |

C1: Average Trip Time (AVRTP)

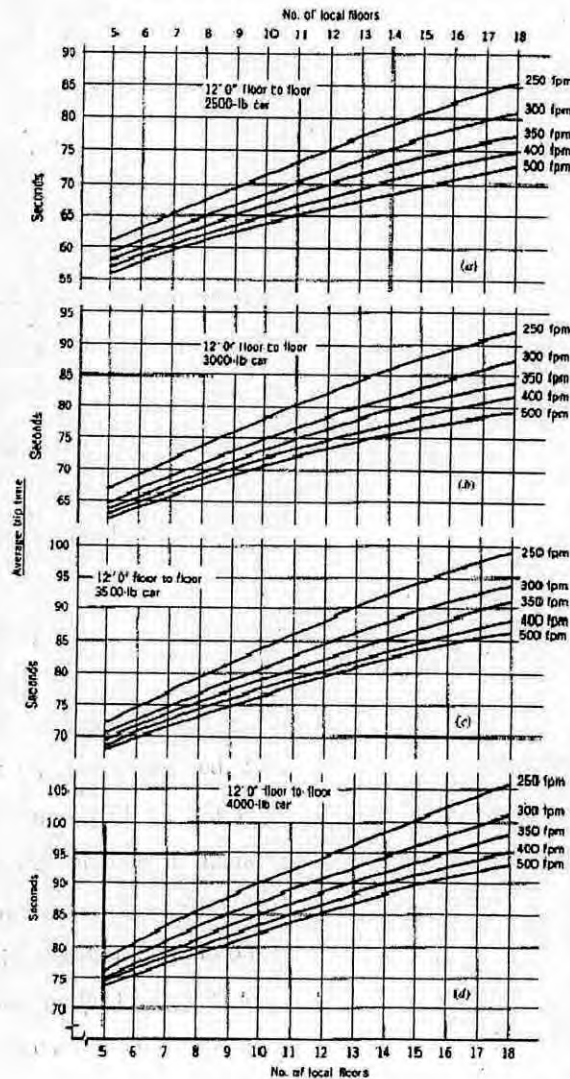

4

C2: Round Trip (RT) Time

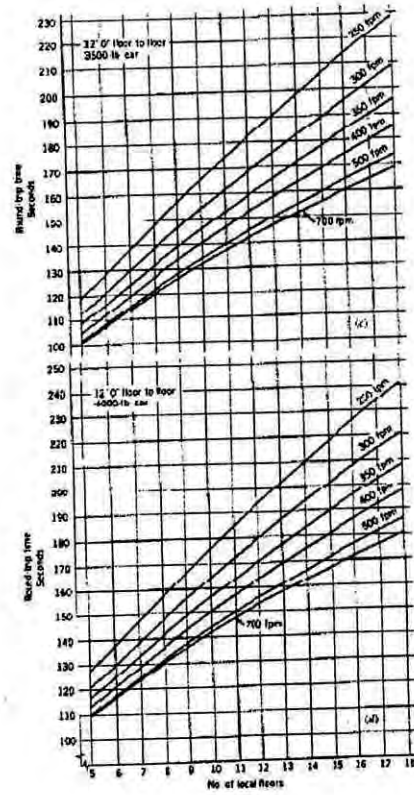
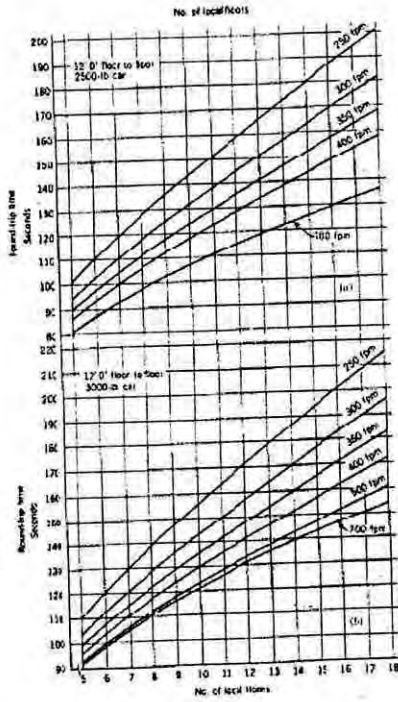

T4: Population of Typical Buildings

| Building Type | Net Area |
|--------------------------------|---|
| OFFICE BUILDINGS | FT ² PER PERSON (M ² /PERSON) |
| Diversified (multiple tenancy) | |
| Normal | 110-130 (10-12) ^a |
| Prestige | 150-250 (14-23) |
| Single tenancy | |
| Normal | 90-110 (8-10) |
| Prestige | 130-200 (12-19) |
| HOTELS | PERSONS PER SLEEPING ROOM |
| Normal use | 1.3 |
| Conventions | 1.9 |
| HOSPITALS | VISITORS AND STAFF PER BED ^b |
| General private | 3 |
| General public (large wards) | 3-4 |
| APARTMENT HOUSES | PERSONS PER EFFROOM |
| High-rental housing | 1.5 |
| Moderate-rental housing | 2.0 |
| Low-rental housing | 2.5-3.0 |

T5: Office Building Occupancy

| Building Height | Net Usable Area as Percentage of Gross Area |
|-----------------|---|
| 0-10 floors | Approximately 80% |
| 0-20 floors | Floors 1-10 approximately 75% |
| | 11-20 approximately 80% |
| 0-30 floors | Floors 1-10 approximately 70% |
| | 11-20 approximately 75% |
| | 21-30 approximately 80% |
| 0-40 floors | Floors 1-10 approximately 70% |
| | 11-20 approximately 75% |
| | 21-30 approximately 80% |
| | 31-40 approximately 85% |

6922

T6: Elevator Equipment Recommendations

| Building Type | Car Capacity ^a | | Rise | | Minimum ^b Car Speed | |
|-----------------|---|-----|-----------|--------|--------------------------------|------|
| | lb | kg | ft | m | fpm | m/s |
| Office building | { 2500 1250 } { 3000 1360 } { 3500 1600 } | | 0-125 | 0-40 | 350-400 | 2.0 |
| | | | 126-225 | 41-70 | 500-600 | 2.5 |
| | | | 226-275 | 71-85 | 700 | 3.6 |
| | | | 276-375 | 86-115 | 800 | 4.0 |
| | | | Above 375 | >115 | 1000 | 5.0 |
| Hotel | { 2500 1250 } { 3000 1360 } | | As above | | As above | |
| | | | | | | |
| Hospital | { 3500 1600 } { 4000 2000 } | | 0-60 | 0-20 | 150 | 0.63 |
| | | | 61-100 | 21-30 | 200-250 | 1.0 |
| | | | 101-125 | 31-40 | 250-300 | 1.6 |
| | | | 126-175 | 41-55 | 350-400 | 2.0 |
| | | | 176-250 | 56-75 | 500-600 | 2.5 |
| >250 | >75 | 700 | 3.6 | | | |
| Apartments | { 2000 1000 } { 2500 1250 } | | 0-75 | 0-25 | 100 | 0.63 |
| | | | 76-125 | 26-40 | 200 | 1.0 |
| | | | 126-200 | 41-60 | 250-300 | 1.6 |
| | | | >200 | >60 | 350-400 | 2.0 |
| Stores | { 3500 1600 } { 4000 2000 } { 5000 2500 } | | 0-100 | 0-30 | 200 | 1.0 |
| | | | 101-150 | 31-45 | 250-300 | 1.6 |
| | | | 151-200 | 46-60 | 350-400 | 2.0 |
| >200 | >60 | 500 | 2.5 | | | |

5