

**SECTION - A**

There are **FOUR** questions in this section. Answer any **THREE**.

1. (a) Show a logical query plan for the following query: (8)

```

SELECT title
FROM StarsIn
WHERE starName IN (
    SELECT name
    FROM MovieStar
    WHERE birthdate LIKE '%1960'
);

```
- (b) Write the steps of performing a one-pass algorithm for finding maximum value of an attribute for relation  $R$ . If the buffer size is  $M$ , what is the relationship between  $R$  and  $M$ ? Derive the relationship between  $M$  and  $R$  for a two-pass aggregate operation. (10+5+7)
- (c) Derive the total number of disk I/Os for nested loop join of two relations  $R$  and  $S$ , where number of records in  $R$  is smaller than the number of records in  $S$ . (5)
2. (a) Give an example where the Bit-map index is preferred over other indexing techniques. (5)
- (b) Discuss Linear Hashing and Extensible Hashing with examples. How do they differ from each other? (8+5)
- (c) Draw the B-tree to index the following elements: 2, 3, 5, 13, 17, 19, 23, 29, 31, 37, 41, 43 and 47. Delete two elements 31 and 43 and redraw the tree. (12+5)
3. (a) Suppose, in a B-tree, pointers are 4 bytes long, and keys are 12 bytes long. How many keys and pointers will a block of 16,384 bytes have? (5)
- (b) Find a RAID level 6 scheme with ten disks, such that it is possible to recover from the failure of any three disks simultaneously. You should use as many data disks as you can. (15)
- (c) What properties of a recovery system allow us to recover from a crash while recovering a previous crash? What are the purposes of checkpointing and nonquiescent checkpointing? (4+6)
- (d) Which two ACID properties are maintained by the Recovery Manager of a DBMS? (5)

**CSE 303**

4. (a) Why is conflict-serializability not necessary for serializability? Explain with an example. (5)  
 (b) If all transactions are well-formed and two-phase, then any legal history will be serializable – Justify the statement. (6)  
 (c) Draw the precedence graph of the following schedule? Is the schedule conflict serializable? If so, what are all equivalent serial schedules? (10)  
 $r1(A);r2(A);r3(B);w1(A);r2(C);r2(B);w2(B);w1(C)$   
 (d) Give a counter example for,  $P(S1)=P(S2) \Rightarrow S1, S2$  conflict equivalent. (4)  
 (e) Consider the following schedules of transactions T1, T2 and T3. (10)  
 $r1(A);r2(B);r3(C);w1(B);w2(C);w3(D);$   
 Now, insert shared and exclusive locks and place necessary unlocks in appropriate positions.

**SECTION – B**

There are **FOUR** questions in this section. Answer any **THREE**.

5. (a) What are the different elements of Entity-Relation Model? Briefly discuss them. (15)  
 (b) What are bags in DBMS? How are they different from sets? Give examples of union, intersection and minus operation on bags to highlight the differences. (15)  
 (c) What are the three types of relations in SQL? (5)
6. (a) What are the different policies of maintaining referential integrity? Discuss them with examples. (10)  
 (b) Convert the following ER-diagram into relations. Create three separate lists for the three isa-hierarchy conversion approaches. (15)

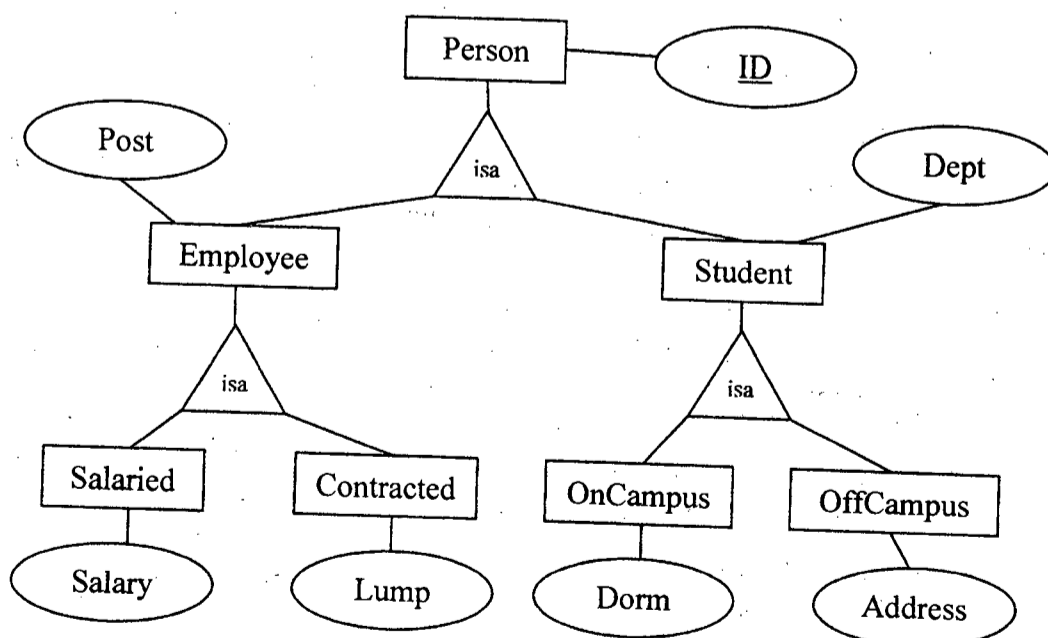

- (c) What are the differences between UNIQUE and PRIMARY KEY constraints in SQL? (5)  
 (d) Give an example of CHECK constraint and discuss why it is used. (5)

**CSE 303**

7. (a) Suppose that we have a schema  $R=(A,B,C,D)$  with functional dependencies: (15)

$B \rightarrow C$

$D \rightarrow A$

List the keys of R. Is R in BCNF? If not then convert R to BCNF.

(b) What is a weak entity set? What is the requirement of a weak entity set? (10)

(c) Discuss the subsystems that are related to query processing in a Database Management System (DBMS). (10)

8. (a) Consider the following relational schema: (25)

employee (emp\_no, name, office, age)

books (isbn, title, author, publisher)

loan (empno, isbn, date)

where the primary keys are underlined.

Answer the following queries in relational algebra:

(i) Find the names of employees who have borrowed a book published by McGraw-Hill.

(ii) Find the names and ages of employees who have borrowed all books written by Carl Hamacher.

(iii) Find the names of employees who have borrowed more than five different books published by Pearson Education.

(iv) For each publisher, find the names of employees who have borrowed more than five books of that publisher.

(v) Find the titles and authors of the books that have been borrowed by Peter Hart.

(b) What are the three anomalies in relational database schemas? Discuss them. (10)

-----

CE 314  
12+3

L-3/T-1/CSE

Date : 10/05/2014

BANGLADESH UNIVERSITY OF ENGINEERING AND TECHNOLOGY, DHAKA

L-3/T-1 B. Sc. Engineering Examinations 2012-2013

Sub : **CSE 305** (Computer Architecture)

Full Marks : 210

Time : 3 Hours

The figures in the margin indicate full marks.

USE SEPARATE SCRIPTS FOR EACH SECTION

**SECTION - A**

There are **FOUR** questions in this section. Answer any **THREE**.

1. (a) What is a jump address table? Discuss with an appropriate example how Case/Switch Statements can be implemented with a jump address table. (15)
- (b) How you can create a 32 bit constant in MIPS Assembly Language? (5)
- (c) Consider the following MIPS assembly language code and assume that the code fragment is loaded at location 80000 in the memory. What should be the values of the immediate fields of *bne* instruction and *j* instruction? (8)

```
Loop:  sll $t1,$s3,2
      add $t1,$t2,$s6
      Lw $t0, o($t1)
      bnr $t0,$s5, Exit
      addi $s3, $s3, 1
      j Loop
```

Exit:

- (d) Explain why the assembler might have problems directly implementing the branch instruction in the following code fragment. How can this problem be fixed? (7)

```
Here: beq $s0, $s2, there
```

```
...
```

```
...
```

```
there: add $s0, $s0, $s0.
```

2. Consider the single cycle datapath in Figure 2 which is constructed for *add*, *sub*, *and*, *or*, *lw*, *sw*, *beq*. Now, implement the following instructions in the datapath: *bne*, *j*, *jr*, *jal*. You need to clearly explain your implementation and mention the values of the control lines (including any additional control lines you have introduced) for the new instructions. (35)

[You may modify Figure 2 (separate sheet) and attach the update figure with your answer script after having it signed by the respected invigilator.]

Contd ..... P/2

**CSE 305**

- 3. (a) Present and explain a microprogram for the control unit of the multicycle implementation illustrated in Figure 3. (17)
- (b) Modify the implementation of Figure 3 so that it can handle the **Underfined Instruction Exception** and the **Overflow Exception**. (8)  
**[You may modify Figure 3 (separate sheet) and attach the updated figure with your answer script after having it signed by the respected invigilator.]**
- (c) Which stage should you detect the **overflow exception** in so as to ensure that the offending instruction does not change the content of the destination register? Justify your answer. (5)
- (d) Your friend claims that the *PCWriteCond* signal can be safely replaced by *PCSource[0]*. Do you agree with him? Justify your answer. (5)
  
- 4. (a) Discuss how you can detect data hazards and solve those with the help of a forwarding unit. (17)
- (b) Present a scenario when you cannot solve a data hazard with the help of a forwarding unit. Suggest what to do in this case. (13)
- (c) What is a branch hazard? (5)

**SECTION – B**

There are **FOUR** questions in this section. Answer any **THREE**.

- 5. (a) What is the average time to read or write a 512-byte sector for a typical disk rotating at 15,000 RPM? The seek time is 4 ms, the transfer rate is 100 MB/sec, and the controller overhead is 0.2 ms. Assume that the disk is idle so that there is no waiting time. (10)
- (b) What is the purpose of using RAID organization? Briefly describe the concept of different RAID levels with diagrams. (2+18)
- (c) Differentiate between NAND and NOR flash memories. (5)
  
- 6. (a) Consider a computer running program with CPU times shown in the following table: (3+3+3)

FP intr.	INT instr.	Load/Store instr.	Branch intr.	Total Time
50sec	80sec	50sec	30sec	210sec

- (i) By how much (in %) is the total time reduced if the time for FP operations is reduced by 20%?
- (ii) Assume that the time for INT operations is improved. By how much (in %) is the time for INT operations is reduced if the total time is reduced by 20%?
- (iii) Can the total time be reduced by 20% by reducing only the time for branch instructions?

**CSE 305**

**Contd ... Q. No. 6**

(b) What is the disadvantages of using virtually addressed cache? (6)

(c) "The TLB acts as a cache of the page table for the entries that map to physical pages only" – Do you agree or disagree? Explain. (7)

(d) A program accesses 2 cache blocks, one that begins at memory address 0x1000 and another one that begins at memory address 0x2000. Memory accesses alternate between these two blocks and each block is accessed 100 times.

If the program is run on a system with a 1 KB direct-mapped cache with 32 blocks, how many cache misses will occur? (13)

How many of these misses will be compulsory and conflict misses. Mention the reason behind classifying a miss as a compulsory or a conflict miss. Note that there will be no capacity miss as the total amount of data accessed by the program is less than the capacity of the cache.

7. (a) State the advantages of using write back cache. (6)

(b) If a cache has a capacity of 16 KB and a line length (block size) of 128 bytes, how many sets does the cache have if it is 2-way, 4-way and 8-way set associative? (9)

(c) Consider a processor with following parameters: (12)

Base CPI, no memory stalls: 2.0

Processor speed: 1 GHz

Main memory access time: 100 ns

First-level cache miss rate per instruction: 4%

Second level cache, direct-mapped speed: 10 cycles

Global miss rate with second-level cache, direct mapped: 4%

Second level cache, eight-way set associative speed: 20 cycles

Global miss rate with second-level cache, eight-way set associative: 1.6%

Calculate the CPI for the processor using (i) only a first-level cache, (ii) both a first-level cache and a second-level direct-mapped cache, (iii) both a first level cache and a second-level eight-way set associative cache.

(d) Briefly discuss interleaved memory organization. (4)

(e) Differentiate between fine-grain and coarse-grain multithreading. (4)

**CSE 305**

8. (a) What is the purpose of using biased notation for representing exponents of floating point numbers? (5)

(b) Draw the flowchart showing the execution steps of the division operation for the division hardware organization given below: (12)

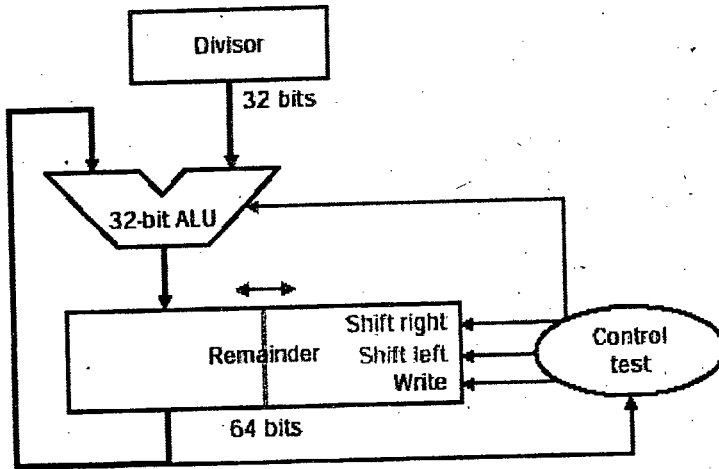

(c) Describe the steps of DMA transfer. (8)

(d) Discuss crossbar network and Omega network with diagrams. (10)

-----

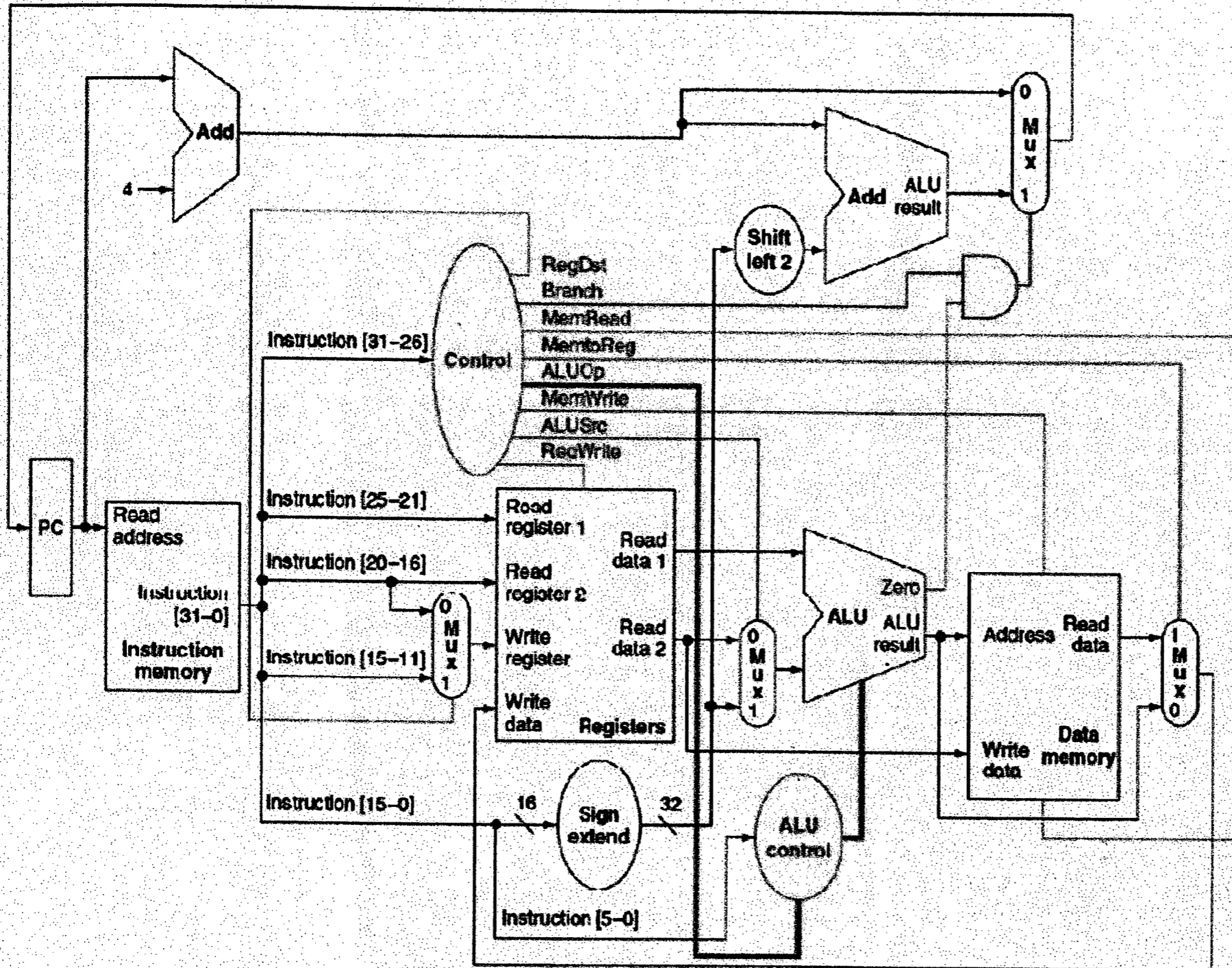

Figure - 2



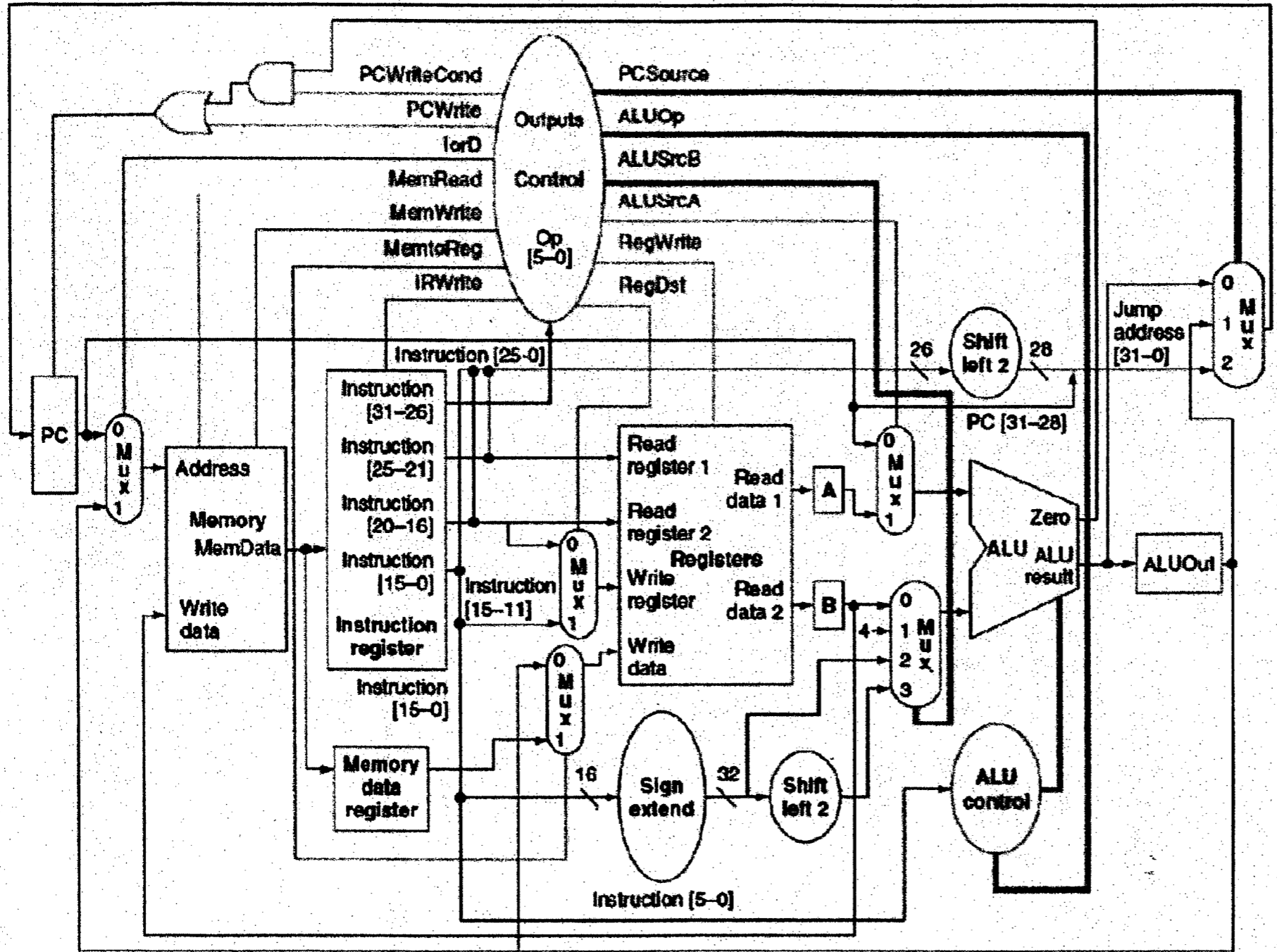

Figure - 3

**SECTION – A**

There are **FOUR** questions in this section. Answer any **THREE**.

1. (a) Differentiate between "Generic" and "Bespoke" software products with suitable examples. (5<sup>2</sup>/<sub>3</sub>)
  - (b) "Waterfall Model may lead to blocking state" – Do you agree with the statement? Why or why not? (7)
  - (c) Suppose you have to develop an application that takes a string of the format **A operator1 B operator2 C** as input and provides the result of the corresponding operation. Here, A, B and C are number string and the operator1 and operator2 are any one of +, –, \*, / operators. Which design pattern will you chose to design a solution to the problem and why? Draw the appropriate class diagram for your proposed solution approach. (4+10=14)
  - (d) Describe the phases of "Unified Process" in brief. (15)
  - (e) At the conclusion of a project that used the Unified Process, it has been determined that 30 errors were found during the elaboration phase and 12 errors were found during construction phase. The error found in the construction phase were traceable to errors that were not discovered in the elaboration phase. But no errors were found in the transition phased. What is the DRE of the elaboration phase? (5)
2. (a) Differentiate between lazy and eager initialization of Singleton pattern. Draw the structure of singleton pattern. (6+4=10)
  - (b) Draw the corresponding PERT chart of Table-1 and find out the critical path(s). (14)

Task	A	B	C	D	E	F	G	H	I	J	K
Dependency	--	--	A	B,C	C	D	E,F	G	G	H,I	J
Duration	1	3	3	5	1	4	3	2	2	5	6

Table-1 for Q. No. 2(b)

- (c) Draw the schematic diagram of RAD model and explain why it is a high speed adaptation of "Waterfall Model". (7+5=12)
- (d) Discuss use of "Project Velocity" with respect to Extreme Programming model. Provide a suitable example. (6<sup>2</sup>/<sub>3</sub>)
- (e) A Web Application and its support environment have not been fully fortified against attack. Web engineers estimate that the likelihood of repelling attack is only 30 percent. The system does not contain sensitive or controversial information, so that threat probability is 25 percent. What is the integrity of the application? (4)

**CSE 307**

3. (a) "To use LOC and FP for estimation, a historical baseline of information must be established" – explain.

(6 2/3)

(b) Suppose company A has taken up project S. Table 2 and 3 show the frequency and weight of the Function Points of project S respectively. External factors that affect project S are ranked from 0 to 5 and shown in Table 4. From historical data it can be found that the A's average productivity is 24 FP/pm and labor rate is \$ 48000 per year. Calculate the estimated project cost and effort.

(15)

FPs	Simple	Average	Complex
Inputs	2	4	6
Outputs	3	5	7
Files	5	10	15
Inquires	2	4	6
Interfaces	4	7	10

Table- 2 (Weight assignment of Function Points) for question 3(b)

FPs	Simple	Average	Complex
Inputs	-	4	2
Outputs	2	2	4
Files	2	5	1
Inquires	1	-	5
Interfaces	10	3	-

Table- 3 (Frequency of Function Points) for question 3(b)

Factor	Rank
Complex internal processing	4
Distributed processing	5
High performance	4
Multiple sites	5
Code to be reusable	3
Data Communication	5
Online Data Entry	4
Data Backup and Recovery	5

Table- 4 (External Factors) for question 3(b)

**CSE 307**

**Contd ... Q. No. 3**

(c) Consider the decision tree shown in Figure 1 for project S. Difficult implementation of project S costs the same as deduced in question 3(b). Simple implementation of project S costs 75% of the difficult implementation. Given company A's priority is cost minimization, what will be your decision regarding the implementation of project S? (12)

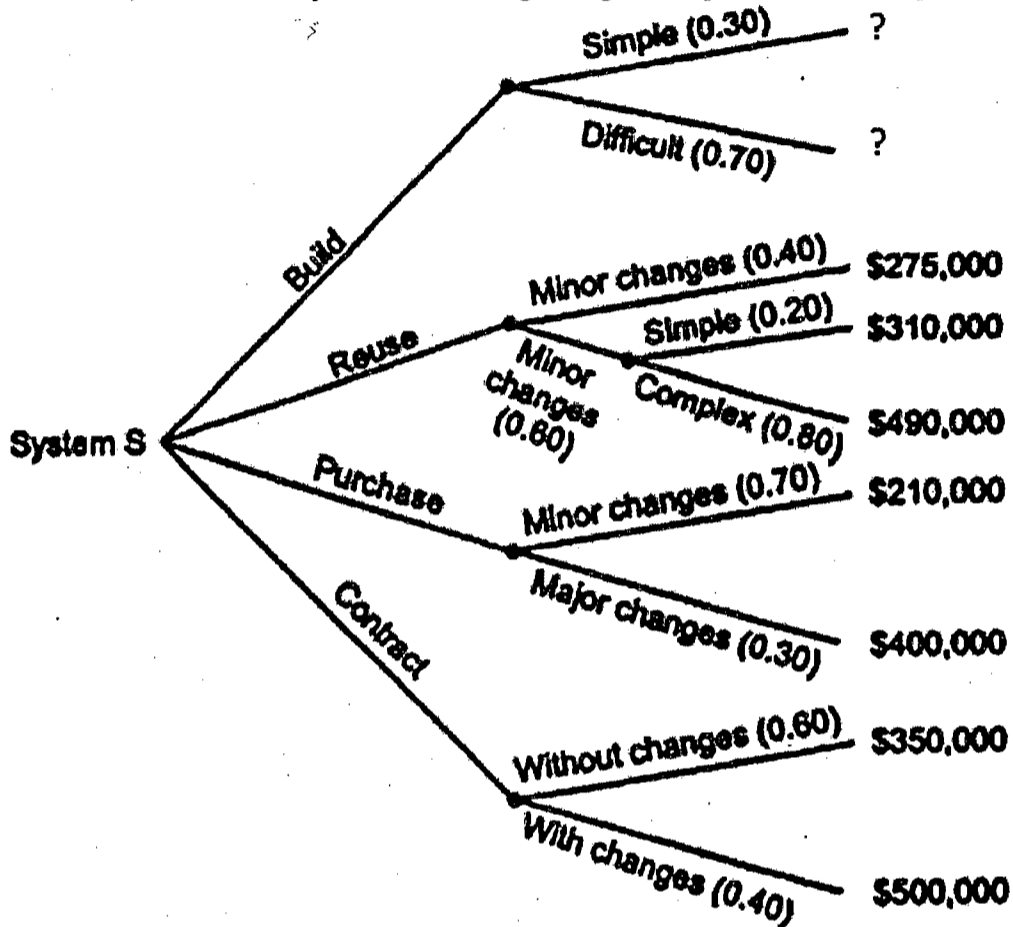

Figure -1 (Decision Tree) for Q. 3(c)

(d) Suppose your ISD lab group has been assigned to develop a "Library Management System" for BUET central library. (3+10=13)

- (i) State one possible risk that can occur for each of the following risk types: technology, tools, and requirements
- (ii) What is the probability and affect of each of the possible risks you identified? Justify your assessment.

4. (a) Suppose a project developed in C programming language. Propose four "Data faults" that should be checked during project inspection. (6)

(b) What is the primary motivation behind "Interface Segregation Principle"? With a suitable "bad example" explain the "Interface Segregation Principle". (14 2/3)

(c) Consider the following code of "Counting Sort" algorithm that sorts an integer array ar, whose elements are drawn from the range [0, k). Here, n is the length of ar (n>0). Now, draw the corresponding flow graph of "Counting Sort" algorithm and identify the independent paths. For each independent path, design suitable test cases.

```
/** Sort the n elements in ar, drawn from the values [0, k). */
```

(20)

**CSE 307**

**Contd ... Q. No. 4(c)**

```
int* countingSort (int *ar, int n, int k) {
1. int i, idx = 0
2. If(n > 1){
3.     int *B = calloc (k, sizeof (int));
4.     for (i = 0; i < n; i++) {
5.         B[ar[i]]++;
        }
6.     for (i = 0; i < k; i++) {
7.         while (B[i]-- > 0) {
8.             ar[idx++] = i;
        }
    }
9.     free(B);
}
10. return ar;
}
```

(d) Differentiate between:

- (i) Verification and Validation
- (ii) Defect Testing and Debugging

(6)

**SECTION - B**

There are **FOUR** questions in this section. Answer any **THREE**.

5. (a) The "Sweet Treat" company is a small, independent business that sells sweets and cakes to the public. The proprietor is very keen on baking and specializes in making homemade sweets and cakes for sale in the shop. Besides, making a lot of the confectionary sold in the shop, the proprietor also buys sweets and some cakes from suppliers to increase the range of products for sale.

(18)

The proprietor keeps records of the quantities of stock he has on hand. The stock includes raw ingredients for his baking, and also the sweets and cakes he buys from suppliers. Once a week proprietor checks the stock to dispose of anything that is past its 'sell by' date. He also checks to see if any raw ingredients or any pre-made sweets and cakes need to be ordered from the suppliers. The proprietor orders supplies on a 'Cash on Delivery' basis, so all deliveries are paid for immediately after they arrive.

At the end of each day, the proprietor checks how many of each homemade item have been sold. He keeps a record of these sales, and uses this to decide how many of each cake or sweet to make for the following day.

Produce a top level data flow diagram of the "Sweet Treat" company.

(b) Consider the following cash flow description for an online auction management system which is ready to develop. Amounts given in dollar value.

(15)

Assuming an 11% discount rate, what would be the payback period? Calculate annual ROI. Would be a good investment?

**CSE 307**

**Contd ... Q. No. 5(b)**

Year	Development Cost
0	588,040

Year	Estimated operation and maintenance cost	Estimated benefit
1	15,500	150,500
2	17,880	185,000
3	16,500	200,000
4	19,000	215,000
5	18,140	240,000
6	20,000	270,500

(c) Draw a collaboration diagram to illustrate the following scenario: a word-processor (active object) creates a print file and then asynchronously requests a print spooler (active object) to print the job. The print spooler repeatedly reads a block from the print file and sends the block to the printer (active object) using a procedure call.

(9)

Also draw an activity diagram of the *print file* operation.

(d) What is JRP? Who are the JRP participants?

(4 2/3)

6. (a) A grocery store has just implemented a new sales system. The system generates invoice for each sale. Consider the following collaboration diagram for *creating invoice*. (10+2+4)

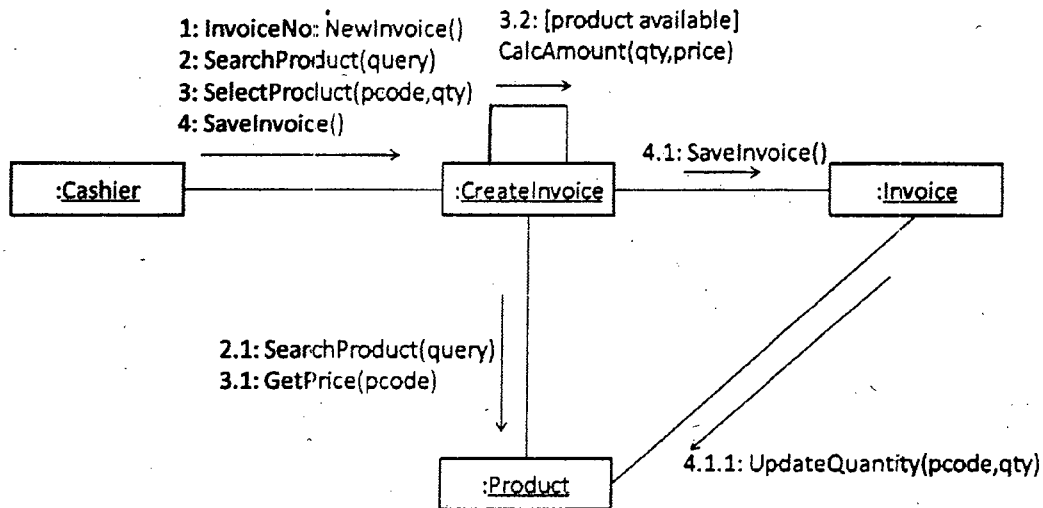

Figure 2: Collaboration diagram for 8.6(a)

Now answer the following:

- (i) Draw the sequence diagram for *creating invoice*.
- (ii) Include stereotypes for each classes.
- (iii) Find the UML Class for **Invoice**. Include everything that can be determined from the above diagram such as attributes, methods. You do not need to include information which is not contained in the above diagram.

**CSE 307**

**Contd ... Q. No. 6**

(b) Assume that a chain shopping store is going to implement an information system. Every customer is associated with a branch. If a customer purchases products worth more than Tk. 50,000 in a month, he/she becomes a super customer for that month. Super customers get special offer for purchases from any branch in the specified month. Every branch has several employees and one manager. The manager of the branch defines the offer for that branch. So, offer of one branch is not related to the offer of another branch.

Now answer the following based on the given scenario.

**(4+10)**

(i) What database tables do you need for the store?

(ii) For each database tables, find whether you should replicate or partition the data.

Justify your answer.

(c) What are the drawbacks of two-tier client-server architecture? How can the problem be solved?

**(10)**

(d) Document management system (DMS) is used to track and store electronic documents. It is usually capable of history tracking i.e., keeping track of the different versions modified by different users. Now discuss the intangible benefits of a DMS.

**(6<sup>2</sup>/<sub>3</sub>)**

7. (a) Give a state diagram that describes the process of passing a graduate course as a set of concurrent activities. The process works as follows: To pass, a student has to attend all but two lectures, present to the class a paper she read, and complete a course project, due on the last day of the term. To give her presentations, the student is given a date by the instructor, prepares her presentation, and gives it on the assigned day. At any time, the student can drop the course.

**(15)**

Define events, conditions and actions for transitions in your diagram, where appropriate.

(b) Assume that you are designing an information system for a health center. Possible users of your system are doctor, nurse, patient, receptionist, pharmacist, attendant and patient. What are the seven fact finding methods? Argue which fact finding method(s) you should select for each user?

**(15)**

(c) Different librarians work in different shifts in the university central library. The library contains multiple copies of each book. Each book is written by one or more authors and published by a publisher. A user may borrow up to 10 books at a time. User returns a borrowed book to the librarian working in that shift. Now design a class diagram with attributes and associations based upon the above scenario. You don't have to show any methods.

**(12)**

(d) What are the different kinds of *things* in UML?

**(4<sup>2</sup>/<sub>3</sub>)**

8. (a) The Northeast Hotel's website allows potential guests to make a room reservation, specifying the dates and type of room. If they have registered with the website previously, their stored details are used to speed up the process; otherwise they are required to register as a new customer. Each reservation is given a unique reservation code. Before the date of their stay, they may enter this reservation code into the website to amend or cancel the reservation.

**CSE 307**

**Contd ... Q. No. 8(a)**

Amendments can include altering the dates, changing the room type or the number of guests in each room. When the guests arrive at the hotel the reservation id is used by the receptionist to quickly find the reservation to check them in. At the end of their stay, the receptionist checks the guests out. At this point, the hotel system validates their payment through the card payment system. A printed invoice may be requested by the guests. The hotel has many room types available, each with a room-type name, number of guests and additional facility information. Each room in the hotel has a room number and is of one specific type. Monthly reports are prepared by the system which may be viewed on request by the Hotel Manager.

(15+5)

(i) Produce a System Use Case diagram for the above scenario.

(ii) Also give the Use Case Dependency diagram.

(b) What does the abbreviation CRC stand for? Name two benefits derived from the use of CRC when used for class modeling?

(5)

(c) A fellow designer has asked you to review the dialogue to be used in several screens for a new application. Give your opinion about the following messages based on the guidelines of tone and terminology.

(5)

(i) **An error message that says DISCHARGE, DATE MUST BE ON OR AFTER ADMISSION DATE.**

(ii) **An instruction that says ENTER THE CLIENTS NAME NOW.**

(iii) **An error message that says DATA IS SO FAR OUT OF RANGE IT HAS LEFT THE SOLAR SYSTEM.**

(iv) **A question that asks DO YOU WANT TO RDF THE ACR BEFORE "UCI ING" CMIS?**

(v) **An error message that says DONT WORRY-NOT EVERONE GETS IT RIGHT THE FIRST TIME.**

(d) Define (any three):

(9)

(i) Stratification of Sampling Method

(ii) Batch Input Processing

(iii) Stub Test

(iv) POS Terminal

(v) Reverse Engineering

(e) Suppose you have applied for a building permit. The authority, after receiving the application, reviews it for completeness. From this stage, the verified application is forwarded for compliance checking. The authority has to review the application for zone compliance and environment compliance. Further permission or registration for towers may be needed from aviation authorities. If all criteria are fulfilled, the authority will issue you the building permit. Now give the decomposition diagram of the "Building Permit Application Process System".

(7<sup>2</sup>/<sub>3</sub>)

-----



**SECTION – A**

There are **FOUR** questions in this section. Answer **Q. No. 1** and any **TWO** from the rest.

1. Define "Basic Module" of Islamic architecture that originated during Khilji or Khalji dynasty. Use tomb of Iltutmish and Alai darwaza as reference. Draw necessary sketches. **(30)**
2. (a) What is the first attempt of slave dynasty's important building scheme? Graphically represent its stages. **(14)**  
(b) Draw plan and section of Militant Palace of Firoz Shah Kotla. **(6)**
3. (a) Explain with sketches the architectural characteristics of Hauz-Khas. **(12)**  
(b) Explain the uniqueness of "Khirki Mosque". **(8)**
4. Write short notes on the following: **(2×10=20)**
  - (i) Qutb Minar
  - (ii) Sultan Ghari's Tomb

**SECTION – B**

There are **FOUR** questions in this section. Answer **Q. No. 5** and any **TWO** from the rest.

5. Write short notes on the following topics: **(3×8=24)**
  - (a) Akbar's all India architecture
  - (b) Buland Darwaza
  - (c) Delhi Jami Mosque
6. (a) Critically evaluate the architectural character and features applied in plans, elevations and sections of the 'Jahangiri Mahal'. **(13)**  
(b) "The Mughal garden attempted to capture natural beauty within a man-made framework" – discuss with necessary illustrations. **(10)**

**ARCH 341**

7. (a) Describe the 'Tomb of Humayun' as a fusion and logical synthesis of two great architectural traditions with necessary illustrations. **(13)**
- (b) 'Taj Mahal is a complete architectural experience'. – explain with reference to concept and zoning. Use necessary sketches. **(10)**
8. Critically describe the following aspects of 'Fatehpur Sikri' with illustrations – **(23)**
- (a) Concepts of planning
  - (b) Visual unity and diversity
  - (c) Material and landscape
-

**SECTION – A**

There are **FOUR** questions in this section. Answer any **THREE**.

1. (a) (i) In Bipolar NRZ-L line coding , 1 is represented by 5V and 0 is represented by –5V during bit duration. Now, explain why Bipolar NRZ-L suffers from synchronization problems for both long run of 1's and 0's. **(4+4+4+4+4)**
- (ii) With proper explanation, give an example of a line coding technique that uses the same bandwidth as Bipolar NRZ-L but solves the synchronization problem for long run of 1's (though synchronization problem for long 0's still exists).
- (iii) With proper explanation, give an example of a line coding technique that solves the synchronization problems for both long run of 1's and 0's but requires twice the bandwidth of Bipolar NRZ-L.
- (iv) Describe how 'Block Coding' attempts to solve the synchronization problem with "NRZ-I". Does "Block Coding" affect the bandwidth of the resulting signal? Explain with an example.
- (b) Five signals, each covering the range 20-80 KHz are to be transmitted simultaneously using Frequency Division Multiplexing (FDM). The resultant signal should cover the range 300-700 KHz where frequency gap (guard band) of 25 KHz is provided between each pair of consecutive channels for interference reduction. See Figure 1(b) for an illustration. Now, describe how to generate the desired frequency multiplexed signal. **(15)**

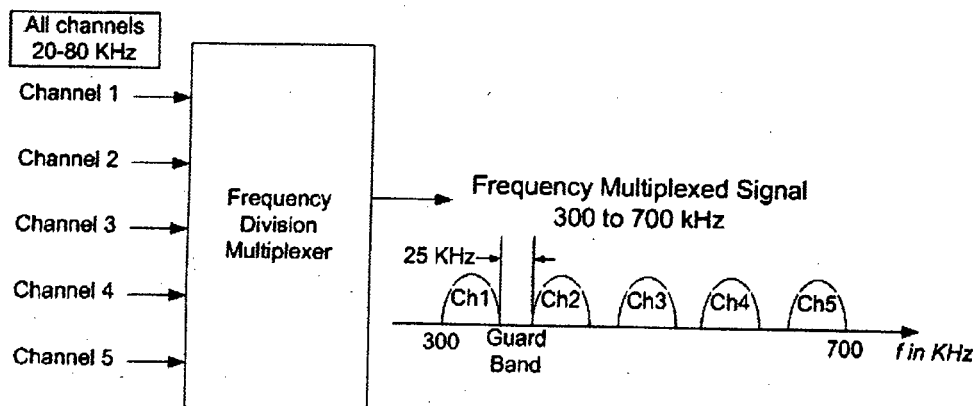

Figure 1(b)

**CSE 311**

2. (a) For each the following three modulation techniques for binary digital data, determine the bandwidth of the modulated signal when the baseband bandwidth of the modulating signal is B Hz. (12)
- (i) Amplitude Shift Keying (ASK), (ii) Frequency Shift Keying (FSK), and (iii) Phase Shift Keying (PSK).
- (b) Draw the block diagrams for – (i) Noncoherent (asynchronous) detection of FSK, and (ii) coherent (synchronous) detection of FSK. (4+4)
- (c) (i) Explain with an example, how M-ary signaling achieves higher data rate than binary signaling using the same bandwidth but at the cost of more power. (7+8)
- (ii) Show that for M-ary FSK, the minimum frequency separation to ensure orthogonality among the FSK symbols is:  $\delta f = 1/2T_b$  where  $T_b$  denotes the symbol duration.
3. (a) Explain how the circuit in Figure 3(a) functions as an envelope detector for AM (Amplitude Modulation) signal. Describe how to choose the constants 'R' and 'C' in the circuit for envelope detection of a given AM signal. (8+4)

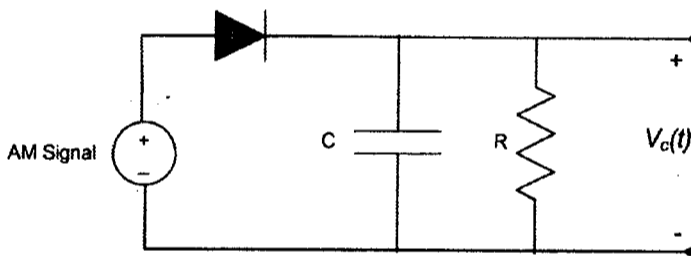

Figure 3(a)

- (b) Show that, for a real time function  $f(t)$ , the signal,  $f_{SSB}(t) = f(t) \cos \omega_c t + f_h(t) \sin \omega_c t$  represents a lower sideband SSB-SC signal where  $f_h(t)$  represents the Hilbert Transform of  $f(t)$  and  $\omega_c$  is the carrier frequency in rad/sec. (14)
- (c) Describe how Quadrature Amplitude Modulation (QAM) is performed. Explain why QAM is bandwidth efficient than DSB-SC modulation. (4+5)
4. (a) A baseband signal  $f(t)$  of bandwidth B is modulating the frequency of a carrier at frequency  $\omega_c$  (in rad/sec). Show that, the resulting frequency modulated signal can be expressed as – (5+2+8+5+3)

$$f_{FM}(t) = A \cos \left[ \omega_c t + k_f \int_{-\infty}^t f(a) da \right] \quad \text{where, } k_f \text{ is a constant.}$$

**CSE 311**

**Contd ... Q. No. 4(a)**

Under what condition, an FM signal is called Narrowband FM (NBFM). Applying the condition on the above expression of an FM signal, show that a narrowband FM signal can be approximated as:

$$f_{NBFM}(t) \approx A \left[ \cos \omega_c t - k_f a(t) \sin \omega_c t \right] \quad \text{where } a(t) = k_f \int_{-\infty}^t f(a) da$$

Draw the block diagram of a narrowband FM generator according to this expression.

What is the problem of generating NBFM signals in this way?

(b) 'Angle modulation is preferable over Amplitude modulation for systems where nonlinear amplifiers are used'. Justify the statement by showing how Angle Modulation is immune to nonlinearities whereas Amplitude Modulation suffers from distortion during nonlinear amplification.

(12)

**SECTION - B**

There are **FOUR** questions in this section. Answer any **THREE**.

5. (a) Define unit impulse function. Derive the sampling property of unit impulse function.

(8)

(b) The convolution of two functions  $g(t)$  and  $w(t)$ , denoted by  $g(t)*w(t)$ , is defined by the

integral:  $g(t)*w(t) = \int_{-\infty}^{\infty} g(\tau)w(t - \tau) d\tau$ . Now, prove that the convolution of two signals in

the time domain becomes multiplication in the frequency domain and vice versa.

(14)

(c) The Fourier transform of a function  $g(t)$  is expressed as:  $G(f) = \int_{-\infty}^{\infty} g(t) e^{-j2\pi ft} dt$ .

Find the Fourier transform of  $g(t) = \Pi(t/\tau)$  in Figure 5(c).

(13)

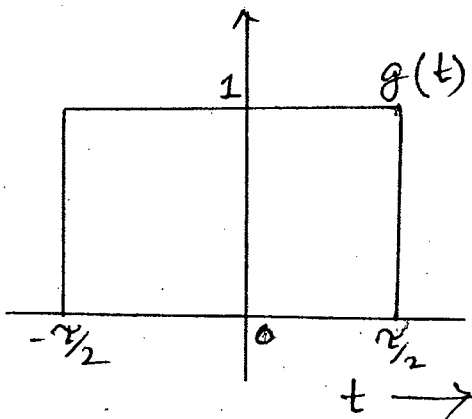

Figure: 5(c)

**CSE 311**

6. (a) Describe how DPCM system works with suitable block diagrams of both transmitter and receiver. (12)
- (b) State and prove the Time-Shifting property and the Frequency Shifting property of Fourier Integral. (10)
- (c) How does 'Inter-Symbol Inference (ISI)' occur in digital transmission system? Explain how ISI can be eliminated using "pulse shaping". (13)
7. (a) Show that for a distortionless system, the amplitude response  $|H(f)|$  must be a constant, and the phase response  $\theta_h(f)$  must be a linear function of  $f$  going through the origin. (8)
- (b) Describe how TDM (Time Division Multiplexing) Digital Hierarchy works. Why bit stuffing and framing are used in TDM? (14)
- (c) A low-pass filter (Figure 7(c.1) transfer function  $H(f)$  is given by (13)

$$H(f) = \begin{cases} (1 + k \cos 2\pi f T) e^{-j2\pi f t_d}, & |f| < B \\ 0, & |f| > B \end{cases}$$

A pulse  $g(t)$ , band-limited to B Hz (Figure 7(c.2), is applied at the input to this filter.

Show that the output is  $y(t) = g(t - t_d) + \frac{k}{2} [g(t - t_d - T) + g(t - t_d + T)]$

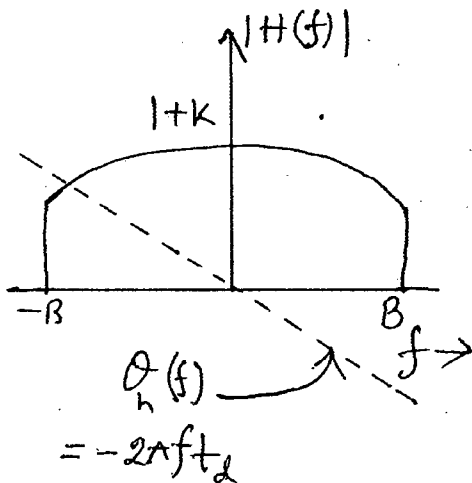
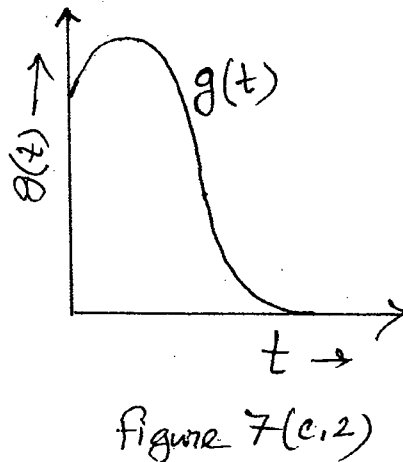

figure: 7(c.1)



8. (a) Prove that the minimum sampling frequency for perfect signal recovery is  $f_s = 2B$  Hz. Assume conventional meaning of the symbol. (15)
- (b) How quantization is done in a PCM system? Why non-uniform quantization is suitable for voice signal? How does companding achieve non-uniform quantization? (6+6+8=20)

**SECTION - A**

There are **NINE** questions in this section. Answer any **SEVEN**.

1. (a) With necessary examples (and figures if necessary), justify the statement, "A compiler involves only compilation, a hybrid compiler involves both compilation and interpretation, an interpreter involves only interpretation but no compilation". (10)  
 (b) Explain why "relocatable machine code" is called "relocatable"? (5)
  
2. Enumerate the compiler construction tool kits with necessary description and applicable examples. (15)
  
3. (a) Why is the analysis portion of a compiler normally separated into lexical analysis and syntax analysis phases? What is wrong with using only the parser to accomplish both the lexical analysis and syntax analysis? (10)  
 (b) "The token name influences parsing decisions, while the attribute value influences translation of tokens after the parse" – explain. (5)
  
4. We want to develop the transition diagram for certain operators in a programming language. The operators are, =, !=, >, <, >=, <=. Show using an appropriate transition diagram how these operators can be tokenized in lexical analysis. Also suggest necessary attributes for tokens wherever needed. (15)
  
5. Explain clearly the difference among the following regular expressions in the context of Lex lexical analyzer generator. (15)
  - (i) {cse}{buet}
  - (ii) [csebuet]
  - (iii) {csebuet}
  - (iv) csebuet
  - (v) (csebuet) +
  - (vi) csebuet +

**CSE 309**

6. Eliminate left recursion from each of the following grammars.

(a)  $S \rightarrow S + S \mid SS \mid T$  (7)  
 $T \rightarrow TT \mid T \mid I$   
 $I \rightarrow IO \mid I1 \mid 0 \mid 1$

(b)  $S \rightarrow Sa \mid Tb \mid c$  (8)  
 $T \rightarrow Tx \mid Sy \mid z$

7. Left-factor this grammar, (15)

$S \rightarrow T; S \mid \epsilon$   
 $T \rightarrow U * T \mid U$   
 $U \rightarrow x \mid y \mid [S]$

Hence find FIRST and FOLLOW sets for each non-terminal in the left-factored grammar.

8. Justify whether the following grammar is LL(1) or not. (15)

$S \rightarrow AaAb \mid BbBa$   
 $A \rightarrow \epsilon$   
 $B \rightarrow \epsilon$

If it is not an LL(1) grammar, carry out necessary processing to make it LL(1). Hence, construct a predictive parsing table from this grammar. Then show how the strings *ab*, *ba* and *abb* are parsed by this grammar.

9. Present the SDD which uses inherited attributes to multiply integers. Use this SDD to construct an annotated parse tree to carry out the multiplication  $3 \times 4 \times 5$ . (15)

**SECTION – B**

There are **FOUR** questions in this section. Answer any **THREE**.

10. (a) What is type inference? Determine the type inference rule for the following function written in ML language: (10)

```
fun append(x, y) = if null(x) then y
                  else cons(hd(x), append(tl(x), y))
```

where *null(x)* is a function that returns **true** if the list *x* is empty and **false** otherwise, and *cons(src, dest)* is a function that concatenates "src" with "dest".

(b) Consider the following grammar for generating binary fractions. (10)

$F \rightarrow 0.B$   
 $B \rightarrow 0B \mid 1B \mid 0 \mid 1$



**CSE 309**

**Contd ... Q. No. 10(b)**

Fill in the missing semantic actions below to calculate the decimal value of an input string. Recall that the numeric value of a binary fraction  $0.b_1b_2 \dots b_n$  is calculated as each non-terminal has a synthesized attribute *val* that is used to store its value. The final value should be returned in *F.val*.

$F \rightarrow 0.B \{F.val = B.val\}$

$B_0 \rightarrow 0B_1 \{ \quad \}$

$B_0 \rightarrow 1B_1 \{ \quad \}$

$B \rightarrow 0 \{ \quad \}$

$B \rightarrow 1 \{ \quad \}$

(c) Draw symbol table structure for the following program that takes care of scope: (10)

```
struct S
{ int a;
  int b;
} s;
void swap(int& a, int&b)
{ int t;
  t = a;
  a = b;
  b = t;
}
void foo()
{ ...
  swap(s.a, s.b);
  ...
}
```

(d) Consider the following C type declaration of a binary tree node: (5)

```
struct IntBinTree{
  int val;
  struct IntBinTree *left;
  struct IntBinTree *right;
} tree;
```

Draw the cyclic type graph for tree (as would be constructed by a compiler).

11. (a) What is a type system? What is a strongly typed language? (5)

(b) Provide syntax directed definition and determine post system proof for correct typing of the following statements: (15)

**CSE 309**

**Contd ... Q. No. 11(b)**

- (a)  $S \rightarrow id := E$
- (b)  $S \rightarrow S_1 ; S_2$
- (c)  $S \rightarrow \text{while } E \text{ do } S_1$

(c) What is the syntax directed definition for the following boolean expressions (15)

- (a)  $B \rightarrow B_1 \parallel B_2?$
- (b)  $B \rightarrow \text{true}$
- (c)  $B \rightarrow E_1 \text{ rel } E_2$

where **rel** indicates a relational operator.

12. (a) Describe static and dynamic scoping and how they differ. Give an example of a program that has different output assuming static versus dynamic scoping. (10)

(b) Consider the following program: (20)

```
program P()
  var p : integer;
  procedure Q(k : integer)
    begin
      R(k, p)
    end
  procedure R(i : integer, j : integer);
    var n : integer
    procedure T(i : integer)
      begin
        ... (* body of T *)
      end;
    procedure S()
      var m : integer
      begin
        T(n)
      end;
    begin
      S()
    end;
  begin
    Q(p)
  end
```

(i) Program P calls Q, Q in turn calls R, R in turn calls S, and S in turn calls T. Draw the resulting stack layout with activation records. Show the arguments and local variables in each record and draw the access links.

**CSE 309**

**Contd ... Q. No. 12(b)**

(ii) Which variables are visible (in scope) in the body of T and how many access links must be traversed to reach the nonlocal data?

Var	visible (Y/N)	# links
i		
j		
k		
m		
n		
p		

(c) What are the three proposed evaluation methods for semantic rules to decorate parse trees? Explain. (5)

13. (a) Partition the following fragment of three-address codes into basic blocks and construct the control flow graph. (10)

```

        if n>0 goto L1
        goto L3
L1:    i := 0
        f := 1
L2:    i := i + 1
        f := f * i
        if i<n goto L2
        goto L4
L3:    f := 0
L4:    halt
    
```

(b) What are peephole optimizations? Name and explain three peephole optimizations with examples. (10)

(c) What do you know about *register descriptor* and *address descriptor*? Generate code of the statements of the following table and fill up the value of the descriptions. (10)

Statements	Code generated	Register Descriptor	Address Descriptor
t := a - b			
u := a - c			
v := t + u			
d := v + u			

(d) Give three examples of tasks that are typically performed in a type checker. What types of errors are recognized in a type checker? (5)

-----