

SECTION – A

There are **FOUR** questions in this section. Answer any **THREE**.

1. (a) Mention Location, Purpose and Mechanism of the following Lathe elements. **(16 $\frac{2}{3}$)**
(i) Sliding cluster gear (ii) Rack and pinion (iii) clutches (iv) Half nut.
(b) Discuss different types of Rests. Explain their necessity in lathe operation. **(12)**
(c) Discuss the Taper turning attachment and Two feed method of taper turning in detail with necessary sketches. **(18)**
2. (a) Explain different types of Milling Machine. **(10)**
(b) Explain the principle of differential Indexing. Also discuss the consequences arises due to the presence of Left/Right hand worm in the dividing head. **(20)**
(c) Draw a sketch to show the different elements of ball bearing. Also discuss the ball inserting mechanism in ball bearing. **(16 $\frac{2}{3}$)**
3. (a) How much do you need to pre-load a bearing for spindle assembly? Explain briefly. **(15)**
(b) Discuss the cutter setting mechanism in gear hobber for spur and helical gear. **(15)**
(c) Why do you prefer generating principle of gear cutting? Explain briefly. **(16 $\frac{2}{3}$)**
4. (a) What are the requirements of machine tools structure? Explain briefly. **(16 $\frac{2}{3}$)**
(b) Discuss the effect of chip on machine tool structure design. **(10)**
(c) Discuss the methods of measuring accuracy of straightness of Lathe machine and angular accuracy of gear shaper. **(20)**

Contd P/2

IPE 401/IPE

SECTION – B

There are **FOUR** questions in this section. Answer any **THREE**.

5. (a) Show that the maximum relative loss of cutting speed, formative capacity, production volume are constant for a certain machine, which is following GP-series. (20)
- (b) Describe the Meander gearbox with schematic diagram. Mention the expressions of transmission ratios from the schematic diagram. (18 $\frac{2}{3}$)
- (c) An axial piston pump with swash plate rotates at 1800 rpm. Calculate its maximum supply capacity if the following dimensions are given: (8)
- Number of pistons = 12
- Piston diameters = 5 mm
- Radius of the piston circle = 30 mm
- Maximum angle of inclination of the swash plate = 30°
6. (a) Describe the Ward-Leonard set with schematic diagram. (20)
- (b) Explain working principle of Norton Gearbox with schematic diagram. What are the advantages of Norton Gearbox? (20 $\frac{2}{3}$)
- (c) Write down the limitations of vane pump. (6)
7. (a) Explain travel control through a dropping worm with necessary sketches. (20)
- (b) Describe with neat sketches, the working principle of hydro-static slideways. (18 $\frac{2}{3}$)
- (c) What are the requirements to design slideways in a machine tool? (8)
8. (a) Write down the kinematic advantages of GP-series. (15)
- (b) Write down the advantages and disadvantages of CNC machine tools. Explain, in brief, the 3-2-1 principle of location. (13+8)
- (c) Describe the advantages and limitations of plastic slideways. (10 $\frac{2}{3}$)
-

BANGLADESH UNIVERSITY OF ENGINEERING AND TECHNOLOGY, DHAKA

L-4/T-1 B. Sc. Engineering Examinations 2012-2013

Sub : **IPE 405** (Theory of Machine Tool Mechanism)

Full Marks: 140

Time : 3 Hours

USE SEPARATE SCRIPTS FOR EACH SECTION

The figures in the margin indicate full marks.

SECTION – AThere are **FOUR** questions in this section. Answer any **THREE**.

1. (a) A rotating shaft carries four masses A, B, C, and D which are radially attached to it. The mass centers are 30 mm, 38 mm, 40 mm and 35 mm respectively from the axis of rotation. The masses A, C and D are 7.5 kg, 5 kg and 4 kg respectively. The axial distances between the planes of rotation of A and B is 400 mm and between B and C is 500 mm. The masses A and C are at right angles to each other. Now, for a complete balance please find the following: (15)
- (i) The angles between the masses B and D from mass A.
 - (ii) The axial distance between the planes of rotation of C and D.
 - (iii) The magnitude of mass B.
- (b) A shaft of 180 mm diameter is supported in two bearings 2.5 metres apart. It carries three discs of mass 250 kg, 500 kg and 200 kg at 0.6 m, 1.5 m and 2 m from the left hand. Assuming the mass of the shaft as 190 kg/m determine the critical speed of the shaft. Young's Modulus for the material of the shaft is 211 GN/m^2 . (8 $\frac{1}{3}$)
2. (a) A machine of mass 75 kg is mounted on springs and is fitted with a dashpot to damp out vibrations. There are three springs each of stiffness 10 N/mm and it is found that the amplitude of vibration diminishes from 38.4 mm to 6.4 mm in two complete oscillations. Assume that, the damping force varies as velocity, determine (13)
- (i) the resistance of the dashpot at unit velocity;
 - (ii) the ratio of the frequency of the damped vibration to the frequency of the undamped vibration;
 - (iii) the periodic time of the damped vibration.
- (b) What is "Critical speed" of a shaft? Prove that "Critical speed" is the same as the natural frequency of transverse vibration. (10 $\frac{1}{3}$)

IPE 405/IPE

3. (a) Three rotors A, B and C having moment of inertia of 2000; 6000; and 3500 kg-m² respectively are carried on a uniform shaft of 0.35 m diameter. The length of the shaft between the rotors A and B is 6 m and between B and C is 32 m. Find the position of nodes and natural frequency of torsional vibrations. The modulus of rigidity for the shaft material is 80 GN/m². (12 1/3)
- (b) A machine of mass 100 kg is supported on openings of total stiffness 800 kN/m and has a rotating unbalanced element which results in a disturbing force of 400 N at a speed of 3000 r.p.m. Assuming the damping ratio as 0.25, determine (11)
- (i) the amplitude of vibrations due to unbalance and
- (ii) the transmitted force.
4. (a) Briefly describe the steps of determining free torsional vibrations of a geared system. (10)
- (b) Determine the natural frequencies of torsional vibration for a system in which a reciprocating I.C. engine is coupled to a centrifugal pump through a pair of gears. The shaft from flywheel of the engine to gear wheel is of 60 mm diameter and 950 mm in length. The shaft from pinion to pump is of 40 mm diameter and 300 mm in length. The engine speed is 1/4 th of pump speed. (13 1/3)
- Moment of inertia of flywheel = 800 kg-m²
- Moment of inertia of gearwheel = 15 kg-m²
- Moment of inertia of pinion = 4 kg-m²
- Moment of inertia of pump = 17 kg-m²
- Modulus of rigidity for shaft material is 84 GN/m².

SECTION – B

There are **FOUR** questions in this section. Answer any **THREE**.

5. (a) Explain why only a part of the unbalanced force due to reciprocating masses is balanced by revolving mass. (5 1/3)
- (b) Derive the following expressions, for an uncoupled two cylinder locomotive engine: (18)
- (i) Variation in tractive force;
- (ii) Swaying couple; and
- (iii) Hammer blow

IPE 405/IPE

6. (a) Write a short note on primary and secondary balancing. (5 1/3)
- (b) The following data apply to an outside cylinder uncoupled locomotive: Mass of rotating parts per cylinder = 360 kg; Mass of reciprocating parts per cylinder = 300 kg; Angle between cranks = 90°; Crank radius = 0.3 m; Cylinder centres = 1.75 m; Radius of balance masses = 0.75 m; Wheel centers = 1.45 m. If whole of the rotating and two-thirds of reciprocating parts are to be balanced in planes of the driving wheels, find: (18)
- (i) Magnitude and angular positions of balance masses,
 - (ii) Speed in kilometers per hour at which the wheel will lift off the rails when the load on each driving wheel is 30 kN and the diameter of tread of driving wheels is 1.8 m, and
 - (iii) Swaying couple at speed arrived at in (ii) above.
7. (a) What is the difference between forced vibration and self excited vibration? Briefly discuss the effects of vibration on cutting condition. (11 1/3)
- (b) What are the main sources of vibration in machine tool? Discuss how unbalance and disturbances in drives and intermittent cutting induce vibration in machine tool. (12)
8. (a) Explain in detail "Phase lag theory" proposed by Doi and Kate. (8 1/3)
- (b) How does tool wear affect the vibration amplitude? Briefly explain lathe chatter considering two directional motion of cutting tool. (15)
-

BANGLADESH UNIVERSITY OF ENGINEERING AND TECHNOLOGY, DHAKA

L-4/T-1 B. Sc. Engineering Examinations 2012-2013

Sub : **IPE 407** (Ergonomics and Safety Management)

Full Marks : 210

Time : 3 Hours

The figures in the margin indicate full marks.

USE SEPARATE SCRIPTS FOR EACH SECTION

SECTION – A

There are **FOUR** questions in this Section. Answer any **THREE**.

1. (a) Discuss the principles of hand tool and device design. (20)
 (b) Write short notes on the following (15)
 (i) Tenosynovitis (ii) Carpal Tunnel Syndrome (iii) Tennis Elbow
2. (a) Discuss the general principles for seat design (20)
 (b) Define workspace. Explain the effects of the presence of restraints, effects of manual activity and the effects of apparel on workspace envelope. (15)
3. (a) Discuss the contractibility of muscle. (10)
 (b) Describe basal metabolism (10)
 (c) Discuss the factors affecting energy consumption during physical work. (15)
4. (a) What are the personal factors that affect strength? Explain (20)
 (b) Explain in details about the approaches for assessing Manual Material Handling capabilities and for setting recommended workloads. (15)

SECTION – B

There are **FOUR** questions in this Section. Answer any **THREE**.

5. (a) What is your definition of the term *safety*? How does it differ from the professional definition of this term? (7)
 (b) Discuss the roles and responsibilities of safety and health professionals. (10)
 (c) What is pilot error syndrome? Discuss its consequences. (10)
 (d) Is workers' compensation beneficial to the employer? Although it costs the employer money, why is it desirable from the employer's perspective? (8)
6. (a) Discuss different types of *loss exposures* with examples. (7)
 (b) What are the categories of *control techniques*? Briefly discuss how you can eliminate or reduce loss exposures with the aid of these techniques. (15)
 (c) Distinguish between *loss control* and *loss prevention* with suitable examples. (7)
 (d) What are the categories of *injuries*? (6)

IPE 407

7. (a) Suppose you have been asked to devise a risk mitigation strategy. What are the information that you may need? How do you collect them? (10)
- (b) What is meant by system safety? Briefly discuss how you can apply the concept of system safety at different phases of system life cycle. (13)
- (c) Discuss how you can apply *Multiple Factors Theory* in the investigation of fire incidents in RMG industries. (12)
8. (a) Discuss the effects of wearing gloves on manual performance. (10)
- (b) Describe the problems associated with measuring heart rate. (10)
- (c) What are the methods of reducing the risk of manual material handling overexertion? Explain. (15)
-

SECTION – A

There are **FOUR** questions in this section. Answer any **THREE**.

1. (a) Define work volume. Draw body-arm assembly and work volume for polar, cylindrical and Cartesian coordinate robot configuration. (10)
(b) Briefly explain the process of controlling actuators of the individual joints in a coordinated fashion for the manipulator to perform a desired motion cycle. Discuss different types of controllers in short. (25)
2. (a) What do you understand by discrete process control? Give some examples of binary sensors and actuators used in discrete process control. (7)
(b) List the advantages of a PLC over relays. Briefly explain various components and operating cycles of a PLC. (18)
(c) Draw ladder logic diagrams (at least two) for a relay based controller that will allow three switches in a room to control a single light. (10)
3. (a) What are the differences between traditional manufacturing systems and flexible manufacturing systems? (5)
(b) Define different types of flexibilities and list the factors on which they depend. (10)
(c) What are the basic components of an FMS? Briefly discuss each of them. (20)
4. (a) What do you understand by process planning? List the decisions usually included within the scope of process planning. (8)
(b) Using a simple example explain a typical route sheet for specifying process plan. (7)
(c) Classify CAPP systems. Which system do you believe will better meet the current demand of complex part manufacturing? Why? Also discuss a retrieval CAPP system in brief. (20)

IPE 419/IPE

SECTION – B

There are **FOUR** questions in this section. Answer any **THREE**.

5. (a) Briefly explain 7 layer open system interconnection model. (10)
 (b) How can you distinguish MAP from TOP? (5)
 (c) Describe different network topology with neat sketch. (15)
 (d) Write down the application areas for LAN, MAN and WAN. (5)
6. (a) What are the three considerations in "Material Handling" system design? (8)
 (b) Explain different types of AGV with appropriate application. (12)
 (c) Identify part families and corresponding machine groups for the following part machine matrix using rank-order clustering technique: (15)

Part	Machine									
	A	B	C	D	E	F	G	H	I	J
1	1	1				1	1			1
2			1	1	1			1		
3	1	1					1		1	1
4			1	1	1					
5						1	1			
6			1							
7	1	1					1		1	1
8				1	1					1

7. (a) There are three different ways for grouping products into cell. Do you think visual checking is a better ways to serve the above purpose? Justify your answer with example. (8)
 (b) For the following machine cell, derive the sequence of operations along with the product flow: (12)

Machine	To				
	From	A	B	C	D
A	–	15	30	20	25
B	5	–	20	25	10
C	20	35	–	10	20
D	15	5	15	–	35
E	10	25	20	15	–

IPE 419/IPE

Contd... Q. No. 7

(c) Write down the code of the following component using Opitz system:

(7)

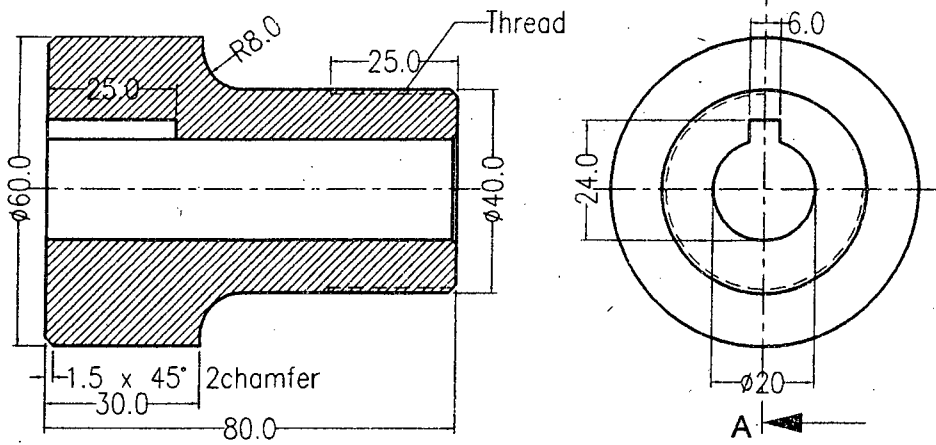

SECTION-AA

(d) Briefly describe part classification and coding system.

(8)

8. (a) What do you understand by manufacturing support system? Compare process planning and production planning.

(5)

(b) Briefly explain design process proposed by Shigley. Also discuss about the application of CAD in four of the design phases.

(10)

(c) Define Computer Aided Manufacturing (CAM). Explain application of CAM in manufacturing planning and manufacturing control related activities.

(20)

Digit 1		Digit 2		Digit 3		Digit 4		Digit 5	
Part class		External shape, external shape elements		Internal shape, internal shape elements		Plane surface machining		Auxiliary holes and gear teeth	
0 Rotational parts	$L/D \leq 0.5$	0	Smooth, no shape elements	0	No hole, no breakthrough	0	No surface machining	0	No auxiliary hole
	$0.5 < L/D < 3$	1	No shape elements	1	No shape elements	1	Surface plane and/or curved in one direction, external	1	Axial, not on pitch circle diameter
	$L/D \geq 3$	2	Thread	2	Thread	2	External plane surface related by graduation around the circle	2	Axial on pitch circle diameter
		3		Functional groove		3		Functional groove	
		4	No shape elements		4	No shape elements	4		External groove and/or slot
		5	Thread	5	Thread	5	External plane surface and/or slot, external spline	5	Axial and/or radial on PCD and/or other directions
	6	Functional groove	6	Functional groove	6	Internal plane surface and/or slot	6	Spur gear teeth	
7 Nonrotational parts		7	Functional cone	7	Functional cone	7	Internal spline (polygon)	7	Bevel gear teeth
		8	Operating thread	8	Operating thread	8	Internal and external polygon, groove and/or slot	8	Other gear teeth
		9	All others	9	All others	9	All others	9	All others

BANGLADESH UNIVERSITY OF ENGINEERING AND TECHNOLOGY, DHAKA

L-4/T-1 B. Sc. Engineering Examinations 2012-2013

Sub : **IPE 403** (Project and Environmental Management)

Full Marks: 210

Time : 3 Hours

USE SEPARATE SCRIPTS FOR EACH SECTION

The figures in the margin indicate full marks.

SECTION – AThere are **FOUR** questions in this section. Answer any **THREE**.

1. (a) Piecemeal system can never allow a project to be successful — discuss. (5)
- (b) Top-down and Bottom-up are two different cost estimation methods in project budgeting. However, Iterative budget supersedes both — how? (8)
- (c) "Project manager can be termed as "Conflict manager" — justify with example. (7)
- (d) For the following task table, find all possible crash times and corresponding costs for a project: (15)

Activity	Predecessor	Duration		Cost	
		N	C	N	C
a	—	3	2	70	70
b	a	4	2	40	100
c	a	3	1	30	70
d	b	4	1	50	150
e	b,c	2	2	35	35
f	d,e	5	3	60	100

2. (a) What is "Pareto-optimal solution"? How can you relate this with "Win-Win" situation? (4)
- (b) Type of project is one of the main factors in selecting appropriate structure — discuss with example for functional and dedicated structure. (6)
- (c) Briefly explain five different elements of a project plan. (10)
- (d) For the following activity table, obtain a schedule with constraint manpower requirements (maximum 20): (15)

Activity	Duration (day)	Manpower Requirement
1-2	5	12
1-3	8	10
2-3	7	8
2-4	6	12
3-4	4	10
3-5	9	10

IPE 403/IPE

3. (a) Discuss three main reasons for which project crashing is necessary. (9)
- (b) Out of four different frequencies of data collection for monitoring purpose, "random" is the worst — explain with example. (6)
- (c) How can you distinguish Gantt chart from network technique based on user application? (5)
- (d) For the following table, draw the network diagram, calculate project duration, find the critical path and calculate total slack time for each task: (15)

Task	Follower	Duration (days)		
		Optimistic	Most likely	Pessimistic
a	—	12	14	17
b	a	5	6	8
c	a	7	9	10
d	b, c	10	13	15
e	c, d	8	8	9
f	e	9	11	12
g	f, e	6	8	10
h	f, g	11	13	14
i	h	4	5	7

4. (a) Do you think "post control" can be applicable to the current project? How? (5)
- (b) Describe cybernetic control mechanisms in project control. (8)
- (c) Briefly explain the effect of multicultural communication for project success. (5)
- (d) Elaborate "Linear Responsibility Chart" with example. (5)
- (e) For the following cash flow table, find the best suitable project of the two to invest based on NPV and Discounted PBP (12% discount rate): (12)

Year	Project A	Project B
0	-2,00,000	-2,00,000
1	40,000	20,000
2	40,000	30,000
3	50,000	60,000
4	60,000	70,000
5	50,000	70,000
6	40,000	50,000

Explain the logic behind your selection.

IPE 403/IPE

SECTION – B

There are **FOUR** questions in this section. Answer any **THREE**.

5. (a) Describe an international convention on conservation and sustainable development of wetlands. (20)
- (b) The GHG emission targets, set under Kyoto Protocol expired in 2013, which was extended later on. Write a short note on this extension process. (15)
6. (a) Write a short note on clauses, schedules and forms, mentioned under ECR, 1997. (20)
- (b) What are Hazardous Air Pollutants (HAPs)? (15)
7. (a) Write down the background (history) of ISO14000EMS? (15)
- (b) What are the major clauses of ISO14000EMS? (15)
- (c) What is "region of mixing"? (5)
8. (a) For any kind of project, five or six different types of project feasibility studies need to be done based on government or private ownership. Prepare a project proposal report for a real life project with all these studies to get funding approval from a bank. (25)
- (b) Briefly explain the special demand requirements for a person to be a project manager. (10)
-