

M. H. Khan
7.12.14

L-4/T-1/CHE

Date : 07/12/2014

BANGLADESH UNIVERSITY OF ENGINEERING AND TECHNOLOGY, DHAKA

L-4/T-1 B. Sc. Engineering Examinations 2012-2013

Sub : CHE 403 (Process Control)

Full Marks: 210

Time : 3 Hours

USE SEPARATE SCRIPTS FOR EACH SECTION

The figures in the margin indicate full marks.

SECTION - A

There are **FOUR** questions in this section. Answer any **THREE**.

1. (a) Draw proper P&I diagram of the following processes (18)

(i) Reactants enter a jacketed CSTR where a reaction takes place and the products exit. The reactor is cooled via a coolant water stream. The temperature inside the reactor vessel is monitored with a temperature controller (also contained in the controller is a sensor, indicator and transmitter), which electrically controls a valve. The valve can alter the flowrate of the coolant water stream, thereby controlling the temperature inside the reactor. A pressure controller is also present which feeds back to an inlet valve. The reaction occurs most likely in gas phase and if the CSTR becomes too full (high pressure) the inlet valve will close.

(ii) A storage tank is filled with condensed products formed via the CSTR in above question. The tank contains a level controller at a set point on the top of the tank. If this tank were to fill, materials would get clogged up in the reactor. Therefore, if the tank reaches 90% of its total capacity, the level controller will send an electric signal, which opens an emergency drainage line located at the bottom of the tank. The level controller will also activate an alarm alerting plant engineers that there is a problem with the storage tank. Finally, the level controller will also close the inlet valve to the storage tank.

(b) Why do we use Laplace Transform for analyzing process control systems? Elaborate on your answer. (10)

(c) Apply the initial and final value theorems to the following transfer function, (7)

$$\frac{(S+1)}{S(S+2)(S+3)} e^{-0.05s}$$

2. (a) Describe the steps that are followed to develop dynamic models for process control purpose. (10)

(b) An exothermic reaction, $A \rightarrow 2B$, takes place adiabatically in a stirred-tank reactor. This liquid reaction occurs at constant volume in a 1000-gal reactor. The reaction can be considered to be first order and irreversible with the rate constant given by (25)

$$K = 2.4 \times 10^{15} e^{-20000/T} (\text{min}^{-1}), \text{ where } T \text{ is in } ^\circ\text{R}.$$

Contd P/2

CHE 403/CHE

Contd... Q. No. 2(b)

Using the information below, derive a transfer function relating the exit temperature T to the inlet concentration C_{Ai} . State all assumptions that you make.

Available information

- (i) Nominal steady state conditions are:

$$\bar{T} = 150^\circ F, \bar{C}_{Ai} = 0.8 \text{ mol/ft}^3$$

$$\bar{q} = 20 \text{ gal/min} = \text{flow in and out of the reactor}$$

- (ii) Physical property data for the mixture at steady state:

$$C = 0.8 \frac{BTU}{lb^\circ F}, \rho = 52 \text{ lb/ft}^3, -\Delta H_R = 500 \text{ kJ/mol}$$

3. (a) A step change from 15 to 31 psi in actual pressure results in the measured response from a pressure indicating element shown in Figure for Question 3(a). Assuming second order dynamics, calculate all important parameters and write an approximate transfer function in the form.

(18)

$$\frac{R'(s)}{P'(s)} = \frac{k}{\tau^2 s^2 + 2\xi\tau s + 1}$$

where, R' is the instrument output deviation (mm), P' is the actual pressure deviation (psi).

- (b) For the process described by the exact transfer function

(17)

$$G(s) = \frac{5}{(10s+1)(4s+1)(s+1)(0.2s+1)}$$

Use Skogestad's method to derive two approximate models

- (i) A first order-plus-time-delay model.
 (ii) A second-order-plus-time-delay model in the form

$$G(s) = \frac{ke^{-\theta s}}{(\tau_1 s + 1)(\tau_2 s + 1)}$$

4. (a) A heat exchanger is used to heat and glycol solution with a hot oil. A thermocouple is placed 3 m downstream from the outlet of the heat exchanger. Data from a unit step test in Q' on the complete system are shown in Figure for Question 4(a). Where T' is the outlet temperature deviation. Q' is the hot oil flow rate deviation. Using Smith's method calculate the time constants of this process from the step response and develop the overall transfer function. For required information see Figure-2 for Question 4(a).

(17)

CHE 403/CHE

Contd... Q. No. 4

(b) A process instrumentation diagram of a flash drum is shown in Figure for Question 4(b). Steam is condensed in a steam coil to vaporize a portion of the liquid feed, and the liquid product is removed by a pump. There are control valves for the steam flow, vapor product, liquid product, feed flow, and the steam chest (which allows the steam chest to be rapidly evacuated in emergency situations). Determine which of the five valves should be fail-close (F/C) or fail-open (F/O) for safe operation, for each of three cases: **(18)**

- (i) The safest conditions are achieved by the lowest temperature and pressure in the flash vessel.
- (ii) Vapor flow to downstream equipment can cause a hazardous situation.
- (iii) Liquid flow to downstream equipment can cause a hazardous situation.

SECTION - B

There are **FOUR** questions in this section. Answer any **THREE**.

Symbols have their usual meanings.

- 5. (a) Describe general guidelines for tuning flow loops and level control loops. **(7)**
- (b) Starting from the equation of an analog PID controller, derive the velocity form of a digital PID controller. State three advantages of velocity form over position form of PID controllers. **(8)**
- (c) Describe the Ziegler-Nichols method of tuning PID controllers. What are its characteristics? *disadvantages?* **(10)**
- (d) The equation of PI controller is given by **(10)**

$$p'(t) = K_c e(t) + \frac{K_c}{\tau_I} \int_0^t e(t) dt$$

The expression of $e(t)$ for a particular case is given by

$$e(t) = \begin{cases} 2 & , t \geq 0 \\ 0 & , t < 0 \end{cases}$$

For this case, if $p'(t)$ is given by Fig. 5(d), find value of K_c and τ_I .

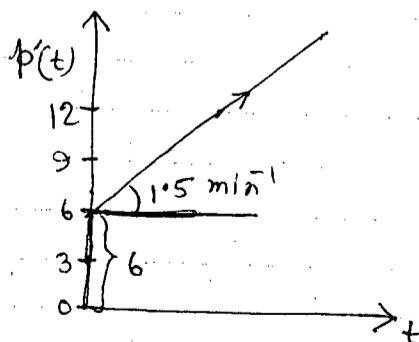
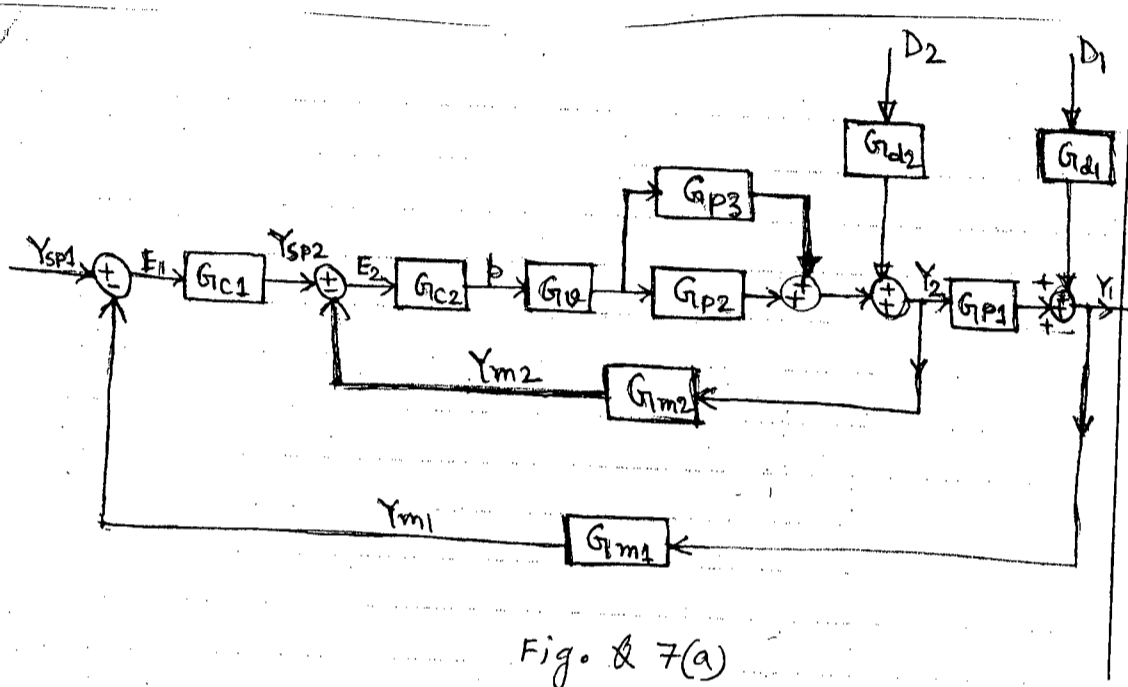

Fig: 5(d)

CHE 403/CHE

6. (a) Write short notes with examples on (7×3=21)
 (i) Cascade Control
 (ii) Selective Control
 (iii) Feedforward Control
 (b) What do you understand by a lag-dominant process? How would you design PI controllers for such processes? (2+12=14)
7. (a) Consider the block diagram given in Fig. Q 7(a). Find the relation Y_1/Y_{sp1} . (20)



- (b) For Fig. Q 7(a), the following information are given: (15)

$$G_v = \frac{5}{s+1}, \quad G_{p1} = \frac{4}{(4s+1)(2s+1)}, \quad G_{p2} = G_{p3} = 1$$

$$G_{d2} = 1, \quad G_{m1} = 0.05, \quad G_{m2} = 0.2, \quad G_{d1} = \frac{1}{3s+1}$$

$$G_{c1} = K_{c1} \text{ and } G_{c2} = K_{c2} = 4$$

Find the stability limit or maximum values of k_{c1} using Routh array.

8. (a) The Bode plot of the open loop transfer function of a low-order process, $G_l = G_p G_m G_T G_v$ is shown in Fig. Q 8(a). Find the following:
- (i) The steady-state gain. (2)
 - (ii) The cross-over frequency. (2)
 - (iii) The ultimate gain, K_{cu} . (3)
 - (iv) The gain margin and phase margin. (5)
 - (v) How much additional delay, the process can tolerate before it becomes unstable? (8)
- (b) What do understand by reset wind-up? Explain. (10)
- (c) Sketch the Bode diagram of a pure time delay process. (5)

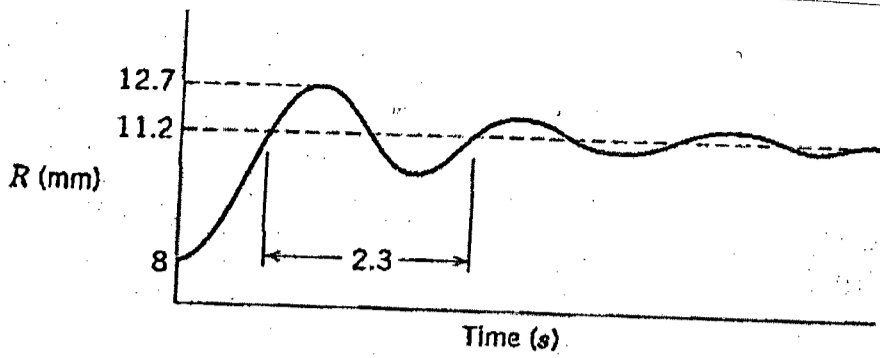
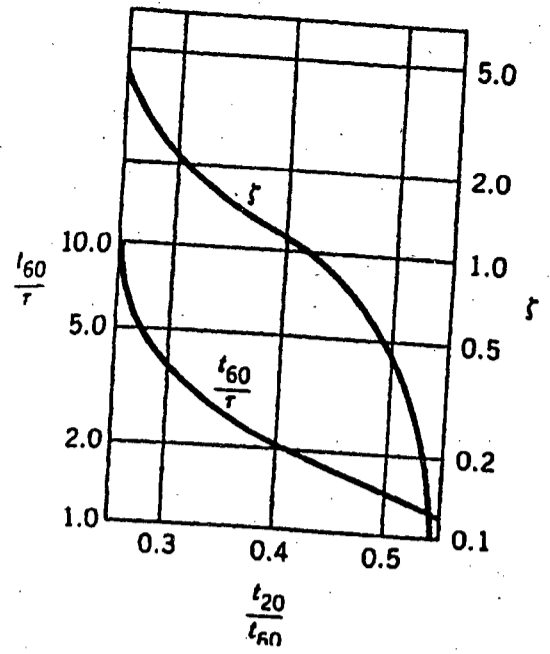

Figure for Question 3 (a)



Smith's method:
relationship of ζ and τ to t_{20} and t_{60} .

Figure - 2 for Question 4(a)

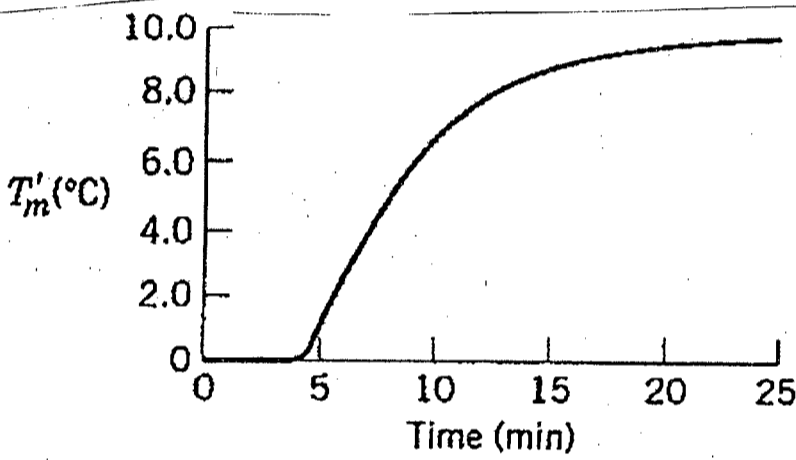

Figure - 4(a)

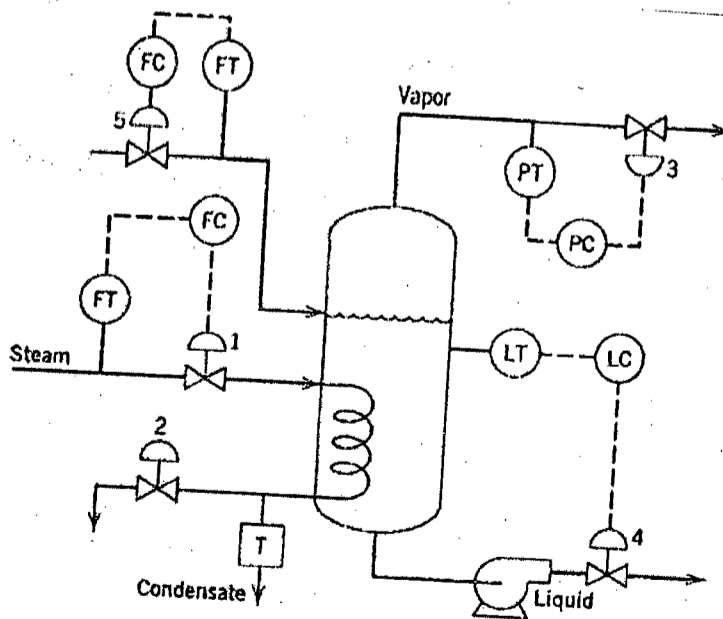

Figure for Question 4(b)

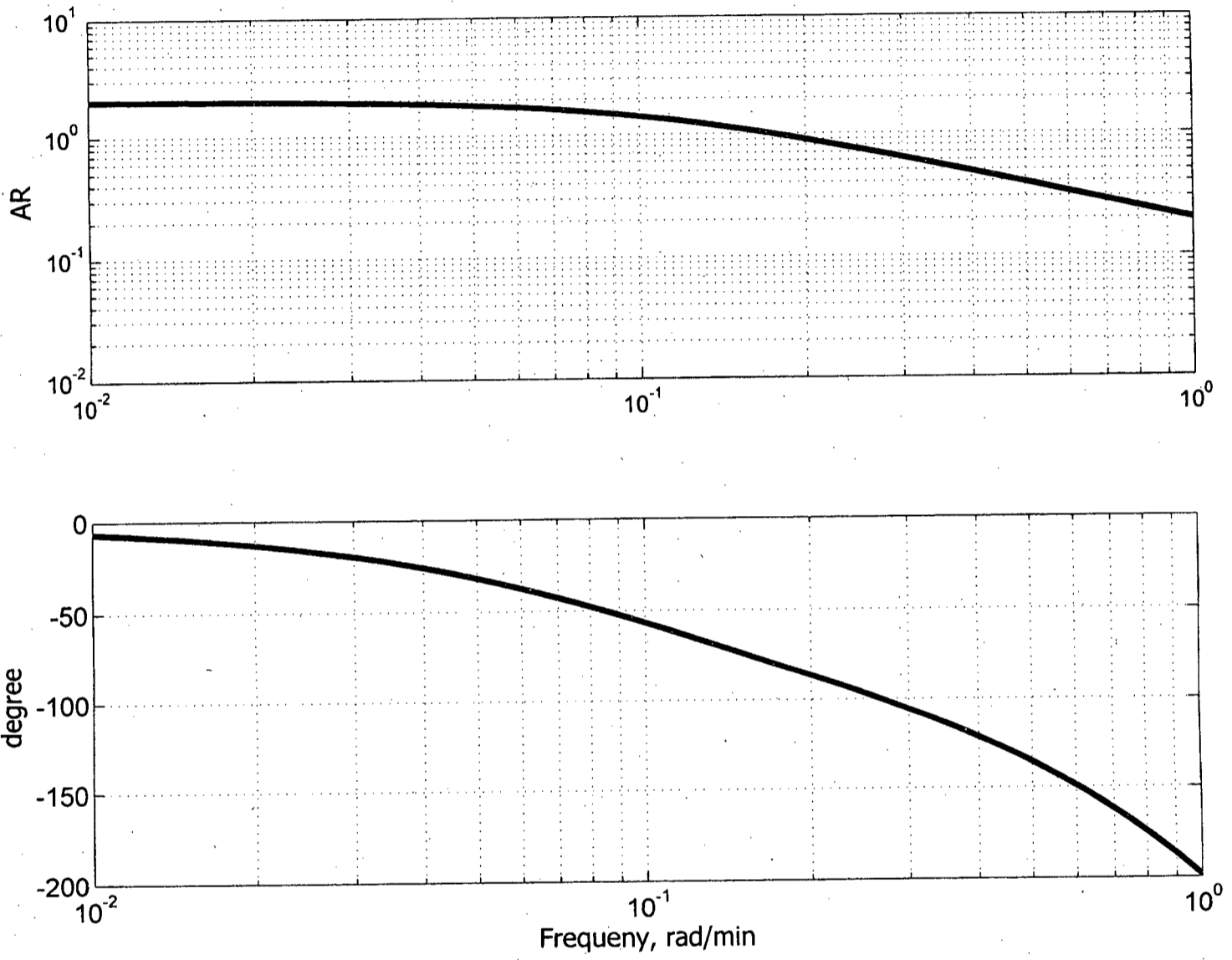

Fig. Q.8(a)

SECTION – A

There are **FOUR** questions in this section. Answer any **THREE**.

Notations indicate their usual meanings.

Assume reasonable value if additional data is required.

1. (a) Explain briefly the followings: (4×2=8)
- (i) Reaction order
- (ii) Reaction rate constant.
- (b) List the techniques used for the interpretation of reaction rate data. (5)
- (c) What would be your decision if there is a deviation from linearity (by integral method) with an assumed order of a reaction? (5)
- (d) Svirbley and Rath have reported the following data for the reaction between HCN and C₃H₇CHO in aqueous solution at 25°C. (17)

Time, t (sec)	HCN (moles/m ³)	C ₃ H ₇ CHO (moles/m ³)
166.8	99.0	56.6
319.8	90.6	48.2
490.2	83.0	40.6
913.8	70.6	28.2
1188.0	65.3	22.9
α	42.4	0

Determine the order of the reaction and the reaction rate constant.

2. (a) What do you understand by reaction mechanism? Write down the preliminary criteria for testing a proposed reaction mechanism. (4+6)
- (b) State the four basic assumptions involved in the derivation of a rate expression from a proposed reaction mechanism. (10)
- (c) The following mechanism has been proposed for the oxidation of nitric oxide, (15)
- $$NO + \frac{1}{2}O_2 \rightarrow NO_2.$$

CHE 401/CHE

Contd... Q. No. 2(c)

Mechanism:

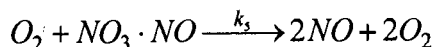
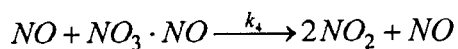
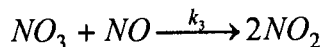
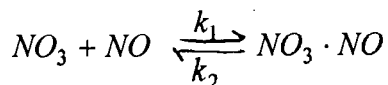
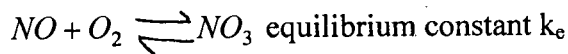

Derive a rate expression that is consistent with this mechanism.

3. (a) For the opposing first order reaction $A \xrightleftharpoons[k_2]{k_1} B$ find the expression $\frac{\varepsilon^*}{\varepsilon_e} = 1 - e^{-(k_1+k_2)t}$. (12)

(b) Define relaxation time for a reversible reaction. Deduce the expression of relaxation

time for first order reaction, $A \xrightleftharpoons[k_1]{k_1} B$. (15)

(c) Write down the differential equation for the following cases: (4+4)

- (i) Reversible first order parallel reaction
- (ii) Irreversible first order parallel reaction.

4. (a) For the set of first order consecutive reactions (20)

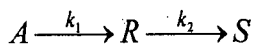

Determine the expression for the maximum concentration of R that can be obtained.

How long does it take to achieve this maximum for (i) $k_1 \neq k_2$ and (ii) $k_1 = k_2$?

(b) A coupled enzyme assay system may be represented as (15)

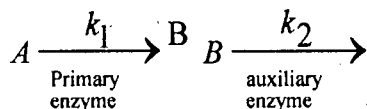

If the first reaction is regarded as zero-order irreversible, and the second reaction is first-order in the product B, determine the time-dependent behavior of the concentration of species B if no B is present initially. How long does it take to reach 98% of the steady-state value if $k_1 = 0.833 \text{ mole/m}^3\text{-ksec}$ and $k_2 = 0.767 \text{ sec}^{-1}$? What is this steady-state value?

CHE 401/CHE

SECTION – B

There are **FOUR** questions in this section. Answer any **THREE**.

5. (a) Discuss the role of physical and chemical characterization in assessing the properties of heterogeneous catalyst. (6)
- (b) Compare the Langmuir Adsorption Isotherm with the BET Isotherm. (6)
- (c) Point out the distinguished features of heterogeneous catalyst preparation methods. Discuss the role of different components of heterogeneous catalysts. (6+8=14)
- (d) Explain the following terms: (9)
- (i) Intrinsic and global rates
 - (ii) Poisoning of heterogeneous catalysts.
 - (iii) Chemical and Physical Adsorption.

6. (a) Write down the different forms of rate expressions for heterogeneous catalytic reactions limited by the rates of chemical processes. (3)
- (b) Some investigators have studied the decomposition of ammonia over a heated platinum filament at 1200°C. The reaction stoichiometry is (15)

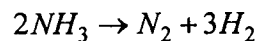

Initially, pure NH₃ was present in the reaction vessel. The reactor volume is a constant. The data presented below are representative of the kinetics of the reaction.

Time, (t (sec))	Total pressure (kPa)
0	26.7
60	34.1
240	38.5
720	42.7

It has been postulated that the rate expression for the reaction is of the form $r = k \frac{P_{NH_3}}{P_{H_2}}$.

Is the experimental data consistent with this rate expression? If so, what is the value of the rate constant?

- (c) What are the points to be considered in designing a heterogeneous reactors? (5)
- (b) Discuss the advantages and disadvantages of the reactors used in chemical industries. (12)

CHE 401/CHE

7. (a) Explain the impact of material and energy balances on design of industrial reactors. (8)
- (b) Discuss the graphical approach to the analysis of batteries of stirred tank reactors operating at steady state. (10)
- (c) The rate of a chemical reaction is given by $r = k C_A^n$ where, $r = \frac{1}{V} \frac{d\xi_1}{dt}$. (17)

If 90% of the reactant A is converted to products in a reactor, and if one obtains a second reactor that is one half the size of the first, determine the increase in feed capacity that results from the following types of operations:

- (i) $n = 1$ two plug flow reactors in series
- (ii) $n = 1$ two plug flow reactors in parallel.

Assume that the exit composition from the last reactor remains unchanged in all cases and that none of A has been converted to products prior to entering the reactor. Do not assume $\delta = 0$. Obtain a general solution. In series operation the small reactor precedes the large reactor in the sequence.

8. (a) The total volume of a cascade of equalized CSTR's approach the volume of plug flow reactor as the number of reactors is increased for the same overall conversion if the reaction is assumed to be first order — Explain. (10+3=13)
- (b) Highlight the main features of one and two dimensional pseudo homogeneous models of fixed bed reactors. (10+3=13)
- (c) Explain the following terms: (9)
- (i) Bulk and Knudsen diffusion
- (ii) Effectiveness factor and Effective diffusivity
- (iii) Thiele Modulus
-

BANGLADESH UNIVERSITY OF ENGINEERING AND TECHNOLOGY, DHAKA

L-4/T-1 B. Sc. Engineering Examinations 2012-2013

Sub : **CHE 453** (Transport Phenomena)

Full Marks: 210

Time : 3 Hours

USE SEPARATE SCRIPTS FOR EACH SECTION

The figures in the margin indicate full marks.

Symbols indicate their usual meaning. Assume reasonable value for any missing data.

SECTION - AThere are **FOUR** questions in this section. Answer any **THREE**.

1. (a) Estimate the viscosity of N_2 at $68^\circ F$ and 1000 psig. The critical pressure for N_2 is 33.5 atm and critical temperature is 126.2 K. The viscosity at the critical condition can be evaluated from the following correlation: (10)

$$\mu_c = 7.70M^{1/2} p_c^{2/3} T_c^{-1/6}$$

- (b) Calculate the required torque to turn the shaft in the friction bearing as shown in Fig. 1(b). You may assume the length of the bearing surface on the shaft is 2 inch, the shaft is turning at 200 rpm, the viscosity of the lubricant is 200 cp and density is $50 \text{ lb}_m \text{ft}^{-3}$, (15)

(i) State the assumption and find the momentum and velocity distribution, in the lubricant film

(ii) Calculate the required torque in $\text{lb}_f\text{-ft}$ to turn the shaft

- (c) A cylindrical rod is being moved with a velocity in system showing in Fig. 1(c). The rod and the cylinder are coaxial. Find the steady state velocity distribution. (10)

2. (a) Develop the Navier-Stokes equation from the following form of equation of motion (x-component) by making appropriate assumption, (10)

$$\rho \frac{Dv_x}{Dt} = -\frac{\partial P}{\partial x} - \left(\frac{\partial \tau_{xx}}{\partial x} + \frac{\partial \tau_{yx}}{\partial y} + \frac{\partial \tau_{zx}}{\partial z} \right) + \rho g_x$$

- (b) Find the dimensionless form of the Navier-Stokes equation. (10)

- (c) Determine the velocity distribution of two coaxial cylinders of radii R and kR , ($0 \leq k \leq 1$) rotating at angular velocity Ω_0 and Ω_1 respectively (in opposite direction). Assume that the space between the cylinders is filled with an incompressible fluid in laminar flow. (15)

3. (a) Distinguish between laminar and turbulent flow. Draw the laminar and turbulent velocity distributions for tube flow. (10)

- (b) Define the term "time-smooth velocity" and "eddy viscosity" for turbulent flow. (8)

CHE 453/CHE

Contd... Q. No. 3

(c) Discuss Von Karman's equation of momentum flux for turbulent flow. Which relationship of momentum flux you should use to calculate velocity profile in the viscous sub-layer and in the buffer region? (7)

(d) Derive the velocity distribution (near the wall) for flow through a cylindrical tube using appropriate semi empirical expression for the Reynolds stresses. (10)

4. (a) What are conditions required to be maintained between two systems to make it dynamically similar? (5)

(b) State the comparison of momentum, mass and heat transport process in laminar region. (8)

(c) Explain Taylor-Prandtl analogy for heat and momentum transport and show that (22)

$$St_h = \frac{\frac{1}{2} C_f}{1 + \frac{u_L}{u_m} (Pr-1)}$$

Extend the analogy for mass transfer in turbulent flow and find the Taylor-Prandtl analogy for mass transfer.

SECTION - B

There are **FOUR** questions in this section. Answer any **THREE**.

5. (a) Consider the diffusion system shown in the figure for Question 5(a). Liquid A is evaporating into gas B and liquid level is assumed to be maintained at $Z = Z_1$. At the top of the tube a stream of gas mixture A-B flows past slowly. The entire system is presumed to be held at constant temperature and pressure. Develop expressions for concentration profiles for component A and B within the tube and rate of mass transfer at the gas-liquid interface. (20)

(b) Chlorine is being absorbed from a gas in a small experimental wetted wall tower, as shown in the figure for Question 5(b). The absorbing fluid is water, which is moving with an average velocity of 17.7 cm/sec. What is the absorption rate in g-moles/hr if diffusivity $D_{Cl_2-H_2O} = 1.26 \times 10^{-5}$ cm²/sec in the liquid phase and if the saturation concentration of chlorine in water is 0.823 gm Cl₂ per 100 gm of water. The dimensions of the column are given in the figure. Ignore the chemical reaction between Cl₂ and H₂O and velocity variation within the liquid film.

CHE 453/CHE

6. (a) Derive the Bridgman's equation of thermal conductivity of liquids. Write down the assumption considered in deriving the equation. (10)

(b) The density of liquid CCl_4 at 20°C and 1 atm is 1.595 gm/cm^3 , and its compressibility $\frac{1}{\rho} \left(\frac{\partial \rho}{\partial p} \right)_T$ is $90.7 \times 10^{-6}/\text{atm}$. What is the thermal conductivity? (12)

(c) Write down the mathematical formulation of one-dimensional, steady-state heat conduction for a hollow sphere with constant thermal conductivity in the region $a \leq r \leq b$, when heat is supplied to the sphere at a rate of $q_o \text{ W/m}^2$ from the boundary surface at $r = b$ into a medium inside the sphere at zero degree temperature with a heat transfer coefficient h . (13)

7. A heated sphere of radius R is suspended in a large, motionless body of fluid. It is desired to study the heat conduction in the fluid surrounding the sphere. It is assumed in this problem that free convection effects can be neglected.

(a) Setup the differential equation describing the temperature T in the surrounding fluid as a function of r , the distance from the center of the sphere. The thermal conductivity of the fluid k is constant. (13)

(b) Integrate the differential equation and use the boundary conditions (12)

B.C. 1: at $r = R, T = T_R$

B.C. 2: at $r = \infty, T = T_\infty$

To determine the constants of integration.

(c) From the temperature profile, obtain an expression for the heat flux at the surface. (10)

8. Consider two concentric porous spherical shells of radii kR and R , as shown in the figure for Question No. 8. The inner surface of the outer one is at $T = T_1$, and the outer surface of the inner one is to be maintained at a lower temperature, T_k . Dry air at temperature $T = T_k$ is blown outward radially from the inner shell into the intervening space and out through the outer shell. Develop an expression for the required rate of heat removal from the inner sphere as a function of the mass rate of flow of gas. Assume steady laminar flow, and low gas velocity. (35)

Figures and Tables

Subject: CHE 453 (Transport Phenomena)

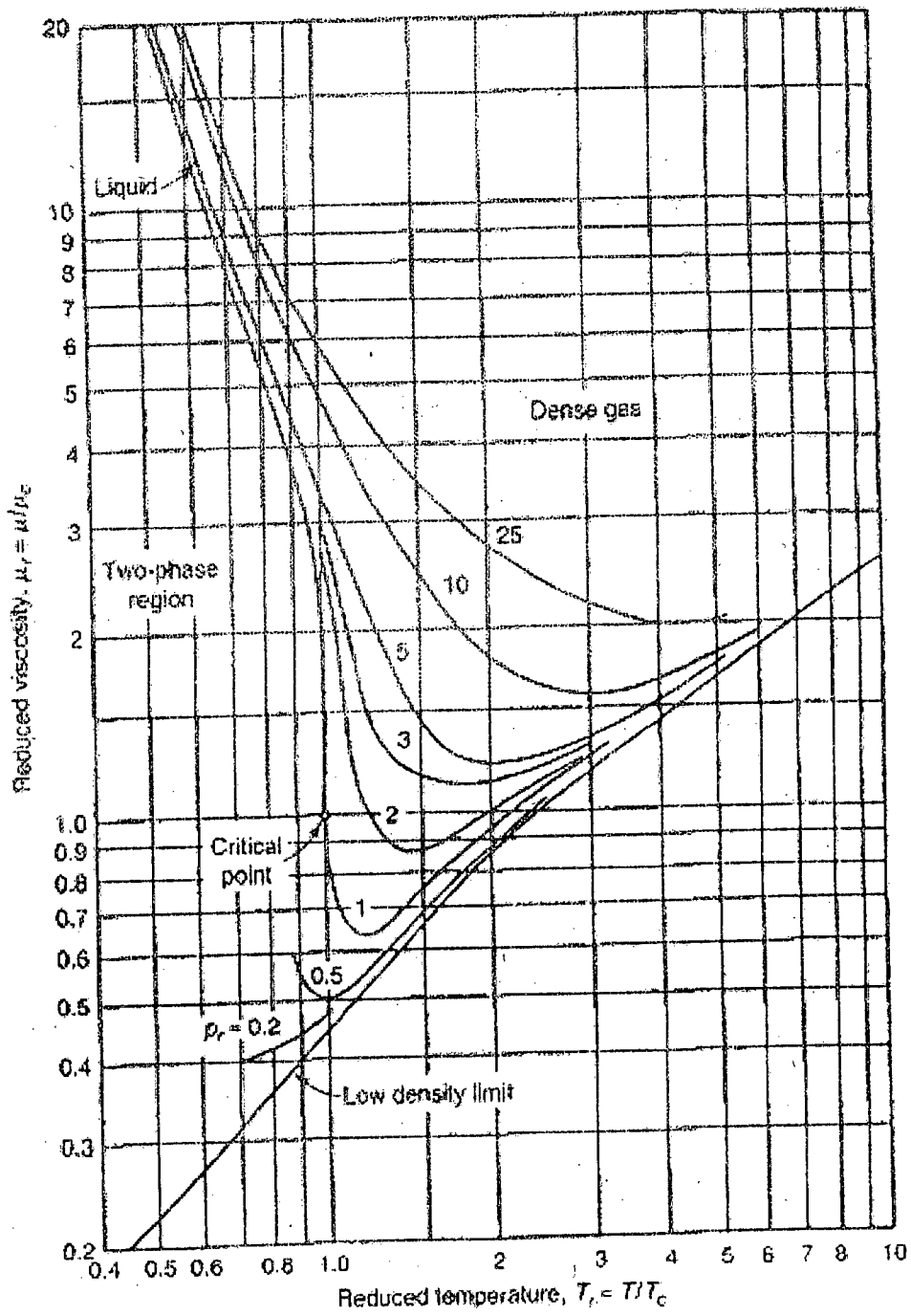

Fig. for 1(a): Reduced viscosity as function of reduced temperature and pressure

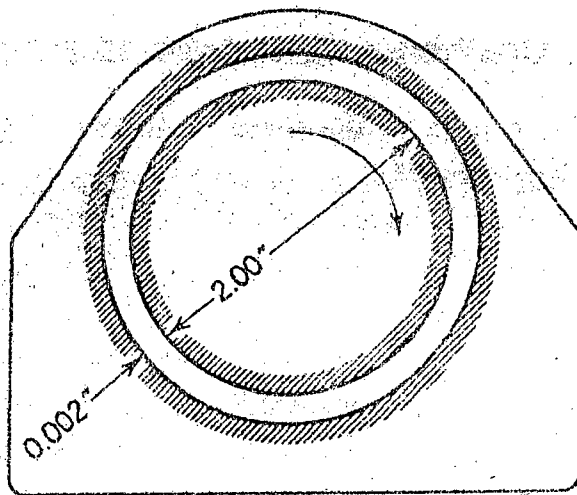

Fig. for 1(b): Friction bearing

TABLE 3.4-5
COMPONENTS OF THE STRESS TENSOR FOR NEWTONIAN FLUIDS
IN RECTANGULAR COORDINATES (x, y, z)

$\tau_{xx} = -\mu \left[2 \frac{\partial v_x}{\partial x} - \frac{2}{3} (\nabla \cdot v) \right]$	(A)
$\tau_{yy} = -\mu \left[2 \frac{\partial v_y}{\partial y} - \frac{2}{3} (\nabla \cdot v) \right]$	(B)
$\tau_{zz} = -\mu \left[2 \frac{\partial v_z}{\partial z} - \frac{2}{3} (\nabla \cdot v) \right]$	(C)
$\tau_{xy} = \tau_{yx} = -\mu \left[\frac{\partial v_x}{\partial y} + \frac{\partial v_y}{\partial x} \right]$	(D)
$\tau_{yz} = \tau_{zy} = -\mu \left[\frac{\partial v_y}{\partial z} + \frac{\partial v_z}{\partial y} \right]$	(E)
$\tau_{zx} = \tau_{xz} = -\mu \left[\frac{\partial v_z}{\partial x} + \frac{\partial v_x}{\partial z} \right]$	(F)
$(\nabla \cdot v) = \frac{\partial v_x}{\partial x} + \frac{\partial v_y}{\partial y} + \frac{\partial v_z}{\partial z}$	(G)

TABLE 3.4-1
THE EQUATION OF CONTINUITY IN SEVERAL
COORDINATE SYSTEMS

Rectangular coordinates (x, y, z):	
$\frac{\partial \rho}{\partial t} + \frac{\partial}{\partial x}(\rho v_x) + \frac{\partial}{\partial y}(\rho v_y) + \frac{\partial}{\partial z}(\rho v_z) = 0$	(A)
Cylindrical coordinates (r, θ, z):	
$\frac{\partial \rho}{\partial t} + \frac{1}{r} \frac{\partial}{\partial r}(\rho r v_r) + \frac{1}{r} \frac{\partial}{\partial \theta}(\rho v_\theta) + \frac{\partial}{\partial z}(\rho v_z) = 0$	(B)
Spherical coordinates (r, θ, ϕ):	
$\frac{\partial \rho}{\partial t} + \frac{1}{r^2} \frac{\partial}{\partial r}(\rho r^2 v_r) + \frac{1}{r \sin \theta} \frac{\partial}{\partial \theta}(\rho v_\theta \sin \theta) + \frac{1}{r \sin \theta} \frac{\partial}{\partial \phi}(\rho v_\phi) = 0$	(C)

Table for Qws. No. 2

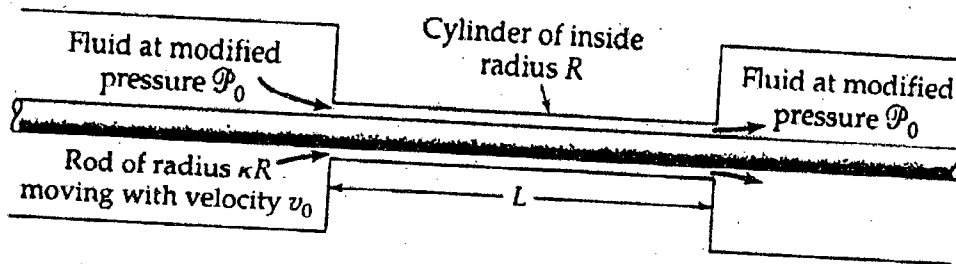

Fig. 1.(c) Annular Flow with inner Cylinder Moving Axially

The Equations of Change in Curvilinear Coordinates

TABLE 3.4-3

THE EQUATION OF MOTION IN CYLINDRICAL COORDINATES (r, θ, z)

In terms of τ :

$$r\text{-component}^a \quad \rho \left(\frac{\partial v_r}{\partial t} + v_r \frac{\partial v_r}{\partial r} + \frac{v_\theta}{r} \frac{\partial v_r}{\partial \theta} - \frac{v_\theta^2}{r} + v_z \frac{\partial v_r}{\partial z} \right) = - \frac{\partial p}{\partial r} - \left(\frac{1}{r} \frac{\partial}{\partial r} (r\tau_{rr}) + \frac{1}{r} \frac{\partial \tau_{r\theta}}{\partial \theta} - \frac{\tau_{\theta\theta}}{r} + \frac{\partial \tau_{rz}}{\partial z} \right) + \rho g_r \quad (A)$$

$$\theta\text{-component}^b \quad \rho \left(\frac{\partial v_\theta}{\partial t} + v_r \frac{\partial v_\theta}{\partial r} + \frac{v_\theta}{r} \frac{\partial v_\theta}{\partial \theta} + \frac{v_r v_\theta}{r} + v_z \frac{\partial v_\theta}{\partial z} \right) = - \frac{1}{r} \frac{\partial p}{\partial \theta} - \left(\frac{1}{r^2} \frac{\partial}{\partial r} (r^2 \tau_{r\theta}) + \frac{1}{r} \frac{\partial \tau_{\theta\theta}}{\partial \theta} + \frac{\partial \tau_{\theta z}}{\partial z} \right) + \rho g_\theta \quad (B)$$

$$z\text{-component} \quad \rho \left(\frac{\partial v_z}{\partial t} + v_r \frac{\partial v_z}{\partial r} + \frac{v_\theta}{r} \frac{\partial v_z}{\partial \theta} + v_z \frac{\partial v_z}{\partial z} \right) = - \frac{\partial p}{\partial z} - \left(\frac{1}{r} \frac{\partial}{\partial r} (r\tau_{rz}) + \frac{1}{r} \frac{\partial \tau_{\theta z}}{\partial \theta} + \frac{\partial \tau_{zz}}{\partial z} \right) + \rho g_z \quad (C)$$

In terms of velocity gradients for a Newtonian fluid with constant ρ and μ :

$$r\text{-component}^a \quad \rho \left(\frac{\partial v_r}{\partial t} + v_r \frac{\partial v_r}{\partial r} + \frac{v_\theta}{r} \frac{\partial v_r}{\partial \theta} - \frac{v_\theta^2}{r} + v_z \frac{\partial v_r}{\partial z} \right) = - \frac{\partial p}{\partial r} + \mu \left[\frac{\partial}{\partial r} \left(\frac{1}{r} \frac{\partial}{\partial r} (rv_r) \right) + \frac{1}{r^2} \frac{\partial^2 v_r}{\partial \theta^2} - \frac{2}{r^2} \frac{\partial v_\theta}{\partial \theta} + \frac{\partial^2 v_r}{\partial z^2} \right] + \rho g_r \quad (D)$$

$$\theta\text{-component}^b \quad \rho \left(\frac{\partial v_\theta}{\partial t} + v_r \frac{\partial v_\theta}{\partial r} + \frac{v_\theta}{r} \frac{\partial v_\theta}{\partial \theta} + \frac{v_r v_\theta}{r} + v_z \frac{\partial v_\theta}{\partial z} \right) = - \frac{1}{r} \frac{\partial p}{\partial \theta} + \mu \left[\frac{\partial}{\partial r} \left(\frac{1}{r} \frac{\partial}{\partial r} (rv_\theta) \right) + \frac{1}{r^2} \frac{\partial^2 v_\theta}{\partial \theta^2} + \frac{2}{r^2} \frac{\partial v_r}{\partial \theta} + \frac{\partial^2 v_\theta}{\partial z^2} \right] + \rho g_\theta \quad (E)$$

$$z\text{-component} \quad \rho \left(\frac{\partial v_z}{\partial t} + v_r \frac{\partial v_z}{\partial r} + \frac{v_\theta}{r} \frac{\partial v_z}{\partial \theta} + v_z \frac{\partial v_z}{\partial z} \right) = - \frac{\partial p}{\partial z} + \mu \left[\frac{1}{r} \frac{\partial}{\partial r} \left(r \frac{\partial v_z}{\partial r} \right) + \frac{1}{r^2} \frac{\partial^2 v_z}{\partial \theta^2} + \frac{\partial^2 v_z}{\partial z^2} \right] + \rho g_z \quad (F)$$

^a The term $\rho v_\theta^2/r$ is the centrifugal force. It gives the effective force in the r -direction resulting from fluid motion in the θ -direction. This term arises automatically on transformation from rectangular to cylindrical coordinates; it does not have to be added on physical grounds. Two problems in which this term arises are discussed in Examples 3.5-1 and 3.5-2.

^b The term $\rho v_r v_\theta/r$ is the Coriolis force. It is an effective force in the θ -direction when there is flow in both the r - and θ -directions. This term also arises automatically in the coordinate transformation. The Coriolis force arises in the problem of flow near a rotating disk (see, for example, H. Schlichting, *Boundary-Layer Theory*, McGraw-Hill, New York (1955), Chapter 5, §10.

Table for Qns No: 2

The Equations of Motion for Nonisothermal Flow

TABLE 10.2-3
THE EQUATION OF ENERGY IN TERMS OF THE TRANSPORT PROPERTIES
(for Newtonian fluids of constant ρ and k)
(Eq. 10.1-25 with viscous dissipation terms included)

Rectangular coordinates:

$$\rho \hat{C}_p \left(\frac{\partial T}{\partial t} + v_x \frac{\partial T}{\partial x} + v_y \frac{\partial T}{\partial y} + v_z \frac{\partial T}{\partial z} \right) = k \left[\frac{\partial^2 T}{\partial x^2} + \frac{\partial^2 T}{\partial y^2} + \frac{\partial^2 T}{\partial z^2} \right] + 2\mu \left\{ \left(\frac{\partial v_x}{\partial x} \right)^2 + \left(\frac{\partial v_y}{\partial y} \right)^2 + \left(\frac{\partial v_z}{\partial z} \right)^2 \right\} + \mu \left\{ \left(\frac{\partial v_x}{\partial y} + \frac{\partial v_y}{\partial x} \right)^2 + \left(\frac{\partial v_x}{\partial z} + \frac{\partial v_z}{\partial x} \right)^2 + \left(\frac{\partial v_y}{\partial z} + \frac{\partial v_z}{\partial y} \right)^2 \right\} \quad (A)$$

Cylindrical coordinates:

$$\rho \hat{C}_p \left(\frac{\partial T}{\partial t} + v_r \frac{\partial T}{\partial r} + \frac{v_\theta}{r} \frac{\partial T}{\partial \theta} + v_z \frac{\partial T}{\partial z} \right) = k \left[\frac{1}{r} \frac{\partial}{\partial r} \left(r \frac{\partial T}{\partial r} \right) + \frac{1}{r^2} \frac{\partial^2 T}{\partial \theta^2} + \frac{\partial^2 T}{\partial z^2} \right] + 2\mu \left\{ \left(\frac{\partial v_r}{\partial r} \right)^2 + \left[\frac{1}{r} \left(\frac{\partial v_\theta}{\partial \theta} + v_r \right) \right]^2 + \left(\frac{\partial v_z}{\partial z} \right)^2 \right\} + \mu \left\{ \left(\frac{\partial v_\theta}{\partial z} + \frac{1}{r} \frac{\partial v_z}{\partial \theta} \right)^2 + \left(\frac{\partial v_z}{\partial r} + \frac{\partial v_r}{\partial z} \right)^2 + \left[\frac{1}{r} \frac{\partial v_r}{\partial \theta} + r \frac{\partial}{\partial r} \left(\frac{v_\theta}{r} \right) \right]^2 \right\} \quad (B)$$

Spherical coordinates:

$$\rho \hat{C}_p \left(\frac{\partial T}{\partial t} + v_r \frac{\partial T}{\partial r} + \frac{v_\theta}{r} \frac{\partial T}{\partial \theta} + \frac{v_\phi}{r \sin \theta} \frac{\partial T}{\partial \phi} \right) = k \left[\frac{1}{r^2} \frac{\partial}{\partial r} \left(r^2 \frac{\partial T}{\partial r} \right) + \frac{1}{r^2 \sin \theta} \frac{\partial}{\partial \theta} \left(\sin \theta \frac{\partial T}{\partial \theta} \right) + \frac{1}{r^2 \sin^2 \theta} \frac{\partial^2 T}{\partial \phi^2} \right] + 2\mu \left\{ \left(\frac{\partial v_r}{\partial r} \right)^2 + \left(\frac{1}{r} \frac{\partial v_\theta}{\partial \theta} + \frac{v_r}{r} \right)^2 + \left(\frac{1}{r \sin \theta} \frac{\partial v_\phi}{\partial \phi} + \frac{v_r}{r} + \frac{v_\theta \cot \theta}{r} \right)^2 \right\} + \mu \left\{ \left[r \frac{\partial}{\partial r} \left(\frac{v_\theta}{r} \right) + \frac{1}{r} \frac{\partial v_r}{\partial \theta} \right]^2 + \left[\frac{1}{r \sin \theta} \frac{\partial v_r}{\partial \phi} + r \frac{\partial}{\partial r} \left(\frac{v_\phi}{r} \right) \right]^2 + \left[\frac{\sin \theta}{r} \frac{\partial}{\partial \theta} \left(\frac{v_\phi}{\sin \theta} \right) + \frac{1}{r \sin \theta} \frac{\partial v_\theta}{\partial \phi} \right]^2 \right\} \quad (C)$$

Note: The terms contained in braces { } are associated with viscous dissipation and may usually be neglected, except for systems with large velocity gradients.

The Equations of Change for Nonisothermal Systems

TABLE 10.2-2
THE EQUATION OF ENERGY IN TERMS OF ENERGY AND MOMENTUM FLUXES
(Eq. 10.1-19)

Rectangular coordinates:

$$\rho \hat{C}_v \left(\frac{\partial T}{\partial t} + v_x \frac{\partial T}{\partial x} + v_y \frac{\partial T}{\partial y} + v_z \frac{\partial T}{\partial z} \right) = - \left[\frac{\partial q_x}{\partial x} + \frac{\partial q_y}{\partial y} + \frac{\partial q_z}{\partial z} \right] - T \left(\frac{\partial \rho}{\partial T} \right)_p \left(\frac{\partial v_x}{\partial x} + \frac{\partial v_y}{\partial y} + \frac{\partial v_z}{\partial z} \right) - \left\{ \tau_{xx} \frac{\partial v_x}{\partial x} + \tau_{yy} \frac{\partial v_y}{\partial y} + \tau_{zz} \frac{\partial v_z}{\partial z} \right\} - \left\{ \tau_{xy} \left(\frac{\partial v_x}{\partial y} + \frac{\partial v_y}{\partial x} \right) + \tau_{xz} \left(\frac{\partial v_x}{\partial z} + \frac{\partial v_z}{\partial x} \right) + \tau_{yz} \left(\frac{\partial v_y}{\partial z} + \frac{\partial v_z}{\partial y} \right) \right\} \quad (A)$$

Cylindrical coordinates:

$$\rho \hat{C}_v \left(\frac{\partial T}{\partial t} + v_r \frac{\partial T}{\partial r} + \frac{v_\theta}{r} \frac{\partial T}{\partial \theta} + v_z \frac{\partial T}{\partial z} \right) = - \left[\frac{1}{r} \frac{\partial}{\partial r} (r q_r) + \frac{1}{r} \frac{\partial q_\theta}{\partial \theta} + \frac{\partial q_z}{\partial z} \right] - T \left(\frac{\partial \rho}{\partial T} \right)_p \left(\frac{1}{r} \frac{\partial}{\partial r} (r v_r) + \frac{1}{r} \frac{\partial v_\theta}{\partial \theta} + \frac{\partial v_z}{\partial z} \right) - \left\{ \tau_{rr} \frac{\partial v_r}{\partial r} + \tau_{\theta\theta} \frac{1}{r} \left(\frac{\partial v_\theta}{\partial \theta} + v_r \right) + \tau_{zz} \frac{\partial v_z}{\partial z} \right\} - \left\{ \tau_{r\theta} \left[r \frac{\partial}{\partial r} \left(\frac{v_\theta}{r} \right) + \frac{1}{r} \frac{\partial v_r}{\partial \theta} \right] + \tau_{rz} \left(\frac{\partial v_z}{\partial r} + \frac{\partial v_r}{\partial z} \right) + \tau_{\theta z} \left(\frac{1}{r} \frac{\partial v_z}{\partial \theta} + \frac{\partial v_\theta}{\partial z} \right) \right\} \quad (B)$$

Spherical coordinates:

$$\rho \hat{C}_v \left(\frac{\partial T}{\partial t} + v_r \frac{\partial T}{\partial r} + \frac{v_\theta}{r} \frac{\partial T}{\partial \theta} + \frac{v_\phi}{r \sin \theta} \frac{\partial T}{\partial \phi} \right) = - \left[\frac{1}{r^2} \frac{\partial}{\partial r} (r^2 q_r) + \frac{1}{r \sin \theta} \frac{\partial}{\partial \theta} (q_\theta \sin \theta) + \frac{1}{r \sin \theta} \frac{\partial q_\phi}{\partial \phi} \right] - T \left(\frac{\partial \rho}{\partial T} \right)_p \left(\frac{1}{r^2} \frac{\partial}{\partial r} (r^2 v_r) + \frac{1}{r \sin \theta} \frac{\partial}{\partial \theta} (v_\theta \sin \theta) + \frac{1}{r \sin \theta} \frac{\partial v_\phi}{\partial \phi} \right) - \left\{ \tau_{rr} \frac{\partial v_r}{\partial r} + \tau_{\theta\theta} \left(\frac{1}{r} \frac{\partial v_\theta}{\partial \theta} + \frac{v_r}{r} \right) + \tau_{\phi\phi} \left(\frac{1}{r \sin \theta} \frac{\partial v_\phi}{\partial \phi} + \frac{v_r}{r} + \frac{v_\theta \cot \theta}{r} \right) \right\} - \left\{ \tau_{r\theta} \left(\frac{\partial v_\theta}{\partial r} + \frac{1}{r} \frac{\partial v_r}{\partial \theta} - \frac{v_\theta}{r} \right) + \tau_{r\phi} \left(\frac{\partial v_\phi}{\partial r} + \frac{1}{r \sin \theta} \frac{\partial v_r}{\partial \phi} - \frac{v_\phi}{r} \right) + \tau_{\theta\phi} \left(\frac{1}{r} \frac{\partial v_\phi}{\partial \theta} + \frac{1}{r \sin \theta} \frac{\partial v_\theta}{\partial \phi} - \frac{\cot \theta}{r} v_\phi \right) \right\} \quad (C)$$

Note: The terms contained in braces { } are associated with viscous dissipation and may usually be neglected, except for systems with large velocity gradients.

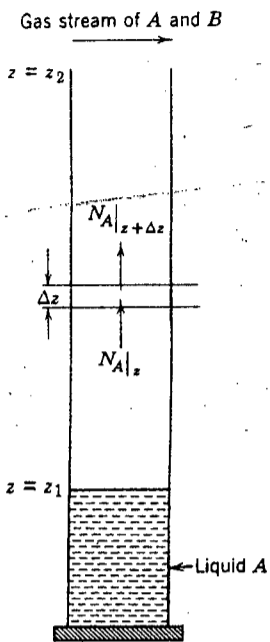

Figure for Question No. 5(a)

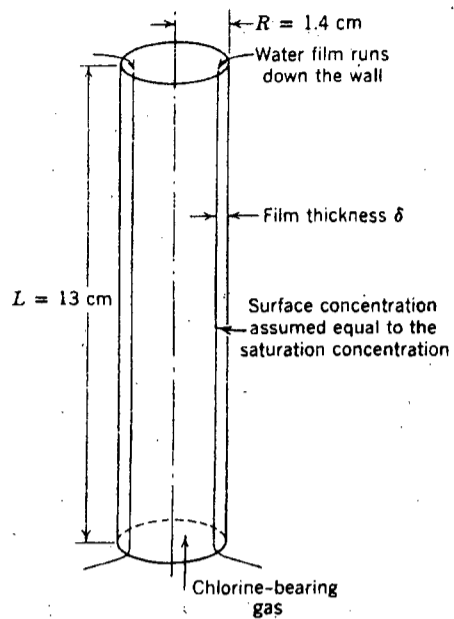

Figure for Question No. 5(b)

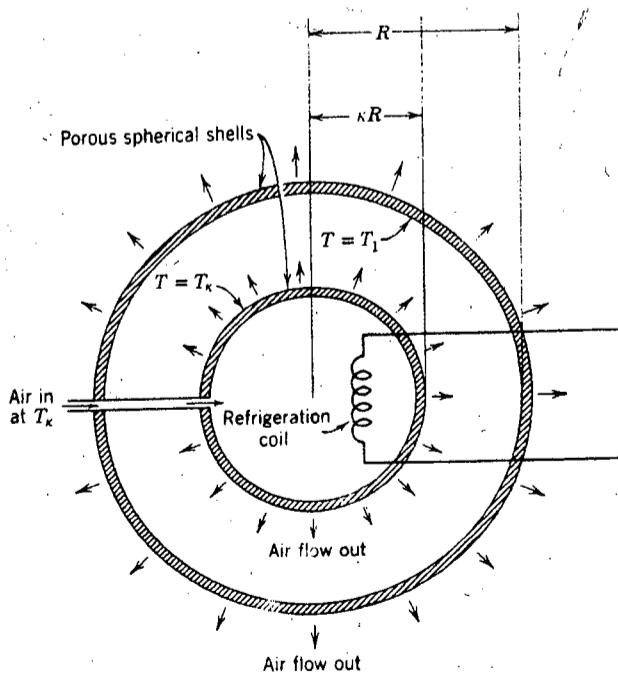

Figure for Question No. 8

checked
Modhusudan
20.01.15

L-4/T-1/CHE

Date : 05/01/2015

BANGLADESH UNIVERSITY OF ENGINEERING AND TECHNOLOGY, DHAKA

L-4/T-1 B. Sc. Engineering Examinations 2012-2013

Sub : **CHE 455** (Mathematical Models in Chemical Engineering)

Full Marks: 210

Time : 3 Hours

USE SEPARATE SCRIPTS FOR EACH SECTION

The figures in the margin indicate full marks.

SECTION - A

There are **FOUR** questions in this section. Answer any **THREE**.

1. (a) Consider a reaction $A \rightarrow B$ carried out in a batch reactor. The differential equation for species A is $\frac{dC_A}{dt} = -kC_A$ (18)

The initial condition is at $t = 0$, $C_A = 1 \text{ mol/m}^3$. The rate constant of reaction is 1 s^{-1} . Using the Runge-kutta fourth order method determine the concentration of A at 2s.

- (b) Derive the explicit Euler method using interpolation formula. (17)

2. (a) Derive the general solution of Riccati equation. (12)

- (b) Derive the general solution of an extraction process using analytical method. (12)

- (c) Find the particular solution of the equation below: (11)

$$y_{n+1} - 2y_n - 3y_{n-1} = (n+1)$$

3. (a) (20)

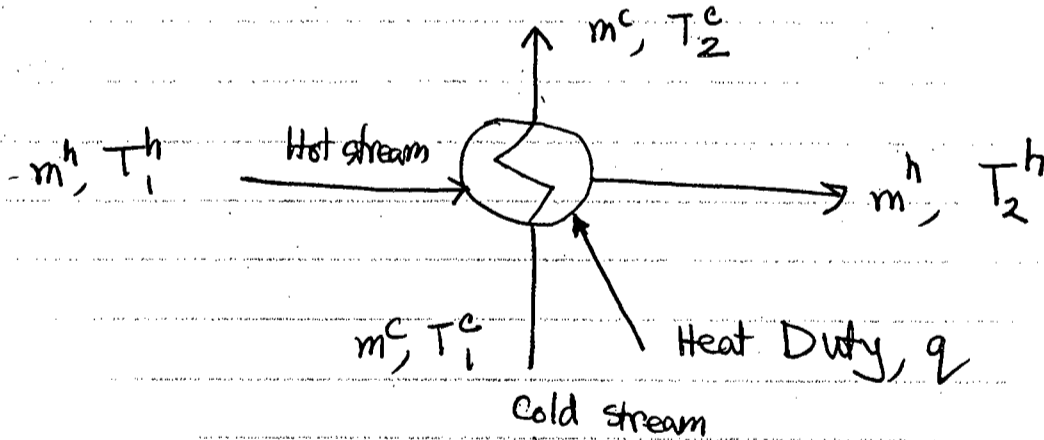

Fig: Counter Current Heat Exchanger

The heat exchanger can be modeled by:

Hot stream Energy balance: $m^h c_p^h (T_2^h - T_1^h) = q$

Cold stream Energy balance: $m^c c_p^c (T_2^c - T_1^c) = q$

$$C_p^h = a1 + b1 * T_h + C1 * (T_h)^2$$

$$C_p^c = a2 + b2 * T_c + C2 * (T_c)^2$$

where $T_h = (T_2^h + T_1^h)/2$ and $T_c = (T_2^c + T_1^c)/2$

= 2 =

CHE 455/CHE

Contd... Q. No. 3(a)

Given: $m^h = 100 \text{ kg/hr}$ $m^c = 110 \text{ kg/hr}$ $q = 35000 \text{ kJ/hr}$, $T_1^h = 350 \text{ K}$ $T_1^c = 300 \text{ K}$

$$\begin{aligned} a_1 &= 5.05 & b_1 &= 1.7 \text{E} - 2 & c_1 &= 6.0 \text{E} - 6 \\ a_2 &= 7.70 & b_2 &= 4.6 \text{E} - 4 & c_2 &= 2.5 \text{E} - 6 \end{aligned}$$

Convert the equations into a single variable form. Convert the model equations in function form. Convert the set of nonlinear equation to a set of linear equations ($\underline{J} \cdot \underline{\delta} = -\underline{f}$). Write the \underline{J} of system.

(b) Compare the merits and demerits of White box model & Black box model. (8)

(c) Describe the role of First principle model. (7)

4. (a) Solve the following linear algebraic equations using the Gauss - Seidel method (17)

$$\begin{aligned} 4x_1 + 2x_2 + x_3 &= 11 \\ -x_1 + 2x_2 &= 3 \\ 2x_1 + x_2 + 4x_3 &= 16 \end{aligned}$$

Note that for Gauss - Seidel to converge the equations are expressed in the form:

$$\begin{aligned} x_1^{n+1} &= \frac{11 - 2x_2^n - x_3^n}{4} \\ x_2^{n+1} &= \frac{3 + x_1^{n+1}}{2} \\ x_3^{n+1} &= \frac{16 - 2x_1^{n+1} - x_2^{n+1}}{4} \end{aligned}$$

(b) A liquid-liquid extraction process conducted in the Electrochemical Materials Laboratory involved the extraction of nickel from the aqueous phase into an organic phase. A typical set of experimental data: (18)

Ni aqueous phase, $a(g/l)$	2	2.5	3
Ni organic phase, $g(g/l)$	8.57	10	12

Assume, g is the amount of Ni in organic phase

a is the amount of Ni in aqueous phase

$$g = x_1 a^2 + x_2 a + x_3, \quad 2 \leq a \leq 3$$

The solution for the unknowns x_1, x_2, x_3 is given by

$$\begin{bmatrix} 4 & 2 & 1 \\ 6.25 & 2.5 & 1 \\ 9 & 3 & 1 \end{bmatrix} \begin{bmatrix} x_1 \\ x_2 \\ x_3 \end{bmatrix} = \begin{bmatrix} 8.57 \\ 10 \\ 12 \end{bmatrix}$$

Find the values of x_1, x_2, x_3 using Gauss Elimination method.

CHE 455/CHE

SECTION – B

There are **FOUR** questions in this section. Answer any **THREE**.

5. (a) Write down the steps used to solve optimization problems. Also show the hierarchy of levels of optimization. (6+4=10)

(b) Find the volume of the largest right circular cylinder that can be inscribed inside a sphere of radius R. (15)

(c) A trucking company has borrowed \$600,000 for new equipment and is contemplating three kinds of trucks. Truck A costs \$10,000, truck B \$20,000 and truck C \$23,000. How many trucks of each kind should be ordered to obtain the greatest capacity in ton-miles per day based on the following data? (10)

Truck A requires one driver per day and produces 2100 ton-miles per day.

Truck B requires two drivers per day and produces 3600 ton-miles per day.

Truck C requires two drivers per day and produces 3786 ton-miles per day.

There is a limit of 30 trucks and 145 drivers.

Formulate a *complete* mathematical statement of the problem, and label each individual part, identifying the objective function and constraints with the correct units (\$, days, etc.). Make a list of the variables by names and symbol plus units.

6. (a) Write the general form of a NLP problem statement and mention the usual meaning of the symbols you used. State the conditions when it becomes unconstrained, bound-constrained and linearly constrained. (9)

(b) How will you define continuity of a function? Also write a short note on Hessian matrix. (6)

(c) Determine the convexity or concavity of the following objective functions: (any two) (12)

(i) $f(x_1, x_2) = (x_1 - x_2)^2 + x_2^2$

(ii) $f(x_1, x_2, x_3) = x_1^2 + x_2^2 + x_3^2$

(iii) $f(x_1, x_2) = e^{x_1} + e^{x_2}$

(d) The total annual cost of operating a pump and motor C in a particular piece of equipment is a function of x, the size (horsepower) of the motor, namely (8)

$$C = \$500 + \$0.9x + \frac{\$0.03}{x}(150,000)$$

Find the motor size that minimizes the total annual cost.

CHE 455/CHE

7. (a) You are given the following LP equation sets: (12)

$$\begin{aligned} x_1 - 2x_2 + x_3 &= 7 \\ x_1 - 3x_2 + x_4 &= 4 \\ x_1 + 3x_2 + f &= 0 \end{aligned}$$

Is the problem that leads to the preceding formulation solvable? How do you interpret this problem geometrically?

(b) Apply simplex rule to minimize f for the following LP equation sets. (23)

$$\begin{aligned} 4x_1 + 2x_2 + x_3 &= 6 \\ 6x_1 + 3x_2 + x_4 &= 9 \\ x_1 + 3x_2 + f &= 0 \end{aligned}$$

8. (a) Write some name of the methods that can be used to solve nonlinear programming problems. What will you do if NLP Algorithm does not work? (10)

(b) Prepare a graph of the following constraints and objective function, and solve the following linear programming problem. (15)

Minimize: $f = x_1 + x_2$

Subject to:

$$\begin{aligned} x_1 + 3x_2 &\leq 12 \\ x_1 - x_2 &\leq 1 \\ 2x_1 - x_2 &\leq 4 \\ 2x_1 + x_2 &\leq 8 \\ x_1 \geq 0 \quad x_2 &\geq 0 \end{aligned}$$

(c) Feed to three units is split into three streams: F_A , F_B and F_C . Two products are produced: P_1 and P_2 (see the following figure), and the yield in weight percent by unit is (10)

Yield (wt%)	Unit A	Unit B	Unit C
P_1	40	30	50
P_2	60	70	50

Each stream has values in \$/lb as follows:

Stream	F	P_1	P_2
Values	0.4	0.6	0.3

Because of capacity limitations, certain constraints exists in the stream flows:

- (i) The total input feed must not exceed 10,000 lb/day
- (ii) The feed to each of the units A, B and C must not exceed 5000 lb/day
- (iii) No more than 4000 lb/day of P_1 can be used, and not more than \$7000 lb/day of P_2 can be used.

CHE 455/CHE

Contd... Q. No. 8(c)

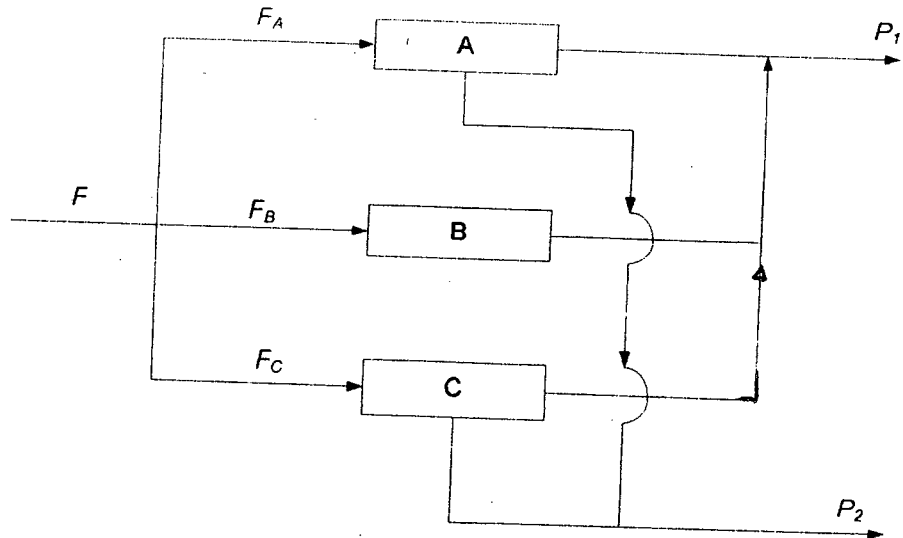

In order to determine the values of F_A , F_B and F_C that maximize the daily profit, prepare a mathematical statement of this problem as a linear programming problem.

BANGLADESH UNIVERSITY OF ENGINEERING AND TECHNOLOGY, DHAKA

L-4/T-1 B. Sc. Engineering Examinations 2012-2013

Sub : **CHE 405** (Plant Design I)

Full Marks : 210

Time : 3 Hours

The figures in the margin indicate full marks.

USE SEPARATE SCRIPTS FOR EACH SECTION

SECTION - AThere are **FOUR** questions in this Section. Answer any **THREE**.

1. (a) The purchased-equipment cost for a plant which produces Butanol is \$ 220 million. The following information is supplied – (20)
- The plant is highly instrumented
 - Requires a low level of service facilities
 - Because of several uncertainties a high contingency is recommended.
- Since the plant is an addition to an existing chemical complex, many facilities are common and built on the same compound. Using the supplied Table estimate the Total Capital Investment. What is the ratio of Direct and Indirect Costs?
- (b) Estimate by the turnover ratio method the fixed-capital investment required in 2000 for a proposed phosphoric acid plant (battery-limit) which has an annual capacity of 0.5 million tones of 100% phosphoric acid, using the data supplied in Table where the selling price of the acid is \$ 120 per metric ton. The plant will operate for 330 days/year. Repeat the calculation, using the cost capacity exponent method with data from the same Table. Using the cost indexes Table supplied update the calculated values to the year 2010. (5+5+2.5+2.5)
2. (a) Write a note on “Noxious Gas Removal” showing ten typical gaseous pollutants and their sources. (15)
- (b) List 6 (six) factors of Plant Location. Discuss 2(two) of these factors. (10)
- (c) List the factors that need to be considered in selecting materials-handling equipment. (5)
- (d) Why PATENTS need to be considered in designing a chemical plant. (5)
3. (a) A condenser for a distillation unit must be designed to condense 2300 kg of vapor per hour. The effective condensation temperature for the vapor is 78°C. The heat of condensation for the vapor is 420 kJ/kg. The cost of the cooling water at 21°C is \$ 2.66 per 100 m³. The overall heat-transfer coefficient at the optimum condition may be taken as 0.284 kJ/(m²-s-K). The cost for the installed heat exchanger is \$ 375 per square meter of heat transfer area, and annual fixed charges including maintenance are 22 percent of the initial investment. The heat capacity of the water may be assumed to be constant at 4.2 kJ(kg-K). If the condenser is to operate 5800 h/year, determine the cooling water flow rate in kg per hour for optimum economic conditions. DEVELOP THE FORMULA USED. (25)
- (b) Briefly explain the “Pinch” Technology Analysis. (10)

Contd P/2

CHE 405

4. (a) "Improvement of personal safety does not mean automatic improvement in process safety" – do you agree with this statement? Elaborate your answer with examples. (35)
- (b) Figure for Question No. 4(b) shows storage tank blanketed with nitrogen. This configuration resulted in an explosion and fire because of loss of inert material. Perform a HAZOP study on the tank to find out the possible causes of the incident and recommend possible modifications to improve the safety of the tank.

SECTION – B

There are **FOUR** questions in this Section. Answer any **THREE**.

5. (a) Write the general design consideration necessary for ferrous and non-ferrous metals and alloys. (10)
- (b) What should be your considerations while designing a piping system? (5)
- (c) Power requirement for the pump shown in Fig. for Q. No. 5(c) is to be found for the following operating conditions: (20)
- Fluid flow rate 108.5 m³/h
 - Fluid viscosity, $\mu = 10$ cp and S.G. = 1.35
 - ID of pipe = 9.75 inch
 - Length of pipe including fittings = 70 m
 - Fluid is to be delivered into the column maintained at 28 m.
 - Efficiency of pump 52%
- $f = 0.079 Re^{-0.25}$ Turbulent flow
- $f = \frac{16}{Re}$ Laminar flow
6. (a) Write general design features of different types of heat-exchangers. (9)
- (b) List the stresses that you would consider while designing a large and tall packed column during hydrostatic test. (5)
- (c) Explain the following with respect to mass transfer operations. (9)
- (i) HETP and NTU
 - (ii) Flooding and loading of a column
 - (iii) Maximum allowable vapor velocity
- (d) Explain the factors that influence plate and column efficiency. (6)

Contd P/3

CHE 405

7. (a) A shell and tube heat exchanger with one shell pass and one tube pass is being used as a cooler. The column medium is water on the shell side of the exchanger. Five segmental baffles with a 25% cut used on the shell side, and the baffles are spaced equally 2 ft apart. The safety factor for use in evaluating the shell side film coefficient is 1.6. The inside diameter of the shell is 23 inch. The OD of the tube 0.75 inch and the tubes are staggered ($a_0 = 0.33$). Clearance between the tubes is 0.25 inch. There is a total 384 tubes in the exchanger. Water flows through the shell side at a rate of 9000 lb/h. The average water temperature is 90°F and the average wall temperature on the water side is 100°F. Under this conditions, estimate the heat transfer coefficient for the water on the shell side of the exchanger. (29)

$$N_u = \frac{a_0}{F_s} R_e^{0.6} P_r^{1/3}$$

- (b) Discuss the factors to be considered while selection of heat exchanger types. (6)

8. A distillation column is separating a feed that is 50 mol% n-hexane and 50 mol% n-heptane. Feed is a saturated liquid. Average column pressure is 1 atm. Distillate composition is $x_D = 0.99$ (mol fraction of n-hexane) and $x_B = 0.001$. Feed rate is 1000 lb mole/hr internal reflux ratio $L/V = 0.8$. The column has a total reboiler and a total condenser. Determine the diameter and packing height of the column if random packing is used. Physical properties for pure n-hexane at 69°C are given below: (35)

Liquid sp.gr = 0.659

Surface tension, $G = 13.2$ dynes/cm

Saturated vapor density = 0.1917 lb/ft³

$$V_{nf} = 0.38 \left(\frac{\sigma}{20} \right)^{0.2} \left(\frac{\rho_L - \rho_v}{\rho_v} \right)^{0.5}$$

$$\text{HETP} = \begin{cases} D & \text{for } D \leq 0.5\text{m} \\ 0.5D^{0.3} & \text{for } D > 0.5\text{m} \\ D^{0.3} & \text{for absorption column with } D > 0.5\text{m} \end{cases}$$

Relative volatility = 2.5.

Chemical Engineering Plant Cost Index (averaged over year)

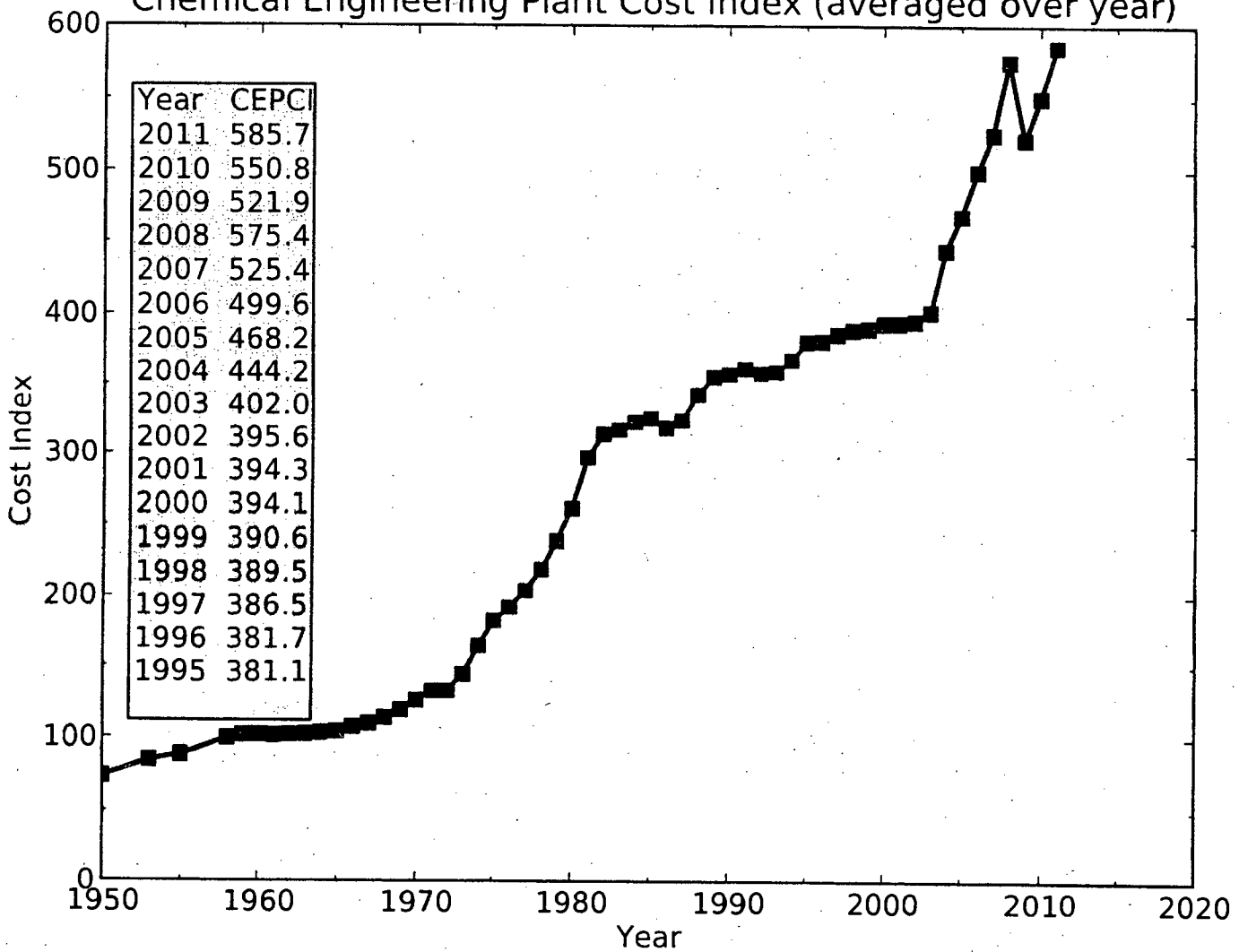

Estimation of capital investment cost (showing individual components)

Percentages indicated in the following summary of the various costs constituting the capital investment are approximations applicable to ordinary chemical processing plants. It should be realized that the values given vary depending on many factors, such as plant location, type of process, and complexity of instrumentation.

Direct costs = material and labor involved in actual installation of complete facility (65–85% of fixed-capital investment)

A. Equipment + installation + instrumentation + piping + electrical + insulation + painting (50–60% of fixed-capital investment)

1. Purchased equipment (15–40% of fixed-capital investment)
2. Installation, including insulation and painting (25–55% of purchased-equipment cost)
3. Instrumentation and controls, installed (8–50% of purchased-equipment cost)
4. Piping, installed (10–80% of purchased-equipment cost)
5. Electrical, installed (10–40% of purchased-equipment cost)

B. Buildings, process, and auxiliary (10–70% of purchased-equipment cost)

C. Service facilities and yard improvements (40–100% of purchased-equipment cost)

D. Land (1–2% of fixed-capital investment or 4–8% of purchased-equipment cost)

Indirect costs = expenses which are not directly involved with material and labor of actual installation of complete facility (15–35% of fixed-capital investment)

1. Engineering and supervision (5–30% of direct costs)
2. Legal expenses (1–3% of fixed-capital investment)
3. Construction expense and contractor's fee (10–20% of fixed-capital investment)
4. Contingency (5–15% of fixed-capital investment)

Fixed-capital investment = direct costs + indirect costs

Working capital (10–20% of total capital investment)

Total capital investment = fixed-capital investment + working capital

Fixed capital investment
Power factor, x
for specified process plant.

Product in process	Process	Typical plant size	Fixed investment, million \$	Power factor for specified process plant
		10^3 kg/yr (10^3 ton/yr)		
Acetic acid	CH ₃ OH and CO—catalytic	9×10^3 (10)	8	0.68
Acetone	Propylene-copper chloride catalyst	9×10^4 (100)	33	0.45
Ammonia	Steam reforming	9×10^4 (100)	29	0.53
Ammonium nitrate	Ammonia and nitric acid	9×10^4 (100)	6	0.65
Butanol	Propylene, CO, and H ₂ O—catalytic	4.5×10^4 (50)	48	0.40
Chlorine	Electrolysis of NaCl	4.5×10^4 (50)	33	0.45
Ethylene	Refinery gases	4.5×10^4 (50)	16	0.83
Ethylene oxide	Ethylene—catalytic	4.5×10^4 (50)	59	0.78
Formaldehyde (37%)	Methanol—catalytic	9×10^3 (10)	19	0.55
Glycol	Ethylene and chlorine	4.5×10^3 (5)	18	0.75
Hydrofluoric acid	Hydrogen fluoride and H ₂ O	9×10^3 (10)	10	0.68
Methanol	CO ₂ , natural gas, and steam	5.5×10^4 (60)	15	0.60
Nitric acid (high-strength)	Ammonia—catalytic	9×10^4 (100)	8	0.60
Phosphoric acid	Calcium phosphate and H ₂ SO ₄	4.5×10^3 (5)	4	0.60
Polyethylene (high-density)	Ethylene—catalytic	4.5×10^3 (5)	19	0.65
Propylene	Refinery gases	9×10^3 (10)	4	0.70
Sulfuric acid	Sulfur—contact catalytic	9×10^4 (100)	4	0.65
Urea	Ammonia and CO ₂	5.5×10^4 (60)	10	0.70
		10^3 m ³ /day (10^3 bbl/day)		
Alkylation (H ₂ SO ₄)	Catalytic	1.6 (10)	23	0.60
Coking (delayed)	Thermal	1.6 (10)	31	0.38
Coking (fluid)	Thermal	1.6 (10)	19	0.42
Cracking (fluid)	Catalytic	1.6 (10)	19	0.70
Cracking	Thermal	1.6 (10)	6	0.70
Distillation (atm.)	65% vaporized	16 (100)	38	0.90
Distillation (vac.)	65% vaporized	16 (100)	23	0.70
Hydrotreating	Catalytic desulfurization	1.6 (10)	3.5	0.65
Reforming	Catalytic	1.6 (10)	34	0.60
Polymerization	Catalytic	1.6 (10)	6	0.58

CAPITAL COST DATA (2002)

¹Adapted from K. M. Guthrie, *Chem. Eng.*, 77(13): 140 (1970); and K. M. Guthrie, *Process Plant Estimating, Evaluation, and Control*, Craftsman Book Company of America, Solana Beach, CA, 1974. See also J. E. Haselbarth, *Chem. Eng.*, 74(25): 214 (1967), and D. E. Draycr, *Petro. Chem. Eng.*, 42(5): 10 (1970).
²These power factors apply within roughly a 3-fold ratio extending either way from the plant size as given.

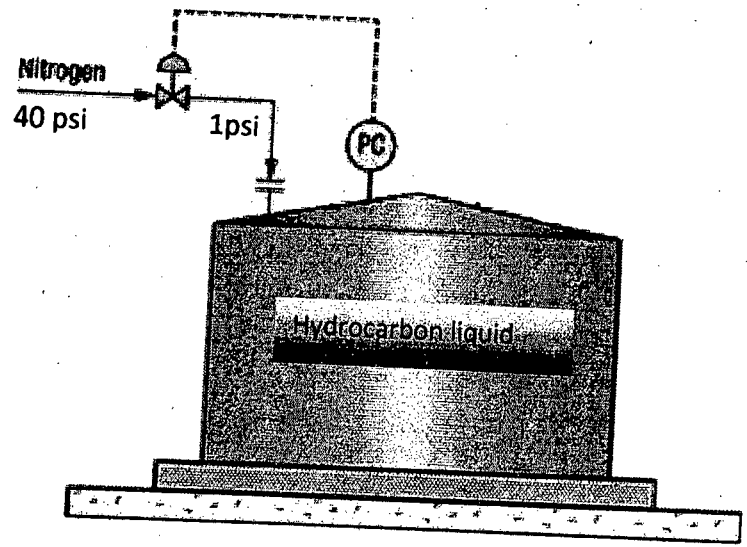
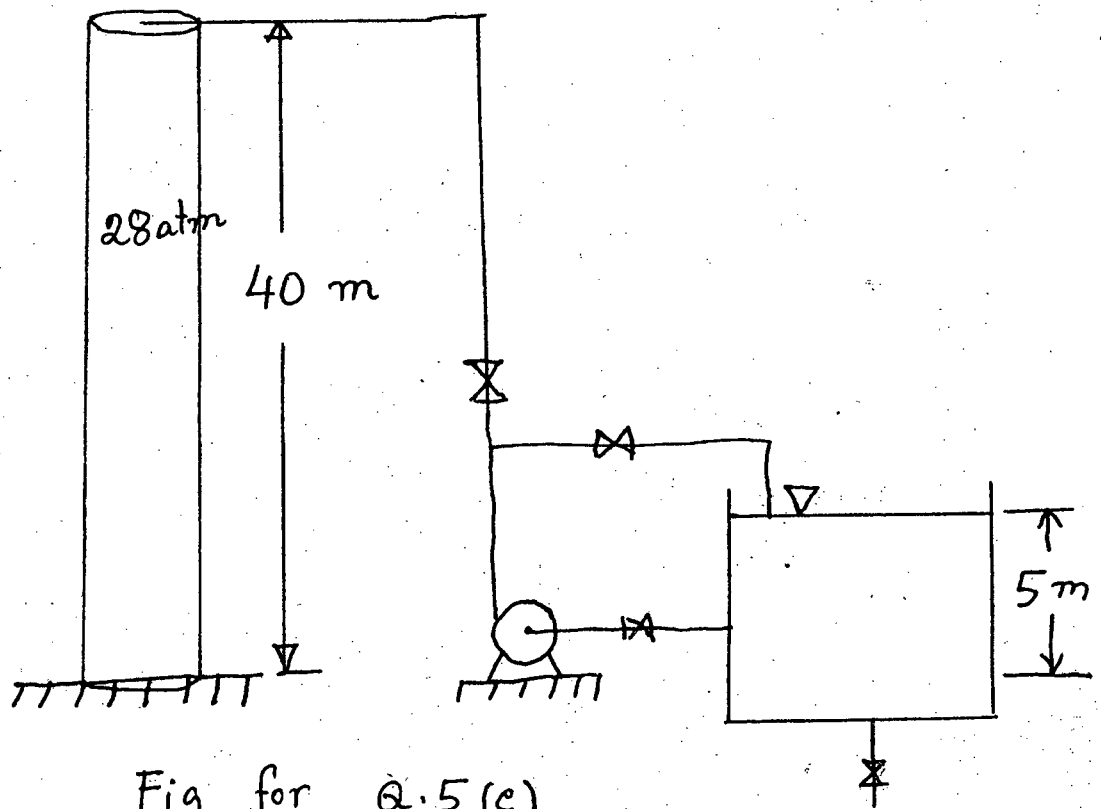

Figure for Question No. 4(b)



Density, viscosity, and thermal conductivity of water

Temperature, °F	Density of liquid water, lb/ft ³	Viscosity of water, centipoises	Thermal conductivity of water, Btu/(h)(ft ²)(°F/ft)
32	62.42	1.794	0.320
40	62.43	1.546	0.326
50	62.42	1.310	0.333
60	62.37	1.129	0.340
70	62.30	0.982	0.346
80	62.22	0.862	0.352
90	62.11	0.764	0.358
100	62.00	0.684	0.363
110	61.86	0.616	0.367
120	61.71	0.559	0.371
130	61.55	0.511	0.375
140	61.38	0.470	0.378
150	61.20	0.433	0.381
160	61.00	0.401	0.384
170	60.80	0.372	0.386
180	60.58	0.347	0.388
190	60.36	0.325	0.390
200	60.12	0.305	0.392
210	59.88	0.287	0.393
212	59.83	0.284	0.393

$$\mu_{CP} = 6.72 \times 10^{-4} \cdot 16 / (ft)(s)$$

$$V_{int} = C_{sb} \left(\frac{6}{20} \right)^{0.2} \left(\frac{\rho_L - \rho_V}{\rho_V} \right)^{0.5}$$

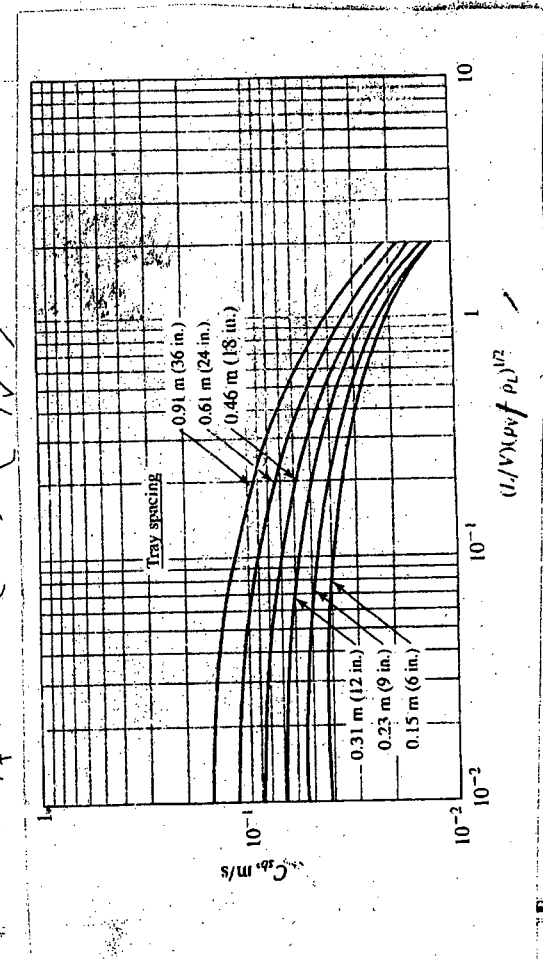

Fig for Q.7(a)

SECTION – A

There are **FOUR** questions in this section. Answer any **THREE**.

1. (a) With the help of a schematic, briefly describe the antibody production process by fermentation. (10)
 (b) What are the methods of quantify biomass growth? Draw the typical biomass growth curves observed in different methods. (6)
 (c) Write down the equation for oxygen transfer rate. Draw a concentration profile showing different steps of oxygen transport from a gas bubble to microorganism. List some factors that can affect the oxygen transfer rate. (2+6+5=13)
 (d) Define the following terms: Chemotaxis, Haptotaxis and Durotaxis. (6)

2. (a) Write short notes on the following bioreactor configurations with properly labelled schematics. (i) stirred tank reactor, (ii) packed-bed reactor. (6+6=12)
 (b) Starting from the mass balance, derive volumetric rate of biomass production in a CSTR. Show how you can calculate the optimum dilution rate for maximum production, D_{opt} in a CSTR. (8+3=11)
 (c) What is aseptic operation? What are the major sources of contamination in a bioprocess plant? Write down the value control sequence you should follow during aseptic inoculation in the system shown in Fig. 2(c). (2+2+8=12)

3. (a) Write down the equation for oxygen transfer rate. Draw a concentration profile showing different steps of oxygen transport from a gas bubble to microorganism. List some factors that can affect the oxygen transfer rate. (2+6+5=13)
 (b) A pharmaceutical company produces active component of an ointment by enzymatic reaction. Michaelis constant, K_m and maximum rate V_{max} are 8.9 mM and $2.5 \text{ mmol m}^{-3} \text{ s}^{-1}$, respectively. Initial substrate concentration in 12 mM. How much time is required for 60% substrate conversion in a batch reactor? Substrate molecular weight is 1667 g/mol. (6+6=12)
 If the same reaction is performed in a 5 m^3 continuous reactor, calculate the feed rate required to achieve 90% substrate conversion. The microorganism cultivated during the reaction has maximum growth rate, $\mu_m = 0.45 \text{ h}^{-1}$, half saturation constant, $K_S = 0.8 \text{ Kg m}^{-3}$ and yield $Y_{X/S} = 0.55 \text{ Kg Kg}^{-1}$.
 (c) Briefly discuss four different levels of a protein structure and mention the stabilizing interactions during each level. (10)

CHE 475

4. (a) What is downstream processing? Draw typical flow diagrams of downstream processing plant when the product is (i) inside the cell, (ii) outside of the cell. (2+3+3=8)
- (b) What is filter aid? What are the merits and demerits of filter aid? List at least six unit operations used during downstream processing and briefly discuss any two. (3+3+6=12)
- (c) An engineer is designing a biomaterial (density ρ , elasticity E , Poisson's ratio γ) and performed some protein (spherical with diameter D) binding experiment that made a complex of radius d at the binding site. Protein solution was flown at velocity V . It is known that dimensionless length d/D is a function of one or more dimensionless number. (10)
- $$d/D = f(V, \gamma, \rho, E)$$
- Do a dimensional analysis to predict the dimension less number(s). Elasticity has a dimension of $ML^{-1}T^{-2}$.
- (d) What is fluorescent microscopy? Draw a schematic showing the path of fluorescent light during microscopy. (1+4=5)

SECTION - B

There are **FOUR** questions in this section. Answer any **THREE**.

5. (a) What are the medical applications of the biomaterials? Write down the names and categories of the traditional and advanced biomaterials. (5+5)
- (b) As a biomaterial engineer what would be the various factors that you would consider for designing a new biomaterial? (9)
- (c) Briefly describe different means of biomaterial failure. (4)
- (d) What is polymerization? Write down the polymerization mechanism to produce Nylon 66 with proper chemical equation? What are the biomedical applications of Nylon? (3+5+4)
6. (a) Briefly discuss the important dimensionless numbers for microfluidic systems. (9)
- (b) What are isotropic and anisotropic etching techniques? Explain isotropic wet etching for 'Glass' based materials. (4+6)
- (c) What is surface tension? Write down the significance of surface tension in Biotechnology. (6)
- (d) Briefly describe the temperature effect and surfactant effect on surface tension. (5+5)
7. (a) What is Laplace Pressure? Using Laplace Pressure equation, describe capillary rise in a capillary tube. (4+6)
- (b) Briefly discuss the major categories of waste. (6)
- (c) What is compost? Describe different phases of the composting process. (3+6)
- (d) Discuss compost maturity and stability. Explain maturity assessment process of compost fertilizer using proper flow diagram. (4+6)

CHE 475

8. (a) Write short notes on (i) Okazaki fragments, (ii) Restriction Endonucleases, (iii) DIC microscopy. (3+3+3)
- (b) What is the difference between cloning vector and expression vector? Write down few properties of the expression vectors you should look for during protein production by recombinant DNA technologies. (2+3)
- (c) What are the basic sequential steps in signal transduction in a cell? Discuss the benefits of microscopy over traditional approaches during quantification of signal transduction. (3+6)
- (d) *Aspergillus niger* is grown in a 10 m^3 fermenter, where the aeration capacity is 0.34 s^{-1} and oxygen solubility is 8.0 g m^{-3} . If the specific rate of oxygen uptake is $25 \text{ mmol g}^{-1} \text{ h}^{-1}$, what is the maximum possible cell concentration? (6)
- (e) Design a set of 12-nucleotide long forward and reverse primers to amplify the following sequence in a PCR machine. Write down the primer sequence in proper convention. Underlined region represent the gene of interest to be amplified. (6)
- 5' CGT CCT TGT GCA ATG GCG TGC CTA TAT CAA CGC GCG GTG GAT
CGA TGG CCA AAT 3'

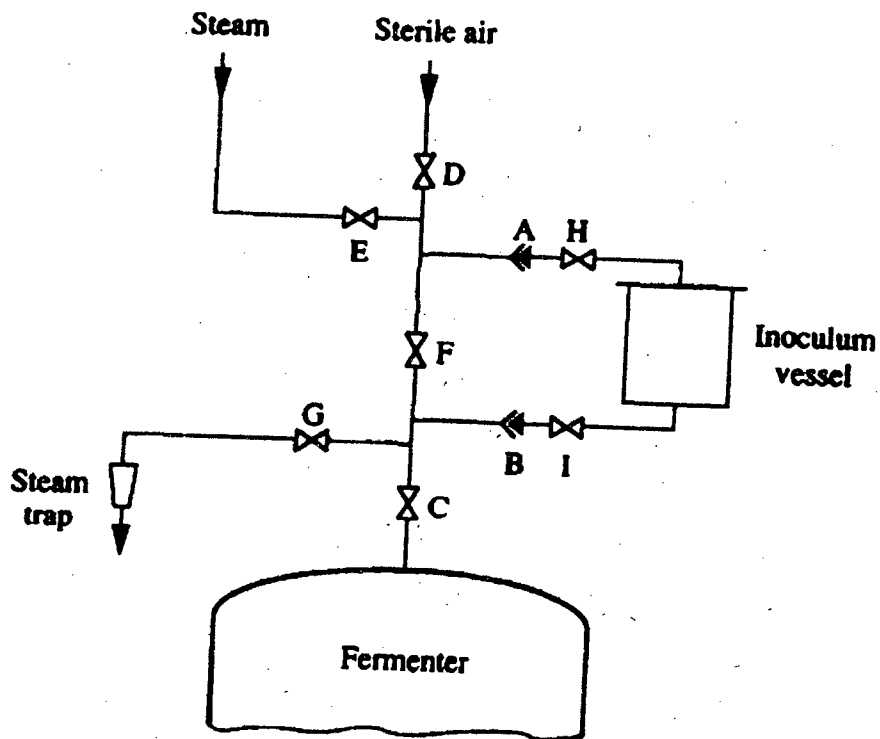

Figure for the problem 2(c)

SECTION – A

There are **FOUR** questions in this section. Answer any **THREE**.

1. (a) Discuss the theories of origin of petroleum. (15)
- (b) Give a detailed classification of petroleum. What are the major constituents of natural gas? (5+5=10)
- (c) Calculate the value of the formation volume factor of a dry gas with a specific gravity of 0.818 at reservoir temperature of 220°F and reservoir pressure of 2100 Psi. (5)
- (d) Starting from the definition of isothermal compressibility derive an expression of C_g for both ideal and non ideal gas. (5)

2. (a) Explain retrograde phenomena with the help of a P-T and a P-V diagram. What type of retrograde phenomena you can observe in a gas reservoir and why? (10+5=15)
- (b) With the help of a density-temperature diagram, explain the law of rectilinear diameter. What are the uses of density-temperature diagram? (5+5=10)
- (c) Explain Z-factor. Show the variations in the values of Z factor with pressure at different temperature and gas gravity. (10)

3. (a) Why is gas processing necessary? (5)
- (b) What are gas hydrates? Explain. Discuss the potential of gas hydrates as a source of energy. (5+5=10)
- (c) What is dew point depression? (5)
- (d) What is Joule Thomson effect? How can this method be used for natural gas liquid extraction? (5)
- (e) What are the uses of natural gas liquids? What is LNG. Explain. (5+5=10)

4. (a) What are the different types of gas well deliverability tests? Explain each of the tests with appropriate diagrams. (20)

CHE 491/CHE**Contd... Q. No. 4**

(b) The data in table below were reported for an isochronal test. Estimate AOF of the well and the stabilized deliverability equation. (15)

Test	Duration (hr)	P_{ws} or P_{wf} (Ps.)	q (mmscfd)
Initial shut in	48	1952	
First flow	12	1761	2.6
First shut in	15	1952	
Second flow	12	1694	3.3
Second shut in	17	1952	
Third flow	12	1510	5.0
Third shut in	18	1952	
Fourth flow	12	1320	6.3
Extended flow	72	1151	6.0
Final shut in	100	1952	

SECTION – B

There are **FOUR** questions in this section. Answer any **THREE**.

The symbols used in the equation represent their usual meaning.

5. (a) Develop an equation for the size of the smallest droplet that can be removed by the centrifugal action. (12)
- (b) What are the minimum functional requirement of a well designed separator? (6)
- (c) Design a vertical separator with a mist extractor that can handle 6.66 mmscfd of a 0.80 gravity gas at a GLR = 10.040 bbl/mscf. The oil gravity is 45° API, operating pressure is 400 psia, the operating temperature is 60°F, retention time is 3 min. (8)
- (d) Write a short note on "Low temperature separation". (9)
6. (a) Why must H₂S and CO₂ be removed from natural gas? Give at least three reasons for each separation. (6)
- (b) Compare the iron sponge and molecular sieve desulfurization processes. (13)
- (c) Write down the name of the sources of petroleum wastes. List the associated wastes that are found from the petroleum. (3+6=9)
- (d) Describe the environmental impact of petroleum wastes. (7)

CHE 491/CHE

7. (a) Write down the assumptions of steady state isothermal flow of gas through horizontal pipe. (6)
- (b) For a gas flow measuring device define "Accuracy" with example. (6)
- (c) Suppose a natural gas pipeline is L_A mile long with diameter D_A in. The length is paralleled with a new D_B inch internal diameter line of length L_B , where the two lengths are not equal. What would be the resulting increase in capacity? (10)
- (d) Write a short note on "Natural gas storage". (8)
- (e) For the figure shown below, calculate the percent change in flow rate. (5)

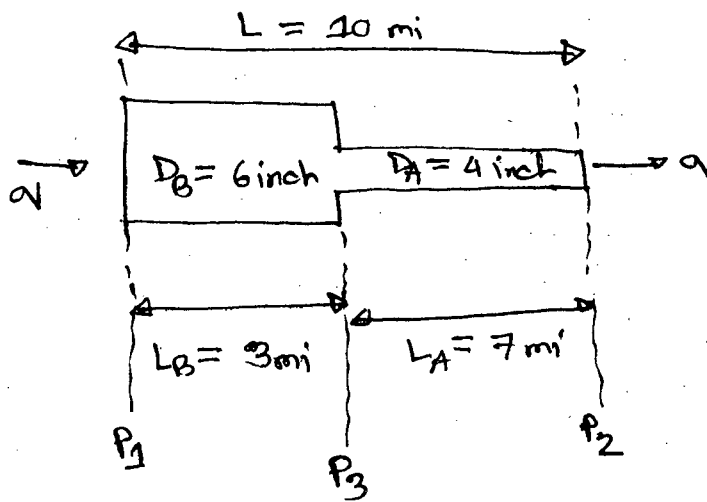

Weymouth evaluation for steady state isothermal flow of gas through a horizontal pipe is as follows—

$$q_h = 18.062 \frac{T_b}{P_b} \left[\frac{(P_1^2 - P_2^2) D^{16/3}}{r_g T L \bar{Z}} \right]^{0.5}$$

8. (a) Write down the names of the companies under "Petrobangla", indicating their role. (12)
- (b) Write down the names of the producing gas fields in Bangladesh along with their operating companies. (10)
- (c) What is meant by (8)
- (i) NGL
- (ii) LNG
- (iii) LPG
- (iv) CNG
- mention their uses.
- (c) Write down the name of the consumption sector of Natural gas in Bangladesh. (5)

CHE 491: Natural Gas Engineering

Symbols represent their usual meaning

Gas capacity (MMscfd) of a separator at standard condition

$$q_{sc} = \frac{2.40D^2 Kp (\rho_l - \rho_g)^{0.5}}{Z(T + 460) \rho_g^{0.5}}$$

K values for separators

Vertical separator, K = 0.167 with mist extractor

Horizontal Separator, K = 0.382 with mist extractor

Spherical Separator, K = 0.35 with mist extractor

Liquid Capacity $W = \frac{1440V_L}{t}$

$V_L = 0.1399D^2h$; For vertical separators

$V_L = 0.1399D^2(L/2)$; For horizontal single-tube separators

$V_L = 0.1399D^2L$; For horizontal double-tube separators

$V_L = 0.0466D^3(D/2)^{0.5}$; For spherical separators

$$\text{API gravity} = \frac{141.5}{\text{specific gravity @ } 60^\circ\text{F}} - 131.5$$

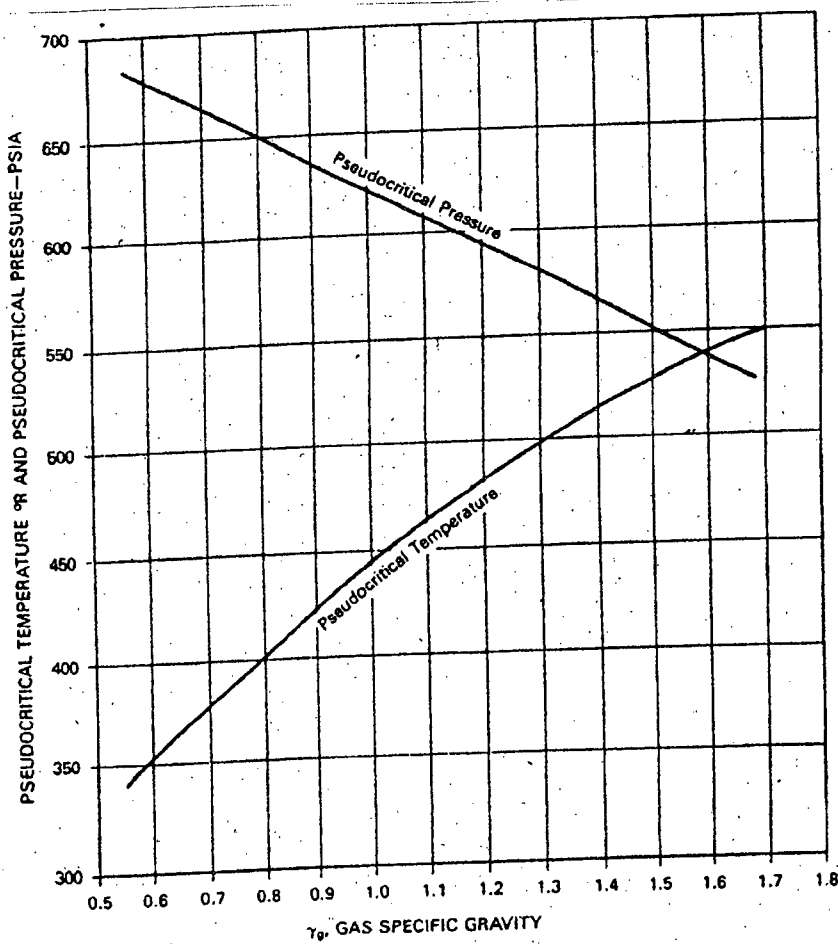

Pseudocritical properties of natural gases. (After Sutton.³²)

Fig for ques no 2(c)

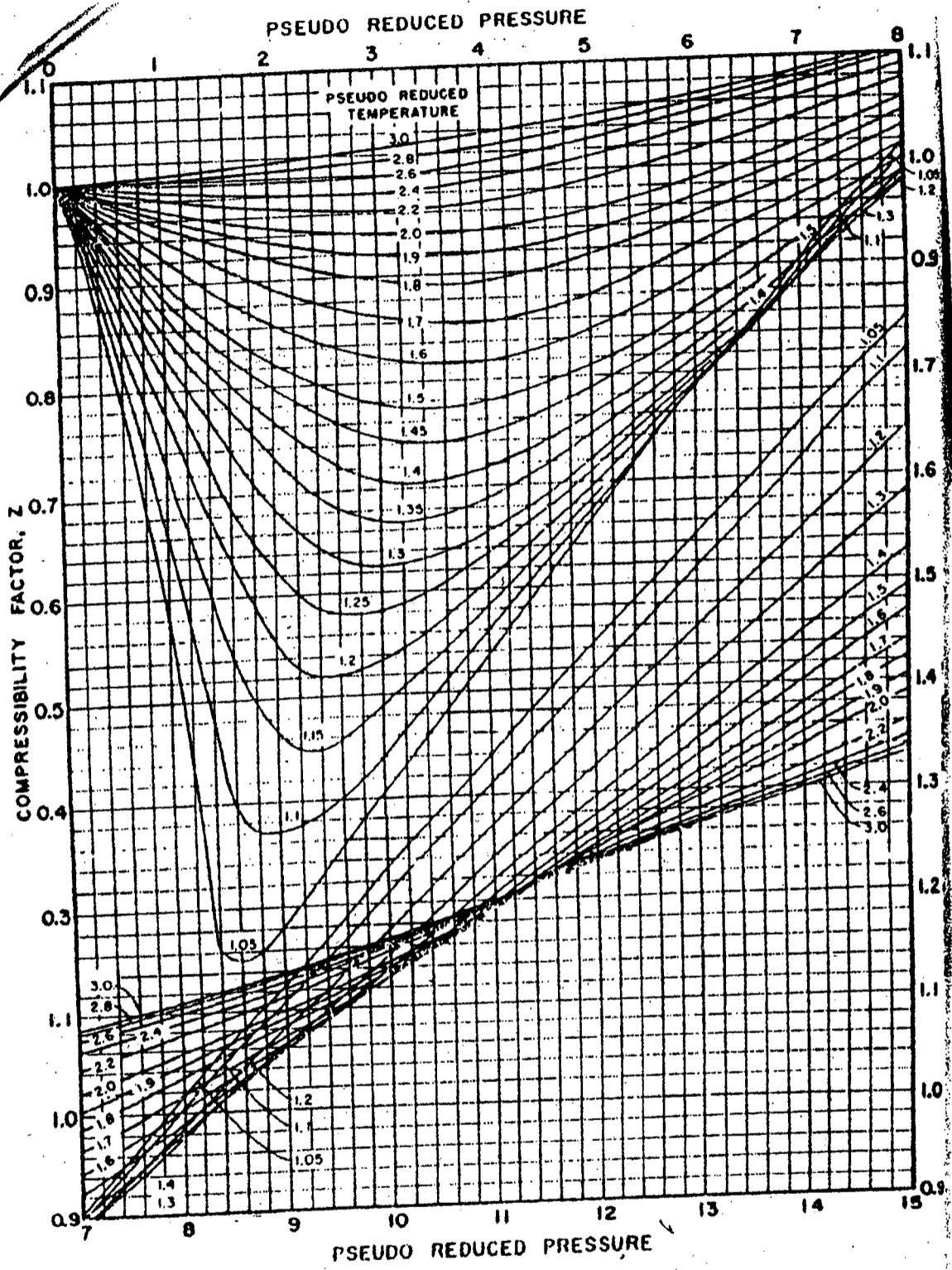

Compressibility factors for natural gases. (After Standing and Katz, *Trans.*)

Fig for ques no 1(c)