

(১২২৫২১৩) ১২
০৭-১০-১৩

L-1/T-1/WRE

Date : 07/10/2013

BANGLADESH UNIVERSITY OF ENGINEERING AND TECHNOLOGY, DHAKA

L-1/T-1 B. Sc. Engineering Examinations 2012-2013

Sub : **PHY 107** (Heat and Thermodynamics, Physical Optics, Waves and Oscillations)

Full Marks : 210

Time : 3 Hours

The figures in the margin indicate full marks.

USE SEPARATE SCRIPTS FOR EACH SECTION

SECTION - A

There are **FOUR** questions in this Section. Answer any **THREE**.

1. (a) What is a pyrometer? Describe the construction and working principle of the Fery's total radiation pyrometer. What is a rotating sector device? (27)
- (b) What are the advantages and disadvantages of Fery's total radiation pyrometer? (8)
2. (a) What are adiabatic, isothermal, isochoric and isobaric processes? (10)
- (b) Derive the expressions for the work done during expansion of an ideal gas in case of (i) isothermal process and (ii) adiabatic process. (20)
- (c) A gas is compressed adiabatically to $\frac{1}{5}$ th of its original volume. Find out the change in its temperature ($\gamma = 1.4$). (5)
3. (a) Discuss the main considerations behind the corrections of the ideal gas equation. (8)
- (b) Deduce and explain van der Waals' equation of state for a real gas. (20)
- (c) Obtain expressions for the critical pressure, critical temperature and critical volume in terms of the van der Waals' constants and universal gas constant. (7)
4. (a) Obtain an expression for the resultant displacement of a particle which is being simultaneously acted upon by two harmonic vibrations along an axis. What happens if the two vibrations are (i) in the same phase, (ii) in opposite phase and (iii) in opposite phase with their amplitudes being equal. (15)
- (b) What are Lissajous' figures? Derive a general expression for the formation of these Lissajous' figures when the time period of two simple harmonic vibrations are in the ratio of 1 : 1. (12)
- (c) Two simple harmonic oscillations acting simultaneously on a particle are given by $x_1 = 4 \sin \omega t$ and $x_2 = 3 \cos \omega t$ (in cgs unit). Calculate the resultant amplitude and the time period. Write down the equation of the resultant vibration. (8)

PHY 107

SECTION - B

There are **FOUR** questions in this Section. Answer any **THREE**.

5. (a) What is forced vibration? Establish the differential equation for the forced vibration in the presence of damping force. (2+6)
- (b) Solve the above equation and obtain an expression for its maximum amplitude. Explain the factors on which the sharpness of the resonance curve depends. (15+5)
- (c) A 2 kg object is executing damped oscillation where force constant $K = 400 \text{ N/m}$ and the damping coefficient $\rho = 1 \text{ sec}^{-1}$. It is driven by a periodic force of $F = 10 \cos 10t$ (in M.K.S unit). (7)
- (i) What is the amplitude of the oscillation?
- (ii) If the driving frequency is varied at what frequency will resonance occur?
- (iii) Find the amplitude at resonance.
6. (a) What are the characteristics of a mechanical wave? Obtain an expression for a plane progressive wave travelling in the + x direction. Hence derive the differential equation of one dimensional wave motion. (4+6+8)
- (b) What do you mean by phase velocity and group velocity? Establish a relationship between the two. Show that in a non-dispersive medium they are same. (12)
- (c) A simple harmonic wave is propagating through a medium. The displacement equation of the particle is $\Psi = 0.1 \sin \frac{2\pi}{0.10}(360t - x)$ in M.K.S unit. calculate its wave velocity and wavelength. (5)
7. (a) What are the Newton's rings? Describe an experiment to determine the radius of curvature of a plano-convex lens. (15)
- (b) What is resolving power? Derive an expression for resolving power of a telescope. (10)
- (c) The aperture of a telescope is 4.0 m. What is the least distance between the two objects at the moon's surface that can be just resolved by the telescope? What is the resolving power of that telescope? The distance between the earth and moon = $3.84 \times 10^8 \text{ m}$ and assume the mean wavelength of moon's light as 500 nm. (10)
8. (a) State and explain Brewster's law. Mention any two applications of it. (10)
- (b) What is double refraction? Give the Huygen's theory of double refraction in a uniaxial crystal. (18)
- (c) At a certain temperature the critical angle of incidence at the water-air interface for total internal reflection is $48^\circ 12''$ for a certain wave length. What are the polarizing angle and the angle of refraction for light incident on water at an angle that gives maximum polarization of the reflected light? (7)

1.10.2013

L-1/T-1/WRE

Date : 01/10/2013

BANGLADESH UNIVERSITY OF ENGINEERING AND TECHNOLOGY, DHAKA

L-1/T-1 B. Sc. Engineering Examinations 2012-2013

Sub : **HUM 111** (English)

Full Marks: 140

Time : 3 Hours

USE SEPARATE SCRIPTS FOR EACH SECTION

The figures in the margin indicate full marks.

SECTION – A

There are **FOUR** questions in this section.

Answer Q. No. 1 and any other **TWO** from the rest.

1. Read the following passage carefully and answer all the questions given below:

(30)

Over the past few decades, migration has become a central element in the livelihood strategy of more and more people around the world. Although current flows of people in search of a better life may be proportionately no larger than they were at certain times in the nineteenth century, they involve for greater diversity of cultural contact and very large absolute numbers of migrants. The potential for disruption of existing forms of social organization in the communities and regions of origin of migrants is sometimes great — particularly when most able — bodied members of households depart, leaving the young and the old to cope as best they can. Women, who remain behind when men migrate, must assume new roles and new tasks to those traditionally assigned to them. The potential for improving the standard of living of migrants' families is also considerable, as remittances are sent home and invested. Some migrants get ahead, and some find departure from their place of origin, a form of liberation from oppressive obligations. In all too many instances, however, migration remains a harsh necessity — a last resort involving privation and infrequently the danger of physical harm.

In major receiving countries, international migration creates enormous problems of social integration and cultural adaptation which are currently at the centre of policy debate. The juxtaposition of people who often share neither a common language nor a common religion, and who have very different customs, make unusual demands of human tolerance and understanding. The arrival of large number of foreigners also create unusual strains on social services and local economics.

Questions:

- (i) What is the impact of migration on migrant families?
- (ii) How is present trend of migration different from that of early 19th century?
- (iii) Do you think that migration is changing the states of women? How?
- (iv) Why is policy formulation becoming difficult for the receiving countries?
- (v) What are the effects of migration on a society?
- (vi) Give the meanings of the following words as used in the passage:
diversity, disruption, privation, adaptation, juxtaposition.

Contd P/2

HUM 111

2. (a) As an Assistant Engineer of a company you have recently bought some electrical appliances for your organization. Since the appliances are found to be sub-standard, write a letter of complain for the replacements of those products. (10)
- (b) Write the phonetic spelling of the following words: (Any five) (10)
father, about, reach, basic, paper, hungry.
3. (a) Write a dialogue between two students of WRE department about their future plane. (10)
- (b) Write a short essay on any one of the following topics: (10)
- (i) Women in Nation Building
 - (ii) Environmental disasters
 - (iii) Technology today
4. (a) Transform the following sentences as directed: (Any five) (10)
- (i) We are all born with a divine fire in us. (Complex)
 - (ii) Sujana kept her promises. (Compound)
 - (iii) Tom is popular, yet he cannot be called a great person. (Simple)
 - (iv) She is likely to arrive late. (Complex)
 - (v) Life is tough when you are an orphan. (Simple)
 - (vi) They went out leaving us. (Compound)
- (b) Write short notes on any two of the following: (10)
- (i) Consonant sounds
 - (ii) Front matter of a report
 - (iii) Components of a paragraph.

SECTION – B

There are **FOUR** questions in this section.

Question No. 5 is compulsory. Answer any **TWO** from the rest.

Symbols indicate their usual meaning.

5. (a) Explain with reference to the context any one of the following: (08)
- (i) "All these things, which another woman of her station would not have noticed, tortured and angered her."
 - (ii) "The state is not God. It has not the right to take away what it cannot restore when it wants to."
- (b) Answer any one of the following: (10)
- (i) Why did the Lawyer denounce all material pursuits at the end of the story "The Bet"?
 - (ii) How is the Diamond Necklace the representation of a social reality?

HUM 111

- (c) Answer any three of the following: (12)
- (i) How did Matilda and her husband suffer to repay the loan?
 - (ii) Why did Circe fall at Odysseus' knees and burst into tears?
 - (iii) How did Circe turn Eurylochus' men into pigs?
 - (iv) Give a brief description of the party arranged by the banker?
 - (v) What did the lawyer do in the last two years of his confinement?
6. Recast and correct any ten of the following sentences: (20)
- (i) Bangladesh is facing soring unemployment problem.
 - (ii) The house beside the pond is their's.
 - (iii) Laura is an alumnus of the Oxford.
 - (iv) I met him sometimes in last summer.
 - (v) Has is not as tall as his father.
 - (vi) I have other books beside this.
 - (vii) Young men dream glory and riches.
 - (viii) The music created an allusion that it was coming from the next room.
 - (ix) Rabindranath occupies a most unique place in literature.
 - (x) The story has no morale.
 - (xi) Fifteen minutes are allowed to each speaker.
 - (xii) The committee is divided in their opinions.
7. (a) Write down meaning of **any ten** of the following words: (10)
- Abhor, Brittle, Cataclysm, Deride, Equitably, Flip, Glib, Henceforth, Indictment, Limpid, Menace, Pact.
- (b) Make sentences with **any ten** of the following words: (10)
- Hilarious, Bicker, Brandish, Cluttered, Diffidence, Elusive, Flicker, Handy, Loot, Meddle, Outrageous, Remnant.
8. Write a precis of the following passage with a suitable title: (20)
- As what geographers have estimated, about twenty percent of the earth's surface is occupied by deserts. A majority of us view deserts as one unique kind of landscape — areas with little or no rainfalls. In actual fact, there are differences between the deserts, though in varying degrees. While it is common for laymen like us to see deserts as rocky or covered with gravel or pebbles, there are some where large sand dunes inhabit. Despite the fact that rainfall is minimal, temperatures do change in deserts, ranging from seasonal ones to daily changes where extreme hotness and coldness are experienced in the day and night.

HUM 111

Contd... Q. No. 8

Unfavorable conditions in the deserts, especially the lack of water, have discouraged many living things from inhabiting these landscapes. Nevertheless, there are exceptionally surviving ones which through their superb tactics, have managed to live through and are still going strong. One such kind is the specialist annual plants which overcome seasonal temperature changes with their extremely short, active life cycles. In events of sudden rain, the plant seeds pullulate and grow very quickly to make full use of the rain water. Their flowers bloom and set seeds that ripen quickly in the hot sun too. Once the water runs dry, the mother plant dies, leaving behind the drought-resistant seeds, waiting patiently for the next rainy season to arrive.

Samin
25.9.2013

L-1/T-1/WRE

Date : 25/09/2013

BANGLADESH UNIVERSITY OF ENGINEERING AND TECHNOLOGY, DHAKA

L-1/T-1 B. Sc. Engineering Examinations 2012-2013

Sub : **CHEM 115** (Chemistry I)

Full Marks : 210

Time : 3 Hours

The figures in the margin indicate full marks.

USE SEPARATE SCRIPTS FOR EACH SECTION

SECTION - A

There are **FOUR** questions in this section. Answer any **THREE**.

- (a) Derive an expression for the energy and radius of an electron in the n th orbit of H-atom. (7+7=14)

(b) Write a note on "physical significance of ψ and ψ^2 ." (6)

(c) Explain Heisenberg's uncertainty principle. Show that this principle is valid only for small particles and not for large particles. (5+10=15)
- (a) Calculate the frequency and wave number of yellow light having wave length of 580 nm. (5)

(b) Draw M.O. diagram and discuss stabilities, electronic configurations and characteristics of O_2^{2-} , O_2 and O_2^+ . (3×4=12)

(c) Which of the following molecules is planer and why? Discuss the shapes of all. (3×4=12)

BF_3 , NH_3 and PCl_5

(d) Explain why metallic character increases as we move down the group. (6)
- (a) Explain with examples Pearson's concept of hard and soft acids and bases. (15)

(b) What would you expect a solution of $FeCl_3$ to be and why? (5)

(c) Briefly describe the processes of wastewater treatment. (15)
- (a) Derive the expression for thermodynamic equilibrium constant. How will you determine the value of ΔH° from equilibrium constant measurement? (20)

(b) Explain the effect of pressure and addition of an inert gas on the equilibrium, (8)

$2 A (g) \leftrightarrow B (g) + 3 C (g)$

(c) Hydrogen sulfide, a colorless gas with a foul odor, dissociates on heating: (7)

$2 H_2S (g) \leftrightarrow 2 H_2 (g) + S_2 (g)$

when 0.100 mol H_2S was put into a 10.0 L vessel and heated to 1132 °C, it gave an equilibrium mixture containing 0.0285 mol H_2 . What is the value of K_c at this temperature?

Contd P/2

CHEM 115**SECTION – B**

There are **FOUR** questions in this section. Answer any **THREE**.

5. (a) Draw the flow sheet of wet process for manufacturing Portland cement. Discuss the chemical changes that occur in different sections of rotary kiln. **(6+8=14)**
- (b) What is retarder? Why is it essential ingredient of Portland cement? Give example of a retarder. **(3+3+1=7)**
- (c) What is the basic difference between Mortar and concrete? **(5)**
- (d) Write short notes on: (i) Sulphate resisting cement (ii) Pozzolana cement (iii) Air entrainment agents in cement. **(9)**
6. (a) What do you mean by colloid? How can you classify colloids according to the state (solid, liquid or gas) of the dispersed phase and of the continuous phase? Define with a suitable example from each category. **(2+8=10)**
- (b) Explain why the boiling point of a solution containing a nonvolatile solute is higher than the boiling point of a pure solvent. **(5)**
- (c) A 9.66 g sample of a compound with the empirical formula C_5H_4 is dissolved in 284 g of benzene. The freezing point of the solution is $1.37^\circ C$ below that of pure benzene. What are the molar mass and molecular formula of this compound? The value of the constant $K_f = 5.12^\circ C/m$. **(12)**
- (d) What is thermal pollution? Why is it harmful to aquatic life? **(5+3=8)**
7. (a) "Enthalpy is a State function". Explain. **(10)**
- (b) A quantity of 1.274 g of naphthalene ($C_{10}H_8$) was burned in a constant-volume bomb calorimeter. Consequently, the temperature of the water rose from $21.49^\circ C$ to $26.52^\circ C$. If the heat capacity of the bomb plus water was $10.17 kJ/^\circ C$, calculate the molar heat of combustion of naphthalene. **(10)**
- (c) Describe the chemical properties of water. Define heavy water and compare the physical properties of heavy water with ordinary water. **(10+5=15)**
8. (a) What is corrosion? Illustrate the mechanism of rusting. How corrosion can be prevented? **(2+8+3=13)**
- (b) Construct and describe the working principle of $H_2 - O_2$ fuel cell. Write the half-cell reactions and overall reaction of the cell: **(14+3=17)**
- $$Pt | H_2 (g) | H^+ (aq) || Br_2 (g) | Br^- (aq) | Pt$$
- (c) The voltaic cell: **(5)**
- $$Cd (s) | Cd^{2+} (aq) || Ni^{2+} (1.0 M) | Ni (s)$$
- has a cell potential of $0.240 V$ at $25^\circ C$. What is the concentration of cadmium ion?
-

Signature
20/07/13

L-1/T-1/WRE

Date : 27/07/2013

BANGLADESH UNIVERSITY OF ENGINEERING AND TECHNOLOGY, DHAKA

L-1/T-1 B. Sc. Engineering Examinations 2012-2013

Sub : **MATH 131** (Differential and Integral Calculus)

Full Marks : 210

Time : 3 Hours

The figures in the margin indicate full marks.

Symbols used have their usual meaning.

USE SEPARATE SCRIPTS FOR EACH SECTION

SECTION - A

There are **FOUR** questions in this section. Answer any **THREE**.

1. (a) Discuss the continuity and differentiability of the function (20)

$$f(x) = \begin{cases} x & \text{for } 0 < x < 1 \\ 2 - x & \text{for } 1 \leq x \leq 2 \\ x - \frac{1}{2}x^2 & \text{for } x > 2 \end{cases}$$

at $x = 1$ and $x = 2$. Draw the graph of $f(x)$.

- (b) Evaluate the following:

(i) $\lim_{x \rightarrow 0} \frac{\tan nx - n \tan x}{n \sin x - \sin nx}$ (8)

(ii) $\lim_{x \rightarrow 0} (\cot^2 x)^{\sin x}$ (7)

2. (a) If $y = a \cos(\log x) + b \sin(\log x)$, then prove that $x^2 y_{n+2} + (2n + 1)xy_{n+1} + (n^2 + 1)y_n = 0$. (10)

- (b) If $u = \cos^{-1} \frac{x + y}{\sqrt{x} + \sqrt{y}}$, show that $x \frac{\partial u}{\partial x} + y \frac{\partial u}{\partial y} + \frac{1}{2} \cot u = 0$. (10)

- (c) Show that $\frac{\partial^2 V}{\partial x^2} + \frac{\partial^2 V}{\partial y^2} = \frac{\partial^2 V}{\partial r^2} + \frac{1}{r} \frac{\partial V}{\partial r} + \frac{1}{r^2} \frac{\partial^2 V}{\partial \theta^2}$, where V is a function of x and y and $x = r \cos \theta$, $y = r \sin \theta$. (15)

3. (a) State Rolle's theorem and verify it for the function $f(x) = 2x^3 + x^2 - 4x - 2$. (12)

- (b) Expand $f(x) = e^x \sin x$ in powers of x in infinite series. (11)

- (c) If $x \cos \alpha + y \sin \alpha = p$ touches the curve $\frac{x^m}{a^m} + \frac{y^m}{b^m} = 1$, show that (12)

$$(a \cos \alpha)^{\frac{m}{m-1}} + (b \sin \alpha)^{\frac{m}{m-1}} = (p)^{\frac{m}{m-1}}$$

4. (a) Examine $f(x) = x^5 - 5x^4 + 5x^3 - 1$ for maximum or minimum values. (12)

- (b) Find the pedal equation of the parabola $y^2 = 4ax$. (11)

- (c) Find the radius of curvature at the point ' θ ' on the cycloid $x = a(\theta + \sin \theta)$, $y = a(1 - \cos \theta)$. (12)

MATH 131**SECTION - B**

There are **FOUR** questions in this section. Answer any **THREE**.

5. Integrate the following:

$$(a) \int \frac{x \tan^{-1} x}{(1+x^2)^{3/2}} dx \quad (10)$$

$$(b) \int (3x+2) \sqrt{2x^2+3x+4} dx \quad (12)$$

$$(c) \int \frac{x^3 + 4x^2 + 3x + 1}{\sqrt{x^2 + 3x + 4}} dx. \quad (13)$$

$$6. (a) \text{ Find a reduction formula for } I_n = \int (x^2 + a^2)^n dx \text{ and hence find } \int (x^2 + a^2)^3 dx. \quad (13)$$

$$(b) \text{ Evaluate: } \int_0^{\pi} \frac{x dx}{(a^2 \cos^2 x + b^2 \sin^2 x)^2}. \quad (12)$$

$$(c) \text{ Evaluate: } \lim_{n \rightarrow \infty} \left[\frac{n}{n^2} + \frac{n}{n^2+1^2} + \frac{n}{n^2+2^2} + \dots + \frac{n}{n^2+(n-1)^2} \right]. \quad (10)$$

$$7. (a) \text{ Evaluate: } \int_0^{\infty} \frac{x dx}{x^4 + 1}. \quad (11)$$

$$(b) \text{ Prove that } \Gamma\left(\frac{1}{2}\right) = \sqrt{\pi}. \quad (13)$$

$$(c) \text{ Evaluate: } \int_0^1 \int_0^{1-x} \int_0^{1-y^2} z dz dy dx. \quad (11)$$

$$8. (a) \text{ Prove that: } \int_0^1 x^m (1-x^n)^p dx = \frac{\Gamma(p+1)\Gamma\left(\frac{m+1}{n}\right)}{n\Gamma\left(p+1+\frac{m+1}{n}\right)}. \quad (12)$$

$$(b) \text{ If } y_1 = \frac{x_2 x_3}{x_1}, y_2 = \frac{x_3 x_1}{x_2}, y_3 = \frac{x_1 x_2}{x_3}, \text{ show that the Jacobian of } y_1, y_2, y_3 \text{ with respect to } x_1, x_2, x_3 \text{ is 4.} \quad (11)$$

$$(c) \text{ If } x^2 + y^2 + u^2 - v^2 = 0 \text{ and } uv + xy = 0, \text{ prove that } \frac{\partial(u, v)}{\partial(x, y)} = \frac{x^2 - y^2}{u^2 + v^2}. \quad (12)$$

Rafroz
11.09

L-1/T-1/WRE

Date : 10/07/2013

BANGLADESH UNIVERSITY OF ENGINEERING AND TECHNOLOGY, DHAKA

L-1/T-1 B. Sc. Engineering Examinations 2012-2013

Sub : **WRE 101** (Analytical Mechanics)

Full Marks : 280

Time : 3 Hours

The figures in the margin indicate full marks.

USE SEPARATE SCRIPTS FOR EACH SECTION

SECTION - A

There are **FOUR** questions in this Section. Answer any **THREE**.

1. (a) For the structure shown in figure-1, sketch the free body diagram for the members designated by the letter A, B and C. All plane surfaces and pins are smooth. Flexible weightless chords are represented by single lines. (10 $\frac{2}{3}$)
(b) A load 2000 lb acts on the boom CB as shown in the figure-2. Find the tension in the boom cable and the compression in the boom when the angle θ is 150° . (18)
(c) A frame structure is shown in the figure-3. Find the external support reactions at A and D and internal support reaction at B. Also determine the force in member CE. (18)

2. (a) In the truss as shown in figure-4, the wind loads of $F_1 = 1000$ lbs, $F_2 = 2000$ lbs and $F_3 = 1000$ lbs are assumed to act at the pin joints as shown. In order to allow for expansion, the support at G is on rollers. For $F_4 = 5000$ lbs, find the external reactions and the loads on members BC, BH and AH. (23 $\frac{2}{3}$)
(b) In figure-5, let $W_A = 400$ N, $f_A = 1/3$, and $f_B = 1/4$. If the body B is on the point of moving downward, determine the tension in the cable and the weight of body B. (23)

3. (a) The three hinged arch supports the loads as shown in figure 6. Determine (a) the external support reactions at A and C and internal reactions at B. (b) the loads on the members DB and EB. (15)
(b) What do you understand by a catenary? Derive the equation of sag for a catenary. (16 $\frac{2}{3}$)
(c) A bridge cable is suspended between two towers at the same elevation. The span is to be 1500 m, and the sag is 150 m, the allowable design load for the tension at the towers is 6000 tons. Determine the allowable horizontal uniform load per meter and the required length of cable. (15)

4. (a) Two spheres, each of weight 1000 N and of radius 25 cm rest in a horizontal channel of width 90 cm as shown in the figure-7. Find the reactions on the points of contact A, B and C. (15)
(b) A table whose top is triangular in shape as shown in the figure-8 has a load of $W = 100$ kg. What is the force on each leg at A, B and C? (15)

WRE 101

Contd ... Q. No. 4

(c) Three timbers AB, AC and AD, each 20 ft. long, from a tripod. The ends of the timber on the ground form an equilateral triangle BCD, the sides of which are each 20 ft. long. If the safe compressive load for each timber is 10,000 lb., what safe load W may be suspended from the point A.

(16 $\frac{2}{3}$)

SECTION - B

There are **FOUR** questions in this Section. Answer any **THREE**.

5. (a) Find the coordinate of the centroid of a area bounded by the curves $y^2 = 16x$ and $y = x$. (Figure 10).

(18)

(b) A body 'p' is projected vertically downward from a 500 ft cliff with an initial velocity of 10 fps. One second later, a body 'q' is projected vertically upward from the bottom of the cliff with an initial velocity of 70 fps. If time is to be measured from the beginning of the motion of 'p'. Determine

(16)

(i) when do these bodies pass one another?

(ii) how far above the bottom of the cliff are the bodies when they pass?

(iii) what is the direction of motion and speed of 'q' when they pass?

(c) A particle whose acceleration $a = 3t - 12$ fps^2 is moving at a certain instant in a straight line with an initial velocity of 15 fps in the same direction as the initial acceleration. At time $t = 3$ sec, what are the velocity and displacement of the particle?

(12 $\frac{2}{3}$)

6. (a) In figure 11, $W_A = 200$ lb, $W_B = 100$ lb, $f_A = 1/4$, $f_B = 1/3$.

(16)

(i) how far and in what direction does A travel from rest during 30 sec?

(ii) What is the tension in the cable C and cable D?

(b) For the 'T' section shown in Figure 12, determine maximum and minimum centroidal moments of inertia and minimum radius of gyration.

(20)

(c) Derive the expression for tangential and normal acceleration of a point moving in a curved path.

(10 $\frac{2}{3}$)

7. (a) A jet of stream flowing at the rate of $w = 15$ lb per sec, issues from a nozzle with velocity $v_{s1} = 400$ fps (Figure 13). It enters a fixed blade, and is turned through 120° before it is discharged.

(18 $\frac{2}{3}$)

(i) what are the horizontal (Q_x) and vertical (Q_y) components of the force exerted upon the fixed blade?

(ii) when the blade starts to move with a speed $v_b = 200$ fps toward the right, find the reactions Q_x and Q_y .

= 3 =

WRE 101**Contd ... Q. No. 7(a)**

(b) For the composite body as shown in Figure 14, find the radius of gyration about the geometric axis. Unit weight of the material of the composite body is 490 lb/ft^3 . **(10)**

(c) A 3 ft cylinder 'A' weighing 200 lb (Figure 15) has a central groove about which a weightless inextensible cord is wound. This cord passes over a smooth post 'C' then it goes vertically downward to another body 'B' weighing 32.2 lb. The cylinder has a moment of inertia of $6 \text{ ft}\cdot\text{lb}\cdot\text{s}^2$. If the friction force is sufficient to cause the cylinder to roll, then **(18)**

- (i) what is the tension in the cord?
- (ii) determine the speed of the center of gravity of 'A'.
- (iii) find the acceleration of 'B' after it has moved 20 ft downward.

8. (a) For the shaded area (Figure 16), compute **(16)**

- (i) I_x and I_y
- (ii) determine moment of inertia about a centroidal axis parallel to x axis.

(b) A weight 'M' is supported from a cable which is wound about a 4 ft drum (Figure 17). An 8 ft fly wheel turns with the drum. The total weight of the rotating part is 1288 lb and the radius of gyration is 2.5 ft. While 'M' travels 80 ft vertically downward, the speed of the rotating parts changes from 10 rpm to 120 rpm. The frictional force in the bearing acting tangentially to the 6 in shaft is 70 lb. What is the weight of 'M'? **(18)**

(c) Locate by integration the center of gravity of a slender wire bent into a parabolic curve whose equation is $y^2 = 4x$ and whose ends are defined by points (0, 0) and (4, 4). **(12 $\frac{2}{3}$)**

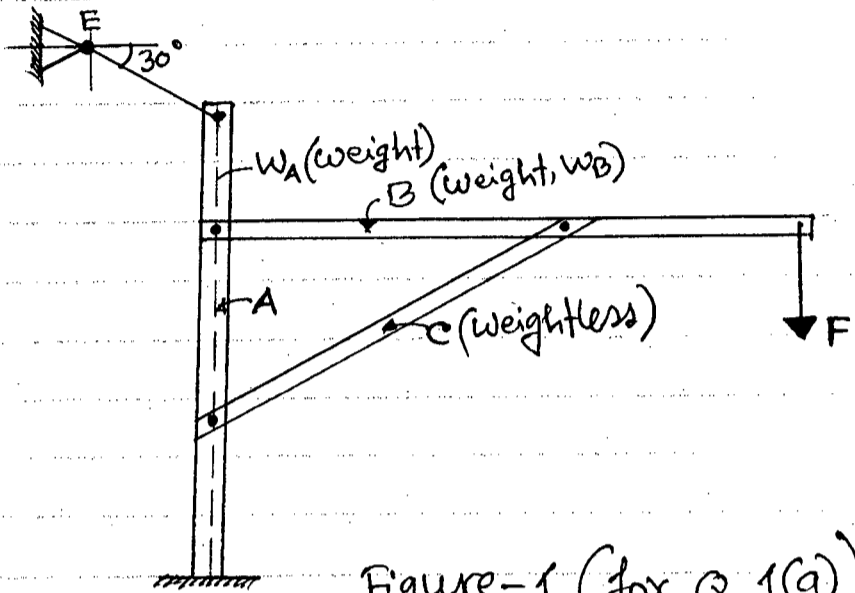

Figure-1 (for Q 1(a))

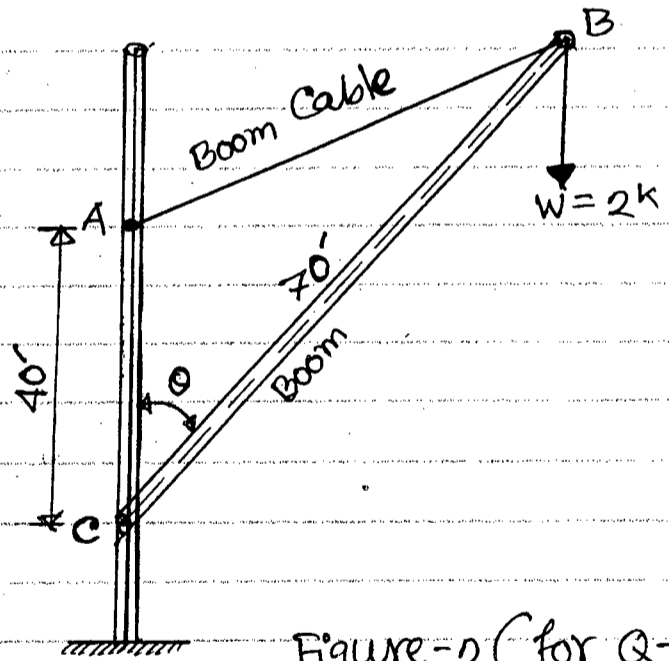

Figure-2 (for Q-1(b))

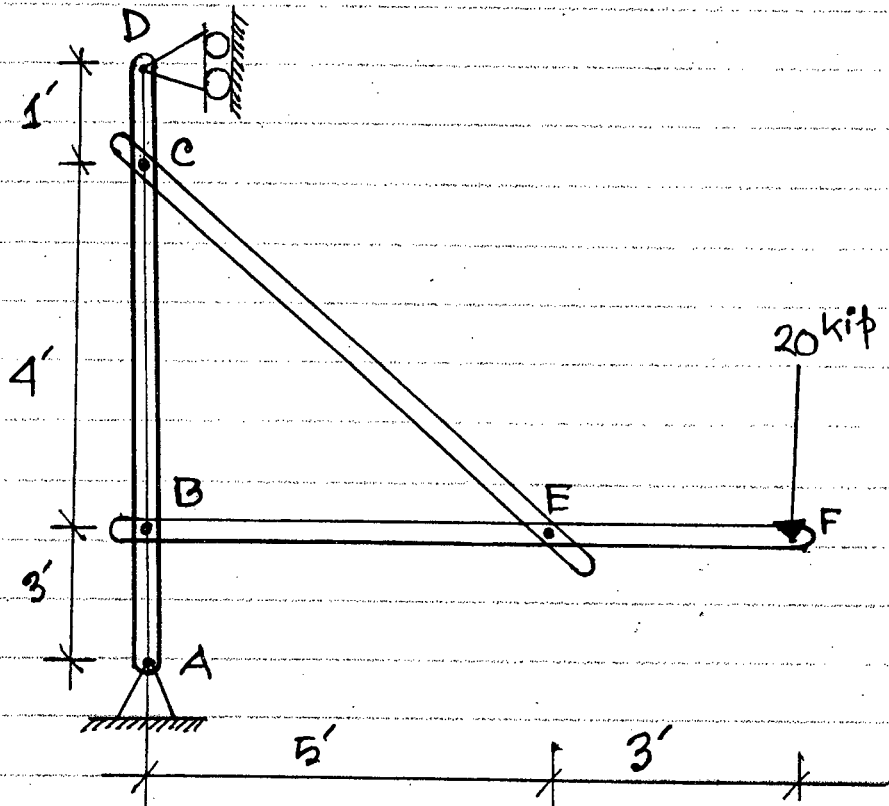

Figure-3 (for Q-1(c))

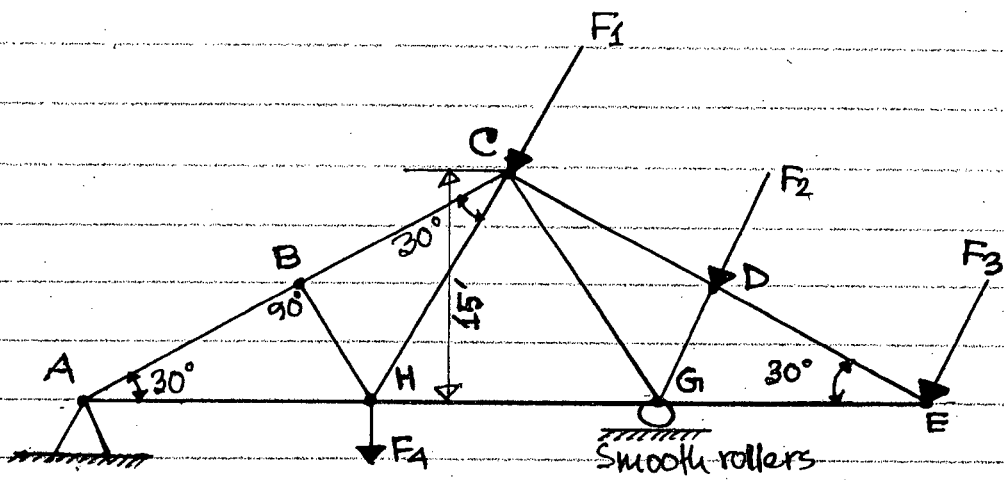

Figure-4 (for Q-2(a))

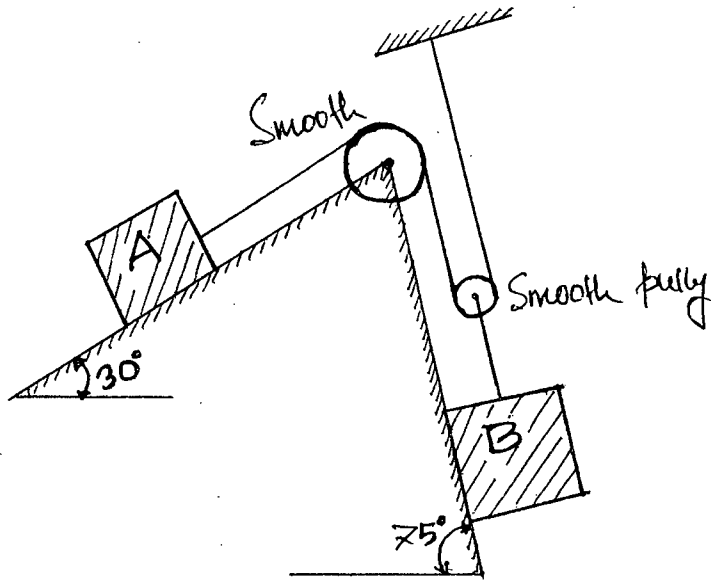

Figure-5 (for Q-2(b))

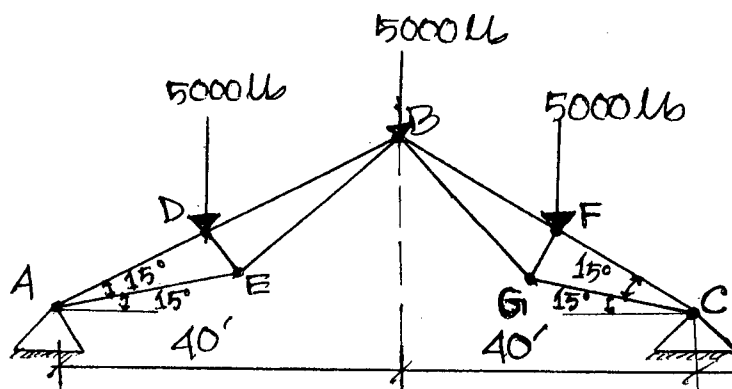

Figure-6 (for Q-3(a))

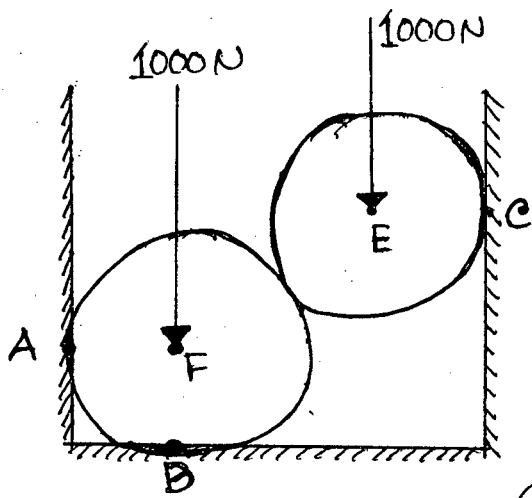

Figure-7 (for Q-4(a))

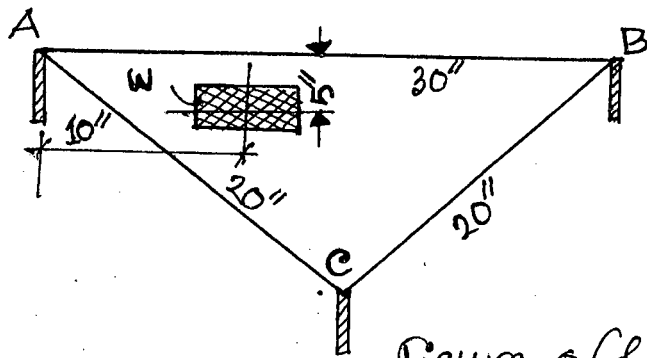

Figure-8 (for Q-4(b))

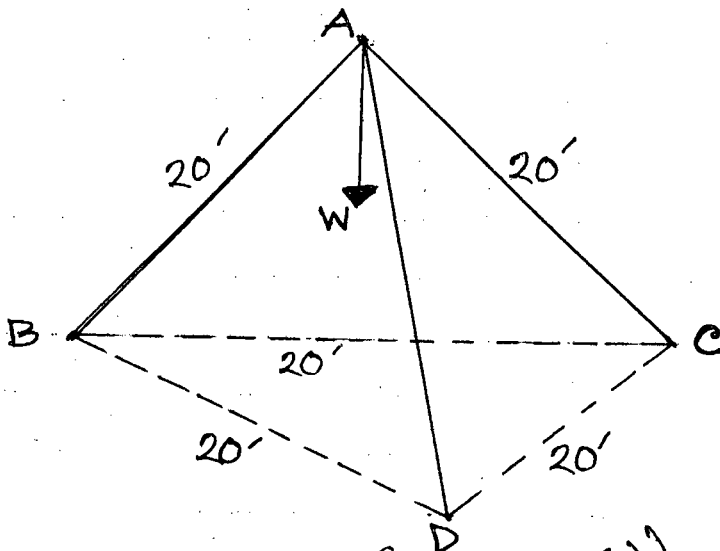

Figure-9 (for Q-4(c))

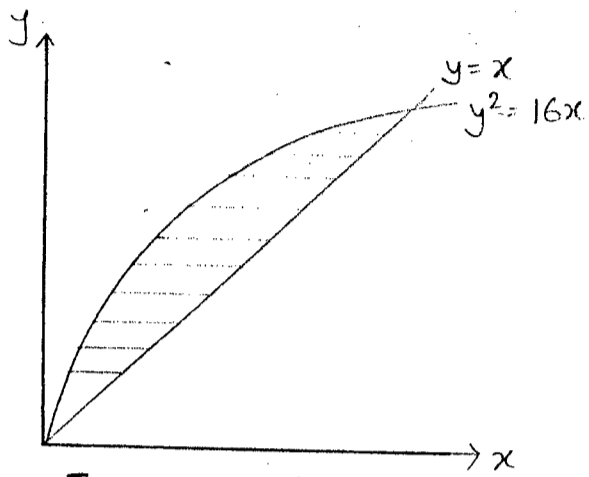

Figure 10 for Q.No. 5(a)

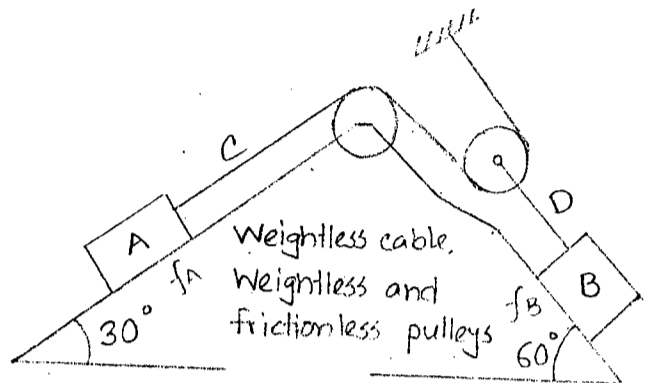

Figure 11 for Q.No. 6(a)

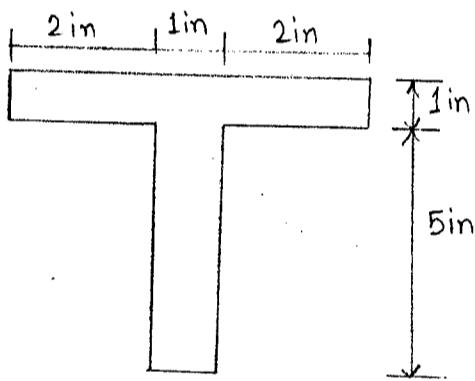

Figure 12 for Q.No. 6(b)

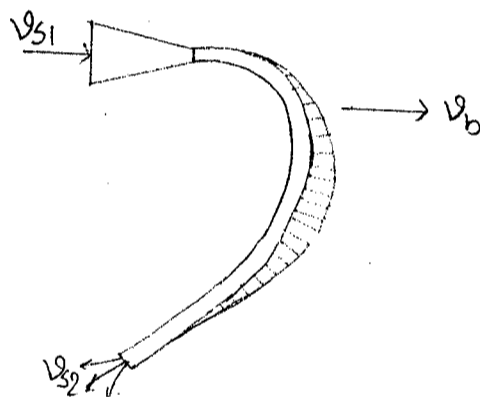

Figure 13 for Q.No. 7(a)

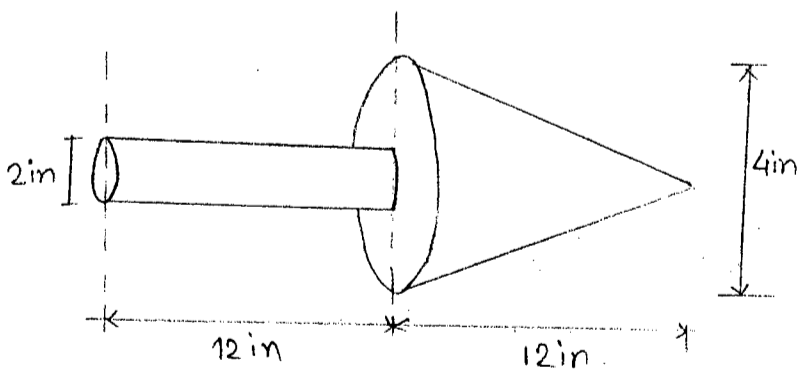

Figure 14 for Q.No. 7(b)

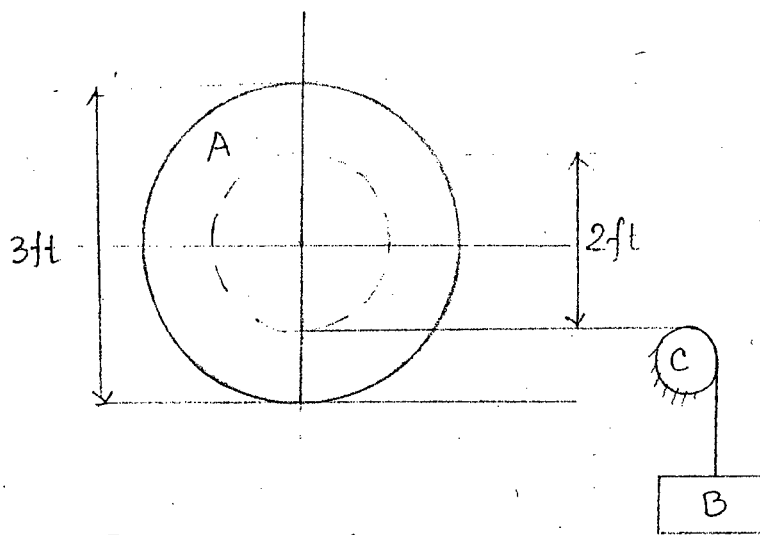

Figure 15 for Q.No. 7(c)

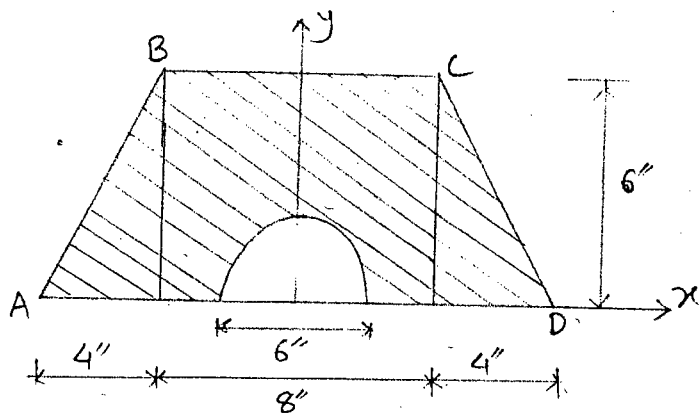

Figure 16 for Q.No. 8(a)

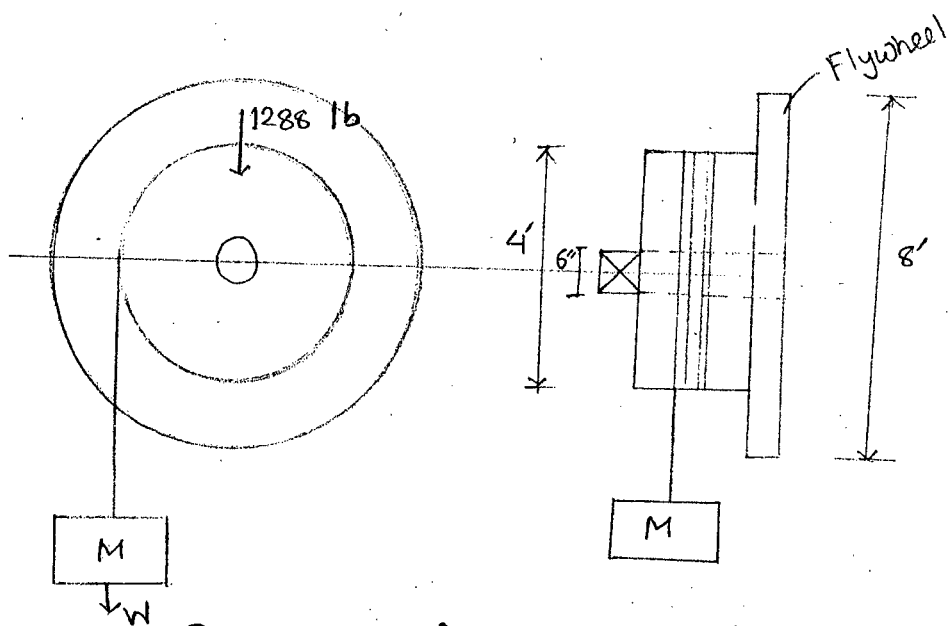

Figure 17 for Q.No. 8(b)