

L-1/T-1/MME

Date : 10/07/2013

BANGLADESH UNIVERSITY OF ENGINEERING AND TECHNOLOGY, DHAKA

L-1/T-1 B. Sc. Engineering Examinations 2012-2013

Sub : **MATH 171** (Calculus and Differential Equation)

Full Marks : 210

Time : 3 Hours

The figures in the margin indicate full marks.

USE SEPARATE SCRIPTS FOR EACH SECTION

SECTION - A

There are **FOUR** questions in this Section. Answer any **THREE**.

1. (a) A function $f(x)$ is defined as follows:

(20)

$$f(x) = \begin{cases} 1 & \text{when } x < 0 \\ 1 + \sin x & \text{when } 0 \leq x < \pi/2 \\ 2 + (x - \pi/2)^2 & \text{when } x \geq \pi/2 \end{cases}$$

Sketch the graph of the function. Also discuss the continuity and differentiability of the function at $x = \pi/2$.

- (b) If $\lim_{x \rightarrow 0} \frac{\sin 2x + a \sin x}{x^3}$ is finite, find the value of 'a' and the limiting value.

(15)

2. (a) If $y = A(x + \sqrt{x^2 + 1})^m + B(x + \sqrt{x^2 + 1})^{-m}$ then show that

(17)

$$(1 + x^2)y_{n+2} + (2n + 1)xy_{n+1} + (n^2 - m^2)y_n = 0.$$

- (b) Find the area of the triangle formed by the axes and the tangent line at $\theta = \pi/4$ of the curve $x = a \cos \theta, y = b \sin \theta$.

(18)

3. (a) Sum of the hypotenuse x and another side y of a right angled triangle is given, say k .

Find the angle between the two sides when the area of the triangle is maximum.

(23)

- (b) If $u = \sin^{-1} \frac{x}{y} + \tan^{-1} \frac{x}{y}$; then find the value of $x \frac{\partial u}{\partial x} + y \frac{\partial u}{\partial y}$.

(12)

4. Evaluate the following:

(i) $\int \frac{1}{\cos x + \sin x + 2} dx$

(12)

(ii) $\int \frac{\sqrt{9x+1}}{\sqrt{x-1}} dx$

(11)

(iii) $\int \frac{1}{(1-x)\sqrt{x^2+x+1}} dx$

(12)

Contd P/2

MATH 171(MME)**SECTION - B**There are **FOUR** questions in this Section. Answer any **THREE**.

5. Evaluate the following:

$$(a) \int_0^{\pi/4} \frac{dx}{\left(a^2 \cos^2 x + b^2 \sin^2 x\right)^2} \quad (12)$$

$$(b) \int_0^1 \frac{\ln(1+x)}{(1+x^2)} dx \quad (12)$$

$$(c) \int_0^{\pi} \frac{x \sin x}{1 + \cos^2 x} dx. \quad (11)$$

$$6. (a) \text{ Find the area of the region bounded by the curves } x^{2/3} + y^{2/3} = a^{2/3}. \quad (15)$$

$$(b) \text{ Find the volume of the solid generated by revolving the curve } y^2(a+x) = x^2(a-x) \text{ about the x-axis.} \quad (20)$$

7. Solve the following differential equations:

$$(a) (x^2y - 2xy^2)dx - (x^3 - 3x^2y)dy = 0 \quad (12)$$

$$(b) x^3 \frac{dy}{dx} - x^2y + y^4 \cos x = 0 \quad (12)$$

$$(c) y \ln y dx + (x - \ln y) dy = 0 \quad (11)$$

8. (a) According to Newton's law of cooling, the rate at which a substance cools in moving air is proportional to the difference between the temperature of the substance and that of the air. When a metal is removed from burner, its temperature is measured at 300°F. 5 minutes later, its temperature is 200°F. How long will it take to cool off to a room temperature 70°F. (11)

$$(b) \text{ Solve: } y'' + y = x \cos x - \cos x \text{ by the method of undetermined coefficients.} \quad (13)$$

$$(c) \text{ Solve: } x^4 \frac{d^4 y}{dx^4} + 6x^3 \frac{d^3 y}{dx^3} + 9x^2 \frac{d^2 y}{dx^2} + 3x \frac{dy}{dx} + y = 0. \quad (11)$$

L-1/T-1/MME

Date : 27/07/2013

BANGLADESH UNIVERSITY OF ENGINEERING AND TECHNOLOGY, DHAKA

L-1/T-1 B. Sc. Engineering Examinations 2012-2013

Sub : **MME 131** (Introduction to Metallurgy and Materials)

Full Marks : 210

Time : 3 Hours

The figures in the margin indicate full marks.

USE SEPARATE SCRIPTS FOR EACH SECTION

SECTION – A

There are **FOUR** questions in this Section. Answer any **THREE**.

1. (a) What information may be obtained from an equilibrium diagram? (10)
(b) Bismuth and antimony are completely soluble in both the liquid and solid states. Bismuth melts at 520°F and antimony melts at 1170°F. (25)
 - (i) Draw a hypothetical equilibrium diagram on a piece of graph paper and label all points, lines and areas.
 - (ii) For an alloy containing 40 percent antimony-
 - (a) Find the temperature of initial solidification.
 - (b) Find the temperature of final solidification
 - (c) Find the chemical composition and relative amounts of the phases present at 800°F.
2. (a) List the nondestructive tests that are generally applied to detect defects. With the aid of sketches discuss how magnetic particle inspection can be used to detect defects. (18)
(b) Explain the difference between through transmission and pulse-echo methods of ultrasonic inspection. What are the limitations of ultrasonic inspection? (17)
3. (a) Describe the sources of scrap metal. (15)
(b) Discuss the steps involved in hydrometallurgical processing. What are the advantages and disadvantages of hydrometallurgical processing? (20)
4. (a) Classify the fabrication techniques of metals. Describe, with neat sketches, the different types of forming operations. (20)
(b) 'The term Iron Age has low chronological value'- why? (5)
(c) How was Copper discovered by early man? (10)

SECTION – B

There are **FOUR** questions in this Section. Answer any **THREE**.

5. (a) What are semiconductors? Write down some of their distinguishing features and applications. (7)
(b) Explain the glass forming process with the help of diagrams. (13)
(c) What are the four conditions that must be satisfied to form a complete solid solution? (8)
(c) What are dislocations? (7)

Contd P/2

MME 131

6. (a) Calculate the atomic packing factor of a FCC and HCP crystal structure. (20)
- (b) Describe with the help of diagrams, a fabrication technique used for producing complex ceramic shapes. (15)
7. (a) What is ductile to brittle transition? Describe your answer with the help of a labelled diagram. (15)
- (b) With the help of a S-N curve explain what you understand by fatigue strength and fatigue life. Describe in detail, the three stages of fatigue failure. (20)
8. (a) What do you understand by creep? Explain the different stages in the creep strain (ϵ) Vs time curve with the help of a labelled diagram. (20)
- (b) Explain with the help of diagrams, how necking eventually leads to final shear fracture. (10)
- (c) Write a short note on strain hardening. (5)
-

01-10-13

L-1/T-1/MME

Date : 01/10/2013

BANGLADESH UNIVERSITY OF ENGINEERING AND TECHNOLOGY, DHAKA

L-1/T-1 B. Sc. Engineering Examinations 2012-2013

Sub : **CHEM 107** (Selected Topics on Inorganic and Physical Chemistry)

Full Marks : 210

Time : 3 Hours

The figures in the margin indicate full marks.

USE SEPARATE SCRIPTS FOR EACH SECTION

SECTION - A

There are **FOUR** questions in this section. Answer any **THREE**.

1. (a) What is half life of a reaction? Explain how the half life can be applied as a method for the determination of the order of a chemical reaction. (2+8=10)
(b) What are the main assumptions of transition state theory? Derive an expression of rate constant based on the assumptions. (15)
(c) The decomposition of N_2O_5 to NO_2 and O_2 is first order with a rate constant of $4.80 \times 10^{-4}/s$ at $45^\circ C$. (10)
 - (i) If the initial concentration is 1.65×10^{-2} mole/L, what is the concentration after 825 second?
 - (ii) How long would it take for the concentration of N_2O_5 to decrease to 1.00×10^{-2} mol/L from its initial value given in (i)?

2. (a) Derive the following expression of thermodynamic equilibrium constant (10)
$$\Delta F^\circ = - RT \ln K_a$$
where ΔF° is the change in standard free energy and K_a is the thermodynamic equilibrium constant.
(b) What is reaction quotient? How reaction quotient helps to predict the direction of a chemical reaction? (4+6=10)
(c) Derive the expression showing the quantitative effect of temperature on reaction equilibrium. (10)
(d) Show that in the decomposition of $CaCO_3$ by heating, the equilibrium constant is dependent only on the partial pressure of CO_2 gas. (5)

3. (a) What is a fuel cell? Explain the working principle of a H_2-O_2 fuel cell. (3+12=15)
(b) Define corrosion. What are the different methods can be applied to protect corrosion of metal? (2+10=12)
(c) Calculate the standard free energy change for the following reaction at $25^\circ C$ (8)
$$2 Au (s) + 3 Ca^{2+} (1.0 m) \rightarrow 2 Au^{3+} (1.0 m) + 3 Ca (s)$$
$$E^\circ Ca^{2+}/Ca = - 2.87 V$$
$$E^\circ Au^{3+}/Au = 1.50 V$$

Contd P/2

CHEM 107

4. (a) Group IA elements can form oxides (O_2^{4-}), peroxides (O_2^{2-}), and superoxides (O_2^-) with oxygen molecule. Predict the following properties of these oxides compared to oxygen molecule according to molecular orbital theory: (i) Electron configuration (ii) Bond order (iii) Magnetic properties and (iv) Relative stability. **(4×4=16)**
- (b) What is lattice energy? Calculate the lattice energy of an ionic compound according to Born-Haber cycle. **(7)**
- (c) NH_4^+ , H_3O^+ and NH_2^- all three ions have sp^3 hybridization but the bond angles are different from each other. Justify the statement. **(6)**
- (d) Draw the geometry of SF_4 and BrF_5 according to VSEPR model. **(6)**

SECTION - B

There are **FOUR** questions in this section. Answer any **THREE**.

5. (a) What are colligative properties? Write the equations relating each of these properties to the concentration of the solution. How ion pair influence on the colligative properties of an electrolyte solution? **(2+4+6=12)**
- (b) Camphor is a white solid that melts at $179.5^\circ C$. It has unusually large freezing-point depression constant ($40^\circ C/m$). The organic substance is dissolved in melted camphor, and the melting point of the solution is determined. (i) A 1.07 mg sample of a compound was dissolved in 78.1 mg of camphor. The solution melted at $176.0^\circ C$. What is the molecular mass of the compound? (ii) If the empirical formula of the compound is CH , what is the molecular formula? **(10)**
- (c) Define micelle. Explain how soap removes oil from a fabric. **(2+6=8)**
- (d) What do you mean by Van't Hoff factor? What information does this quantity provide? **(5)**
6. (a) State Hess's Law of heat summation. Apply Hess's Law in a suitable example to obtain the enthalpy for one reaction from the enthalpy changes of a number of other reactions. **(4+8=12)**
- (b) A lead (Pb) pellet having a mass of 26.47 g at $89.98^\circ C$ was placed in a constant-pressure calorimeter of negligible heat capacity containing 100.0 mL of water. The water temperature rose from $22.50^\circ C$ to $23.17^\circ C$. What is the specific heat of the lead pellet? **(10)**
- (c) Define boiling-point elevation and freezing-point depression. Why molality is used for boiling-point elevation and freezing-point depression calculation and molarity is used in osmotic pressure calculations? **(8)**
- (d) How Jam or Jelly is preserved? Explain in the light of osmotic pressure. **(5)**

CHEM 107

7. (a) When the light from a Hydrogen gas discharge tube is separated only four lines are observed. Justify the statement according to Bohr's Theory with mathematical calculation. The value of Rydberg's constant is 2.18×10^{-18} J. (12)
- (b) Derive the de Broglie equation and from this equation explain the dual nature of microscopic objects. (7)
- (c) What is Photoelectric Effect? When light of frequency equal to $2.11 \times 10^{15} \text{ s}^{-1}$ shines on the surface of gold metal, the kinetic energy of ejected electrons is found to be 5.83×10^{-19} J. What is the threshold frequency? (8)
- (d) The electron configuration of a neutral atom is $1s^2 2s^2 2p^4$. Write a complete set of quantum numbers for each of the electrons. Name the element. (8)

8. (a) Define shielding effect and effective nuclear charge. Calculate the effective nuclear charge experienced by one of the 3p electron in potassium atom by using Slater's rule. (8)
- (b) Calculate the standard enthalpy of formation of acetylene (C_2H_2) from its elements: (12)

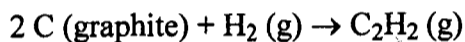

The equations for each step and the corresponding enthalpy changes are

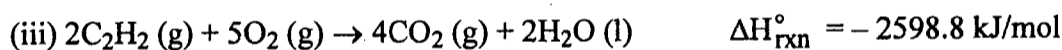

- (c) What is acid salt? Mention two examples and show their reactions with NaOH. (4)
- (d) In writing thermochemical equations, why is it important to indicate the physical state of each substance? (5)
- (e) Write the molecular equation and net ionic equation for the following reactions. (6)
- (i) Zinc sulfide with hydrochloric acid.
- (ii) Nitrous acid with sodium hydroxide.

Faiyaz Hossain
25.9.13

L-1/T-1/MME

Date : 25/09/2013

BANGLADESH UNIVERSITY OF ENGINEERING AND TECHNOLOGY, DHAKA

L-1/T-1 B. Sc. Engineering Examinations 2012-2013

Sub : **EEE 155** (Electrical Engineering Fundamentals)

Full Marks : 210

Time : 3 Hours

The figures in the margin indicate full marks.

USE SEPARATE SCRIPTS FOR EACH SECTION

SECTION - A

There are **FOUR** questions in this section. Answer any **THREE**.

1. (a) For the circuit shown in Fig. 1(a) (17)
- (i) Calculate amount of phase shift between v_i and v_o produced by the RLC network at 200 Hz.
 - (ii) State whether phase shift is leading or lagging with respect to input.
 - (iii) Determine magnitude of output when input is 120 V.

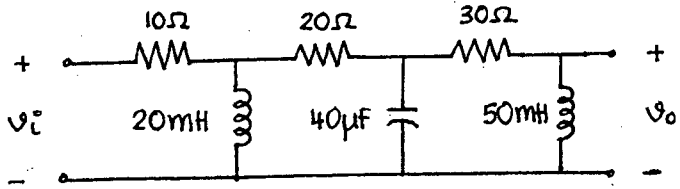

Fig. 1(a).

- (b) For the circuit shown in Fig. 1(b) (18)
- (i) Write simplified mesh equations.
 - (ii) Solve mesh equations to find total power delivered by the 100 V voltage source.

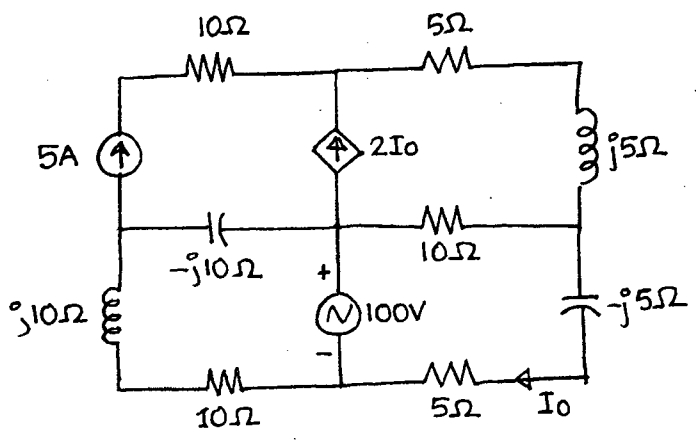

Fig. 1(b)

2. (a) Find Norton equivalent circuit at terminals a-b in the circuit of Fig. 2(a). (15)

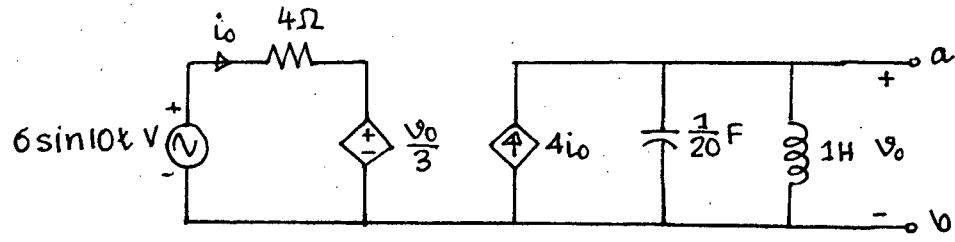

Fig. 2(a)

EEE 155 (MME)

Contd ... Q. No. 2

(b) Find i_o in the circuit shown in Fig. 2(b) using superposition theorem.

(20)

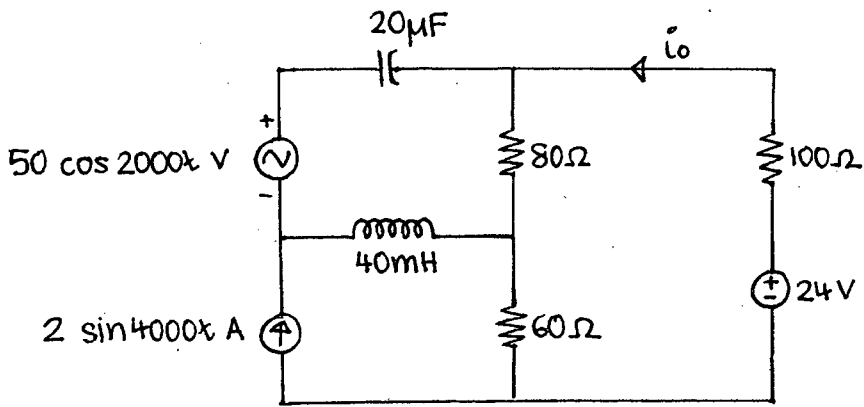

Fig. 2(b)

3. (a) Find the load impedance Z_L for the network of Fig. 3(a) for maximum power to the load, and find maximum power to the load.

(17)

(b) For the coupled coils of Fig. 3(b), calculate total inductance.

(6)

(c) Calculate the mesh currents I_1 and I_2 in the circuit of Fig. 3(c).

(12)

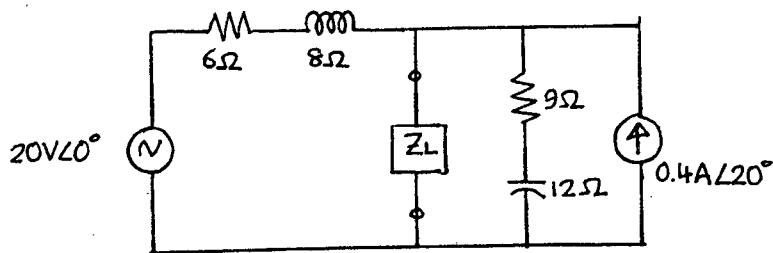

Fig. 3(a)

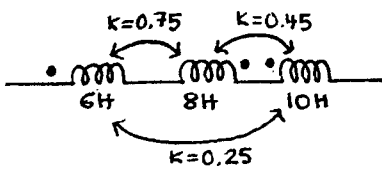

Fig. 3(b)

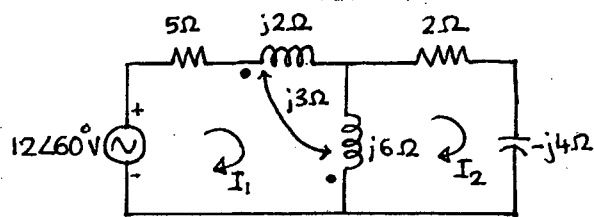

Fig. 3(c)

EEE 155 (MME)

4. (a) For the system shown in Fig. 4(a)

(20)

(i) Find the apparent power and power factor of the system.

(ii) Find value of capacitor required to raise power factor to unity.

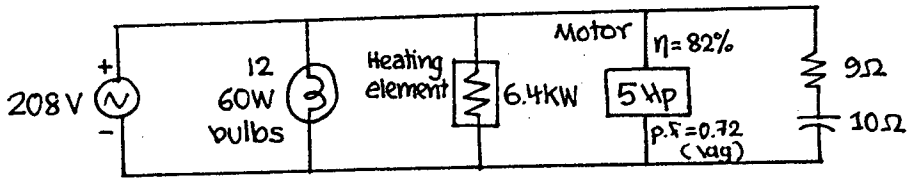

Fig. 4(a)

(b) For the Δ -Y connected load in Fig. 4(b), find the total real, reactive and apparent power. Also, find the power factor of load.

(15)

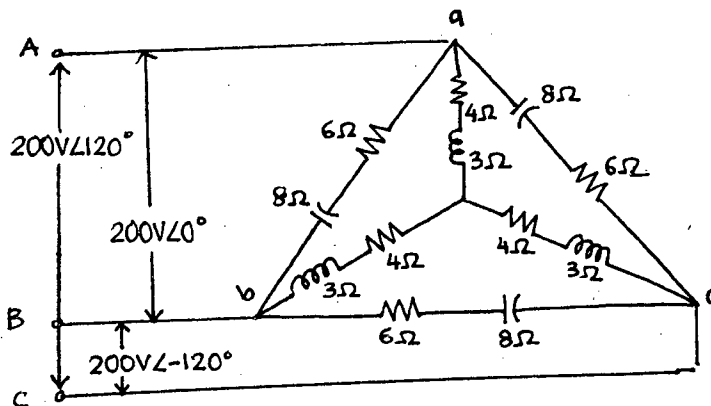

Fig. 4(b)

SECTION - B

There are **FOUR** questions in this section. Answer any **THREE**.

5. (a) If the current flowing through an element is given by

(20)

$$i(t) = \begin{cases} 2t \text{ A,} & 0 < t < 5\text{s} \\ 18 \text{ A,} & 5 < t < 10\text{s} \\ -15 \text{ A,} & 10 < t < 15\text{s} \\ 0 \text{ A,} & t > 15\text{s} \end{cases}$$

Plot the charge stored in the element over $0 < t < 20\text{s}$. Provide equation for each part of the plot.

(b) Find the equivalent resistance, R_{ab} for the circuit shown in Figure 5(b).

(15)

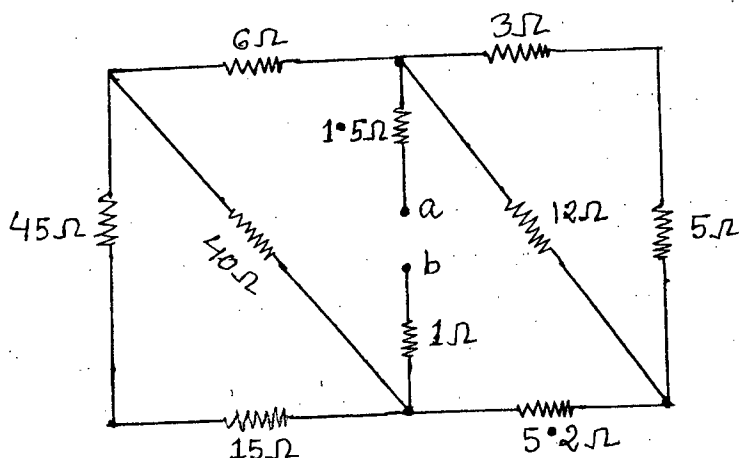

Figure 5(b)

EEE 155 (MME)

6. (a) Using nodal analysis, find v_o and I_o in the circuit shown in Figure 6(a).

(18)

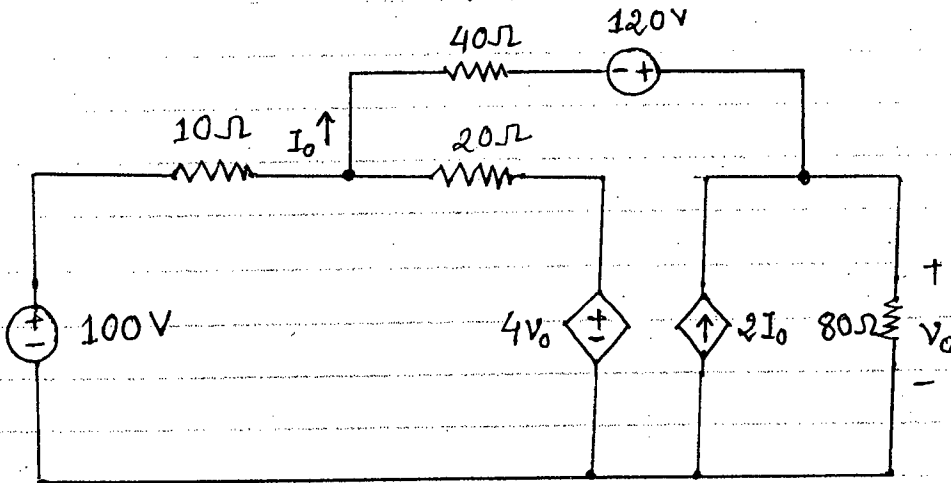

Figure 6(a)

(b) Using mesh analysis, find v_o and I_o in the circuit shown in Figure 6(b).

(17)

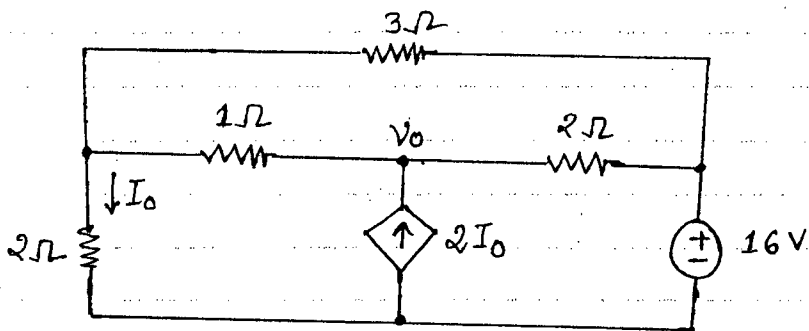

Figure 6(b)

7. (a) For the circuit shown in Figure 7(a), calculate i_x and the power dissipated by the 20 Ω resistor using superposition.

(18)

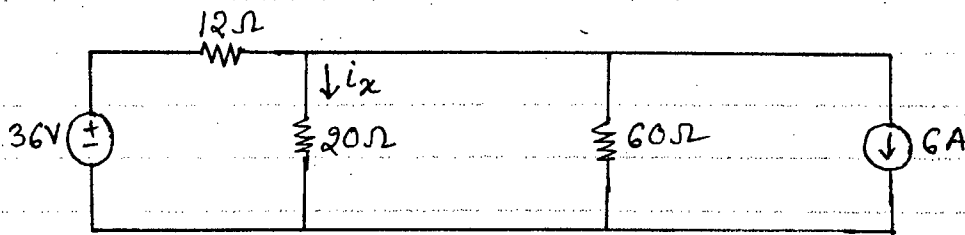

Figure 7(a)

(b) Use source transformation to find the voltage v_o , for the circuit shown in Figure 7(b).

(17)

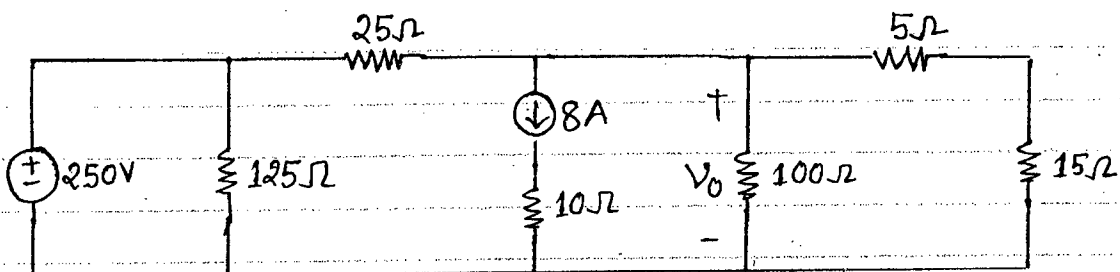

Figure 7(b)

EEE 155 (MME)

8. (a) Find the Thevenin equivalent looking into terminals a-b for the circuit shown in Figure 8(a). If a load of $18\ \Omega$ is connected between a-b, find the load current. (17)

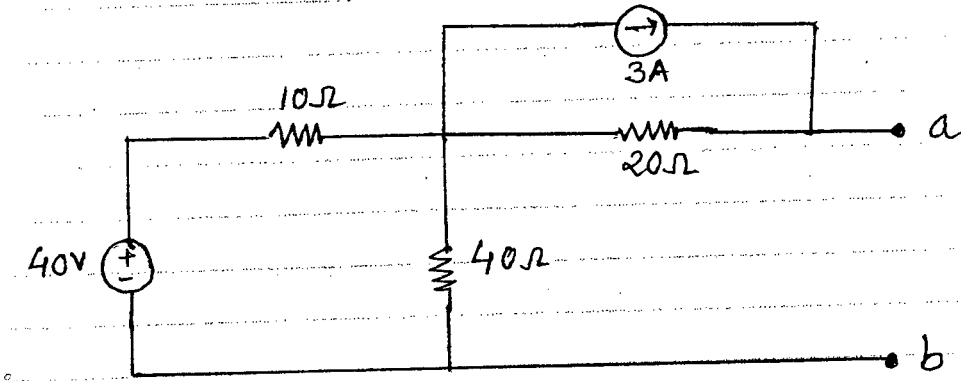

Figure 8(a)

- (b) For the circuit shown in Figure 8(b), for what value of R, maximum power will be dissipated in it? Calculate that power. (18)

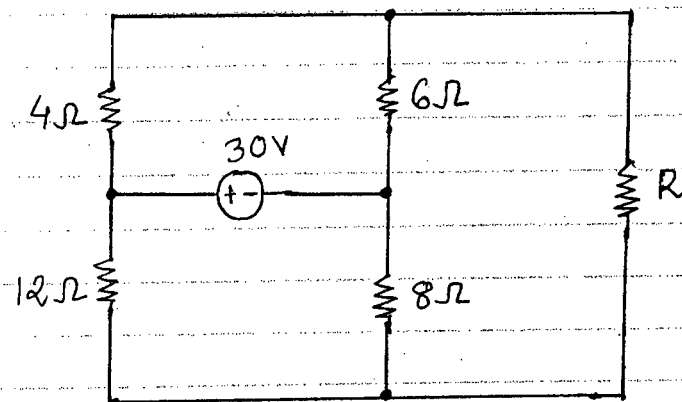

Figure 8(b)

Isma

L-1/T-1/MME

Date : 27/07/2013

BANGLADESH UNIVERSITY OF ENGINEERING AND TECHNOLOGY, DHAKA

L-1/T-1 B. Sc. Engineering Examinations 2012-2013

Sub : **MME 131** (Introduction to Metallurgy and Materials)

Full Marks : 210

Time : 3 Hours

The figures in the margin indicate full marks.

USE SEPARATE SCRIPTS FOR EACH SECTION

SECTION – A

There are **FOUR** questions in this Section. Answer any **THREE**.

1. (a) What information may be obtained from an equilibrium diagram? (10)
(b) Bismuth and antimony are completely soluble in both the liquid and solid states. Bismuth melts at 520°F and antimony melts at 1170°F. (25)
 - (i) Draw a hypothetical equilibrium diagram on a piece of graph paper and label all points, lines and areas.
 - (ii) For an alloy containing 40 percent antimony-
 - (a) Find the temperature of initial solidification
 - (b) Find the temperature of final solidification
 - (c) Find the chemical composition and relative amounts of the phases present at 800°F.
2. (a) List the nondestructive tests that are generally applied to detect defects. With the aid of sketches discuss how magnetic particle inspection can be used to detect defects. (18)
(b) Explain the difference between through transmission and pulse-echo methods of ultrasonic inspection. What are the limitations of ultrasonic inspection? (17)
3. (a) Describe the sources of scrap metal. (15)
(b) Discuss the steps involved in hydrometallurgical processing. What are the advantages and disadvantages of hydrometallurgical processing? (20)
4. (a) Classify the fabrication techniques of metals. Describe, with neat sketches, the different types of forming operations. (20)
(b) 'The term Iron Age has low chronological value'- why? (5)
(c) How was Copper discovered by early man? (10)

SECTION – B

There are **FOUR** questions in this Section. Answer any **THREE**.

5. (a) What are semiconductors? Write down some of their distinguishing features and applications. (7)
(b) Explain the glass forming process with the help of diagrams. (13)
(c) What are the four conditions that must be satisfied to form a complete solid solution? (8)
(c) What are dislocations? (7)

Contd P/2

MME 131

6. (a) Calculate the atomic packing factor of a FCC and HCP crystal structure. (20)
(b) Describe with the help of diagrams, a fabrication technique used for producing complex ceramic shapes. (15)
7. (a) What is ductile to brittle transition? Describe your answer with the help of a labelled diagram. (15)
(b) With the help of a S-N curve explain what you understand by fatigue strength and fatigue life. Describe in detail, the three stages of fatigue failure. (20)
8. (a) What do you understand by creep? Explain the different stages in the creep strain (ϵ) Vs time curve with the help of a labelled diagram. (20)
(b) Explain with the help of diagrams, how necking eventually leads to final shear fracture. (10)
(c) Write a short note on strain hardening. (5)
-

Said

L-1/T-1/MME

Date : 07/10/2013

BANGLADESH UNIVERSITY OF ENGINEERING AND TECHNOLOGY, DHAKA

L-1/T-1 B. Sc. Engineering Examinations 2012-2013

Sub : **PHY 103** (Optics, Waves and Oscillations)

Full Marks : 210

Time : 3 Hours

The figures in the margin indicate full marks.

USE SEPARATE SCRIPTS FOR EACH SECTION

SECTION – A

There are **FOUR** questions in this Section. Answer any **THREE**.

1. (a) What is interference of light? How is the law of conservation of energy obeyed in interference? (8)
- (b) Explain clearly the theory and the experimental arrangement of Newton's rings experiment. Why the central spot in Newton's rings due to reflected light is dark? (20)
- (c) A Newton's rings apparatus is used to determine the radius of curvature of a lens. The radii of the n th and $(n + 20)$ th bright rings are measured and are found to be 0.162 cm and 0.368 cm, respectively, in the light of wavelength 546 nm. Calculate the radius of curvature of the lower surface of the lens. (7)
2. (a) What is a diffraction grating? Write down the equation of a diffraction grating by mentioning each term. (7)
- (b) Explain the Fraunhofer diffraction pattern produced by a single narrow slit illuminated by a monochromatic light. (20)
- (c) In a single slit diffraction pattern, the distance between the first minimum on the right and the first minimum on the left is 5.20 mm. The screen on which the pattern is displayed is 82.3 cm from the slit and the wavelength is 546 nm. Calculate the slit width. (8)
3. (a) What is polarization of light? What does it suggest about the nature of light? (7)
- (b) Describe a Nicol prism and show how it can be used for the study of polarization of light. (18)
- (c) Find the specific rotation of a given sample of sugar solution if the plane of polarization is turned through 26.4° . The length of the tube containing 20% sugar solution is 20 cm. (10)
4. (a) What are the common defects in the images produced by a single lens? Explain them with optical diagrams. (22)
- (b) Show that the longitudinal chromatic aberration in a lens is equal to the product of the dispersive power of the material of the lens and its focal length. (8)
- (c) Using the condition of achromatism of two lenses (convex + concave) in contact, show that the combined lens behaves as a plane glass when they are made of the same material. (5)

PHY 103(MME)

SECTION – B

There are **FOUR** questions in this Section. Answer any **THREE**.

5. (a) Show diagrammatically the cardinal points of a thick lens. (3 ½)

(b) Prove that the distance between nodal points is equal to the distance between principal points. Also prove that the nodal points coincide if the refractive indices on either side of the lens are the same. (6+6 ½=12 ½)

(c) Two thin converging lenses of focal lengths f_1 and f_2 are coaxial and are separated by a distance d . Show that the equivalent focal length, f , of the combined lens is given by the relation: (14)

$$f = \frac{f_1 f_2}{f_1 + f_2 - d}$$

(d) An object is 40 cm to the left of a lens with focal length of 20 cm. A second lens of focal length 25 cm is 60 cm to the right of the object. Find the power of the combined lens. (5)

6. (a) Differentiate between monochromatic and chromatic aberrations. (4)

(b) Obtain an expression for Cauchy's dispersion formula, relating the refractive index to the wavelength of light and hence justify the fact that red ray is deviated less than blue ray. (26)

(c) Calculate the values of Cauchy's constants 'A' and 'B' from the following data of crown (C) and flint (F) glasses: (5)

$$n_C = 1.514 ; \lambda_C = 6563 \text{ \AA}$$
$$n_F = 1.524 ; \lambda_F = 4862 \text{ \AA}$$

7. (a) Define simple harmonic motion. What is a torsion pendulum? Show that for small angular displacement the oscillation of a torsion pendulum is simple harmonic. (12)

(b) Show that for a body executing simple harmonic motion total mechanical energy remains conserved. (11)

(c) A particle executing simple harmonic motion about the point $x = 0$. At time $t = 0$ its displacement is 0.5 cm and velocity is zero. It takes 0.4 seconds to move from zero velocity to maximum velocity. Determine (i) the amplitude, (ii) the time period, (iii) The maximum speed (iv) the displacement where the energy is half kinetic and half potential. (12)

PHY 103(MME)

8. (a) What are the characteristics of a mechanical wave? Derive the one dimensional differential equation of a progressive wave. **(10)**
- (b) What is meant by the principle of superposition of waves? Use it to explain the formation of stationary waves due to reflection at a rigid boundary. Show that at the positions of antinodes strain is minimum. **(13)**
- (c) A progressive wave of amplitude 0.5 cm, frequency 1000 Hz and wavelength 80 cm and travelling along +x direction is reflected at a rigid boundary and produces four loops. **(12)**
- (i) Write down the displacement equations of the incident and reflected waves,
 - (ii) Calculate the length between the incident and the reflected points,
 - (iii) How many nodes are within this length and determine their positions.
-