

Handwritten signature and date: 12-01-13

The figures in the margin indicate full marks.

USE SEPARATE SCRIPTS FOR EACH SECTION

SECTION - A

There are **FOUR** questions in this section. Answer any **THREE**.

1. (a) How do the practical voltage and current sources differ from ideal voltage and current sources. (10)

- (b) Calculate all the branch currents I_1 -to- I_5 in the following circuit in Fig. for Q. 1(b). (20)

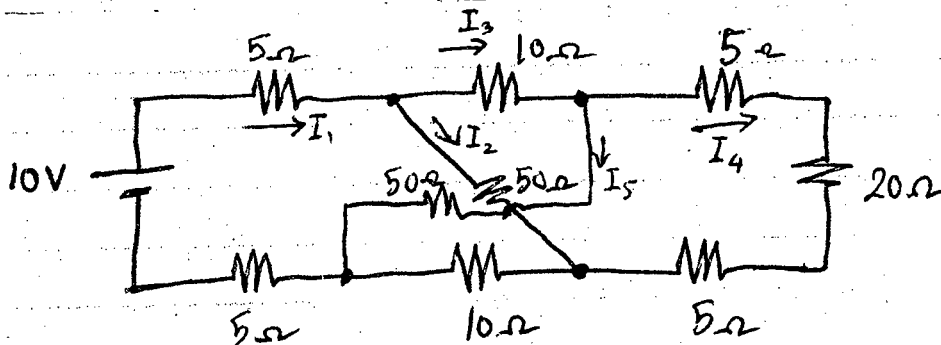

Fig. for Q. 1(b)

- (c) Write down the statements of Kirchoff's voltage and current laws. (5)
2. (a) Show that, maximum power transfer occurs when the load resistance equals the line resistance. (10)
- (b) Use the mesh-current method to find the power developed in the dependent voltage source in the following circuit in Fig. for Q. 2(b). (25)

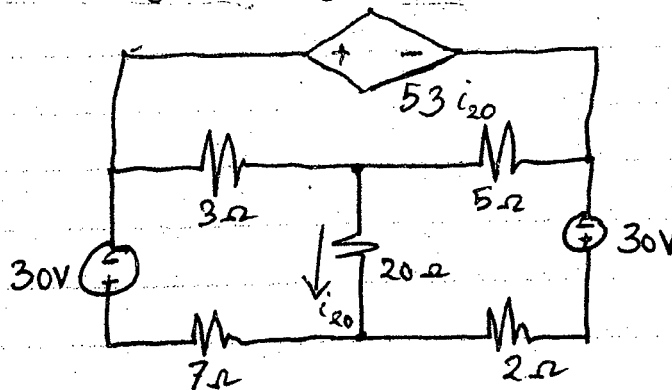

Fig. for Q. 2(b)

3. (a) A certain dc circuit yields a measured value of 75 V at the terminals with no load connected to the source. The same system yields a terminal voltage of 60 V when a 20 Ω load is connected. What is the Thevenin equivalent resistance with respect to the terminals of dc circuit? (10)

Contd P/2

= 2 =

EEE 163

Contd ... Q. No. 3

(b) Find the power dissipated in $10\ \Omega$ (P_{10}) and $1\ \Omega$ (P_1) resistor in Fig. for Q. 3(b). (25)

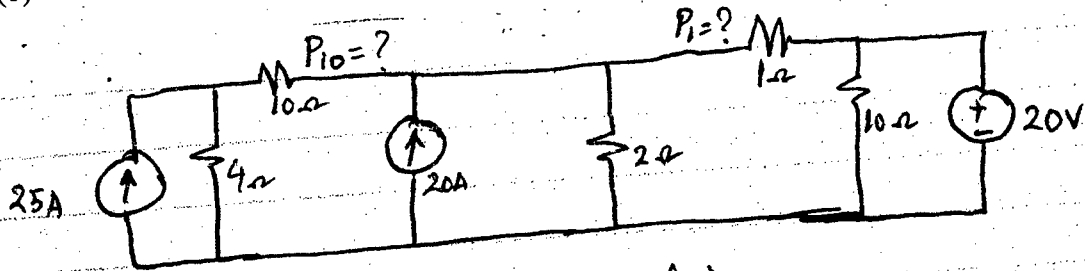

Fig. for Q. 3(b)

4. (a) For the following circuit, find the power delivered to R_0 in Fig. for Q. 4(a). (23)

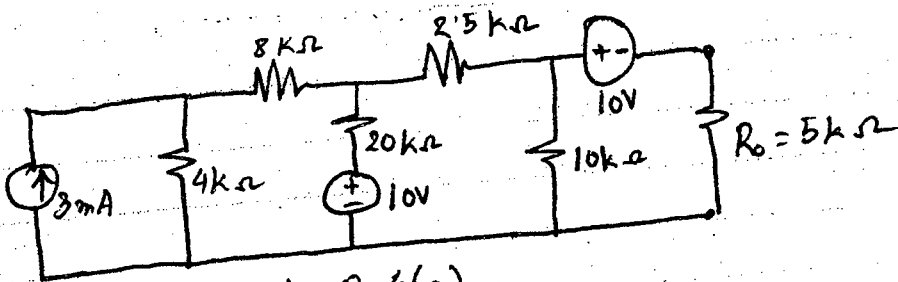

Fig. for Q. 4(a)

(b) Show that, for a Δ -Y equivalent circuit, $R_\Delta = 3R_Y$. (12)

SECTION - B

There are **FOUR** questions in this section. Answer any **THREE**.

5. (a) Assume that the current $i(t) = I_m \sin \omega t$ flows through a series R-C branch. Derive the expressions for applied voltage, impedance, instantaneous power, real power and reactive power. Also draw the waveshape for power. (20)

(b) Find the average and r.m.s. values for the waveform shown in figure 5(b). (15)

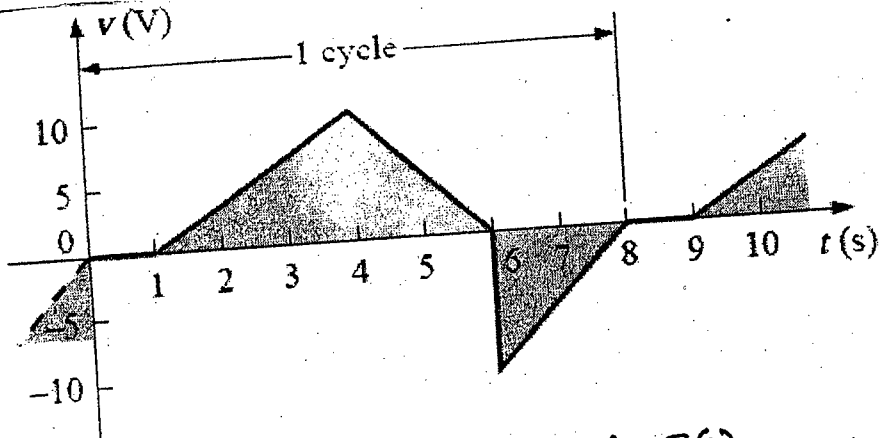

Fig. for Q. No. 5(b)

EEE 163

(25)

6. (a) For the network shown in Figure 6(a):

- (i) Find the current I
- (ii) Find the voltage V_c
- (iii) Find the average power delivered to the network
- (iv) Draw the phasor diagram showing all the voltages
- (v) Write the expression for $V_c(t)$ if the network is operating at 50 Hz.

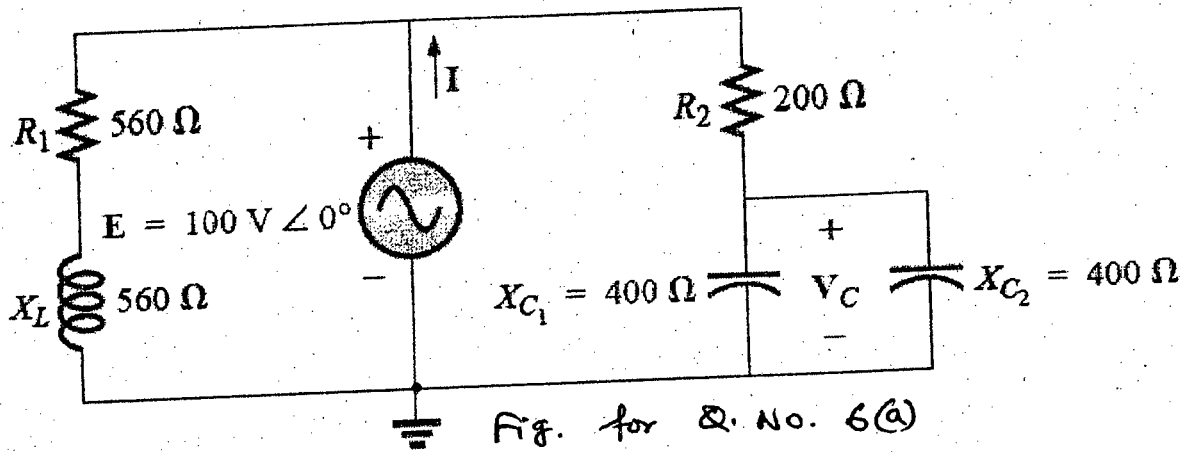

(b) Find Z_{eq} of the circuit shown in the Fig. 6(b).

(10)

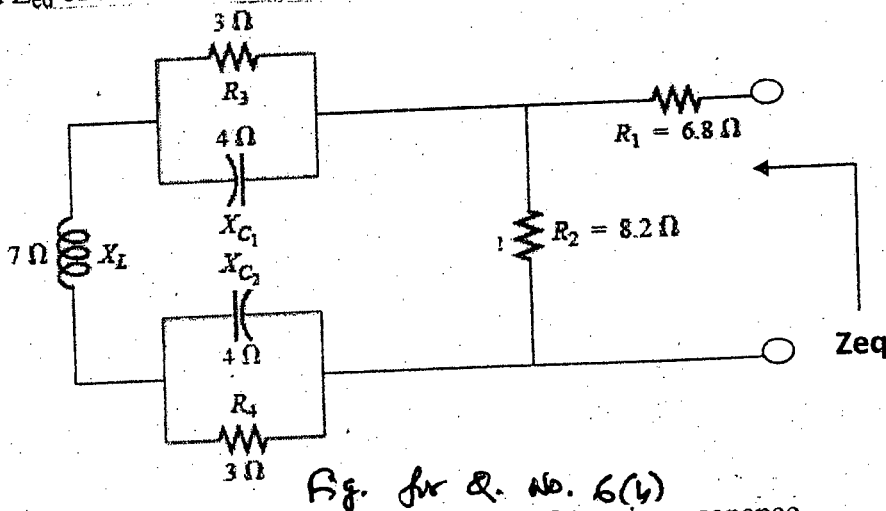

7. (a) Derive the expressions of cut-off frequencies for series resonance.

(15)

(b) For the network shown in Fig. 7(b):

- (i) Determine Q_b , R_p and Z_{Tp} , where the symbols have their usual meaning.
- (ii) Find C at resonance
- (iii) Find Q_p and the bandwidth.

(20)

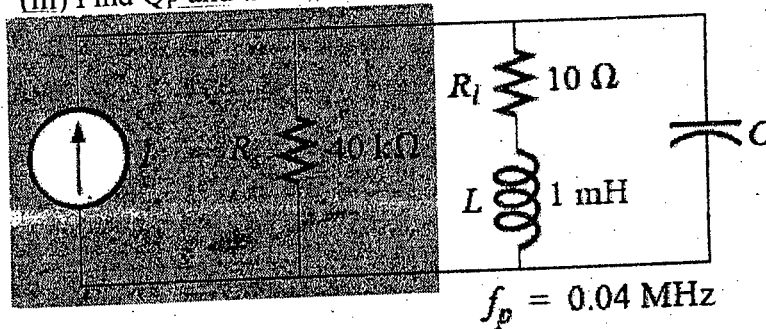

Contd P/4

EEE 163

8. (a) Briefly explain the hysteresis curve.

(10)

(b) For the series-parallel magnetic circuit of Fig. 8(b), find the value of I required to establish a flux in the gap of $\phi_g = 2 \times 10^{-4}$ wb. (B-H curve for different material is given in the figure B-H curve for Q. No. 8(b)).

(25)

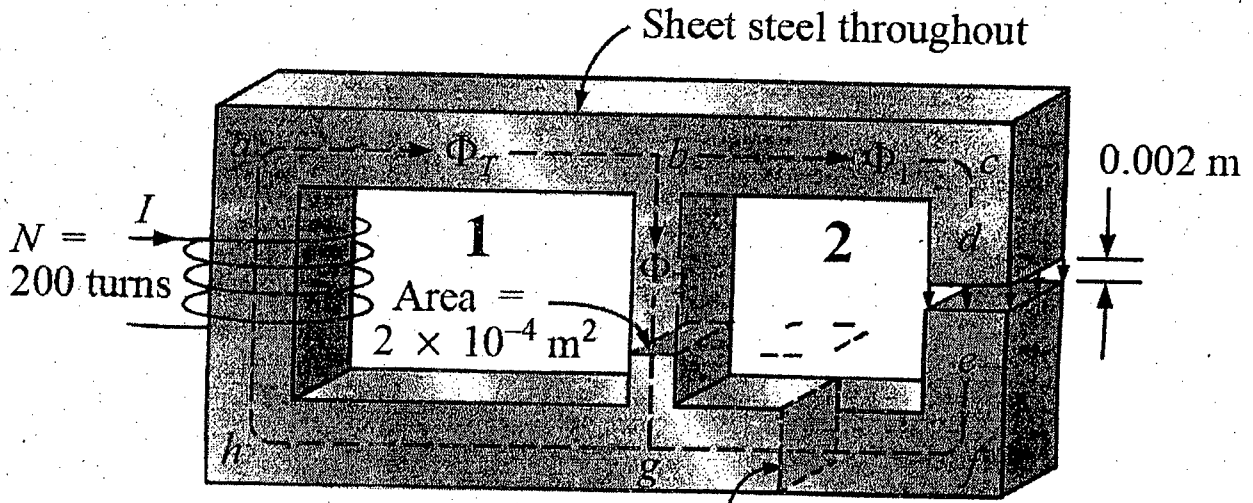

Area for sections other than $bg = 5 \times 10^{-4} \text{ m}^2$

$$l_{ab} = l_{bg} = l_{gh} = l_{ha} = 0.2 \text{ m}$$

$$l_{bc} = l_{fg} = 0.1 \text{ m}, l_{cd} = l_{ef} = 0.099 \text{ m}$$

Fig. for Q. no. 8(b)

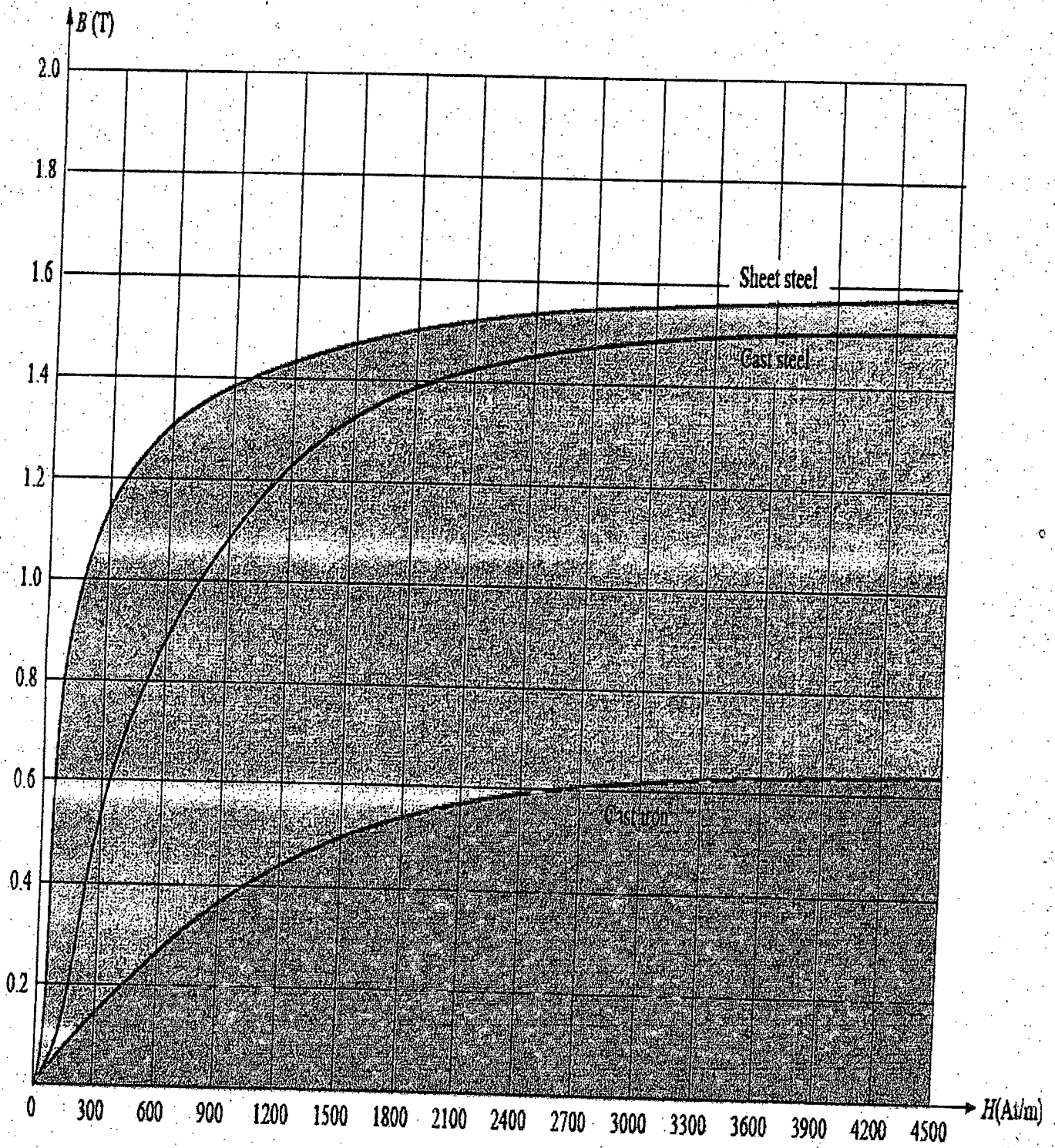

Fig. B-H curve for Q. No - 8(b)

Glazman

L-1/T-1/CSE

Date : 05/01/2013

BANGLADESH UNIVERSITY OF ENGINEERING AND TECHNOLOGY, DHAKA

L-1/T-1 B. Sc. Engineering Examinations 2011-2012

Sub : **PHY 109** (Heat and thermodynamics, structure of matter, waves & oscillation and physical optics)

Full Marks: 280

Time : 3 Hours

USE SEPARATE SCRIPTS FOR EACH SECTION

The figures in the margin indicate full marks.

SECTION - A

There are **FOUR** questions in this section. Answer any **THREE**.

1. (a) Distinguish between crystalline and amorphous solids. Among them which one is more stable and why? (9)
(b) Explain polymorphism with some examples. What is graphene? (4)
(c) What are the lattice parameters of a 3D unit cell? What are Bravais lattices and crystal system? Mention all 3D Bravais lattices with their crystal system and lattice parameters. (20)
(d) Derive the relationships between unit cell edge length and atomic radius for face centered cubic and body centered cubic crystal structures. (10)
(e) Unit cell edge length of gold crystal is 0.4080 nm. How many unit cells are in a gold foil of length 2 cm, breadth 2 cm and thickness 0.02 mm? (3²/₃)

2. (a) Why the interatomic or intermolecular bonds exist in solids? Briefly describe various types of bond in solids. (10)
(b) Distinguish between lattice energy and cohesive energy of an ionic crystal. Derive an expression for lattice energy for a typical ionic crystal. (20)
(c) Define co-ordination number. What are the co-ordination numbers of (i) simple cubic, (ii) body centered cubic, and (iii) face centered cubic crystals. Explain with the help of neat sketches. (10)
(d) What is crystalline nature of nickel? Sketch (100) plane of nickel crystal. Atomic radius of nickel is 0.1248 nm. (6²/₃)
(i) what is the area of this plane? (ii) calculate number of atoms/mm² of (100) plane of nickel crystal. Calculate packing factor for nickel crystal.

3. (a) State the considerations which led van der Waals to modify the equation for a real gas. (10)
(b) Derive van der Waals equation for a real gas. Obtain expressions for the critical volume (V_c), pressure (P_c) and temperature (T_c) for real gas. (28)
(c) Calculate van der Waals constants for dry air, given that T_c = 132 K, P_c = 37.2 atmospheres, and R = 8.3 J K⁻¹ mole⁻¹. (8²/₃)

4. (a) Explain thermodynamic functions H, F and G for a system with constant composition. (10)
(b) Derive following Maxwell's thermodynamic relation: (28)
$$\left(\frac{\partial S}{\partial V}\right)_T = \left(\frac{\partial P}{\partial T}\right)_V$$

(c) Deduce clapeyron's latent heat equation from Maxwell's thermodynamic relation. (8²/₃)

Contd P/2

PHY 109

SECTION – B

There are **FOUR** questions in this Section. Answer any **THREE**.

5. (a) Establish the differential equation for simple harmonic motion and solve it to obtain the expression for the displacement. (20 $\frac{2}{3}$)
- (b) Two oscillating bodies of masses m_1 and m_2 are connected by a spring on a horizontal frictionless surface. Show that their relative motion can be represented by the oscillation of a simple body having reduced mass μ . (16)
- (c) Two masses $m_1 = 3.0$ kg and $m_2 = 4.0$ kg are connected by a spring. Given that the extension of the spring is 1.0 cm for the applied force of 2.5 Newton. (10)
- (i) What is the frequency of the two body system? (10)
- (ii) What is the ratio of kinetic energies $\left(\frac{k_1}{k_2}\right)$ of two bodies? (10)
6. (a) Define phase velocity and group velocity of waves. Establish a relation between the two in a dispersive medium and show that they are same in a non-dispersive medium. (22 $\frac{2}{3}$)
- (b) Discuss analytically the formation of stationary waves in an open end organ pipe and show that the amplitude, velocity, acceleration and strain or compression vary with position and time. (16)
- (c) A sound wave in air, having an amplitude of 0.0075 cm and frequency 700 Hz traveling along the direction of positive x-axis with a velocity of 350 m/sec suffers reflection at a free boundary. What is the resultant amplitude at a point $x = 50$ cm? (8)
7. (a) What is interference of light? Mention the necessary conditions for observing interference of light. What are coherent sources? (13)
- (b) What do you mean by 'Newton's rings'? Describe with necessary theory the Newton's rings method of measuring wavelength of light. Why the central spot is dark in Newton's rings formed by the reflected light? (25 $\frac{2}{3}$)
- (c) In a Newton's rings experiment the diameter of the 15th ring was found to be 0.590 cm and that of the 5th ring was 0.336 cm. If the radius of the plano-convex lens is 100 cm, calculate the wavelength of light used. (8)
8. (a) What is diffraction of light? Obtain an expression for the intensity distribution due to Fraunhofer diffraction at a single slit. (20 $\frac{2}{3}$)
- (b) What is plane polarized light? Explain the Malu's law. How will you orient the polarizer and the analyzer so that a beam of natural light is reduced to (i) 0.25, (ii) 0.5 and (iii) 0.75 of its original intensity? (16)
- (c) Define the following terms (10)
- (i) Quarter and half-wave plates
- (ii) Specific rotation.
-

Diplo

L-1/T-1/CSE

Date : 23/12/2012

BANGLADESH UNIVERSITY OF ENGINEERING AND TECHNOLOGY, DHAKA

L-1/T-1 B. Sc. Engineering Examinations 2010-2011

Sub : **ME 165** (Basic Mechanical Engineering)

Full Marks : 210

Time : 3 Hours

The figures in the margin indicate full marks.

USE SEPARATE SCRIPTS FOR EACH SECTION

SECTION – A

There are **FOUR** questions in this Section. Answer any **THREE**.

Assume reasonable values for any missing data.

1. (a) The beam OA carries a load P and is supported by two cables as shown in Fig. for Q. No. 1(a). Knowing that the tension in cable AB is 732 N and that the resultant of the load P and of the forces exerted at A by the two cables must be directed along OA, determine (i) the tension in cable AC, (ii) the value of load P. (18)
- (b) As shown in Fig. for Q. No. 1(b), the 5 m boom AB has a fixed end A. A cable is stressed from the free end B of the boom to point C located on the vertical wall. If the tension in the cable is 2.5 kN, determine the moment about A of the force exerted by the cable at B. Also determine the angles of the direction of moment with the coordinates. (17)
2. (a) Find the forces in the members CD and DB of the truss as shown in Fig. for Q. No. 2(a) by the method of section. State whether the members are in tension or compression. (17)
- (b) In the frame shown in Fig. for Q. No. 2(b), member ACE and BCD are connected by a pin at C and by the link DE. For the loading shown, determine the force in link DE and the force exerted at C on member BCD. (18)
3. (a) The lever AB is hinged at C and attached to a control cable at A as shown in Fig. for Q. No. 3(a). If the lever is subjected at B to a 1.5 kN horizontal force, determine, (i) the tension in the cable (ii) the reaction at point C. (17)
- (b) Two wires AC and BC are tied at C to a sphere which revolves at a constant speed in the horizontal circle as shown in Fig. for Q. No. 3(b). Determine the range of values of speed for which both wires remain taut. (18)
4. (a) In the position shown in Fig. for Q. No. 4(a), bar AB has a constant angular velocity of 5 rad/s counterclockwise. Determine the angular velocity of bars BD and DE. (17)
- (b) Give a brief description on the main components of a robot. (10)
- (c) What is meant by robot coordinates? With a neat sketch explain the working space of a cylindrical coordinate robot. (8)

ME 165(CSE)

SECTION – B

There are **FOUR** questions in this Section. Answer any **THREE**.

5. (a) What is fossil fuel? What are the forms of fossil fuels? How long are the current fossil fuels reserve expected to be able to meet up the estimated energy demand in the world? (10)
- (b) What is renewable energy? What are the renewable energy sources currently used for electric power generation in Bangladesh? (8)
- (c) Biomasses like wood, leaf, rice husk, etc. are popular solid fuels in rural areas. These biomasses are considered renewable energy source. Why? (7)
- (d) Differentiate between SI and CI engines. (10)
6. (a) With necessary sketches, briefly describe the working principle of a four stroke IC engine. (18)
- (b) Diameter (bore) of each cylinder of a four stroke IC engine is 10 cm. Stroke length is 10 cm. Clearance volume is 100π cc i.e. 314 cc. (12)
- (i) What is the total volume (in cc) of each cylinder?
- (ii) What is the compression ratio?
- (iii) What type of IC engine is it? SI or CI?
- (iv) IF there are 4 cylinders in the engine, what will be the cc of the engine?
- (c) Draw the actual as well as the ideal thermodynamic cycle of a gasoline or petrol engine and show the thermodynamic processes. (5)
7. (a) With necessary sketches, describe the operating principle of an closed loop gas turbine. Draw the corresponding thermodynamic cycle. (18)
- (b) With necessary T-S diagrams explain the merits of adding regeneration, inter-cooling and reheating processes in a closed loop gas turbine. (17)
8. (a) Differentiate between natural cooling and refrigeration. (7)
- (b) Define ton of refrigeration. (6)
- (c) Draw the Vapor Compression Refrigeration system and the corresponding ph diagram. Label the diagrams. (10)
- (d) The dry and wet bulb temperatures in a room are recorded to be 30°C and 25°C, respectively. (12)
- (i) Determine humidity ratio, relative humidity, specific enthalpy, specific volume and dew point.
- (ii) An airconditioner is used to change the room condition to have 25°C dry bulb temperatures and 50% relative humidity. Determine the new humidity ratio, wet bulb temperature and specific enthalpy.
- (iii) Determine the amount of heat and water removed from the room?
-

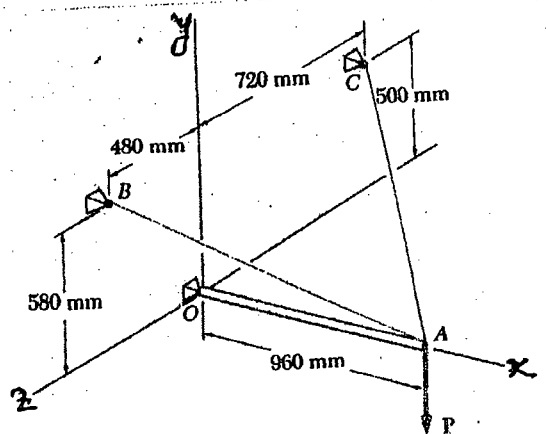

Fig. for Q. No. 1(a)

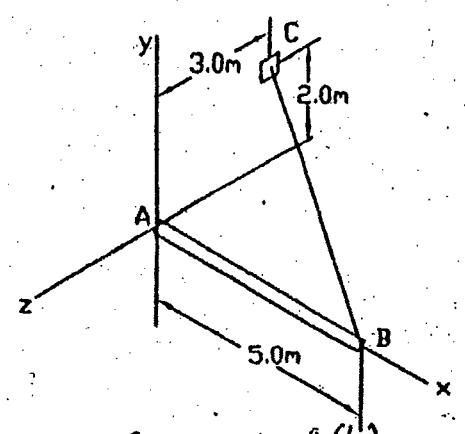

Fig. for Q. No. 1(b)

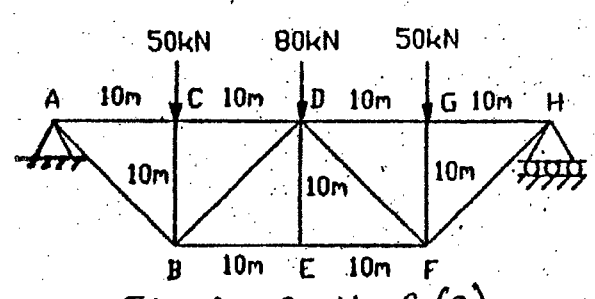

Fig. for Q. No. 2(a)

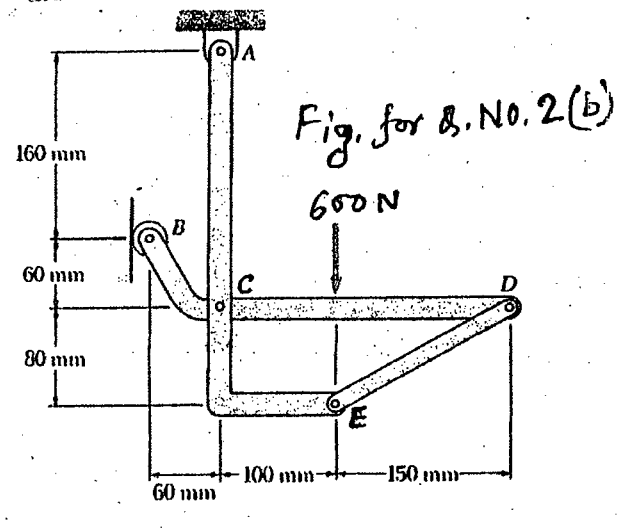

Fig. for Q. No. 2(b)

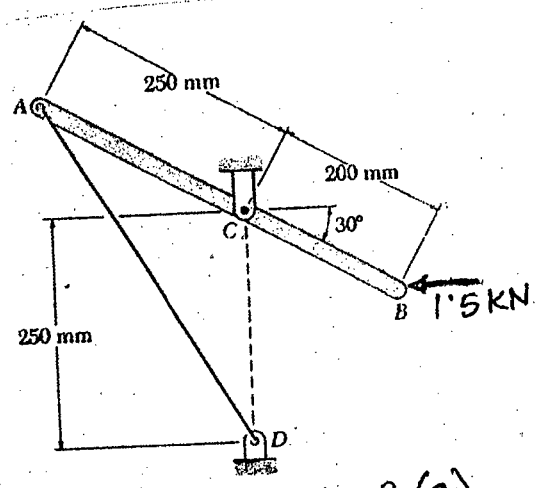

Fig. for Q. No. 3(a)

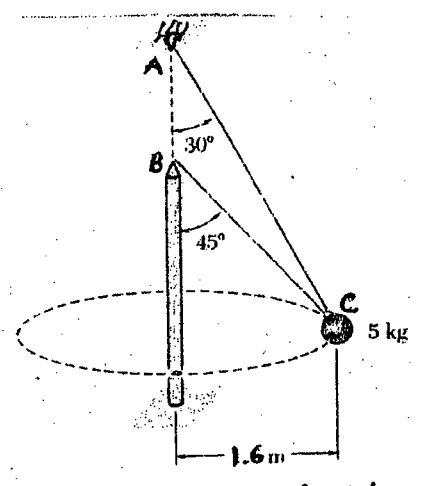

Fig. for Q. No. 3(b)

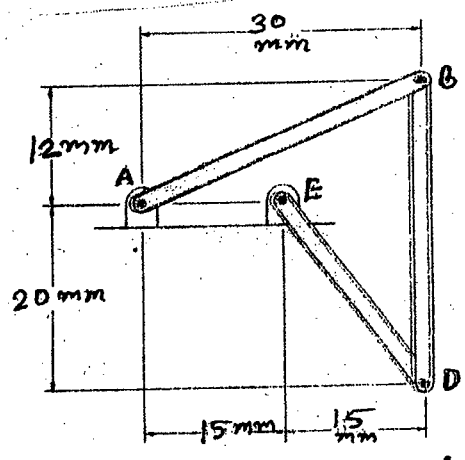
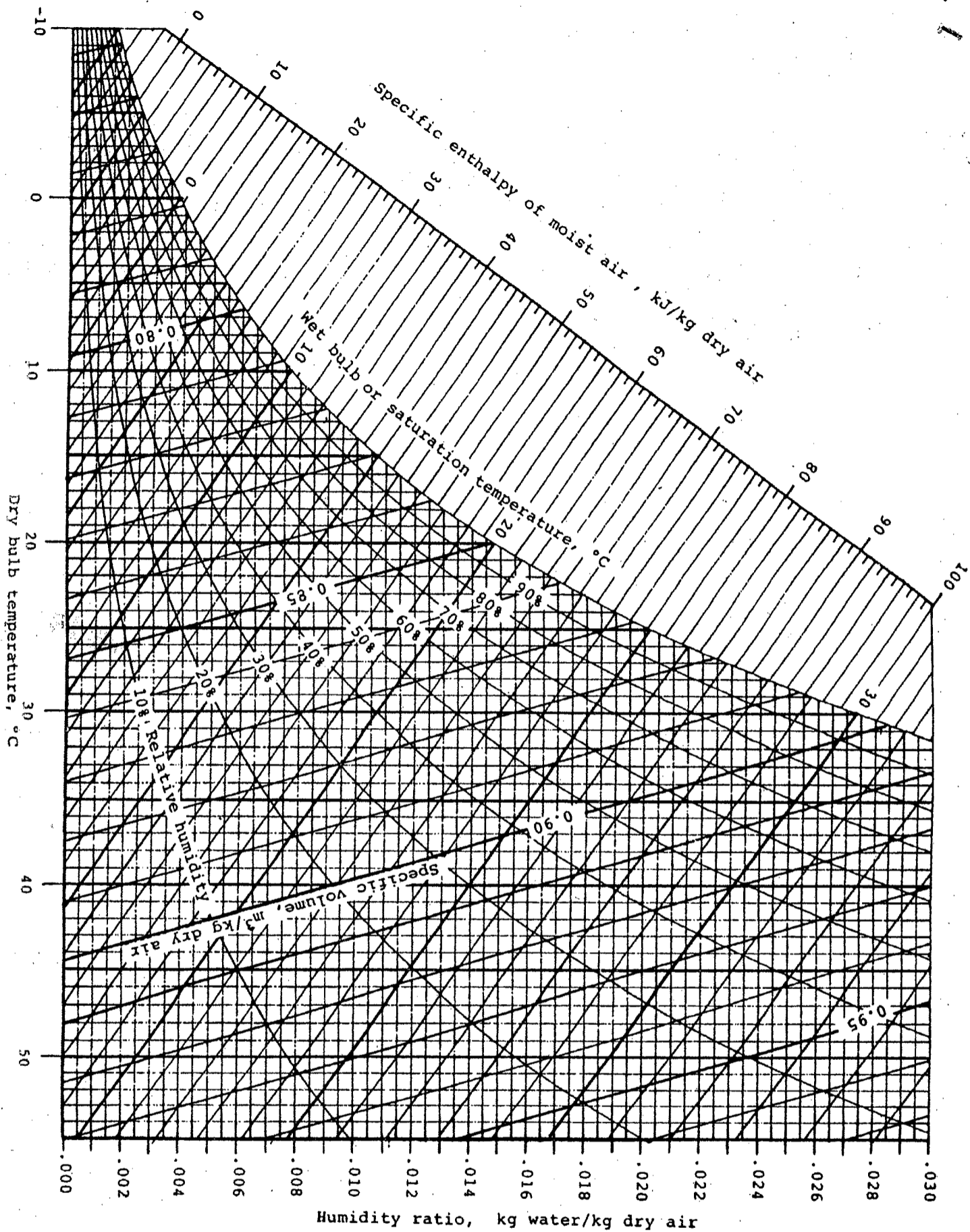

Fig. for Q. No. 4(a)



Handwritten note:
 15/12/12
 Morning

SECTION - AThere are **FOUR** questions in this Section. Answer any **THREE**.

Symbols have their usual meaning.

1. (a) A function
- $f(x)$
- is defined as follows:

(25)

$$f(x) = \begin{cases} 1+x & \text{when } x \leq 0 \\ x & \text{when } 0 < x < 1 \\ 2-x & \text{when } 1 \leq x \leq 2 \\ 2x-x^2 & \text{when } x > 2 \end{cases}$$

Sketch the graph of $f(x)$ and discuss the continuity and differentiability of $f(x)$ at $x = 1$ and $x = 2$.

(b) Find $\lim_{x \rightarrow 0} (\cos x)^{\frac{1}{x^2}}$.

(10)

2. (a) If
- $y = \sin(a \sin^{-1}x)$
- , then show that
- $(1-x^2)y_{n+2} - (2n+1)xy_{n+1} - (n^2-a^2)y_n = 0$
- and find the value of
- $(y_n)_0$
- .

(13)

(b) Find the condition that the curves $x^{\frac{2}{3}} + y^{\frac{2}{3}} = c^{\frac{2}{3}}$ and $\frac{x^2}{a^2} + \frac{y^2}{b^2} = 1$ may touch.

(12)

(c) Find the radius of curvature of the curve $\sqrt{x} + \sqrt{y} = \sqrt{a}$ at the point where $y = x$ cuts it.

(10)

3. (a) State and prove Rolle's Theorem. A function is defined as follows:

(15)

$$f(x) = \begin{cases} x, & 0 \leq x \leq 1 \\ -x, & -1 \leq x \leq 0 \end{cases}$$

Is Rolle's theorem applicable to the function $f(x)$ in $-1 \leq x \leq 1$.

(b) Verify the Mean Value Theorem for the function $f(x) = Ax^2 + Bx + C$ in the interval (a, b) .

(10)

(c) If $u = \tan^{-1} \frac{x^3 + y^3}{x + y}$, then show that $x \frac{\partial u}{\partial x} + y \frac{\partial u}{\partial y} = \sin 2u$.

(10)

4. (a) Find the area of the triangle formed by the asymptotes of the curve

$$(x^2 - y^2)y - 2ay^2 + 5x - 7 = 0.$$

(15)

(b) If $y = (2x + 3)^2 (3x - 1)^2$, determine the nature of the stationary points.

(12)

(c) Find the interval on which the function $f(x) = x^3 - 12x + 4$ is concave up and concave down.

(8)

= 2 =

MATH 141(CSE)**SECTION - B**There are **FOUR** questions in this section. Answer any **THREE**.

5. (a) Transform the equation $11x^2 + 24xy + 4y^2 - 20x - 40y - 5 = 0$ to one in which there is not term involving x , y and xy , both sets of axes being rectangular. (15)

- (b) Find the angle between the lines joining the origin to the intersection of the curve $x^2 + y^2 + 19x + 4y - 3 = 0$ and the line $3x + 4y = 1$. (10)

- (c) If one of the lines $ax^2 + 2hxy + by^2 = 0$ be perpendicular to one of the lines $a'x^2 + 2h'xy + b'y^2 = 0$ prove that $(aa' - bb')^2 + 4(a'h + bh')(ah' + b'h) = 0$. (10)

6. (a) If $ax^2 + 2hxy + by^2 + 2gx + 2fy + c = 0$ represents a pair of straight lines, show that the area of the triangle formed by their bisectors and the axis of x is

$$\frac{\sqrt{(a-b)^2 + 4h^2}}{2h} \cdot \frac{ac - g^2}{ab - h^2}. \quad (15)$$

- (b) Find the coordinates of the limiting points of the co-axial system determined by the circles $x^2 + y^2 + 4x + 2y + 5 = 0$ and $x^2 + y^2 + 2x + 4y + 7 = 0$. (10)

- (c) Find the locus of the point of intersection of the tangents at the extremities of any chord of the parabola $y^2 = 4ax$, which subtends a right angle at the vertex. (10)

7. (a) Find the locus of the points such that two of the three normals from them to the parabola $x^2 = 8ay$ are at right angles to one another. (17)

- (b) Show that the locus of the points of intersection on the normals drawn at the extremities of two conjugate diameters of the ellipse $\frac{x^2}{a^2} + \frac{y^2}{b^2} = 1$ is the curve $2(a^2x^2 + b^2y^2)^3 = (a^2 - b^2)^2 (a^2x^2 - b^2y^2)^2$. (18)

8. (a) Reduce the equation $x^2 + 12xy - 4y^2 - 6x + 4y + 9 = 0$ to the standard form. Find also the equations of the latus rectum, axes and the directrices. (20)

- (b) Show that the locus of the middle points of all normal chords of the hyperbola $x^2 - y^2 = a^2$ is given by $(y^2 - x^2)^3 = 4a^2x^2y^2$. (15)