

Shubhra Kanti
31/12/12

L-2/T-1/IPE

Date : 31/12/2012

BANGLADESH UNIVERSITY OF ENGINEERING AND TECHNOLOGY, DHAKA

L-2/T-1 B. Sc. Engineering Examinations 2011-2012

Sub : **CSE 295** (Computer Programming Techniques)

Full Marks : 210

Time : 3 Hours

The figures in the margin indicate full marks.

USE SEPARATE SCRIPTS FOR EACH SECTION

SECTION – A

There are **FOUR** questions in this section. Answer any **THREE**.

1. (a) Define a structure data type *player_info* for storing information of football players. You need to store each player's *name* (maximum 20 characters) and *country* (maximum 20 characters), *the name of the team* (maximum 20 characters) the player is playing for, and the *number of years* the player is playing for the team. You can assume that each player's name will consist of one word only. (6)
- (b) (i) Declare an array of *player_info* type as is defined in Q. 1(a). The array will be used to store information of **ten** players. (3+6+7=16)
- (ii) Write appropriate C codes in main function to take information of ten players as input from the user and store them in the array. Use *scanf* function for input.
- (iii) Declare a pointer of type *player_info*. Show how we can use this pointer to print the information of the ten players stored in the array. Use pointer expression for this purpose.
- (c) Write a function *sort_player(...)*. The function will be used to sort players' array as defined in Q. 1(a) and Q. 1(b). The data will be sorted according to the names of players in lexicographical order. The function will have two arguments: an array of *player-info* type and number of players to sort (an integer value). (13)
2. (a) Write a computer program that takes a *filename* as input from a user. The program will create a copy of the file. Your program must use *fgetc* and *fputc* functions to read/write from files. You can use any name for the output file. (11)
- (b) Write a program that takes a *filename* as input from a user. The program will count the number of words in the file and output this number in another file. You can use any name for the output file. You can assume that the input file contains only letters, digits, and spaces. Words consist of letters and digits, and successive words are separated by spaces. (12)
- (c) Briefly describe the following library functions stating their input arguments and return values: (12)

(i) *fread* (ii) *fwrite* (iii) *feof*

Contd P/2

14

CSE 295

3. (a) Write a program that will take *a number of integers* as input from a user. The program will find the median and mode of those numbers. To find the median, the numbers have to be listed in numerically sorted order. Then the middle element is the median. For example, if the list is {4, 1, 1, 10, 3, 5, 7}, then after sorting in ascending order, we find the list as {1, 1, 3, 4, 5, 7, 10}. The median will be the 4-th element, which is 4. Note that, if the number of elements in the list is even, then the average of two middle elements will be the median. (20)

The mode is the number that is repeated more often than any other, so in the above list 1 is the mode. If there is no such number which appears maximum times, your program should print "No Mode".

Sample input: {4, 1, 1, 10, 3, 5, 7} sample output: median=4, mode=1

Sample input: {2, 1, 4, 7} sample output: median=3, mode=No Mode.

(b) What is meant by EOF? (3)

(c) Write a recursive function that can be used to print the characters of a string in reversed order. (12)

4. (a) Draw a flowchart for computing the factorial of *N*, where *N* is the input variable from a user. (13)

(b) Briefly describe the following storage classes: (9)

- (i) *automatic*
- (ii) *static*
- (iii) *extern*

(c) What is the difference between compile errors and run-time errors? Explain with examples. (5)

(d) Briefly explain three debugging tools/techniques. (8)

SECTION - B

There are **FOUR** questions in this section. Answer any **THREE**.

5. (a) Write the differences between signed and unsigned data types. Can these qualifiers be applied to double or float? (5)

(b) Which number system is used in a computer system and why? (5)

(c) Write a program to print the following multiplication table in the following format. (10)

	1	2	3	4	5
1	1	2	3	4	5
2	2	4	6	8	10
3	3	6	9	12	15
4	4	8	12	16	20
5	5	10	15	20	25

(d) Explain bitwise right shift operator. Write a program that takes an integer, *x*, as input and outputs the number of 1s in its binary representation. (5+10)

CSE 295

6. (a) Write short notes on local, global and static variables. What are the features of static local and static global variables? (6+4)

(b) Explain the output of the following program? (5)

```
# include<stdio.h>
int main ( )
{
    int a=2, b=7, c=10;
    c=a= b;
    printf ("%d", c);
    return 0;
}
```

(c) Write a program that obtains the sum of the first n-terms of the following series: (15)

$1 + (2 + 3*4) + (5 + 6*7 + 8*9*10) + \dots$ upto nth term

(d) What will be the output of the following arithmetic expression? (5)

$5+3*2\%10-8*6$

7. (a) Consider the following code: (5)

```
int testarray [3] [2] [2] = {1, 2, 3, 4, 5, 6, 7, 8, 9, 10, 11, 12};
```

What value does testarray [2][1][0] in the sample code above contain?

(b) What is the difference between the definition and the declaration of a variable? (5)

(c) Perfect number is a positive integer that is equal to the sum of its proper divisors. The smallest perfect number is 6, which is the sum of 1, 2 and 3. Other perfect numbers are 28, 496, and 8128. Write a program to check whether the given number is a perfect number or not. (15)

(d) Write a program to convert all the upper case letters to lower case and lower case letters to upper case in a given string. (10)

8. (a) When should we use ternary operator? Show an example. (5)

(b) Write a program to find the second largest element in an array without sorting the array. (10)

(c) Write a program that takes two matrices of different or same order from user and find the product of these matrices and then prints the product matrix. You must also check the condition that the column of the first matrix must be equal to the row of the second matrix. (20)

BANGLADESH UNIVERSITY OF ENGINEERING AND TECHNOLOGY, DHAKA

L-2/T-1 B. Sc. Engineering Examinations 2011-2012

Sub : **EEE 271** (Electrical Machines and Electronics)

Full Marks : 210

Time : 3 Hours

The figures in the margin indicate full marks.

All the symbols have their usual meanings.

USE SEPARATE SCRIPTS FOR EACH SECTION

SECTION - AThere are **FOUR** questions in this section. Answer any **THREE**.

1. (a) A 50 KVA, 2400 V/600 V, 60 Hz transformer is tested for determining the equivalent circuit parameters. The following test data are obtained: (25)

Open Circuit Test (Low voltage Side)	Short Circuit Test (High voltage Side)
$V_{OC} = 600 \text{ V}$	$V_{SC} = 76.4 \text{ V}$
$I_{OC} = 3.34 \text{ A}$	$I_{SC} = 20.8 \text{ A}$
$P_{OC} = 484 \text{ W}$	$P_{SC} = 754 \text{ W}$

(i) Find the equivalent circuit referred to the high voltage side.

(ii) Find the voltage regulation and efficiency at rated load and 0.92 power factor lagging.

- (b) Develop an approximate equivalent circuit of a transformer referred to the secondary side. (10)

2. (a) Derive the expression of induced torque for a typical three phase induction motor. Show that the pullout torque occurs at a slip of (17)

$$s_{\max} = \frac{R_2}{\sqrt{R_{TH}^2 + (X_{TH} + X_2)^2}}$$

- (b) A 480 V, 50 Hz, 25 hp, 4 pole, Y connected induction motor has the following parameters: (18)

$R_1 = 1 \Omega$

$R_2 = 0.5 \Omega$

$X_1 = 1 \Omega$

$X_2 = 0.5 \Omega$

$X_M = 50 \Omega$

Total rotational losses are always 800 W. For a rotor slip of 3%, find the

(i) Stator current

(ii) Air-gap power

Contd P/2

EEE 271

3. (a) Explain the effect of load changing on a synchronous motor using phasor diagram. (15)

(b) An infinite bus operates at a line voltage of 800 V. Three motors are connected to the bus in parallel: (10+10)

	Model-1 3φ	Model-2 3φ	Model-3 3φ
Motor Type	Induction Motor	Induction Motor	Synchronous Motor
Input power	300 kW	300 kW	300 kW
Power factor	0.75 lagging	0.7 lagging	0.8 lagging

- (i) Find the total transmission line current
- (ii) Find the power factor of Motor-3 so that the transmission line current is reduced by 20%

4. (a) In case of a DC motor, prove that (10)

$$\tau_{ind} = K\phi I_A$$

(b) Explain the effect of armature resistance speed control method on the torque speed characteristics of a DC shunt motor by drawing an appropriate curve. (10)

(c) A 150 hp, 250 V cumulatively compounded (with long shunt configuration) DC motor without compensating winding has armature resistance of 0.03 Ω and the series winding resistance of 0.01 Ω. The shunt field and the series field have 1000 turns and 3 turns per pole, respectively. The no load speed is 1200 rpm. The magnetization curve is shown in Fig. for Q. 4(c). Find the speed of the motor when armature current is 200 A and armature reaction is 100 A-turns. (15)

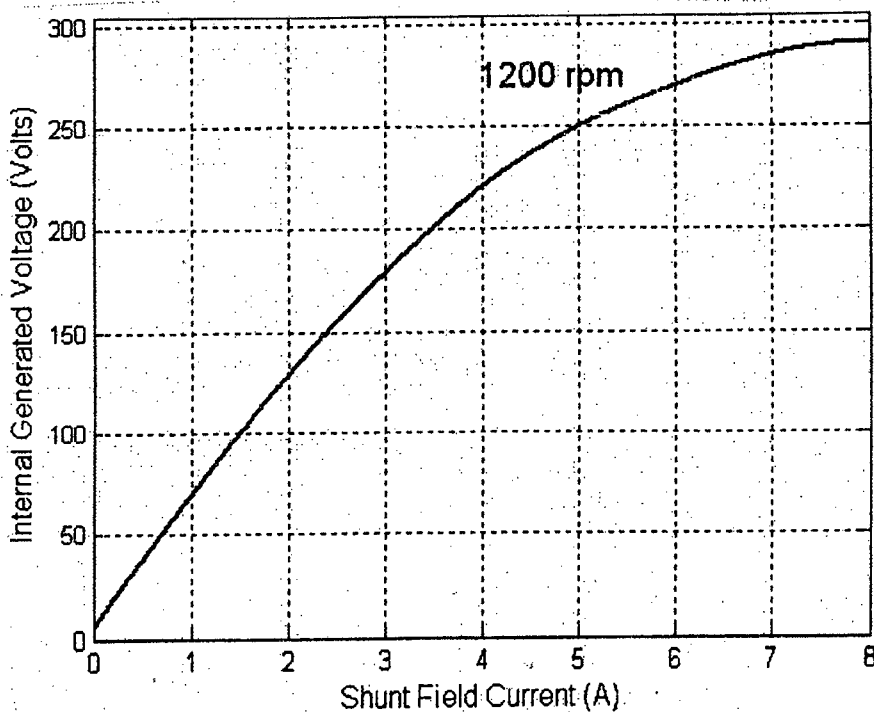

Figure for Q 4(c)

EEE 271

SECTION - B

There are **FOUR** questions in this section. Answer any **THREE**.

5. (a) Derive the expression of the V_{out} for the circuit shown in Fig. 5(a). (15)

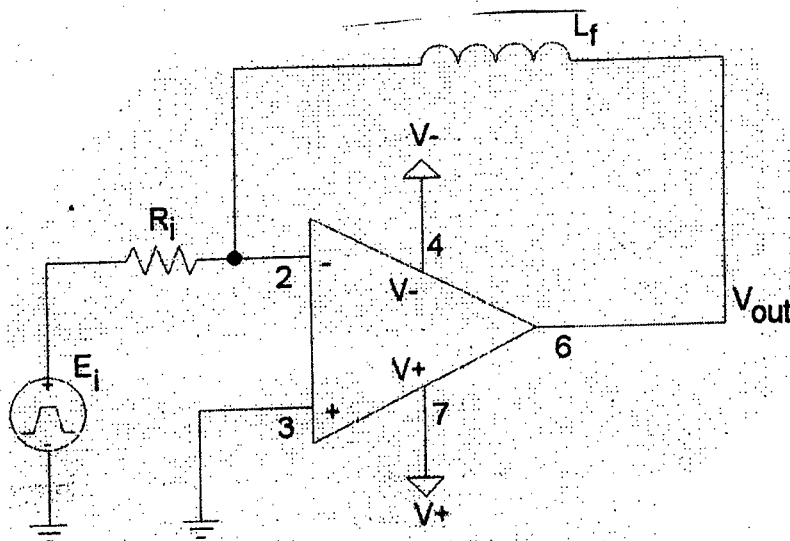
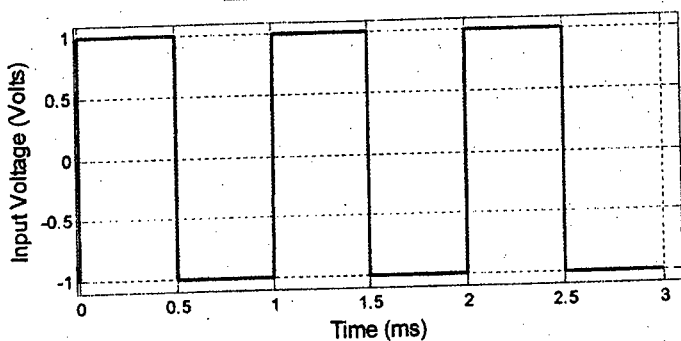
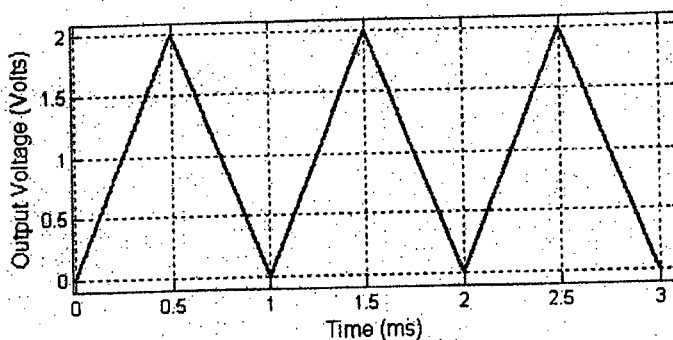

Figure for Q5(a)

- (b) Design an OP-Amp circuit that produces the output waveshape shown in Fig. 5(b) for the input waveshape given in the same figure. (20)



Input waveshape



Output waveshape

Figure for Q 5(b)

EEE 271

6. (a) Design an OP-Amp circuit so that it provides the output, $V_{out} = 5 v_1 + 10 \frac{dv_2}{dt}$,

where v_1 and v_2 are the inputs. (10)

(b) If the resistivity of the strain gauge material is not changed by strain, prove that $G_f = 1 + 2\nu$, where G_f is the gauge factor and ν is the Poisson's ratio. (15)

(c) Find the output of the circuit shown in Fig. 6(c) if the input offset voltage is 100 mV and the input bias currents are negligible. (10)

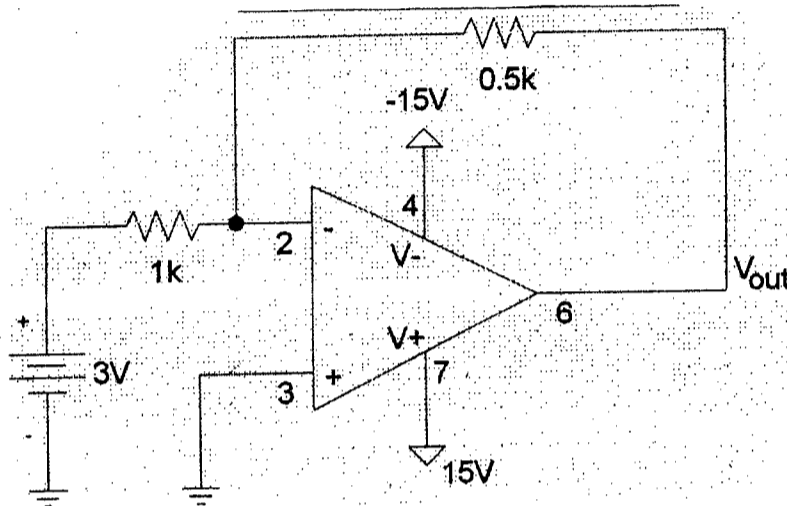

Figure for Q. 6(c)

7. (a) Derive the expression of sensitivity of capacitive transducer in a differential arrangement for measuring displacement. (15)

(b) In a differential arrangement of capacitive transducer, 5 V is applied between fixed plate-1 and fixed plate-2. If the movable plate moves 3 mm towards fixed plate-1 from the mid-position, the differential voltage is found to be 0.15 V. (10)

(i) If the displacement of the movable plate is 10 mm towards fixed plate-1, find the voltage between fixed plate-1 and the movable plate.

(ii) Find the sensitivity

(c) Positive longitudinal strain is applied to a strain gauge with circular cross-section increasing the length by 1 mm. The unstrained length was 2 m. If the strain changes the resistance by 0.01% and the resistivity remains unchanged, find the lateral strain. (10)

8. (a) Explain the operation of AC phase control circuit for a DC load using SCR. Sketch the waveshapes across the capacitor, SCR and the load. (20)

(b) Derive the torque-speed characteristics of a shunt DC motor and draw a typical curve for this type of motor. (15)

SECTION – A

There are **FOUR** questions in this section. Answer any **THREE**.

1. (a) What is Perovskite structure? Explain how dielectric behaviour of BaTiO_3 changes as temperature decreases below curie temperature. (9)
- (b) Differentiate among ferromagnetism, ferrimagnetism, diamagnetism and anti-ferromagnetism. (8)
- (c) Water present in formed ceramic body can be divided into four parts – explain in brief. (6 1/3)

2. (a) What is meant by sintering process? Discuss the factors those influence sintering. (8)
- (b) Graphically show the difference between acceptable and marginal/unacceptable reliability in reliability test data. (5 1/3)
- (c) A series of square section bars are tested in 3-point bend test. Determine (10)
 - (i) Weibull modulus, m
 - (ii) Median strength, S_m (for which $P_f = 0.5$), and
 - (iii) Normalised stress (S_0) of the ceramic.

The failure strength (MOR) data: 178, 318, 345, 210, 296, 235, 248, 276, 262

3. (a) It is not only the chemical formula which determines the crystal structure but also the relative sizes of the cations and anions – explain with example. (10)
- (b) Draw a neat sketch of a FCC structure showing tetrahedral and octahedral positions. (5 1/3)
- (c) Describe different types of defects in ceramic structures. (8)

4. (a) What is mesh size? Among jaw crusher, runner crusher and ball mill, which one will produce fragmented particle of maximum mesh size? (5 1/3)
- (b) Describe uniaxial pressing method with a neat sketch. (8)
- (c) Why do ceramics exhibit higher yield strength than metals whether it is covalent or ionic ceramic – explain. (10)

MME 295 (IPE)

SECTION – B

There are **FOUR** questions in this section. Answer any **THREE**.

5. (a) Describe schematically the mechanism of hardening of Portland cement. (14 1/3)
(b) Write short notes on concrete and high alumina cement. (9)
6. (a) A continuous and aligned glass fibre-reinforced composite consists of 40 Vol.% glass fibres having a modulus of elasticity of 69 GPa and 60 Vol.% polyester resin that when hardened, displays a modulus of elasticity of 3.4 GPa. (14 1/3)
(i) Compute the modulus of elasticity of the composite in the longitudinal direction.
(ii) If the cross-sectional area is 250 mm² and a stress of 50 MPa is applied in the longitudinal direction, compute the magnitude of the load carried by each of the fibre and matrix phases.
(iii) Determine the strain that is sustained by each phase when stress of 50 MPa is applied.
(b) For a polymer-matrix fiber-reinforced composite, compare the desired mechanical characteristics of matrix and fiber phases. (4 1/2)
(c) Explain how composite stiffness varies with fibre orientation. (4 1/2)
7. (a) Define glass. What are the basic requirements for glass forming? (5 1/3)
(b) Describe press and blow technique for producing a glass bottle. (6)
(c) Glass reinforcement is possible in several ways – explain in detail. (12)
8. (a) Describe the common types of polymer molecular structures. (6)
(b) Explain two types of polymerization reactions with examples. (10)
(c) Explain the differences between melting and glass transition temperature. (7 1/3)
-

SECTION - AThere are **FOUR** questions in this section. Answer any **THREE**.

1. Solve the following differential equations:

(a) $(2x + y + 3) \frac{dy}{dx} = x + 2y + 3$ (14)

(b) $y(x^2y^2 + 2) dx + x(2 - 2x^2y^2) dy = 0$ (10)

(c) $(1 - x^2) \frac{dy}{dx} - xy = xy^2$ (11)

2. Find the general solution of the following higher order differential equations:

(a) $\frac{d^2y}{dx^2} - 6 \frac{dy}{dx} + 13y = 8e^{3x} \sin 2x$ (11)

(b) $\frac{d^3y}{dx^3} + 2 \frac{d^2y}{dx^2} - 3 \frac{dy}{dx} = x^2 + 2 \sin x$ (12)

(c) $x^2 \frac{d^2y}{dx^2} - x \frac{dy}{dx} + 4y = x^2 \sin(\log x)$ (12)

3. (a) Using Fröbenius method obtain a general solution in series in powers of x of the equation (28)

$$2x^2 \frac{d^2y}{dx^2} - x \frac{dy}{dx} + (x - 5)y = 0.$$

(b) Prove that $xJ'_n(x) = xJ_{n-1}(x) - nJ_n(x)$. (7)

4. (a) Prove that $P_n(x) = \frac{1}{2^n n!} \frac{d^n}{dx^n} (x^2 - 1)^n$. (15)

(b) Show that $\frac{d}{dx} \{x J_n(x) J_{n+1}(x)\} = x \{J_n^2(x) - J_{n+1}^2(x)\}$. (10)

(c) Prove that $\int_{-1}^1 x P_n(x) P_{n-1}(x) dx = \frac{2n}{4n^2 - 1}$. (10)

Contd P/2

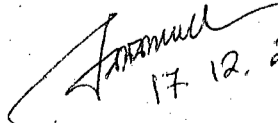
 17.12.2012

MATH 291**SECTION - B**There are **FOUR** questions in this section. Answer any **THREE**.

5. (a) If $\underline{r} = \cos nt \hat{i} + \sin nt \hat{j}$, where n is a constant and t is a variable, find $\underline{r} \times \left(\frac{d\underline{r}}{dt} \right)$. (8)

(b) Find the equations of the tangent line and the normal plane to the curve $x^2 + 2y^2 + 3z^2 = 1$, $x + y + z = 1$ at $(1, 0, 0)$. (11)

(c) What is the greatest rate of increase of $u = xyz^2$ at the point $(1, 0, 3)$. (11)

(d) Give the physical significance of the curl of a vector point function. (5)

6. (a) Evaluate $\iint_S \underline{A} \cdot \hat{n} \, dS$, where $\underline{A} = y\hat{i} + 2x\hat{j} - z\hat{k}$ and S is the surface of the plane $2x + y = 6$ in the first octant cut off by the plane $z = 4$. (17)

(b) Verify Green's theorem in the plane for $\oint_C [(3x^2 - 8y^2)dx + (4y - 6xy)dy]$ where C is the region bounded by the parabolas $y^2 = x$ and $y = x^2$. (18)

7. (a) Find the Laplace transform of sine integral function. (10)

(b) Find $L \left\{ \frac{2}{\sqrt{\pi}} \int_0^{\sqrt{t}} e^{-u^2} du \right\}$. (10)

(c) Evaluate the integrals:

(i) $\int_0^{\infty} t e^{-2t} \cos t \, dt$ (8)

(ii) $\int_0^{\infty} \frac{e^{-t} - e^{-3t}}{t} \, dt$ (7)

8. Find the following:

(a) $L^{-1} \left\{ \log \frac{s+b}{s+a} \right\}$ (10)

(b) $L^{-1} \left\{ \frac{3s+1}{(s-1)(s^2+1)} \right\}$ (13)

(c) Using Laplace transform solve : $tY''(t) + 2Y'(t) + tY(t) = 0$, where $Y(0) = 1$, $Y'(0) = c$. (12)

Sushanta
14/11/13

L-2/T-1/IPE

Date : 19/11/2012

BANGLADESH UNIVERSITY OF ENGINEERING AND TECHNOLOGY, DHAKA

L-2/T-1 B. Sc. Engineering Examinations 2011-2012

Sub : **ME 245** (Engineering Mechanics and Theory of Machines)

Full Marks: 280

Time : 3 Hours

USE SEPARATE SCRIPTS FOR EACH SECTION

The figures in the margin indicate full marks.

SECTION – A

There are **FOUR** questions in this Section. Answer any **THREE**.

1. (a) The angular velocity of the crank OA is 600 rpm as shown in Fig. for Q. 1(a). Determine the linear velocity of the slider D and the angular velocity of the link BD, when the crank is inclined at an angle of 75° to the vertical. The dimensions of various links are: OA = 28 mm; AB = 44 mm; BC = 49 mm; and BD = 46 mm. The distance between the centres of rotation O and C is 65 mm. The path of travel of the slider is 11 mm below the fixed point C. The slider moves along a horizontal path and OC is vertical. (28 $\frac{2}{3}$)
(b) A pulley is driven by a flat belt, the angle of lap being 130° . The belt is 100 mm wide by 5 mm thick and density 1200 kg/m^3 . If the coefficient of friction is 0.3 and the maximum stress in the belt is not to exceed 2.5 MPa, find the greatest power which the belt can transmit and the corresponding speed of the belt. (18)
2. A cam, with a minimum radius of 25 mm, rotating clockwise at a uniform speed is to be designed to give a roller follower at the end of a valve rod, a motion described below: (46 $\frac{2}{3}$)
(i) To raise the valve through 45 mm during 120° rotation of the cam; (ii) To keep the valve fully raised through next 60° ; (iii) To lower the valve during next 90° ; and (iv) To keep the valve closed during rest of the revolution;
The diameter of the roller is 20 mm and the diameter of the cam shaft is 25 mm.
Draw the profile of the cam when the line of the stroke is offset 15 mm from the axis of the cam shaft. The displacement of the valve, while being raised and lowered, is to take place with simple harmonic motion.
3. (a) State and prove the law of gearing. (20)
(b) In an epicyclic gear of the 'sun and planet' type shown in Fig. for Q. 3(b), the pitch circle diameter of the internally toothed ring is to be 280 mm and the module 5 mm. When the ring D is stationary, the spider A, which carries three planet wheels C of equal size, is to make one revolution in the same sense as the sunwheel B for every five revolutions of the driving spindle carrying the sunwheel B. Determine suitable numbers of teeth for all the wheels. (26 $\frac{2}{3}$)

Contd P/2

ME 245

4. (a) Derive the differential equation characterizing the motion of an oscillation system subject to viscous damping and no periodic external force. Assuming the solution to the equation, explain the terms 'under damping' and show that the frequency of oscillation

of the system is $f_d = \frac{1}{2\pi} \sqrt{\frac{s}{m} - \left(\frac{c}{2m}\right)^2}$, where symbols have their usual meanings. (26%)

- (b) A machine of mass 80 kg is mounted on springs and is fitted with a dashpot to damp out vibrations. There are three springs each of stiffness 15 N/mm and it is found that the amplitude of vibration diminishes from 42 mm to 8 mm in two complete oscillations. Assuming that the damping force varies as the velocity, determine: (i) the resistance of the dashpot at unit velocity; (ii) the ratio of the frequency of the damped vibration to the frequency of the undamped vibration; and (iii) the periodic time of the damped vibration. (20)

SECTION - B

There are **FOUR** questions in this Section. Answer any **THREE**.

5. (a) Find the magnitude and direction of the resultant of the two non-coplanar forces shown in Fig. 5(a). (16%)

- (b) Determine the forces in every member of the truss in Fig. 5(b). Each horizontal member is 3.6 m long and each inclined member is 3 m long. (30)

6. (a) Determine the speed of block A in Fig. 6(a) while the speed of block B is 2 m/s in upward direction. (20)

- (b) Determine the mass moment of inertia of a right circular cone with respect to its longitudinal axis and an axis, perpendicular to the longitudinal axis, through the vertex of the cone. (26%)

7. (a) The cylinder in Fig. 7(a) has weight W and radius 'r'. Express the magnitude of the largest couple M in terms of W and r which can be applied to the cylinder before it starts rotating. Assume that the coefficient of static friction is 0.3 at A and 0.36 at B. (26%)

- (b) Determine the centroid of the parabolic section in Fig. 7(b) where OA is a straight line and A(x,y) is A(240 mm, 150 mm). (20)

8. (a) The motion of a 1.8 kg block A in a horizontal plane, shown in Fig. 8(a), defined by the relations $r = 3t^2 - t^3$ and $\theta = 2t^2$, where r is expressed in meter, t in seconds and θ in radians. Find the radial and transverse components of the force exerted on the block when (i) $t = 0$ sec and (ii) $t = 1$ sec. (23%)

- (b) A 10 kg block rests on the horizontal surface as shown in Fig. 8(b). The spring, which is not attached to the block, has a stiffness of $k = 500$ N/m and is initially compressed 0.3 m from C to A. After the block is released from rest at A, determine the distance it passes from A before come to rest. The coefficient of kinetic friction between the block and the plane is 0.2. (20)

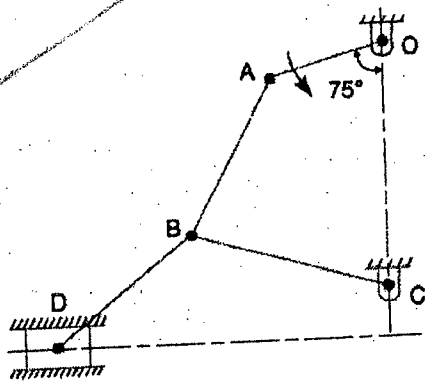

Fig. for Q. 1(a)

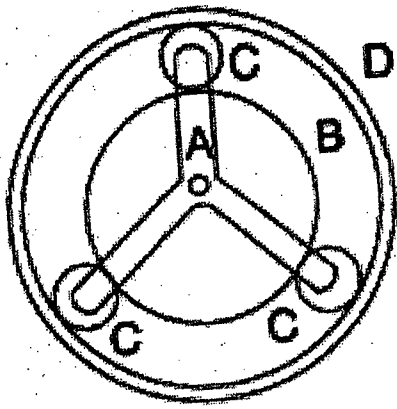

Fig. for Q. 3(b)

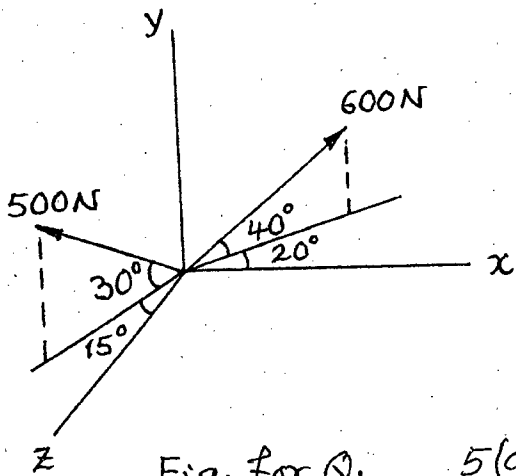

Fig. for Q. 5(a)

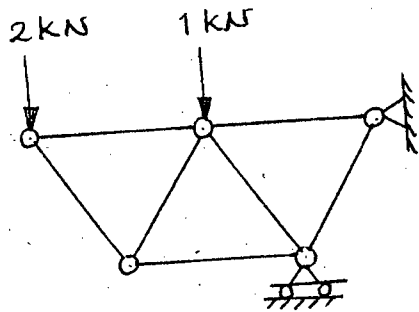

Fig. for Q. 5(b)

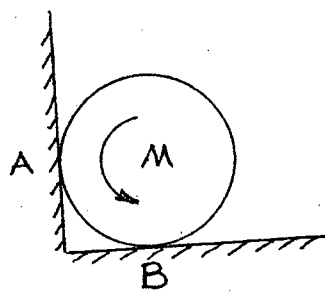

Fig. for Q. 7(a)

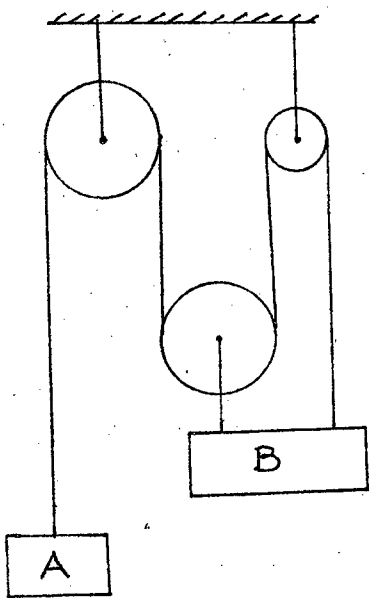

Fig. for Q. 6(a)

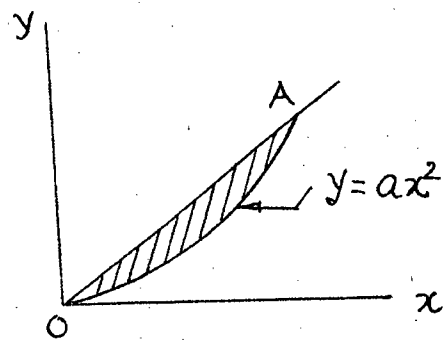

Fig. for Q. 7(b)

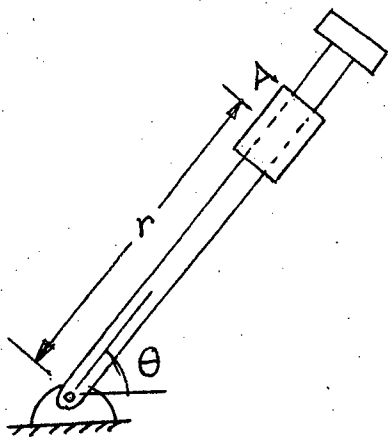

Fig. for Q. 8(a)

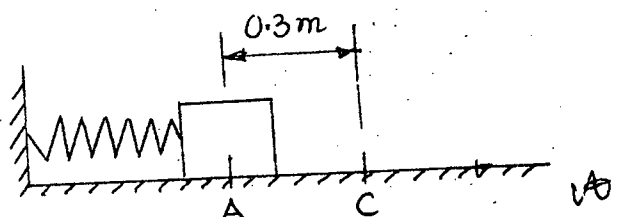

Fig. for Q. 8(b)