

**SECTION - A**

There are **FOUR** questions in this section. Answer any **THREE**.

1. (a) Define "Optimistic time estimate", "Pessimistic time estimate" and "Most likely time estimate". The time estimates for three activities A, B and C are as follows: (11)

	Optimistic Time	Most Likely time	Pessimistic time
A	10	12	14
B	6	8	12
C	5	10	12

Determine expected time and variance for each activity which activity has more reliable time estimates?

- (b) List 5 civil engineering construction equipment and mentioned their functions. (7)
- (c) Explain "2-stage tendering" process. What do you mean by "Pre-Qualification" in a tendering process? Explain the tendering procedure. (10)
- (d) List the information required for Resource Scheduling Method (RSM). Briefly explain the theory of RSM. (7)
2. (a) Explain the ability to influence construction cost overtime, why safety is a prime requisite in construction site? List the causes of total accidents in construction industry. (10)
- (b) What safety measures are required for hot bituminous construction work? Explain "Quality control ensure that the work proceeds in accordance with the specifications, and inspection is the tool through which quality control is exercised". (10)
- (c) A transport company has two types of trucks, Type A and Type B. Type A has a refrigerated capacity of  $20 \text{ m}^3$  and a non-refrigerated capacity of  $40 \text{ m}^3$ , while type B has the same overall volume with equal sections for refrigerated and non-refrigerated stock. A grocer needs to hire trucks for the transport of  $3000 \text{ m}^3$  of refrigerated stock and  $4000 \text{ m}^3$  of non-refrigerated stock. The cost per km of a type A is USD 30 and USD 40 for type B. How many trucks of each type should the grocer rent to achieve the minimum total cost (Use LP model)? (15)

20

Contd ..... P/2

20

**CE 401**

3. (a) A construction project consists of 16 activities represented by the network shown in Figure 1. The duration required to perform various activities of the project are given in the figure 1. Compute (i) event time (ii) Activity time (EST, EFT, LST, LFT) (iii) total float. Also determine critical path/paths. (23)

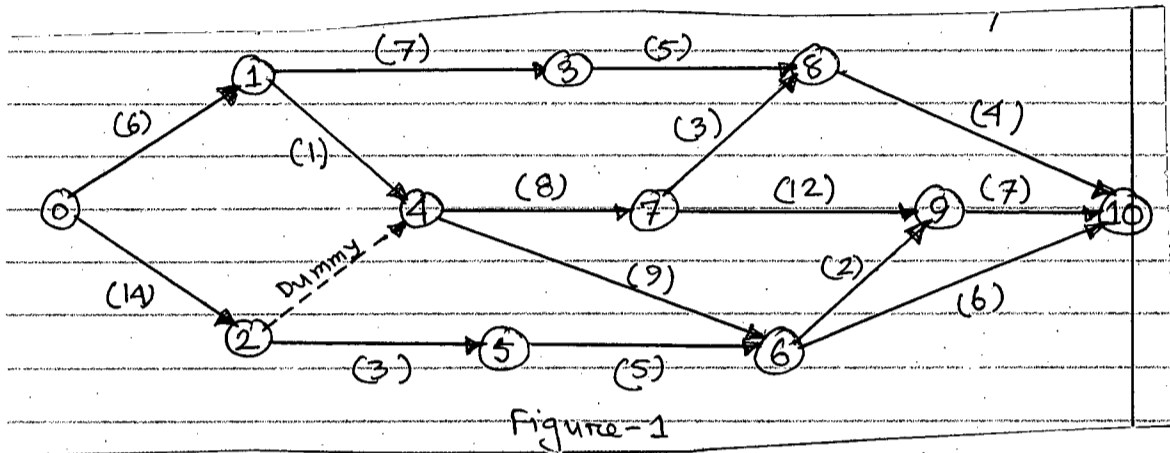

- (b) A typical small house construction project consists of the following operations along with the time set for its completion. Draw the Bar chart. (12)

<u>Activity</u>	<u>Duration (weeks)</u>
• Preparation of structural drawing	5
• Survey and site selection	4
• Tendering	4
• Award of work order	1
• Preparation of specification and tender documents	3
• Selection of contractor	2

What is a milestone chart? How does it differ from a bar chart.

4. (a) A project consists of eight activities M, N, O, P, Q, R, S and T. Draw the networked and number the events if: (9)

- Activities M, N and Q can start concurrently.
- Activities O and P are concurrent and depend on the completion of both M and N.
- Activities R and S are concurrent and depend on the completion of O.
- Activity T depends upon the completion of P, Q and R.
- The project is complete when S and T are done.

**CE 401**

**Contd ... Q. No. 4**

(b) For the network shown in Figure 2, the time estimates (in days) for each activity are mentioned. Determine the expected time for each path. Which path is critical? (8)

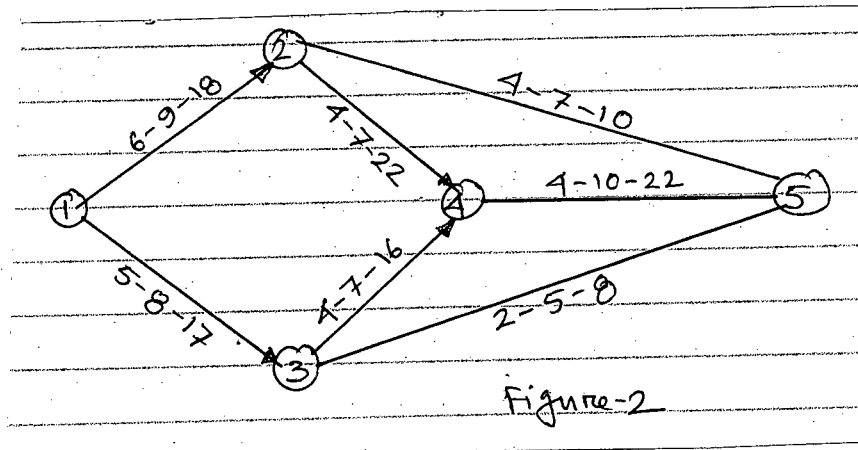

(c) Describe "Project management cycle". Differentiate between Probabilistic approach and Deterministic approach. (9)

(d) List the steps of Development of a network diagram. Differentiate Activity oriented diagram and Event Oriented diagram. (9)

**SECTION - B**

There are **FOUR** questions in this section. Answer any **THREE**.

Assume missing data if any.

5. (a) What is a project? Explain the natural sequence of a project life cycle and various aspects of project preparation. Discuss the purpose and perspectives of a feasibility study and give an overview of various components of a typical feasibility report. (22)

(b) Define the terms "organisation" and "management" and state different approaches and theories of management development. List some fundamental principles of management organisation. (13)

6. (a) Discuss the significance and emerging role of management education and leadership functions in Civil Engineering Practices. State the concepts, framework and principles of motivation. Explain the process of leading, directing and guiding. (17)

(b) State the advantages and disadvantages of line organisation and explain with a suitable diagram a line and staff organisation. List the factors which should be taken into consideration in the following: (18)

- (i) Decentralisation
- (ii) Span of control

**CE 401**

7. (a) Classify human needs. Briefly discuss the following:

(20)

- (i) Controlling conflicts in Management
- (ii) Delegation and Authority Relationship
- (iii) Matching Jobs and Individuals

(b) What is a "Sensitivity Analysis"? Assume that you wish to make an economic comparison of two alternative projects which have different economic lives – one 15 years and the other 20 years. What special steps should you take in the analysis if you wish to compare the projects on a net present value basis? What would be a simpler way of comparing the projects?

(15)

The Agricultural Development Bank lends to framers at 12 percent interest to finance tubewells. If a farmer borrows Tk 25,000/- for a tubewell to be repaid in 10 years, what is the annual amount of his combined interest and principal payment?

8. (a) Explain with an example the fundamental difference between economic and financial analysis of a project. List and explain the most commonly used criteria/measures for the economic appraisal of projects and which method is regarded as the best one and why?

(13)

(b) Explain the meaning and significance of Capital Recovery Factor (CRF) and Sinking Fund Factor (SFF). Using NPV method, select the best alternative from the Table below.

Assume discount rate of 12 percent per annum.

(22)

	Alternative A	Alternative A
Initial Cost	\$ 110,000	\$ 70,000
Net income/year	\$ 22,000	\$ 11,000
Salvage Value	\$ 6,000	\$ 0,000
Expected Life	10 years	10 years

-----

**SECTION - A**

There are **FOUR** questions in this Section. Answer any **THREE**.

1. (a) For the plane frame of Fig. 1, determine the ordinates of influence line for reaction at support D. Evaluate the ordinates at locations 1 and 2 as indicated. Assume E (Young's modulus) constant. (23 1/3)

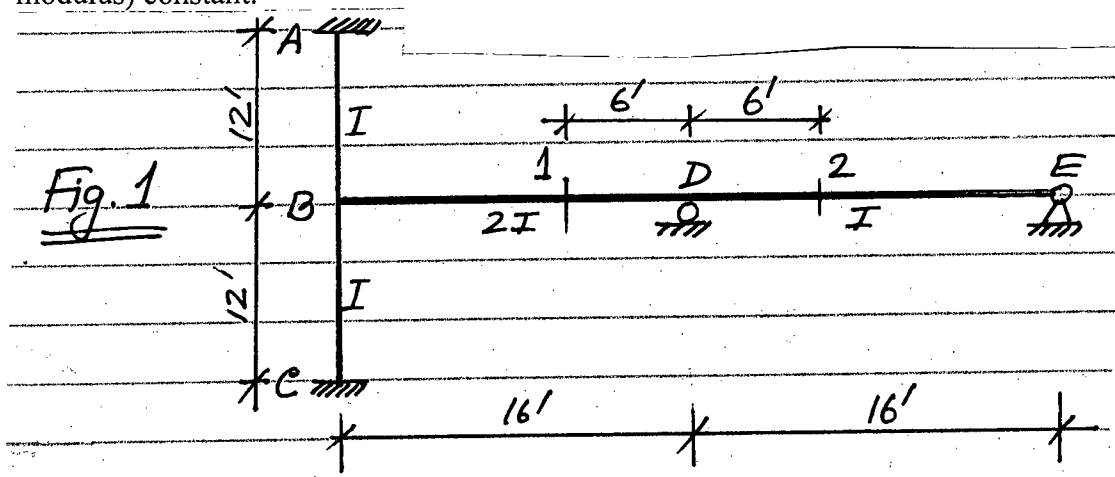

- (b) Analyze the beam of Fig. 2 using moment distribution method and draw the shear force and bending moment diagrams. (23 1/3)

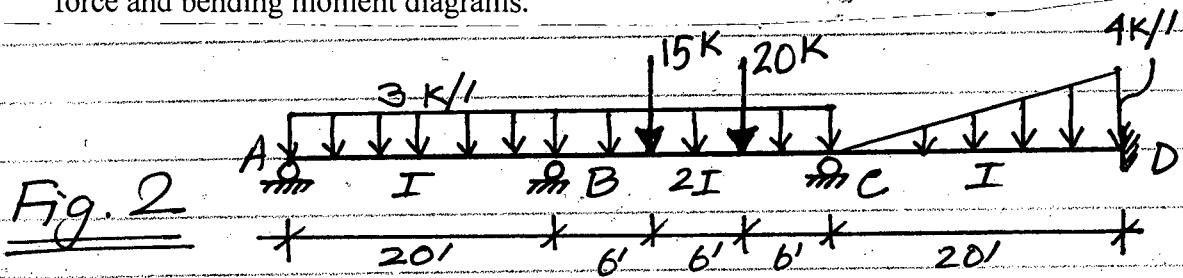

2. (a) The frame of Fig. 3 is acted upon by the forces as shown. In addition to that, the support at A rotates 0.025 radian in clockwise direction as well as moves 0.15' to the right. Analyze the frame using slope-deflection method and determine the horizontal sway at point C. For this frame, take  $EI = 4000 \text{ k-ft}^2$ . (23 1/3)

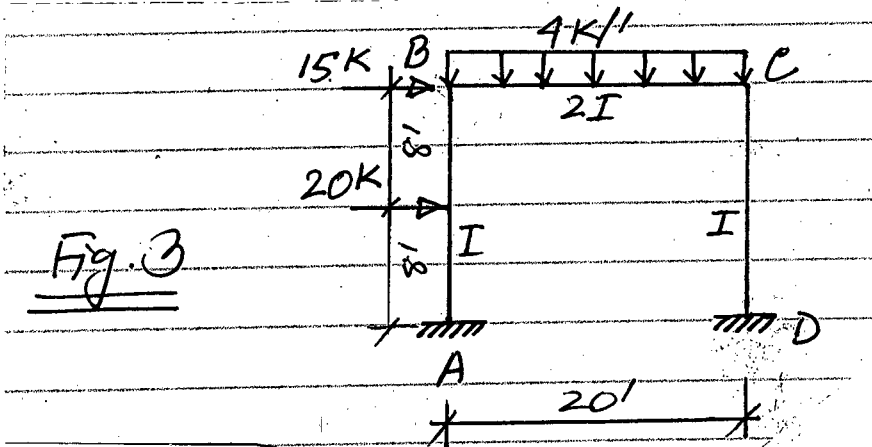

**CE 411**

**Contd ... Q. No. 2**

(b) Analyze the frame of Fig. 4 using moment distribution method and determine the moment developed at support E.

(23 1/3)

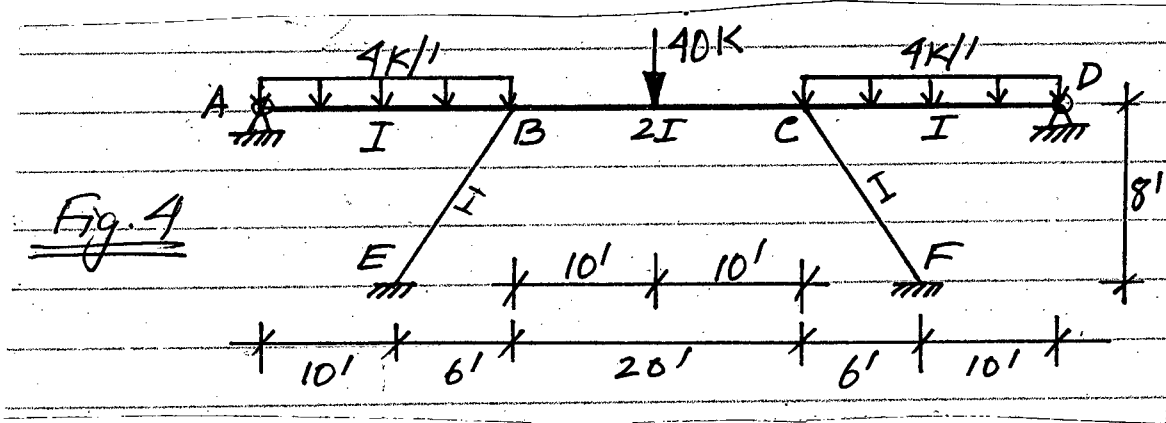

3. (a) Analyze the frame of Fig. 5 using moment distribution method and determine the horizontal deflection at point C. Take  $EI = 3000 \text{ k-ft}^2$  for this frame.

(23 1/3)

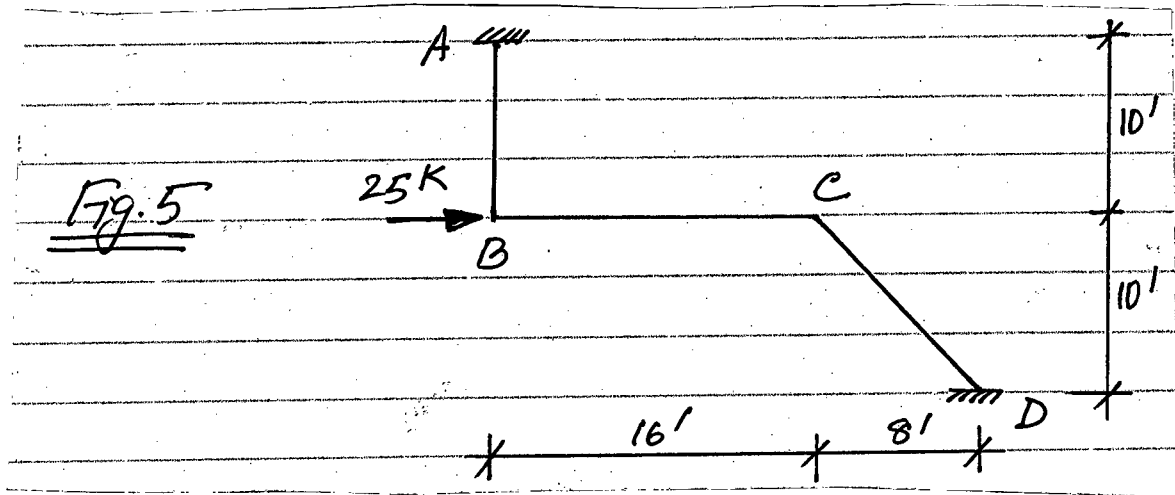

(b) For the frame of Fig. 6, determine the ordinates of influence line for the shear at location E as indicated. Evaluate the ordinates at locations 1 and 2 as indicated.

(23 1/3)

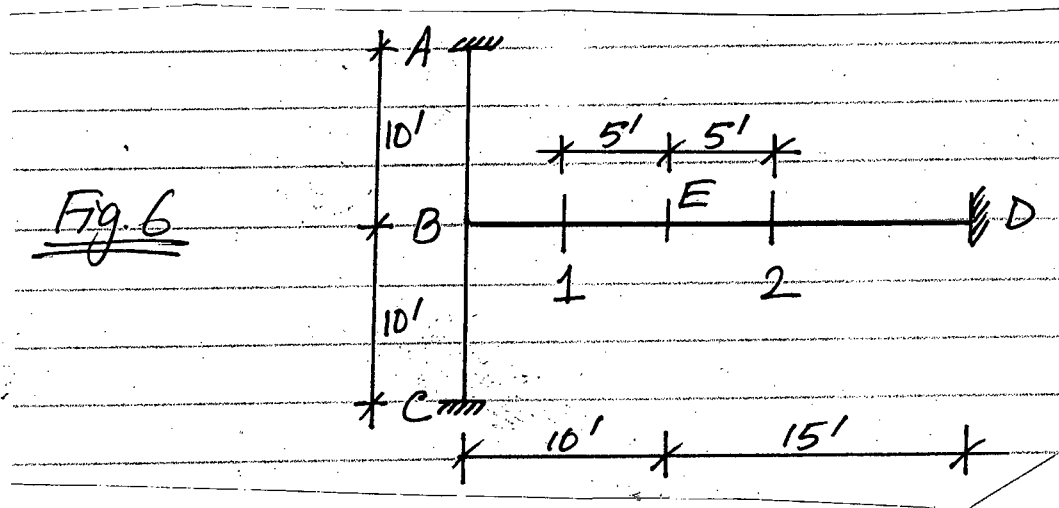

**CE 411**

4. (a) In addition to the loads acting on the beam of Fig. 7 as shown, the support at A rotates 0.04 radian clockwise while the support at C settles down 0.2 ft. Analyze the beam using moment distribution method and determine the reaction at support B. (23 1/3)

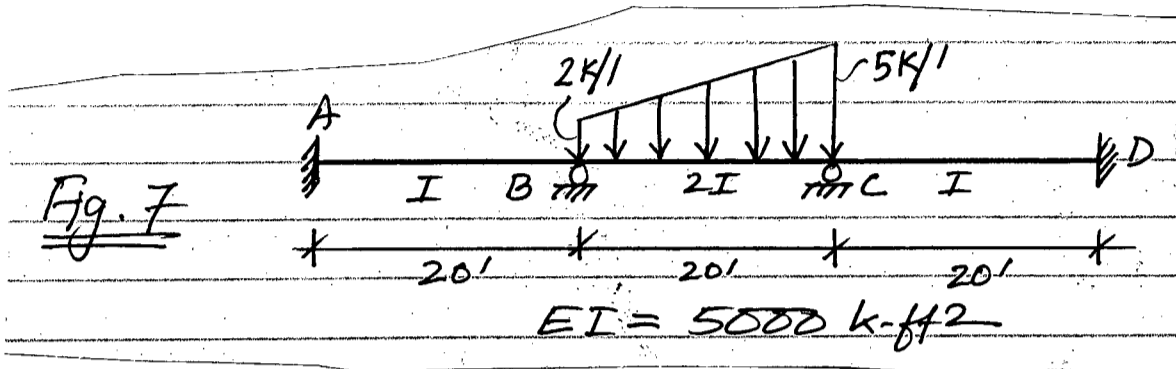

- (b) (i) Derive the Muller-Breslau's principle of drawing influence lines. (12)  
 (ii) Derive the slope-deflection equations of a beam element. (11 1/3)

**SECTION - B**

There are **FOUR** questions in this Section. Answer any **THREE**.

Symbols carry their usual meaning. Assume any reasonable value for missing data.

5. (a) Calculate the reactions of the beam shown in Fig. 8. Use the Flexibility Method. Given:  $E = 3000 \text{ ksi}$ . (21 2/3)  
 (b) Calculate deformations of the free degrees of freedom of the frame shown in Fig. 9. Use the Stiffness Method. Ignore axial deformation of the beam only. Given:  $A = 10 \text{ in}^2$ ,  $I = 1000 \text{ in}^4$ ,  $E = 3000 \text{ ksi}$  for all the members. (25)
6. (a) Draw bending moment diagram of the beam shown in Fig. 10 using the Stiffness Method. Given:  $I = 1000 \text{ in}^4$ ,  $E = 3000 \text{ ksi}$ . (25)  
 (b) Write down the Stiffness equations in matrix form for the structure shown in Fig. 11. Assume  $E, I, J, G$  are constant. (21 2/3)
7. (a) Write down the Stiffness equations in matrix form for the truss shown in Fig. 12. Given:  $E = 30,000 \text{ ksi}$ . (21 2/3)  
 (b) Identify the nodes and members of the beam in Fig. 13 to analyze it using Stiffness method for computer application. Derive stiffness matrix of each member and assemble them into global stiffness matrix. Derive member load matrix and global load matrix. Write down the stiffness equations in matrix form for the unsupported structure. Given:  $E = 3000 \text{ ksi}$ , and  $I = 1000 \text{ in}^4$ . (25)

**CE 411**

8. For the truss shown in Fig. 14, write down the co-ordinate matrix, connectivity matrix, member property matrix, loaded node matrix, stiffness matrix of each member and global stiffness matrix of the truss. Consider support conditions and write down the modified stiffness equations. Given:  $E = 30,000$  ksi. Member areas are given in parenthesis.

(46<sup>2</sup>/<sub>3</sub>)

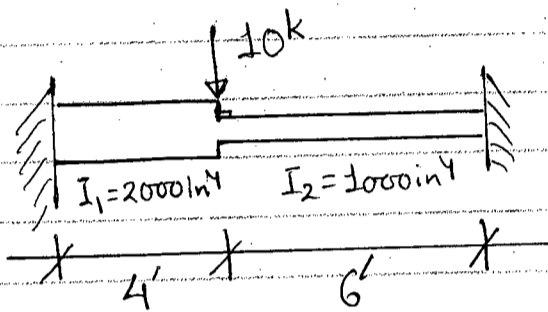

Fig. 8

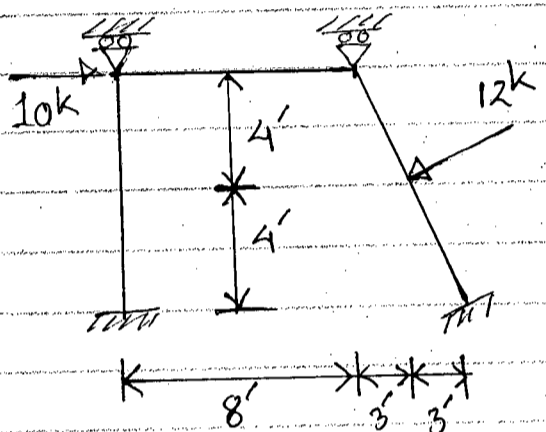

Fig. 9

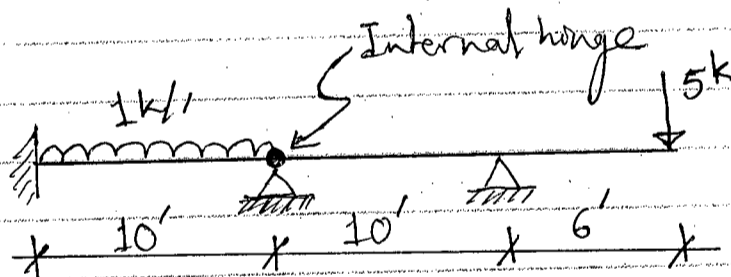

Fig. 10

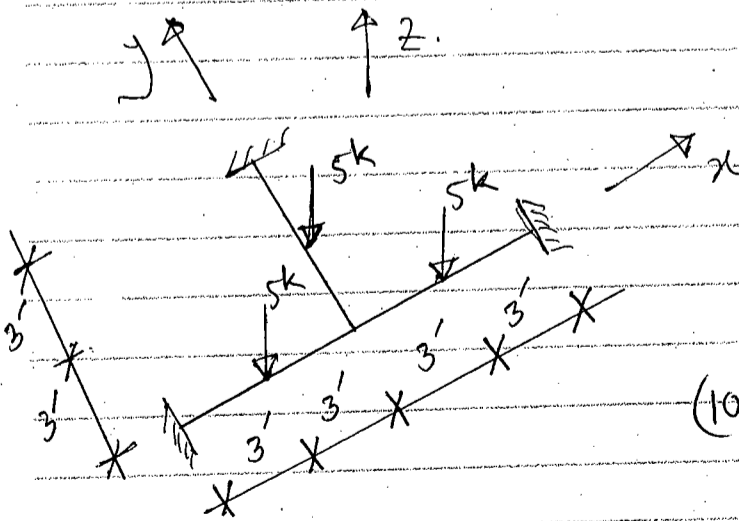

Fig. 11

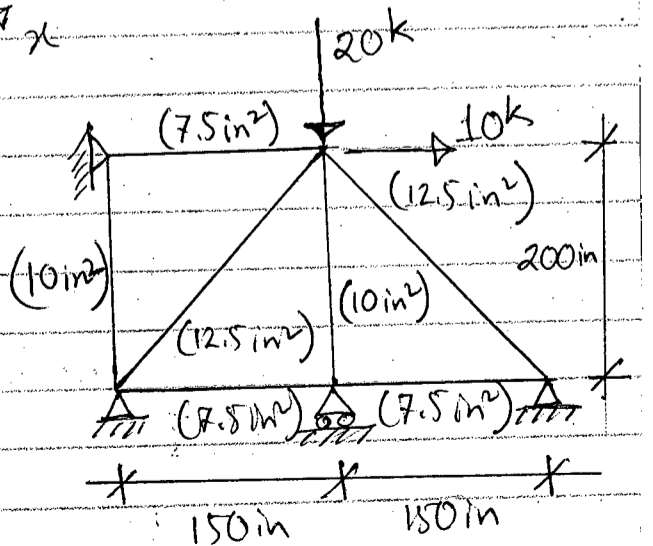

Fig. 12



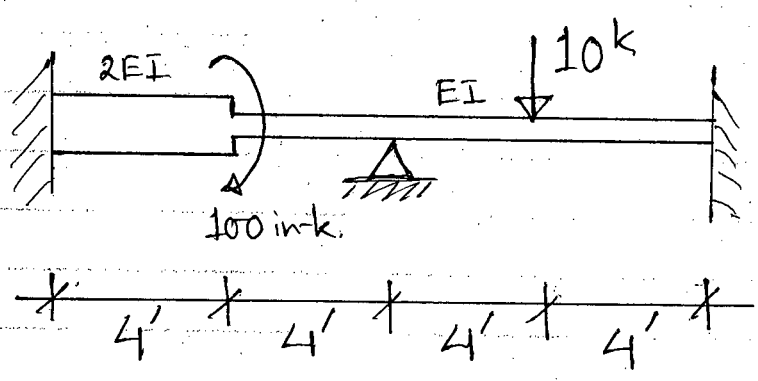

Fig. 13

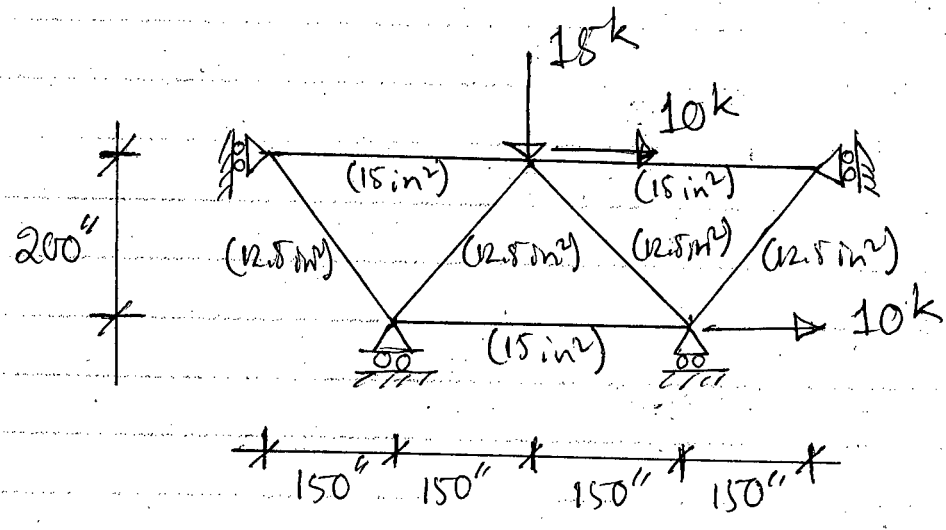

Fig. 14

The figures in the margin indicate full marks.

Assume reasonable value if not given.

USE SEPARATE SCRIPTS FOR EACH SECTION

**SECTION – A**

There are **FOUR** questions in this section. Answer any **THREE**.

1. (a) Write short notes on (i) Culturable command area, (ii) Sodium Adsorption Ratio, (iii) Duty and Delta, (iv) Canal lining, and (v) Kor depth and Kor period. **(15)**
- (b) Discuss the quality of irrigation water based on sodium concentration in water. **(5)**
- (c) A watercourse commands an irrigation area of 900 ha. The intensity of irrigation of rice in this area is 60%. The transplantation of rice takes 15 days and a total depth of water required by the crop is 50 cm on the field during transplantation period, given that the rain falling on the field during this period is 10 cm. (i) Find the duty of irrigation water for the crop on the field during transplantation; (ii) Find the duty at the head of distributary assuming losses of water to be 10% in the water courses and (iii) Calculate the discharge required in the watercourse. **(10)**
- (d) With neat sketch, show the different types of subsurface drainage layout. **(5)**
2. (a) Discuss the engineering measures for flood control by improving the conveyance of the natural drainage system. **(10)**
- (b) Write short notes on (i) Salt balance, (ii) Leaching requirement, (iii) Drainage coefficient and (iv) Chemical treatment. **(10)**
- (c) An irrigated area has to be provided with the drains so that the water table lies at least 2 m below the ground surface. The drains are spaced at 20 m c/c and are placed 3 m below the ground surface. Find the maximum rate of flow in each of the drains if they are 200 m in length. Depth of the impervious stratum below ground surface is 5 m and  $k = 0.001$  cm/sec. **(10)**
- (d) What are the limitations of Kennedy's theory for the design of channels? **(5)**
3. (a) State the necessity of drainage. What are the different types of drains in common use? Discuss briefly some of the field investigations necessary for drainage works. **(4+2+4)**

**WRE 401**

**Contd ... Q. No. 3**

(b) An area of 40,000 ha has to be irrigated by a canal for growing wheat; water requirement for which is 10 cm per month. Design and draw a suitable canal section with the data given below: (15)

Mean slope of the ground = 1 in 3400

Manning's,  $n = 0.025$

Side slope = 1 : 1

Use Kennedy formula.

(c) What is meant by 'balancing depth' and how is it determined? (5)

(d) Write advantages of 'berm' of an irrigation canal. (5)

4. (a) Briefly describe following flood fighting measures: (12)

(i) Ringing of sand boils

(ii) Heightening to stop overtopping

(iii) Closure of crevasses and breaches

(iv) Drainage of landslide levee slope

(b) Design a concrete lined channel to carry a discharge of 30 cumec at a slope of 10 cm/km. The side slopes of the channel are 1 : 1. The value of  $n$  may be taken as 0.015. (10)

(c) Mention the various factors affecting canal seepage losses. (5)

(d) Explain preventive anti-water logging measures. (8)

**SECTION - B**

There are **FOUR** questions in this section. Answer any **THREE**.

The symbols have their usual meanings.

5. (a) Distinguish between (3×3)

(i) Mass water content and volumetric water content

(ii) Available water and hygroscopic water

(iii) Instantaneous intake rate and average intake rate

(b) Why measurement of soil moisture is important? Compare electro-resistance block and neutron method of measuring soil moisture. (2+5=7)

(c) The field capacity and permanent wilting point of soil of a 0.5 ha wheat field are 28% and 13% respectively. The effective root zone depth is 80 cm and the bulk density of soil is 1.5 gm/cc. (8+6=14)

(i) Determine the net depth of irrigation if moisture level in the soil is to be maintained at no less than one-third of available water.

(ii) Determine the time required to irrigate the field with a stream of 20 l/s assuming an application loss of 30%.

(d) Explain why loam soils are considered more suitable for crop production. (5)

**WRE 401**

6. (a) State the factors affecting infiltration characteristics of soil. (5)
- (b) Explain why the concepts of water storage and water distribution efficiencies are necessary to evaluate field irrigation practices. Also explain why these efficiencies of 100% are not always desirable. (5+5=10)
- (c) An area of 1.2 ha was irrigated with a stream of 30 l/s in 12 hours. Depth of root zone was 1.2 m, available water holding capacity of the soil was 18 cm/m. Irrigation water was applied when 45% of available water was depleted. The average depth of penetration of water in each 0.2 ha segment of the field was 0.70 m, 0.98 m, 1.10 m, 0.95 m, 1.07 m and 0.85 m. (6+6=12)
- (i) Determine water storage efficiency if water application efficiency was 70%
- (ii) Also determine water distribution efficiency
- (d) What are the climatic factors affecting evapotranspiration? Explain the soil moisture depletion method to determine consumptive use of a field crop. (3+5=8)
7. (a) Write short notes on: (4+4=8)
- (i) Soil moisture stress
- (ii) Pump characteristic curves
- (b) The average weather data for a period of one month recorded at a certain place are given below: (14)
- Maximum temperature = 35°C
- Minimum temperature = 25°C
- Average temperature = 30°C
- Maximum relative humidity = 55%
- Minimum relative humidity = 45%
- Wind speed at 2 m above ground = 150 cm/s
- Net radiation = 18.16 MJ/m<sup>2</sup> per day
- Soil heat flux = 0.16 MJ/m<sup>2</sup> per day
- Slope of vapor pressure-temperature graph = 0.312 kPa/°C
- The psychrometric constant = 0.69 kPa/°C
- Effective rainfall = 8 cm
- (i) Calculate evapotranspiration of a crop if the crop coefficient is 0.92. Use FAO Penman-Monteith equation.
- (ii) What will be the field irrigation requirement of that month if water application efficiency is 75%.

**WRE 401**

**Contd ... Q. No. 7(b)**

Given,

$$ET_0 = \frac{0.408\Delta(R_n - G) + \gamma \left( \frac{900}{T + 273} \right) u_2 (e_s - e_a)}{\Delta + \gamma (1 + 0.34 u_2)}$$

- (c) State the conditions that favor the adoption of sprinkler irrigation. Also state the limitations. (5+2=7)
- (d) Describe the working principle of a centrifugal pump with a neat sketch. (6)

8. (a) Distinguish between (5+5=10)

- (i) Weir type escape and sluice type escape
- (ii) Aqueduct and syphon aqueduct

(b) Write down the main functions of the following structures with a neat sketch: (3×3=9)

- (i) Under-sluices
- (ii) Canal head regulator
- (iii) River training works

(c) A direct driven centrifugal pump coupled to a three-phase electric motor is installed in a deep open well. The discharge rate of the pump is 0.018 m<sup>3</sup>/s. The efficiency of the pump is 70%. The total static head is 20 m. The head losses are tabulated below: (4+3+3=10)

Item	Suction pipe	Discharge pipe	Bend of discharge pipe
Head loss (m)	2.25	3.75	1.50

The efficiency of the motor is 80%. Compute

- (i) Water horse power
- (ii) Brake horse power
- (iii) The cost of electrical energy to operate the pump for 12 hours daily in the month of May. The cost of electrical energy is Tk. 5 per unit.

(d) State the requirements of a good module. (6)

-----

**SECTION – A**

There are **FOUR** questions in this section. Answer any **THREE**.

1. (a) What are the objectives of water supply and drainage systems of a building? State the uses of valves in the water supply system. (10)
- (b) List the underlying principles of design of water supply piping of a building. Why flush-tank fixtures in stead of flush-valve fixture are used in the top floors of a tall building? Explain. (10)
- (c) Discuss the impact of humans upon the environment. How engineered processes differ from natural processes in treating pollutants? (11  $\frac{2}{3}$ )
- (d) Determine the zoning of a tall building from the following data: (15)
  - 30-story building, 10 ft floor to floor.
  - 50 psi at public main.
  - 4 psi loss in water meter.
  - 7 psi loss in piping and fittings of upfeed zone.
  - Flush-valve fixtures except on 29th and 30th floors where flush-tank fixtures are used.
  - 6 psi highest minimum fixture pressure for flush-tank fixtures.
  - 12 psi highest minimum fixture pressure for flush-valve fixtures.
  - Maximum pressure at any fixture is not to exceed 50 psi.

Assume reasonable value for any missing data.
2. (a) Define fixture, fixture unit, and fixture trap. What do you mean by strength of a trap? How is it determined? (10)
- (b) Describe the principal plumbing systems of drainage. Which system do you prefer and why? Explain. (12  $\frac{2}{3}$ )
- (c) Discuss briefly the criteria of measuring sustainable performance of water supply and sanitation systems. What are the merits of community participation in water and sanitation services? (15)
- (d) What is sanitation? Differentiate between 100% sanitation and total sanitation. (9)

**CE 333**

3. (a) What are the advantages and disadvantages of simple pit latrines? List the general design considerations of simple pit latrines. (12)
- (b) Describe a "Reed Odourless Earth Closet (ROEC)" with a neat sketch. What are the advantages and disadvantages of a ROEC? (12)
- (c) State the functions of pour-flush latrines. Discuss its suitability in Bangladesh. (12 2/3)
- (d) A farmer excavated a pit measuring 2.0 m × 2.0 m × 2.5 m (depth) for construction of a latrine. The family has 8 members and they do not like to see excreta while defecating. The water availability is limited and the groundwater table is very low. Anal cleansing practice is by using water. Design a suitable sanitary latrine to be built over the excavated pit. (10)
4. (a) Draw a gooseneck type water seal. What are the problems associated with this type of trap? How will you design pour-flush leach pits? (10)
- (b) What are the functions of a septic tank? State its design procedure. How can you improve septic tank effluent quality? (18 2/3)
- (c) List the technical advantages of small bore sewerage system. Discuss its applicability in Bangladesh. (12)
- (d) A septic tank serves a household of 6 persons who produce 60 lpcd of wastewater. Design a soakage pit for the disposal of effluent from the septic tank. The soil is silty loam with a long term infiltration rate of 25 l/m<sup>2</sup>-day. (6)

**SECTION – B**

There are **FOUR** questions in this section. Answer any **THREE**.

5. (a) A WWTP discharge treated effluent into the Shitalakkhya River upstream of the Saidabad WTP. One day it suddenly failed discharging untreated effluent into the River before it was repaired. The BOD (g/m<sup>3</sup>) data recorded during that period given below. (22 2/3)

Time (hour)	BOD (g/m <sup>3</sup> )	Time (hour)	BOD (g/m <sup>3</sup> )	Time (hour)	BOD (g/m <sup>3</sup> )
0100	34	0900	540	1700	154
0200	55	1000	526	1800	130
0300	219	1100	465	1900	100
0400	274	1200	450	2000	111
0500	300	1300	369	2100	110
0600	787	1400	362	2200	89
0700	998	1500	265	2300	77
0800	578	1600	172	2400	48

**CE 333**

**Contd ... Q. No. 5(a)**

- (i) Plot the data on log-probability paper supplied and determine the statistical parameters: geometric mean, geometric standard deviation and coefficient of variation (show the mathematical computation). Also, determine the geometric standard deviation from the probability plot.
- (ii) Comment on the nature of these statistical parameters and their implications to the Saidabad WTP located downstream.
- (iii) Assuming the same probability distribution to be valid for a prolonged repair period, determine the number of days in a year the BOD values of the discharge are expected to exceed  $150 \text{ g/m}^3$ .

(b) Draw the sectional view and plan of a Bell mouth junction where two different sized circular sewers meet at an acute angle. (10)

(c) Discuss briefly the role of bacteria in sewage treatment. (14)

6. (a) Define BOD and COD. (6)

(b) (i) Define Sustained Peak Factor. Explain why sustained loading diagram will be necessary if a central effluent treatment plant is constructed in DEPZ to treat the effluents from different industries. (20<sup>2</sup>/<sub>3</sub>)

(ii) Why is it necessary to have a sustained low constituent loading diagram in a WWTP with biological treatment facility?

(c) Differentiate between: (8)

- (i)  $\alpha$  and  $\beta$  (corrections in the performance of an aerator)
- (ii) Infiltration and Exfiltration in a sewer system.

(d) The 5-day BOD at  $20^\circ\text{C}$  of a waste is  $280 \text{ mg/L}$ . The Ultimate BOD is reported to be  $410 \text{ mg/L}$ . At what rate the waste is being oxidized? Determine  $\text{BOD}_5$  at  $25^\circ\text{C}$ . (12)

7. (a) In the figure below identify the sampling locations to assess the performance of the activated sludge unit of ETP. Provide brief explanation to justify your answer. (8)

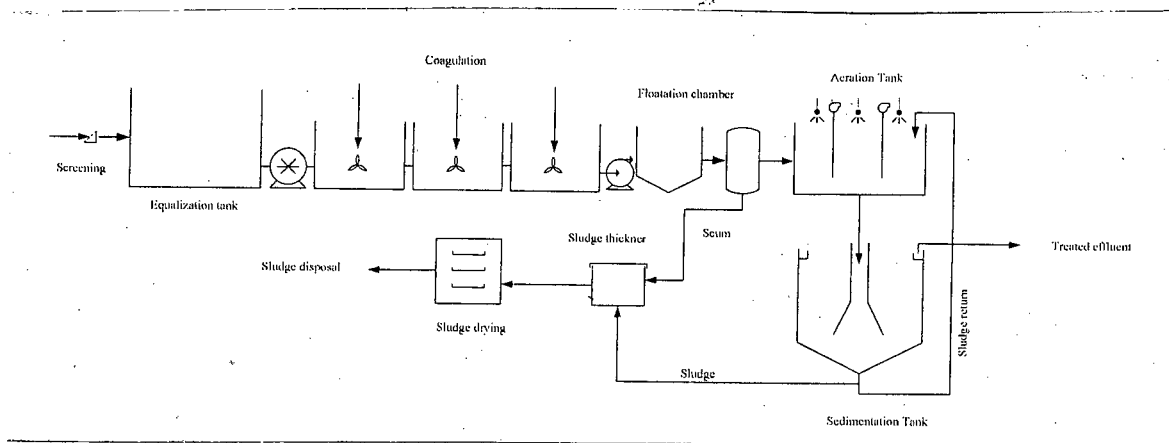



**CE 333**

**Contd ... Q. No. 7**

(b) Define "Equalization Tank" based on the necessity for such a tank in an ETP. (10)

(c) A new Separate Storm Sewer line is being constructed in the Dhanmondi R/A to reduce the water-logging problem during the rainy season. The following figure shows a schematic diagram of part of the new line. Following values were used for design of this part of the sewer system. Design the sewers for Catchment areas 1 and 2 and the Trunk sewer along with the Invert levels at the manholes shown in the figure.

**(28<sup>2</sup>/<sub>3</sub>)**

Catchment 1:	Catchment 2:
Area = 4 acres; (10-yr) Rainfall = 32. in/hr;	Area = 10 acres; (10-yr) Rainfall = 32. in/hr;
Runoff coefficient = 0.70	Runoff coefficient = 0.80
Length of the Road # 4 = 300 m	Length of the Road # 7 = 300 m

General Data:

- Infiltration rate = No infiltration allowed;
- Assume that the calculated surface runoff is equivalent to the peak flow rate;
- Use Rational formula to estimate surface runoff;
- Minimum pipe size: the local building code specifies 200 mm as the smallest pipe size permissible for this situation;
- Minimum velocity: Use a minimum velocity of 0.75 m/sec;
- Minimum cover: Minimum depth of cover over the top of the sewer is 2.0 m;
- Use nomograph provided; assume any reasonable value, if necessary.

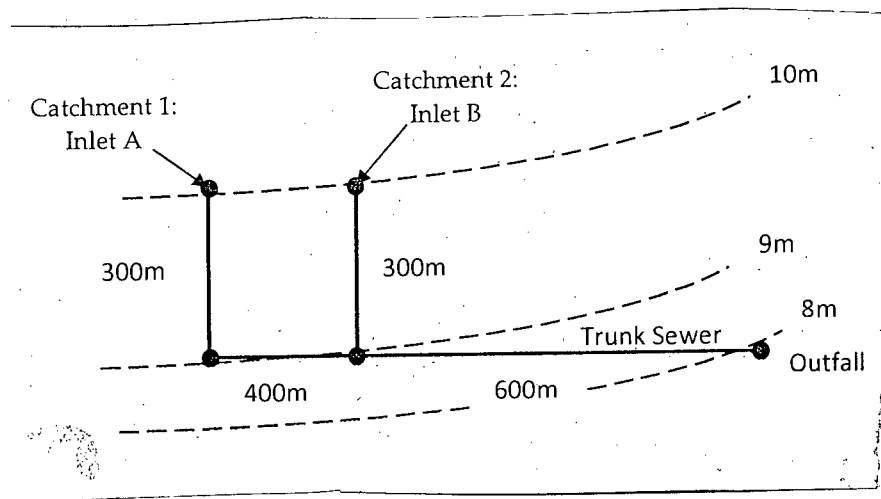

**CE 333**

8. (a) "The oxygen requirement in an aerated lagoon is the ultimate soluble BOD removed less the ultimate BOD due to the cells wasted in the effluent" – justify the statement. **(14<sup>2</sup>/<sub>3</sub>)**

(b) State and prove Marai's theorem. Deduce an expression to calculate the efficiency of BOD removal of a facultative pond. **(20)**

(c) Check the volumetric loading and surface loading of waste stabilization ponds with the following data: **(12)**

$$L_1 = 630 \text{ mg/L}, \quad T = 20^\circ\text{C}, \quad Q = 1000 \text{ m}^3/\text{d},$$

Mid-depth area of facultative pond = 70,000 m<sup>2</sup>, depth of facultative pond = 1.5 m

Assume any reasonable value for missing data (if required).

-----

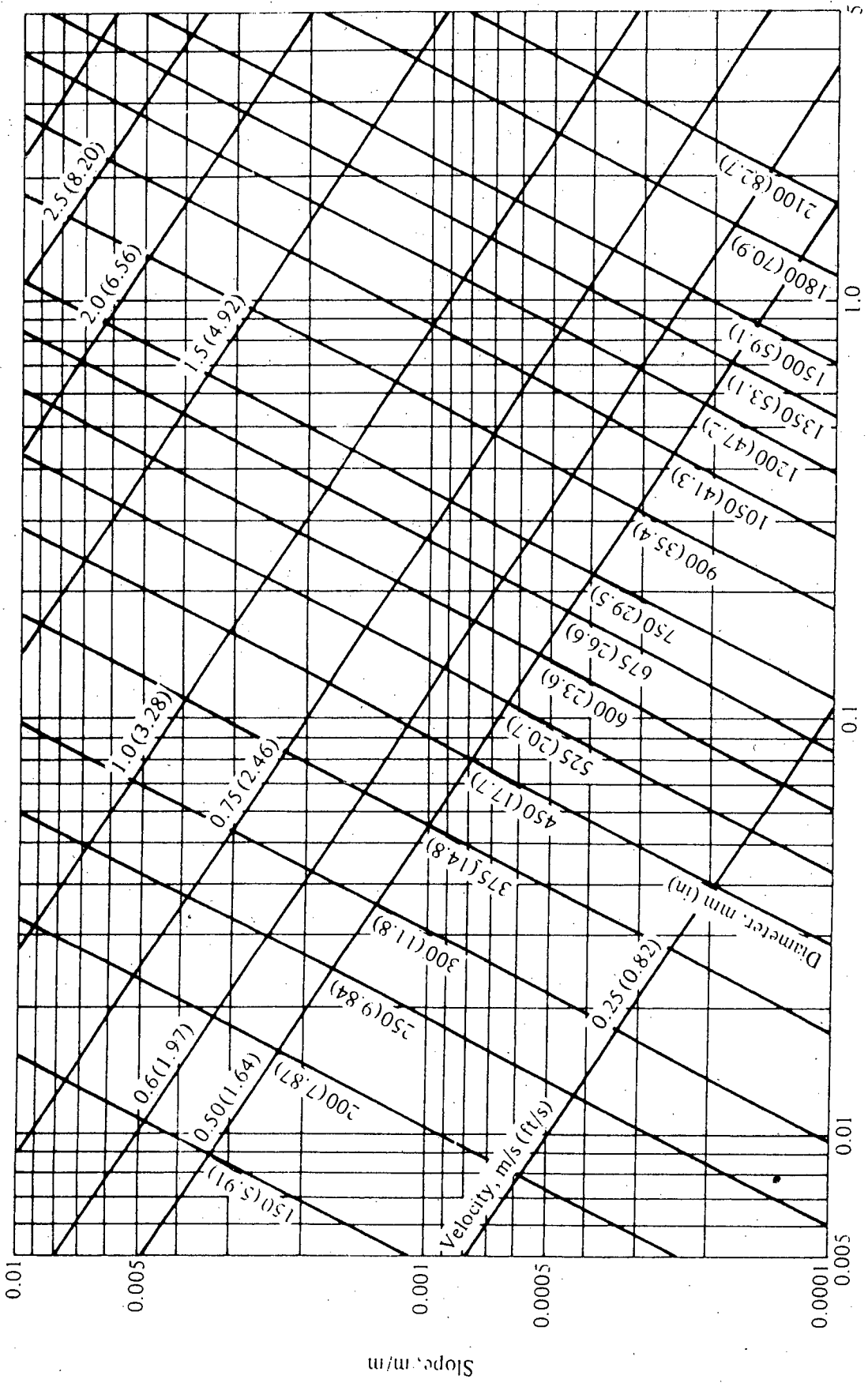
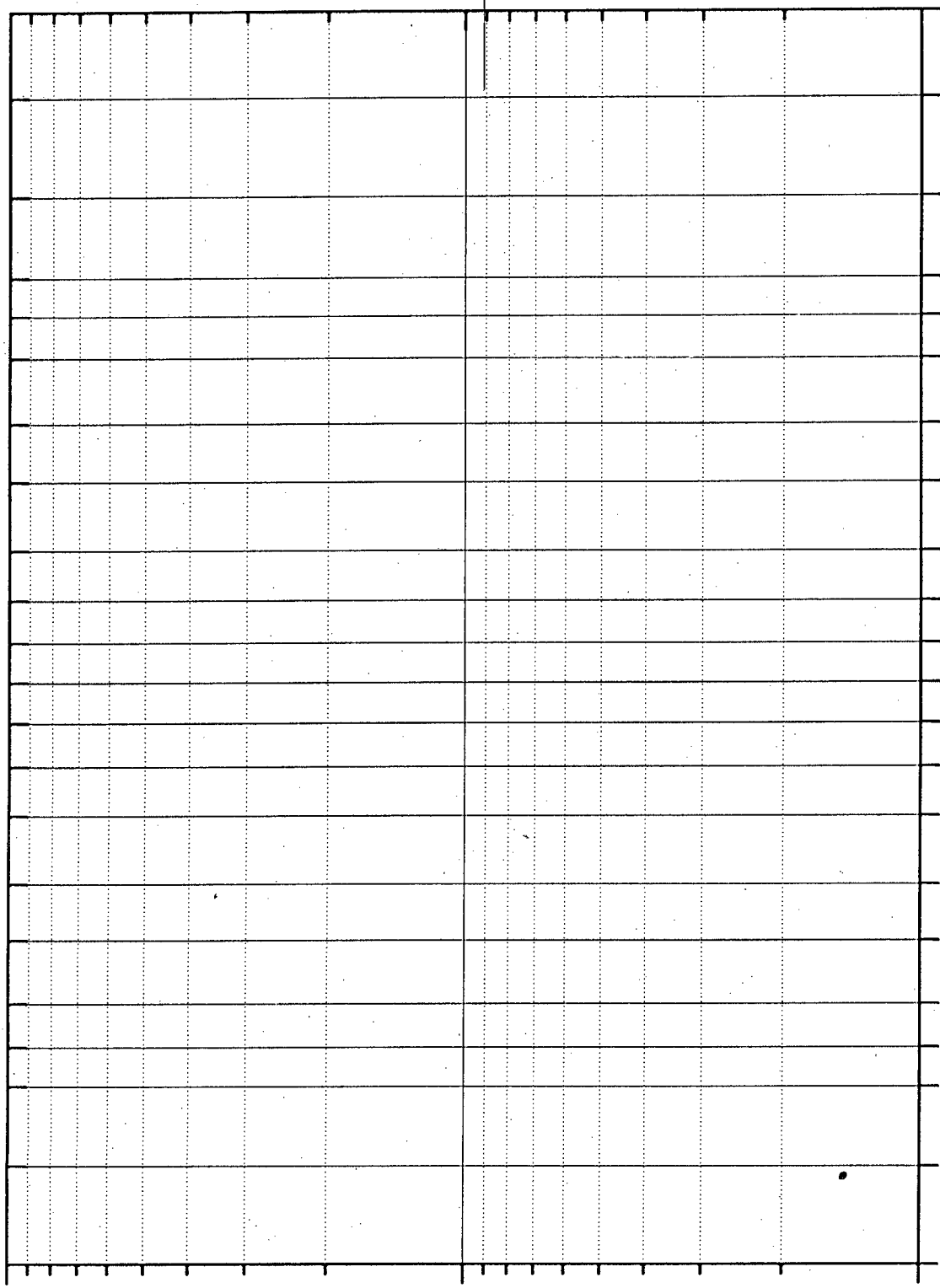

Figure 1 Nomograph for solution of Manning's equation for  $n = 0.013$ .

356

0.01 0.1 0.5 1 2 5 10 20 30 40 50 60 70 80 90 95 98 9999.5 99.9 99.99 99.999



0.01 0.1 0.5 1 2 5 10 20 30 40 50 60 70 80 90 95 98 9999.5 99.9 99.99 99.999

*[Handwritten signature]*

*[Handwritten signature]*