

SECTION – A

There are **FOUR** questions in this Section. Answer any **THREE**.

1. (a) Explain graphically the concepts of marginal utility and total utility. (10)
 (b) What are the assumptions of the cardinal theory of utility maximisation? Explain. (5)
 (c) Mathematically derive the cardinal theory of consumer equilibrium both for independent and interdependent commodities. (20)

2. (a) What is meant by change in demand and change in the quantity demanded? Explain graphically the above changes with reference to the change in prices of substitute and complementary commodities. (10)
 (b) Define market equilibrium. Describe how the price of a commodity in the market is determined. (10)
 (c) Calculate the equilibrium price and quantity from the following demand and supply functions and show the result in a graph. (15)

$$QD_x = 4000 - 400 P_x$$

$$QS_x = - 500 + 500 P_a$$
 (i) If a per unit tax of Tk. 0.90 is imposed, how will it effect the equilibrium price and quantity?
 (ii) If Government provides a subsidy of Tk. 2 per unit, what will happen to the equilibrium price and quantity?

3. (a) What does the elasticity of demand measure in general? Define price elasticity of demand, write down its formula and give example. (10)
 (b) Prove the following properties of indifference curve. (10)
 (i) An indifference curve slopes downwards from left to right
 (ii) Indifference curves are normally convex to the origin.
 (c) What is meant by a price consumption line? Derive a demand curve from a price consumption line and show that price effect is equal to substitution effect and income effect. Present and explain all necessary diagrams. (15)

4. (a) What do you understand by localization of industries? What are the main causes of localization of industries? (15)
 (b) Explain the advantages of localization of industries. (10)
 (c) What are the disadvantages of division of labour? Explain. (10)

HUM 277

SECTION - B

There are **FOUR** questions in this Section. Answer any **THREE**.

5. (a) When does a firm emerge as a monopolist? (10)
(b) Explain the short-run equilibrium of a firm under monopoly. (10)
(c) Prove that $MR = P \left(1 - \frac{1}{e}\right)$ where (10)
MR = Marginal revenue
P = price
e = price elasticity of demand
(d) Why is there no unique supply curve for the monopolist derived from his MC curve? (5)
6. (a) Explain the long-run equilibrium of a firm under perfect competition. (15)
(b) From the following revenue and cost functions, calculate profit maximizing level of output and maximum profit. (10)
 $R = 1200 Q - 2Q^2$
 $C = Q^3 - 61.25Q^2 + 1538.5Q + 2000$
(c) What are the assumptions of a perfectly competitive market? Explain them. (10)
7. (a) Define fixed cost and variable cost. (10)
(b) How would you derive the long-run average cost curve of a firm from its short-run average cost curves? (15)
(c) What is the relation among various short-run cost curves? Explain graphically. (10)
8. (a) What are the methods of measuring national income? Explain. (10)
(b) What are the problems of measuring national income? (15)
(c) From the following model calculate equilibrium level of income and multiplier. (10)
 $C = 100 + 0.75 Y_D$
 $I = 200$
 $G = 300$
 $X = 50$
 $M = 150$
 $TR = 100$
 $T = 0.15 Y$
(Here the symbols bear their usual meaning.)
-

BANGLADESH UNIVERSITY OF ENGINEERING AND TECHNOLOGY, DHAKA

L-2/T-1 B. Sc. Engineering Examinations 2010-2011

Sub : **EEE 203** (Energy Conversion – I)

Full Marks: 210

Time : 3 Hours

The questions are of equal value.

USE SEPARATE SCRIPTS FOR EACH SECTION

SECTION – A

There are **FOUR** questions in this Section. Answer any **THREE**.

1. (a) Draw the phasor diagrams of single phase transformer at the secondary side by neglecting the effect of excitation at lagging, leading and unit power factor loads. From these phasor diagrams derive the formula for no-load voltage:

$$\frac{V_p}{a} = V_s + R_{eqs} I_s \cos\theta + X_{eqs} I_s \sin\theta, \text{ where the symbols have their usual meanings.}$$

How regulation and efficiency of transformer are found out?

- (b) A 20 kVA 8000/480 V distribution transformer has the following resistances and reactances:

$$R_p = 32 \Omega, X_p = 45 \Omega, R_c = 250 \text{ k}\Omega, R_s = 0.05 \Omega, X_s = 0.06 \Omega, X_M = 30 \text{ k}\Omega.$$

The excitation branch impedances are given referred to the high-voltage side of the transformer.

- (i) Find the equivalent circuit of this transformer referred to the high-voltage side.
 (ii) Find the per-unit equivalent circuit of this transformer. (iii) Assume that this transformer is supplying rated load at 480 V and 0.8 pF lagging. What is this transformer's input voltage? What is its voltage regulation? What is the transformer's efficiency under this condition?
2. (a) What is an autotransformer? What are the advantages and disadvantages of autotransformer if compared with conventional transformer? Find the expression of "apparent power rating advantage" when a transformer is connected as autotransformer. Why short circuit fault current increases when a conventional two winding transformer is connected as an autotransformer?
 (b) Explain the problem of current inrush at starting of a transformer. What is the difference between the inrush current and the fault current of a transformer in terms of their wave shapes?
3. (a) Explain why tertiary winding is used in a Y-Y connected three-phase transformer. Why tertiary winding is not required if one side of the three-phase transformer is Δ -connected. What is the meaning of DY-1 of vector group of three-phase transformer?

EEE 203

Contd ... Q. No. 3

(b) A 20 kVA, 20,000/480 V, 60 Hz distribution transformer is tested with the following results:

| Open-circuit test (measured from secondary side) | Short-circuit test (measured from primary side) |
|---|--|
| $V_{OC} = 480 \text{ V}$ | $V_{SC} = 1130 \text{ V}$ |
| $I_{OC} = 1.6 \text{ A}$ | $I_{SC} = 1.00 \text{ A}$ |
| $P_{OC} = 305 \text{ W}$ | $P_{SC} = 260 \text{ W}$ |

(i) Find the per-unit equivalent circuit for this transformer at 60 Hz. (ii) What would the rating of this transformer be if it were operated on a 50 Hz power system?

4. (a) Explain the conditions to be fulfilled by two three-phase transformers to operate them in parallel. Why parallel operation of transformers is required?

(b) A single-phase power system is shown in the figure. The power source feeds a 100 kVA 14/2.4 kV transformer through a feeder of impedance $40 + j150 \Omega$. The transformer's equivalent series impedance referred to its low-voltage side is $0.12 + j0.5 \Omega$. The load on the transformer is 90 kW at 0.8 pF lagging and 2300 V.

(i) What is the voltage at the power source of the system? (ii) What is the voltage regulation of the transformer? (iii) How efficient is the overall power system?

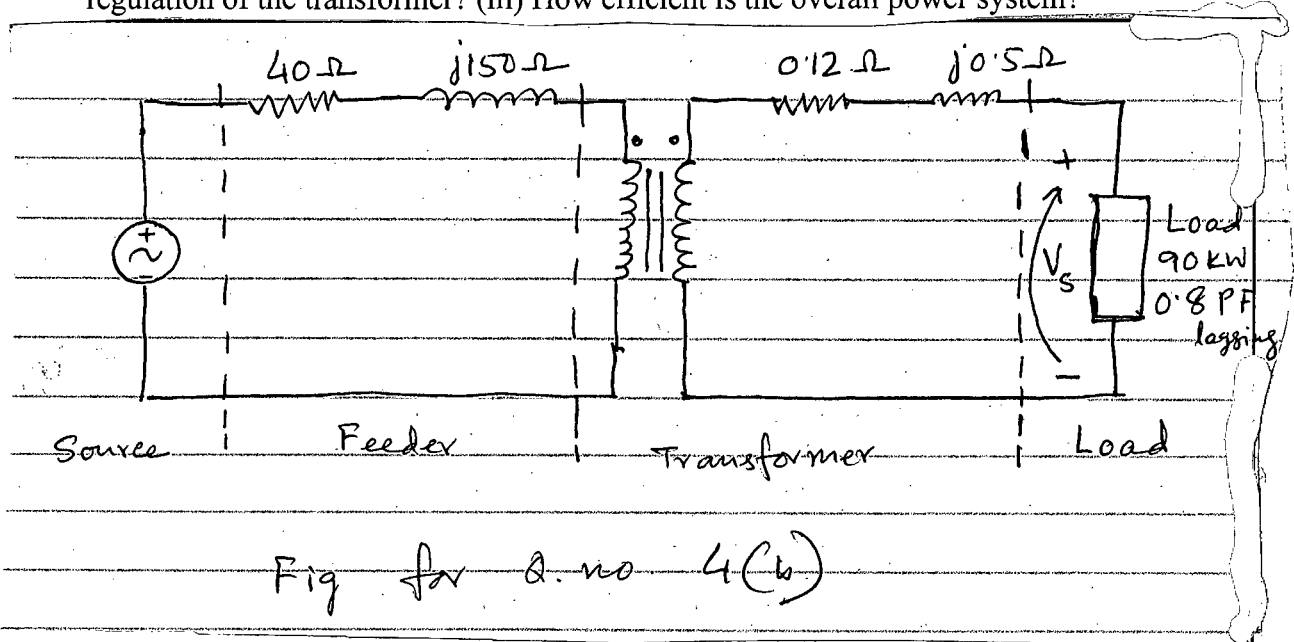

SECTION - B

There are **FOUR** questions in this Section. Answer any **THREE**.

5. (a) Three coils of 2-conductors each (180° in space) are displaced by 120° in space [Fig Q 5(a)]. The coils are supplied by three phase currents,

$$i_a = I_m \sin \omega t, i_b = I_m \sin(\omega t - 120) \text{ and } i_c = I_m \sin(\omega t - 240).$$

EEE 203

Contd ... Q. No. 5(a)

Prove mathematically that a resultant flux will be produced in the air that rotates at a synchronous speed.

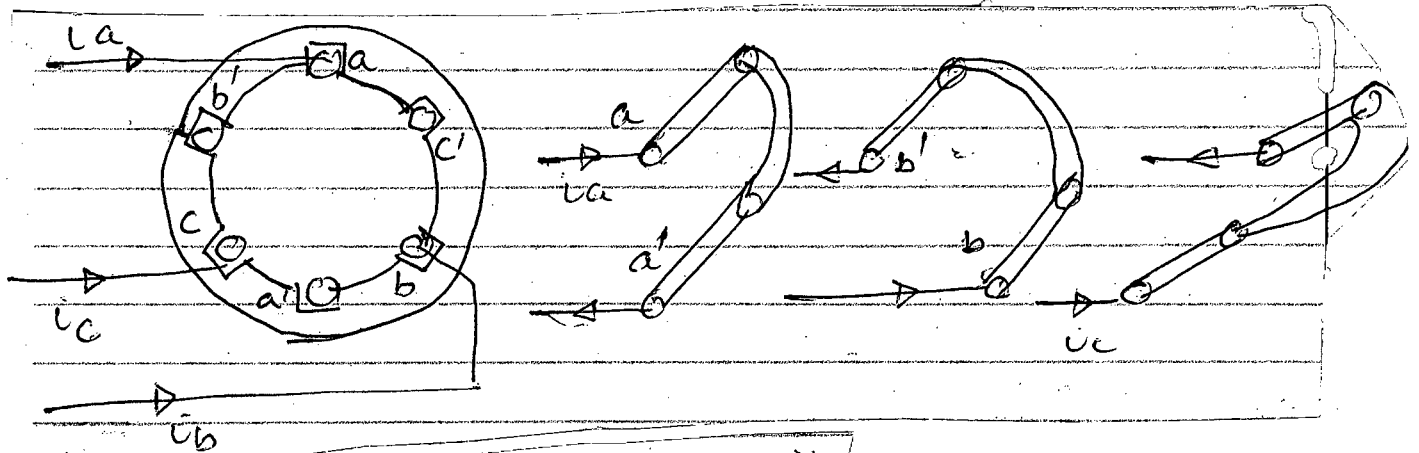

Fig for Q.5(a)

(b) A 440 V, 50 Hz, 2-pole, Y connected motor is rated at 75 kW. The per phase equivalent circuit parameters are,

$$R_S = 0.075 \Omega \quad R_r = 0.065 \Omega \quad X_m = 7.2 \Omega$$

$$X_S = 0.17 \Omega \quad X_{BR} = 0.17 \Omega$$

$$P_{\text{friction+windage}} = 1000 \text{ W} \quad P_{\text{misc}} = 150 \text{ W} \quad P_{\text{core}} = 1100 \text{ W}$$

Find the following,

- (i) Slip at maximum torque developed,
- (ii) N_r at maximum torque developed,
- (iii) I_r at maximum torque developed,
- (iv) Airgap power at maximum torque developed,
- (v) Maximum torque developed,
- (vi) output power (shaft power) at maximum torque developed,
- (vii) output torque (shaft torque) at maximum torque developed,
- (viii) input power using relationship $3 V_P I_P \cos \theta_{V_P I_P}$
(V_P and I_P are phase voltage and phase current of stator)
- (ix) Efficiency of the motor in percent.

All symbols have their usual meaning.

6. (a) A 208 V, 60 Hz (US motor), 6 pole, Y-connected 25 hp design class B induction motor is tested in the laboratory with the following results.

| | |
|--------------------|---------------------------------------|
| No load Test | 208 V, 22 A, 1200 W (total), 60 Hz |
| Blocked Rotor Test | 24.6 V, 64.5 A, 2200 W (total), 15 Hz |
| DC Test | 13.5 V, 64 A |

Find the equivalent circuit parameters of the motor per phase.

(b) Name and describe the methods of controlling the speed of induction motors. (Provide neat schematic diagrams).

EEE 203

7. (a) With proper motor equations, explain the shape of torque-speed (or speed) characteristics of three phase induction motors for,
- (i) Variation of supply voltage (all other parameters remaining constant),
 - (ii) Variation of motor resistance (all other parameters remaining constant) and
 - (iii) Variation of supply frequency (all other parameters remaining constant).
- (b) Prove that in the three phase induction motor, maximum torque developed is independent of its rotor resistance R_r .
8. (a) How a single phase induction motor is made self-starting? Describe any two methods of making a single phase induction motor self starting.
- (b) Write short notes on any three of the following,
- (i) Principle of operation of a single phase induction motor based on double revolving field theory,
 - (ii) Dynamic braking of a 3-phase induction motor,
 - (iii) Wye-Delta Starter of a 3-phase induction motor,
 - (iv) Equivalent circuit of a single phase induction motor and equations of P_{gnet} (Net airgap power), P_{md} (power developed), T_{md} (torque developed) and P_{out} (shaft power) of a single phase induction motor.
-

SECTION – A

There are **FOUR** questions in this Section. Answer any **THREE**.

Symbols used have their usual meaning.

1. (a) Define Nilpotent and Unitary matrices with examples. Prove that for all positive integral indices of the powers of a Hermitian matrix is a Hermitian matrix. (9)

(b) For the matrix $C = \begin{bmatrix} 1 & 0 & 2 \\ 1 & 1 & 0 \\ 1 & 2 & 3 \end{bmatrix}$ verify that $C(\text{adj}C) = |C|I_3$. Find the inverse of C as

well. (12)

(c) Reduce $A = \begin{bmatrix} 1 & -2 & 1 & 3 \\ 4 & -1 & 5 & 8 \\ 2 & 3 & 3 & 2 \end{bmatrix}$ to the Normal form B and Compute the matrices P and

Q such that $PAQ = B$, where A and B are equivalent matrices. (14)

2. (a) Show that the absolute value of each latent root of an orthogonal matrix A is unity. (5)

(b) State and verify Cayley-Hamilton theorem for the matrix $E = \begin{bmatrix} 1 & -1 & 1 \\ 1 & 2 & 1 \\ 1 & 0 & 3 \end{bmatrix}$. Hence

find E^5 . (15)

(c) Find all proper roots, proper vectors and eigen spaces for the matrix

$$G = \begin{bmatrix} 5 & 3 & -1 \\ 3 & 5 & -1 \\ -3 & -3 & 3 \end{bmatrix}. \quad (15)$$

3. (a) Define Rank of a matrix. Is the following system of linear non-homogeneous equations inconsistent? If no, then solve with the help of matrix: (17)

$$x_1 + x_2 - 3x_3 + x_4 + 5x_5 = 4$$

$$2x_1 - x_2 + 2x_4 + 10x_5 = 8$$

$$3x_1 + 2x_2 - 7x_3 - 3x_4 - 3x_5 = 12$$

MATH 259

Contd ... Q. No. 3

(b) Define right and left quotients of a matrix. If $P = \begin{bmatrix} 2 & 1 & 5 \\ 0 & 2 & 1 \\ 0 & 0 & 2 \end{bmatrix}$ and $Q = \begin{bmatrix} 1 & 2 & 3 \\ 4 & 5 & 0 \\ 6 & 7 & 8 \end{bmatrix}$,

find the left and right quotients of P by Q . (12)

(c) Find the equation of the circle which passes through the points $(-3, -5)$, $(1, -5)$ and $(-3, 1)$. (6)

4. (a) Find the degree of minimal polynomial of the matrix $A = \begin{bmatrix} 6 & 2 & -2 \\ 2 & 3 & -1 \\ -2 & -1 & 3 \end{bmatrix}$. Is the

matrix A derogatory or not? If yes, then express characteristic polynomial as the product of minimal polynomial and one of its monic factors. (17)

(b) Define quadratic form of the matrix. Reduce the quadratic form $q = x_1^2 + 2x_2^2 - 3x_3^2 + 8x_1x_2 + 10x_1x_3 - 16x_2x_3$ to the Canonical form and find rank, index and signature of q . Also write down the corresponding equations of transformation. (18)

SECTION - B

There are **FOUR** questions in this Section. Answer any **THREE**.

5. (a) Find the standard matrix for the transformation T on \mathbb{R}^3 , where T is the composition of a rotation of 30° about x -axis, followed by a reflection about xz -plane, followed by a dilation with factor $k = 2$. Then find $T(3, -5, 7)$ using the standard matrix. (18)

(b) Find the eigen values and corresponding eigen vectors of the linear transformation T or \mathbb{R}^3 defined by the reflection about the xz -plane. Is the transformation one-to-one? If so, find the standard matrix for the inverse transformation of T . (17)

6. (a) (i) Find a subset of vectors $\underline{v}_1 = (1, -2, 0, 3)$, $\underline{v}_2 = (2, -5, -3, 6)$, $\underline{v}_3 = (-1, 4, 6, -3)$, $\underline{v}_4 = (2, -1, 4, -7)$ and $\underline{v}_5 = (7, -7, 11, -5)$ that forms a basis for the space spanned by these vectors. (ii) Express each vector not in the basis as a linear combination of the basis vectors. (17)

(b) Find the Kernel and Range of (i) orthogonal projection on yz -plane; (ii) orthogonal projection on the plane defined by $y = z$. Write down a basis and the dimension of Kernel and Range in each case. (18)

MATH 259

7. (a) Find a basis for the row space of $A = \begin{bmatrix} 2 & 2 & -1 & 0 & 1 \\ -1 & -1 & 2 & -3 & 1 \\ 1 & 1 & -2 & 0 & -1 \\ 0 & 0 & 1 & 1 & 1 \end{bmatrix}$ (17)

Consisting entirely of row vectors from A. Find the null space of A and write down the basis of null space. Also verify the dimension theorem for the matrix A.

(b) Determine whether the following subsets are subspaces of \mathbf{R}^4 . If so, then find their dimensions. (18)

(i) all vectors of the form (a, b, c, d) , where $d = 3a + 5c$ and $4c = 2a - 3b$.

(ii) all vectors of the form $(a, b, c, 0)$, where $2b = 7c$.

8. (a) Let $T: P_2 \rightarrow P_3$ be the linear transformation defined by $T(p(x)) = xp(x)$. Find the matrix for T with respect to the standard bases $B = \{u_1, u_2, u_3\}$ and $B' = \{v_1, v_2, v_3, v_4\}$ where $u_1 = 1, u_2 = x, u_3 = x^2$; $v_1 = 1, v_2 = x, v_3 = x^2, v_4 = x^3$. Then verify that $[T]_{B',B}[X]_B = [T(X)]_{B'}$. (17)

(b) Consider the vector space \mathbf{R}^3 with the Euclidean inner product. Apply Gram-Schmidt process to transform the basis vectors, $u_1 = (1, 1, 1)$, $u_2 = (0, 1, 1)$ and $u_3 = (1, 1, 0)$ into a orthogonal basis $\{v_1, v_2, v_3\}$; then normalize the orthogonal basis vectors to obtain the orthonormal basis $\{q_1, q_2, q_3\}$. (18)

SECTION – A

There are **FOUR** questions in this Section. Answer any **THREE** questions including

Question No. 1 as compulsory.

1. (a) Explain with reference to the context any two of the following: (15)
- (i) "They were watching me as they would watch a conjurer about to perform a trick."
 - (ii) "We want to be rescued; and of course we shall be rescued."
 - (iii) "But the more I read the more complicated the subject seemed to me and the more conscious I grew of my ignorance."
- (b) Attempt any one of the following: (15)
- (i) Write a note on Orwell's view on imperialism.
 - (ii) 'The swine has cheated me!' — Who said this? What light does it throw on the speaker's own character? Elucidate.
- (c) Answer any three of the following questions: (15)
- (i) Who was Guru Nayak? How was he entrapped by the astrologer?
 - (ii) What lesson do you learn from your study of The Use of Philosophy?
 - (iii) Give a penpicture of the death scene of the elephant.
 - (iv) What was the reaction to the killing of the elephant?
 - (v) What plan did the boys in 'FIRE ON THE MOUNTAIN' make for their rescue?
2. (a) Recast and correct any ten of the following sentences: (15)
- (i) The boys knows to swim.
 - (ii) It is long since we have met each other.
 - (iii) She proceeded as though I have not spoken.
 - (iv) If I had reached there in time I have then caught the bus.
 - (v) How long you are waiting for your friends?
 - (vi) It is you who has broken the glasses.

HUM 135

- (vii) The colour of the apples which was so attractive to look at was very enticing.
 - (viii) Let you and he go there.
 - (ix) Hardly had I entered into my house than the phone was ringing.
 - (x) I see you have made less mistakes this week.
 - (xi) They have money enough to afford a car.
 - (xii) Mother arose in her when she saw the baby.
- (b) Give meanings of and then make sentences with any ten of the following words:
Ajar, Menace, Phlegmatic, Aversion, Bellow, Entice, Promulgate, Castigate,
Brandish, Germinate, Grumble, Conscientious.

3. Amplify any one of the following ideas: (30)
- (a) Sweet are the uses of adversity.
 - (b) Prosperity brings friends, adversity tries them.

4. Write a precis of the following passage with a suitable title: (30)

We must build a world of peace and we cannot do so unless we secure for it a truly moral foundation. We may hold different metaphysical views, adopt different modes of worship and there are millions today who do not desire to place their faith in any God at all. But everyone of us will feel highly offended if he is pronounced destitute of any moral sense, if he is said to be untruthful or unloving. All religions and systems of morality agree that respect for life, respect for intangible possessions, good name and honour, constitute morality and justice. 'Do not do to others what you would not like to be done to you.' Even primitive sages accept this principle. Only for them its appreciation is limited to their own tribe and race and those outside are not regarded as human beings. As our horizon expands, as our moral sense deepens, we feel that these moral precepts are valid for all human beings. Today the world is like a ship with no captain heading for the rocks. It is swept by passion and folly. We do not know whether it is passing through birth pangs or death throes. If we adopt the path of greed, hatred and self interest, we will become something less than human. If we take the other path of fortitude, unselfish service and sacrifice we will reach the height of splendour in body, mind and spirit of which we can hardly dream. Non religion is our malady, and religion as an adventure of spirit and as a tool of radical transformation of human nature is the cure for it.

HUM 135

SECTION – B

There are **FOUR** questions in this Section. Answer any **THREE** questions including **Question No. 5** as compulsory.

5. Read the passage carefully and answer the questions that follow:

(45)

You seemed at first to take no notice of your school-fellows, or rather to set yourself against them because they were strangers to you. They knew as little of you as you did of them; so that this would have been the reason for their keeping aloof from you as well, which you would have felt as a hardship. Learn never to conceive a prejudice against other because you know nothing of them. It is bad reasoning, and makes enemies of half the world. Do not think ill of them till they behave ill to you; and then strive to avoid the faults which you see in them. This will disarm their hostility sooner than pique or resentment or complaint. I thought you were disposed to criticize the dress of some of the boys as not so good as your own. Never despise anyone for anything that he cannot help — least of all, for his poverty. I would wish you to keep up appearances yourself as a defence against the idle sneers of the world, but I would not wish you value yourself upon them. I hope you will never be the dupe nor victim of vulgar prejudices. Instead of saying above, "Never despise anyone for anything that he cannot help," I might have said, "Never despise anyone at all." For contempt implies a triumph over and pleasure in the ill of another. It means that you are glad and congratulate yourself on their failings or misfortunes.

You might have hitherto been a spoilt child, and have been used to have your own way a good deal, both in the house and among your playfellows, with whom you were too fond of being a leader; but you have good nature and good sense, and will get the better of this in time. You have now got among other boys who are your equals, or bigger and stronger than yourself and who have something else to attend to besides humouring your whims and fancies, and you feel this as a repulse or piece of injustice. But the first lesson to learn is that there are other people in the world besides yourself. The more airs of childish self-importance you give yourself, you will only expose yourself to be the more thwarted and laughed at. True equality is the only true morality or wisdom. Remember always that you are but one among others and you can hardly mistake your place in society. In your own house you might do as you pleased; in the world you will find competitors at every turn. You are not born to destroy or dictate to millions; you can only expect to share their fate, or settle your differences amicably with them.

Questions:

- (a) What reasons does the author give for not harbouring a prejudice against others?
- (b) What are some of the blessings of living with others in the same class or the same place?

Contd P/4

HUM 135

- (c) Comment on the statement, "contempt implies a triumph over and pleasure in the ill of another".
- (d) The author says that "in the world you will find competitors at every turn". But competition is a very good thing. Why does he seem to warn us about it?
- (e) What have you learnt from the passage? Express your own opinions on it.
6. (a) What is a report? Briefly discuss the frontmatter of a report. **(10)**
- (b) As the manager of a big shop you have received from one of your customers a letter complaining 30 typewriters out of 75, which they had ordered and received from your shop are faulty. Now he wants a replacement of all those 30 typewriters. Draft a suitable reply refusing replacement but suggesting an alternative which you think will satisfy them. **(10)**
- (c) Give phonetic spellings of the following words: (ANY five) **(10)**
Risk, Curious, Bright, Feather, Cloud, Dark.
7. (a) What do you understand by the term "semantic gap"? Give examples to illustrate your answer. **(05)**
- (b) Write a composition on any one of the following topics: **(15)**
- (i) Aspects and phenomena of Nature
 - (ii) Holidays
 - (iii) Books and Reading
- (c) Write a dialogue between two boys who have just come out of the examination-hall. **(10)**
8. (a) Transform the following sentences as directed. (ANY five) **(10)**
- (i) Men who have risen by their own exertions are always respected. (Make it Simple)
 - (ii) If he had not signed, he would have been executed. (Make it Compound)
 - (iii) I shall remain where I am. (Make it Simple)
 - (iv) He is poor, but contented. (Make it Complex)
 - (v) We sow so that we reap. (Make it Compound)
 - (vi) I always love my country. (Make it Negative)
- (b) Discuss briefly the principles of writing effective business letters. **(05)**
- (c) Write short notes on any three of the following: **(15)**
- (i) Interpretive Report
 - (ii) Thesis Statement
 - (iii) Features of Sales Letter
 - (iv) Vowels.
-

SECTION - A

There are **FOUR** questions in this Section. Answer any **THREE**.
The questions are of equal value.

1. (a) Draw a bridge rectifier circuit. The circuit is designed to produce a peak output voltage of 12 V, deliver 120 mA to the load, R_L and produce an output with a ripple of not more than 5 percent. Find (i) PIV, (ii) Capacitor C (iii) i_{davg} . Given : $f = 50$ Hz.
(b) The regulator shown in Fig. Q1(b) is to power a car radio at $V_L = 9V$ from an automobile battery whose voltage may vary between 11 and 13.6 V. The current in the radio

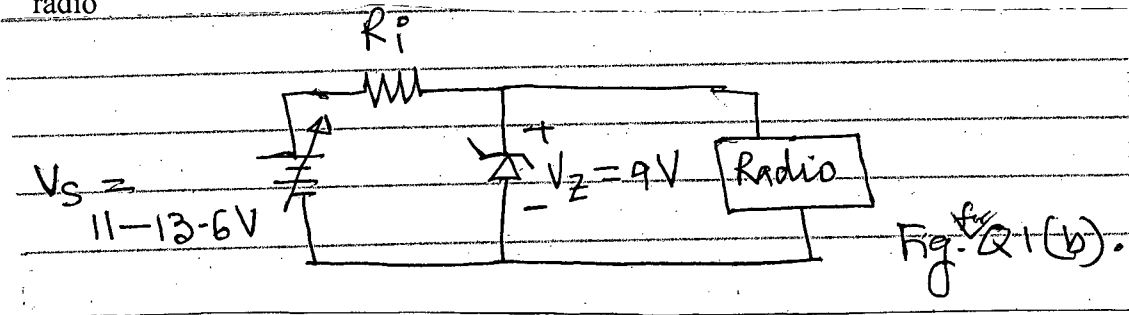

will vary between 0(off) to 100 mA (full volume). Find $I_Z(max)$, R_i and P_{R_i} (max).

[Hint : $R_i = \frac{V_s(max) - V_Z}{I_Z(min) + I_L(max)}$,

$R_i = \frac{V_s(max) - V_Z}{I_Z(max) + I_L(min)}$ and $I_Z(min) = 0.1 I_Z(max)$.

2. (a) In the circuit of Fig. Q. 2(a), both diodes are identical, conducting 10 mA at 0.7 V and 100 mA at 0.8V. Find the value of R for which $V = 80$ mV.

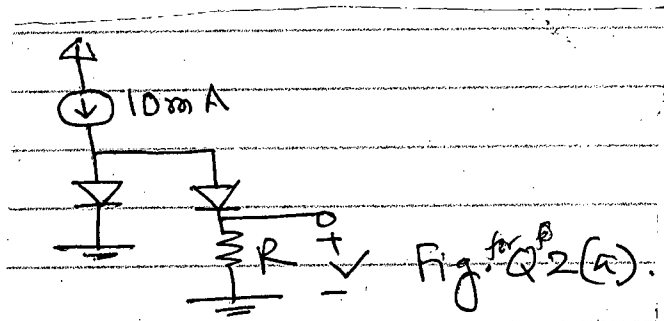

- (b) sketch and clearly label the waveform of v_o^+ and v_o^- of the circuit shown in Fig. Q 2(b). If the magnitude of the average of each output is to be 15 V, find the required amplitude of the

EEE 201

Contd ... Q. No. 2(b)

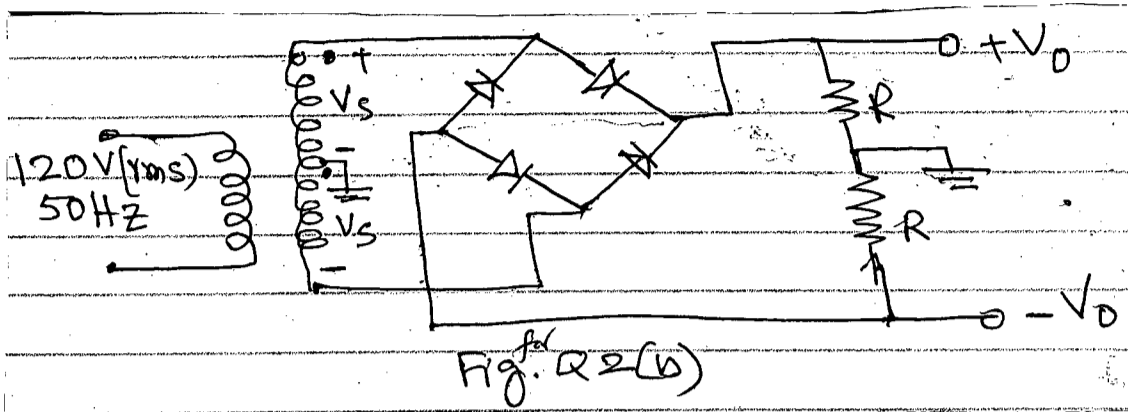

sine wave across the entire secondary. What is the PIV of each diode?

3. (a) Sketch v_o versus time for the circuit shown in Fig. Q 3(a) with the input shown. Diodes are identical. Given: $f = 50$ Hz.

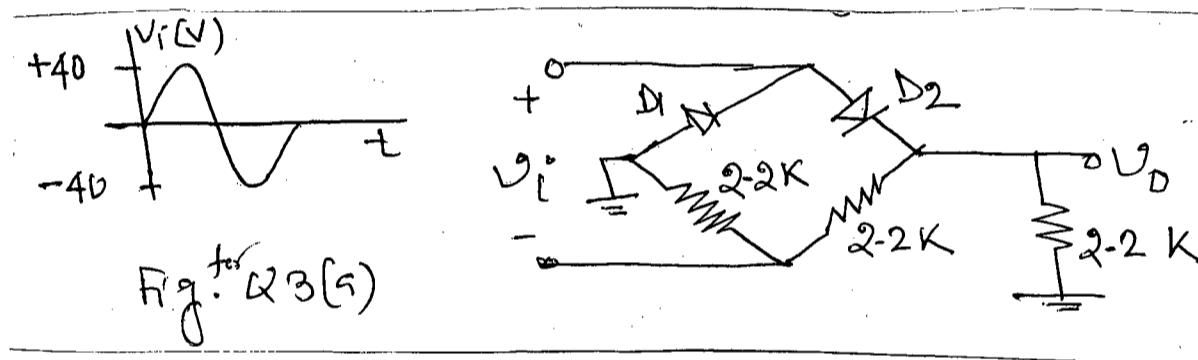

- (b) Find V_{GS} and R_D of the circuit shown in Fig. Q. 3(b). Given: $V_m = 0.8$ V, $K'_n = 80 \mu A/V^2$, $\frac{W}{L} = 3$, $I_D = 250 \mu A$ and $V_D = 2.5$ V.

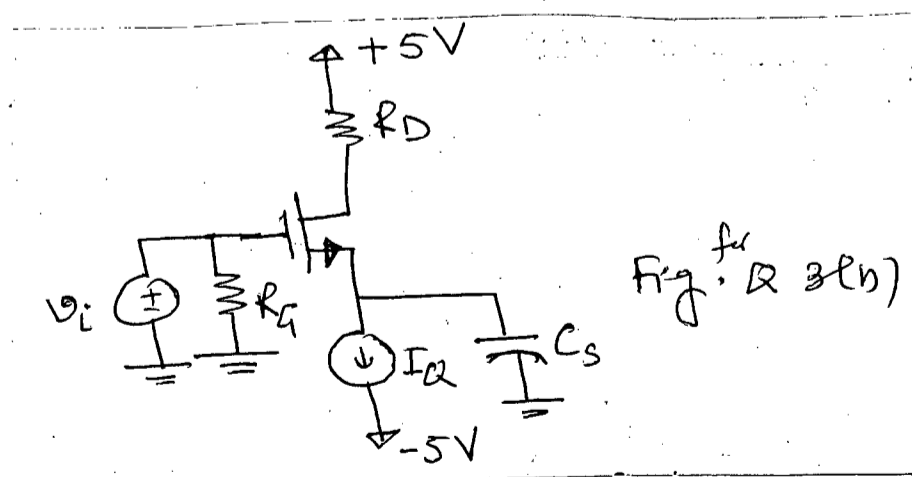

EEE 201
Contd ... Q. No. 3

(c) Find I_D and V_{GS} of the circuit shown in Fig. Q 3(c). Given: $V_m = 0.8$ V and $K'_n = 0.1$ mA/V².

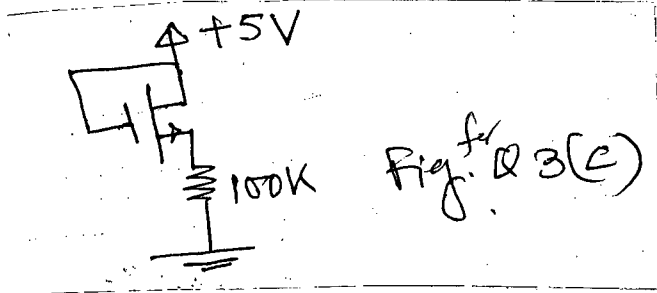

4. (a) Obtain V_{GS3} and I_Q for the biasing circuit shown in Fig. Q 4(a).

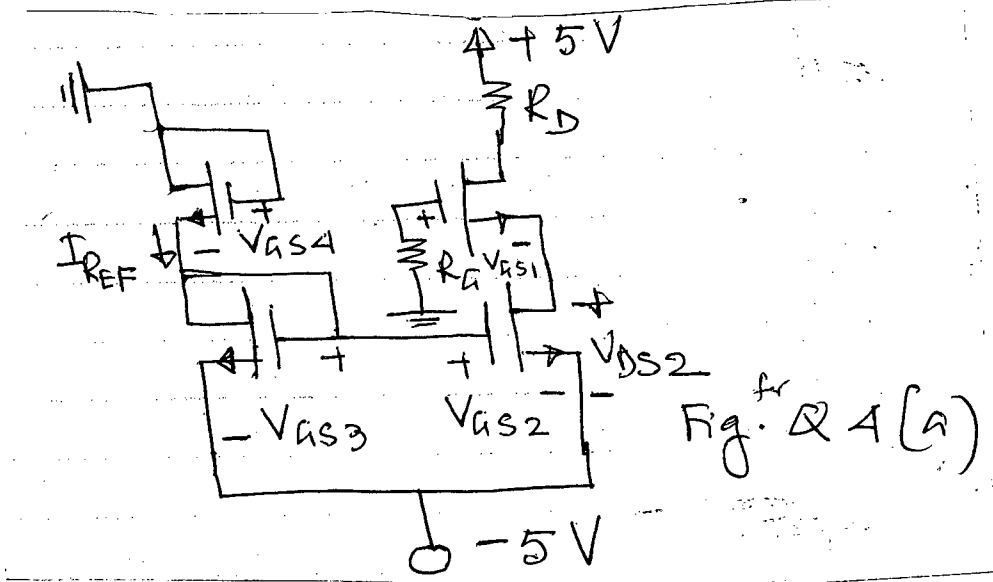

(b) For the circuit shown in Fig. Q 4(a), find V_{GS1} and V_{DS2} . Given: $K'_{n1} = 0.4$ mA/V²,

$$K'_{n2} = K'_{n3} = K'_{n4} = 0.1 \text{ mA/V}^2,$$

$$V_{tn1} = V_{tn2} = V_{tn3} = V_{tn4} = 1\text{V}.$$

SECTION - B

There are **FOUR** questions in this Section. Answer any **THREE**.
The symbols have their usual meanings.

5. (a) Name and compare different types of single stage MOS amplifiers.
 - (b) Starting from the π -equivalent model, derive the T equivalent model of a MOSFET.
 - (c) Draw the different biasing arrangement of BJT amplifier circuit and state their advantages and disadvantages.
6. (a) Derive the small signal model of a BJT and calculate base resistance, emitter resistance and voltage gain.
 - (b) For the common emitter amplifier with an emitter resistance circuit shown in Fig. 6(b). Calculate the input resistance (R_{in}). Output resistance (R_{out}), voltage gain (A_v), Open circuit voltage gain (A_{v0}), overall gain (G_v) and short circuit current gain (A_{is}).

EEE 201

7. (a) Draw the different biasing arrangements of MOS amplifier circuit and state their advantages and disadvantages.
 (b) For the circuit shown in Fig. 7(b), find the labelled node voltages when $\beta = 100$.
8. (a) For the Common-Drain amplifier circuit shown in Fig. 8(a), calculate input resistance, output resistance, voltage gain and overall gain. Why it is called a source follower?
 (b) For the circuit shown in Fig. 8(b), calculate voltage gain (v_o/v_i), input resistance (R_{in}) seen by the source v_s and the gain (v_o/v_s) if the source resistance is 75Ω .
 (c) For the circuit shown in Fig. 8(c), find the collector current I_C and V_{CE} , Use $\beta = 50$ and $V_{BE} = 0.7 V$.

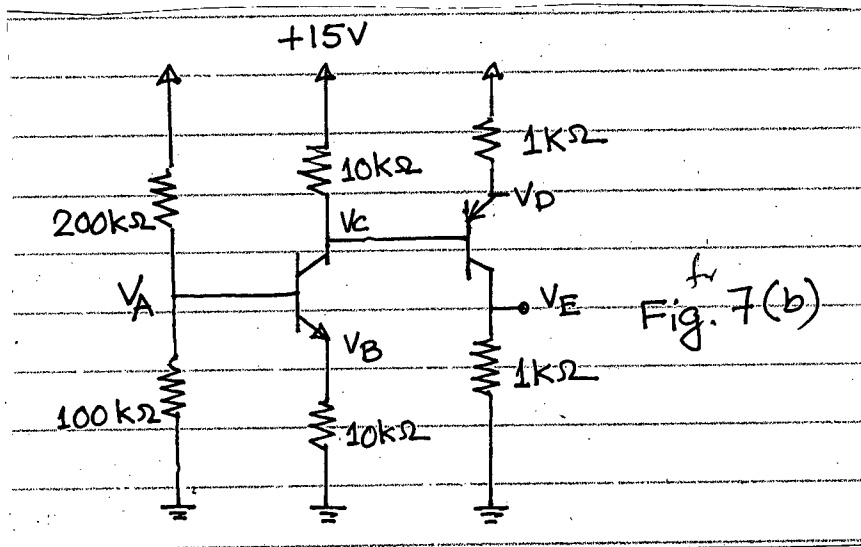
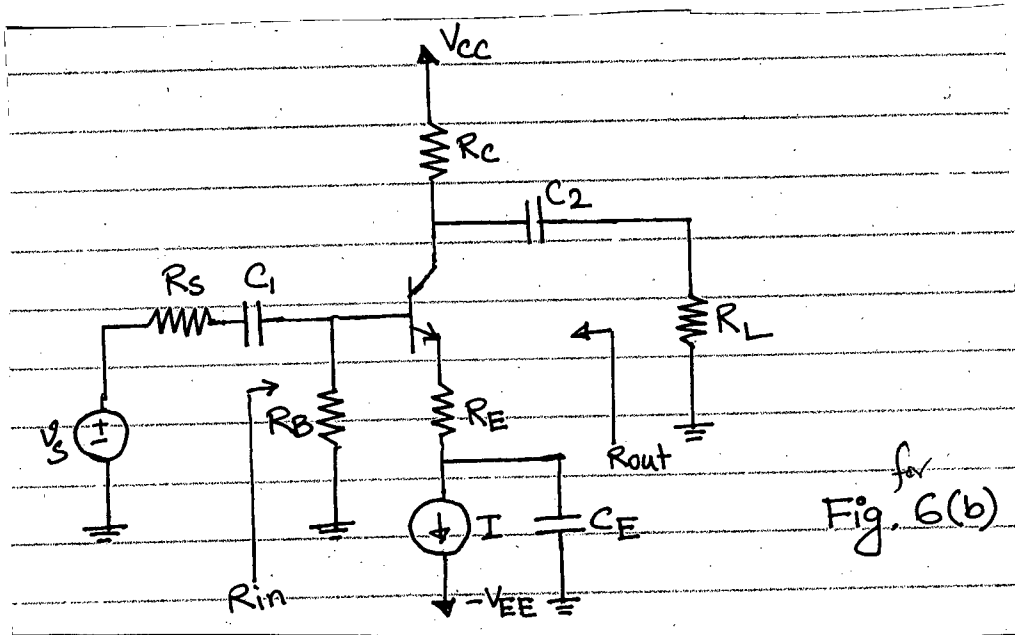

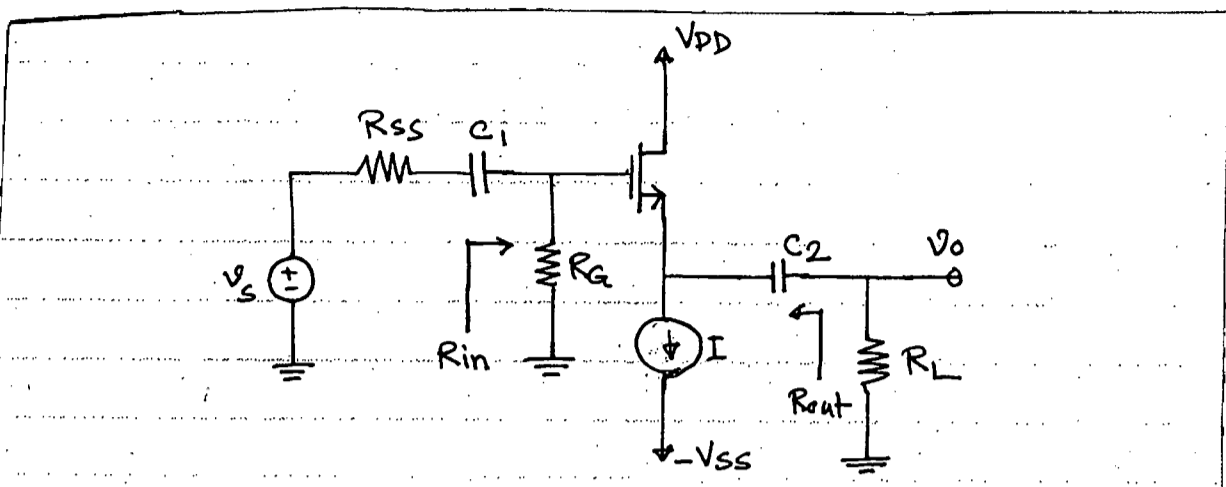

Fig. 8(a)

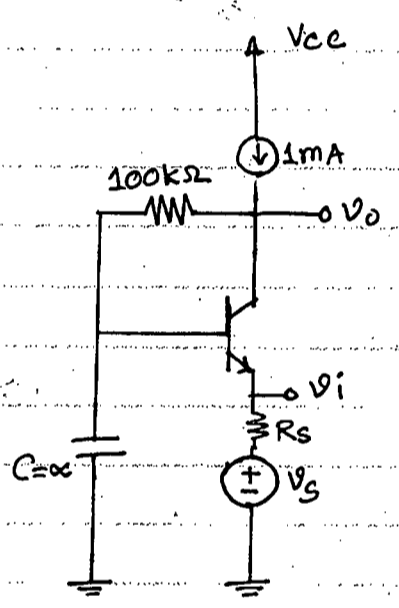

Fig. 8(b)

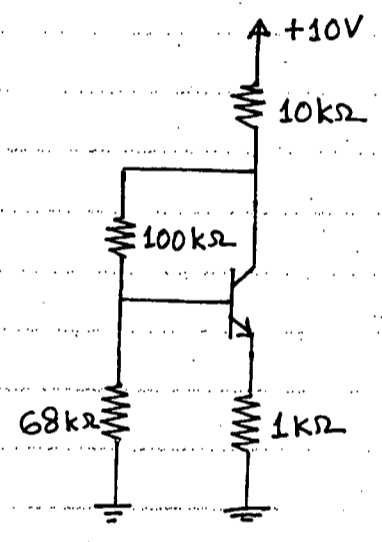

Fig. 8(c)