

BANGLADESH UNIVERSITY OF ENGINEERING AND TECHNOLOGY, DHAKA

L-1/T-1 B. Sc. Engineering Examinations 2010-2011

Sub : **ME 165** (Basic Mechanical Engineering)

Full Marks : 210

Time : 3 Hours

The figures in the margin indicate full marks.

USE SEPARATE SCRIPTS FOR EACH SECTION

**SECTION – A**There are **FOUR** questions in this Section. Answer any **THREE**.

Symbols have their usual meaning.

1. (a) Give a simplistic definition of Internal Combustion Engine. (6)
- (b) Classify engine on the basis of combustion method. (8)
- (c) Give a brief comparison between spark ignition and compression ignition engine. (9)
- (d) Draw the fuel supply system layout of a compression ignition engine having individual fuel pumps for each cylinder. (12)
2. (a) Describe the different parameters that are used to depict the specification of a robot. (15)
- (b) Describe briefly the basic components of a robot. (12)
- (c) Mention some notable applicants of robot. (8)
3. (a) What are the localized environmental concerns of air pollution? (7)
- (b) What do you know about LPG and CNG? (8)
- (c) Discuss the various concepts of extracting solar energy in brief. (10)
- (d) Describe briefly the extraction method of crude oil. (10)
4. (a) Mention the desirable properties of a refrigerant. (8)
- (b) What do you know about COP and RT? (8)
- (c) Briefly describe the working principle of a vapor compression refrigeration system with necessary diagram. (13)
- (d) Draw the schematic diagram of an all-air type central air conditioning system. (6)

**SECTION – B**There are **FOUR** questions in this Section. Answer any **THREE**.

Assume reasonable values for any missing data.

5. (a) The angle bracket shown in Fig. for Q. No. 5(a) has an angle,  $\alpha = 50^\circ$ . Replace the 600 N force by - (15)
  - (i) an equivalent force -couple system at C,
  - (ii) an equivalent system formed by two parallel forces at B and C.

**ME 165 (CSE)**

**Contd ... Q. No. 5**

- (b) A container of weight  $W$  shown in Fig. for Q No. 5(b), is suspended from ring A, to which cables AC and AE are attached. A force  $P$  is applied over a pulley at B and through ring A and which is attached to a support at D. Knowing that  $W = 1000 \text{ N}$ , determine the magnitude of  $P$ . (20)
6. (a) A parallel chord Pratt truss is loaded as shown in Fig. for Q. No. 6(a). Determine the force in members CE, DE and DF. (18)
- (b) The pulley, shown in Fig. for Q. No. 6(b), has a radius of 50 mm. Determine the components of the reactions at B and E. (17)
7. (a) A 6 kg block B, shown in Fig. for Q. No. 7(a), rests on the upper surface of a 10 kg block A. Neglecting friction, determine- (15)
- (i) the acceleration of block A,
  - (ii) the acceleration of block B relative to A, immediately after the system is released from rest.
- (b) The roller-coaster track, shown in Fig. for Q. No. 7(b), is contained in a vertical plane. The portion of track between A and B is straight and horizontal, while the portion to the left of A and to the right of B has radii of curvature as indicated. A car is travelling at a speed of 72 Km/h when the brakes are suddenly applied, causing the wheels of the car to slide on the track ( $\mu_k = 0.2$ ). Determine the initial deceleration of the car if the brakes are applied, as the car- (20)
- (i) has almost reached A,
  - (ii) is traveling between A and B,
  - (iii) has just passed B.
8. (a) A pulley and two loads are connected by inextensible cords as shown in Fig. for Q. No. 8(a). The pulley starts from rest at  $t = 0$  and is accelerated at the uniform rate of  $2.4 \text{ rad/s}^2$  clockwise. At  $t = 4\text{s}$ , determine the velocity and position - (15)
- (i) of load A,
  - (ii) of load B.
- (b) In the position shown in Fig. for Q. No. 8(b), bar AB has an angular velocity of  $4 \text{ rad/s}$  clockwise. Determine the angular velocity of bars BD and DE. (20)
-

ME 165 (CSE)

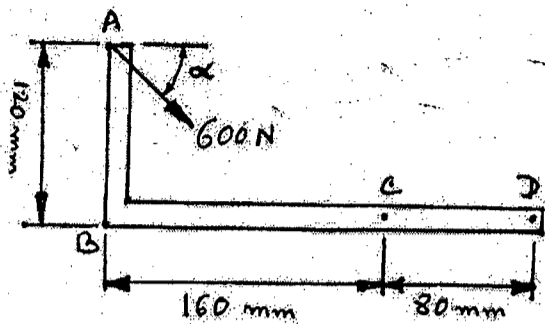

Fig. for Q. No. 5 (a)

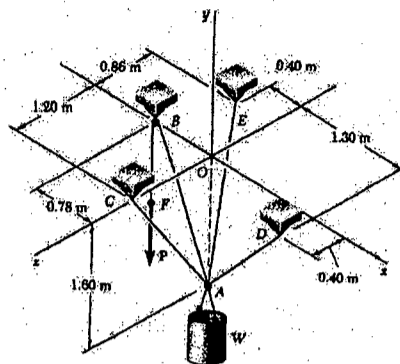

Fig. for Q. No. 5 (b)

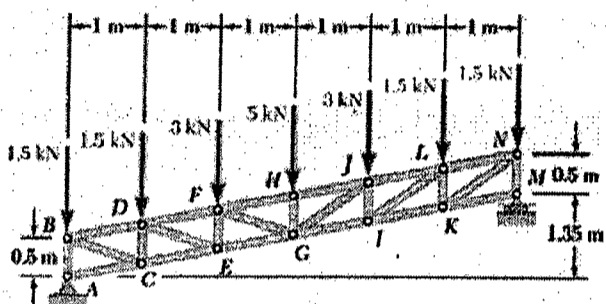

Fig. for Q. No. 6 (a)

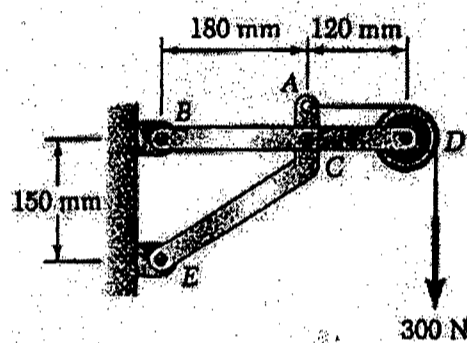

Fig. for Q. No. 6 (b)

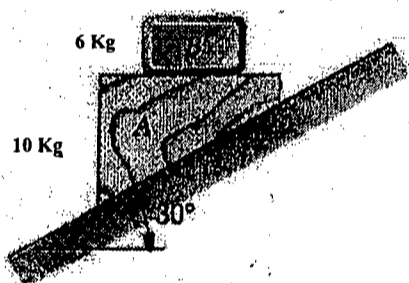

Fig. for Q. No. 7 (a)

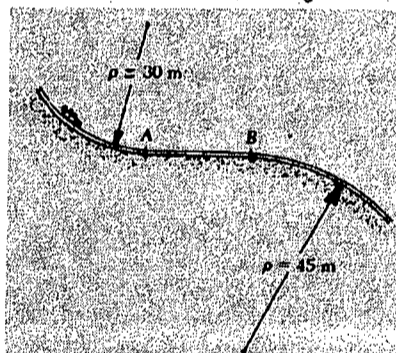

Fig. for Q. No. 7 (b)

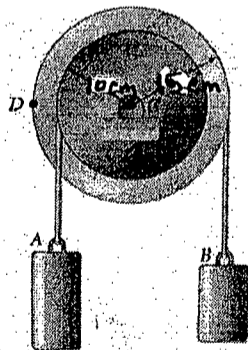

Fig. for Q. No. 8 (a)

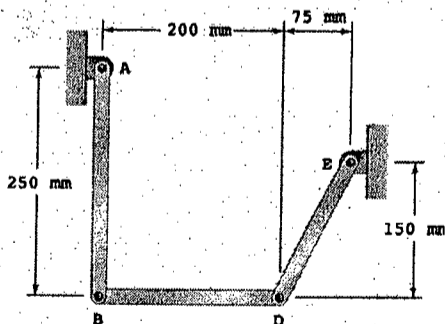

Fig. for Q. No. 8 (b)

**SECTION – A**

There are **FOUR** questions in this Section. Answer any **THREE**.

1. (a) Write down the differential equation of a forced oscillator. Solve it for steady state and show that at resonance the amplitude is maximum. Show graphically how the resonance curve varies with different damping coefficient. (8+20+6  $\frac{2}{3}$  = 34  $\frac{2}{3}$ )  
 (b) A 2.0 kg object oscillates on a spring of force constant  $k = 400$  N/m. The damping constant is  $b = 2.0$  kg/sec. It is driven by a sinusoidal force of maximum value 10 N and angular frequency 10 rad/sec. (i) What is the amplitude of the oscillations? (ii) If the driving frequency is varied, at what frequency will resonance occur? (iii) Find the amplitude of vibrations at resonance. (12)
  
2. (a) Derive an expression for the resultant vibration of a particle simultaneously acted upon by two simple harmonic vibrations along a line having same time period but different amplitude and phase difference. Find out the conditions for maximum and minimum amplitudes of the resultant. (14  $\frac{2}{3}$  + 7 = 21  $\frac{2}{3}$ )  
 (b) Give an example of rotational harmonic motion and find its time period. What are the differences between simple harmonic motion and rotational harmonic motion. (15)  
 (c) Two simple harmonic motions acting simultaneously on a particle are given by  $y_1 = \sin(\omega t + \frac{\pi}{3})$  and  $y_2 = 2 \sin \omega t$  (10)  
 Find the equation of the resultant vibration.
  
3. (a) State and explain the first law of thermodynamics. Prove that  $PV^\gamma = \text{Constant}$ , where the symbols have their usual meanings. (12+22  $\frac{2}{3}$  = 34  $\frac{2}{3}$ )  
 (b) A quantity of dry air at 27 °C is compressed, (i) slowly and (ii) suddenly to  $\frac{1}{3}$  of its volume. Find the change in temperature in each case. ( $\gamma = 1.4$  for dry air) (12)
  
4. (a) Describe a Carnot cycle. Obtain the expressions for the work done in each cycle of operation and the net work done in the cycle. (10+24  $\frac{2}{3}$  = 34  $\frac{2}{3}$ )

**PHY 109**

Contd ... Q. No. 4.

- (b) Find the efficiency of an engine requiring  $3 \times 10^6$  calories of heat per horse power hour and compare it with that of a perfect reversible engine, assuming that the source is at  $1000^\circ\text{C}$  and the sink is at  $0^\circ\text{C}$ . (1 H.P. =  $746.4 \frac{\text{J}}{\text{s}}$ ) (12)

**SECTION - B**There are **FOUR** questions in this Section. Answer any **THREE**.

5. (a) What are the conditions necessary for observing interference fringes? Describe Young's double slit experiment and derive an expression of fringe width at a point on the screen. (22  $\frac{2}{3}$ )
- (b) Using the principle of optical reversibility discuss how Stokes investigated the phase changes of light due to reflection at an interface between two media. (16)
- (c) Newton's rings are observed in reflected light of wavelength  $5900 \text{ \AA}$ . The diameter of the  $10^{\text{th}}$  ring is found to be  $0.50 \text{ cm}$ . Find the radius of curvature of the lens. (08)
6. (a) What do you understand by diffraction of light? What is Fraunhofer diffraction and how does it differ from Fresnel diffraction? (12)
- (b) Derive the expression of intensity due to Fraunhofer diffraction produced by double slits. (25  $\frac{2}{3}$ )
- (c) Deduce the missing orders for a double-slit Fraunhofer diffraction pattern if each slit has equal width of  $0.16 \text{ mm}$  and they are  $0.8 \text{ mm}$  apart. (09)
7. (a) Define Wigner-Seitz primitive cell. (05)
- (b) What is space lattice? Write down the unit cell characteristics of the seven crystal systems with fourteen Bravais lattices. (13)
- (c) Draw the unit cell of diamond crystal and find the number of atoms per cell. (08)
- (d) Show that for an ideal hexagonal close packed (hcp) structure,  $\frac{c}{a} = 1.633$ , where the symbols have their usual meaning. Using this relation estimate the packing fraction of hcp crystal. (20  $\frac{2}{3}$ )
8. (a) Define Miller indices and explain the method of calculating them. (07)
- (b) Draw the (100), (011), (101) and (0 $\bar{1}$ 0) planes for a simple cubic structure. (08)
- (c) Derive the expression of Bragg's condition for X-ray diffraction. What is the use of this condition in crystallography? (13  $\frac{2}{3}$ )
- (d) Explain metal, semiconductor and dielectrics by means of band theory. (10)
- (e) Determine the first Order diffraction angle through which an X-ray of wavelength  $0.44 \text{ \AA}$  is reflected from (102) plane of a simple cubic crystal having lattice constant  $2.42 \text{ \AA}$ . (8)

**SECTION – A**

There are **FOUR** questions in this Section. Answer any **THREE**.  
Symbols have their usual meaning.

1. (a) Sketch the graph of function  $f(x) = \begin{cases} x^2 + 1 & \text{for } x < 0 \\ 1 & \text{for } 0 \leq x < 1 \\ \frac{1}{x} & \text{for } x \geq 1 \end{cases}$  (25)

and discuss continuity and differentiability of  $f(x)$  at  $x = 0$  and at  $x = 1$ .

(b) Test whether the limit  $\lim_{x \rightarrow \pi/2} \frac{e^{\tan x} - 1}{e^{\tan x} + 1}$  exists. (10)

If possible find the value of the limit.

2. (a) If  $y = e^{m \cos^{-1} x}$  then show that  $(1 - x^2) y_{n+2} - (2n + 1)xy_{n+1} - (n^2 + m^2)y_n = 0$  and find the value of  $y_n$  at  $x = 0$ . (20)

(b) If the normal to the curve  $x^{2/3} + y^{2/3} = a^{2/3}$  makes an angle  $\phi$  with the axis of  $x$ , show that its equation is  $y \cos \phi - x \sin \phi = a \cos 2\phi$ . (15)

3. (a) State and prove Rolle's theorem and verify it for the function  $f(x) = x^3 - x^2 - 4x + 4$  in the interval  $(-2, 2)$ . (17)

(b) If  $u = \tan^{-1} \frac{x^3 + y^3}{x - y}$ ; then show that  $x \frac{\partial u}{\partial x} + y \frac{\partial u}{\partial y} = \sin 2u$  (18)

and evaluate  $x^2 u_{xx} + 2xy u_{xy} + y^2 u_{yy}$ .

4. (a) Find the maximum and minimum values of  $f(x) = x^4 - 8x^3 + 22x^2 - 24x + 5$ . Sketch the graph of  $f(x)$ . (13)

(b) Find the radius of curvature and equation of the circle of curvature at the point  $(3, 1)$  on the curve  $y = x^2 - 6x + 10$ . (12)

(c) Find the asymptotes of the curve  $x^3 - 2y^3 + xy(2x - y) + y(x - y) + 1 = 0$ . (10)

**MATH 141****SECTION - B**

There are **FOUR** questions in this Section. Answer any **THREE**.

5. (a) Simplify the equation (12)  
 $5x^2 - 2xy + 5y^2 + 2x - 10y - 7 = 0$   
 by suitable translation and rotation of axes.
- (b) Find the value of  $k$  so that the lines which joint the origin to the points of intersection of the line  $y - x - k = 0$  and the curve  $x^2 + y^2 + 4x - 6y - 36 = 0$  may be at right angles. (8)
- (c) Show that the distance from the origin to the orthocentre of the triangle formed by the straight line  $\frac{x}{\alpha} + \frac{y}{\beta} = 1$  and  $ax^2 + 2hxy + by^2 = 0$  is  $\frac{(a+b)\alpha\beta\sqrt{\alpha^2 + \beta^2}}{a\alpha^2 + 2h\alpha\beta + b\beta^2}$ . (15)
6. (a) Find the radical axis of the co-axial system of circles whose limiting points are  $(-1, 2)$  and  $(2, 3)$ . (10)
- (b) Find the locus of the centre of the circle which cuts each of the circles  $x^2 + y^2 + 3x - 5y - 7 = 0$  and  $x^2 + y^2 - x + y + 2 = 0$  orthogonally. (10)
- (c) Prove that the two circles each of which passes through  $(0, k)$  and  $(0, -k)$  and touch the line  $y = mx + b$  will cut orthogonally, if  $b^2 = k^2(2 + m^2)$ . (15)
7. (a) Find the locus of a point which is such that the three normals to the parabola  $y^2 = 4ax$  through it cut the axis in points whose distances from the vertex are in arithmetic progression (A. P). (17)
- (b) If  $P$  and  $D$  be the ends of a pair of conjugate diameters of an ellipse, find the locus of (18)  
 (i) the mid-point of  $PD$  and  
 (ii) the point of intersection of tangents at  $P$  and  $D$ .
8. (a) Find the locus of the foot of the perpendicular from the centre upon any normal to the hyperbola  $\frac{x^2}{a^2} - \frac{y^2}{b^2} = 1$  (15)
- (b) If one of the straight lines given by  $ax^2 + 2hxy + by^2 = 0$  coincide with one of the lines given by  $a_1x^2 + 2h_1xy + b_1y^2 = 0$  and the other lines represented by them are perpendicular, then prove that  $\frac{ha_1b_1}{b_1 - a_1} = \frac{h_1ab}{b - a} = \frac{1}{2}\sqrt{-aa_1bb_1}$ . (20)

-----

**SECTION - A**

There are **FOUR** questions in this section. Answer any **THREE**.

1. (a) Find the equivalent resistance ( $R_{eq}$ ) between point A and B for the network of Fig. for Q. No. 1(a). (17)

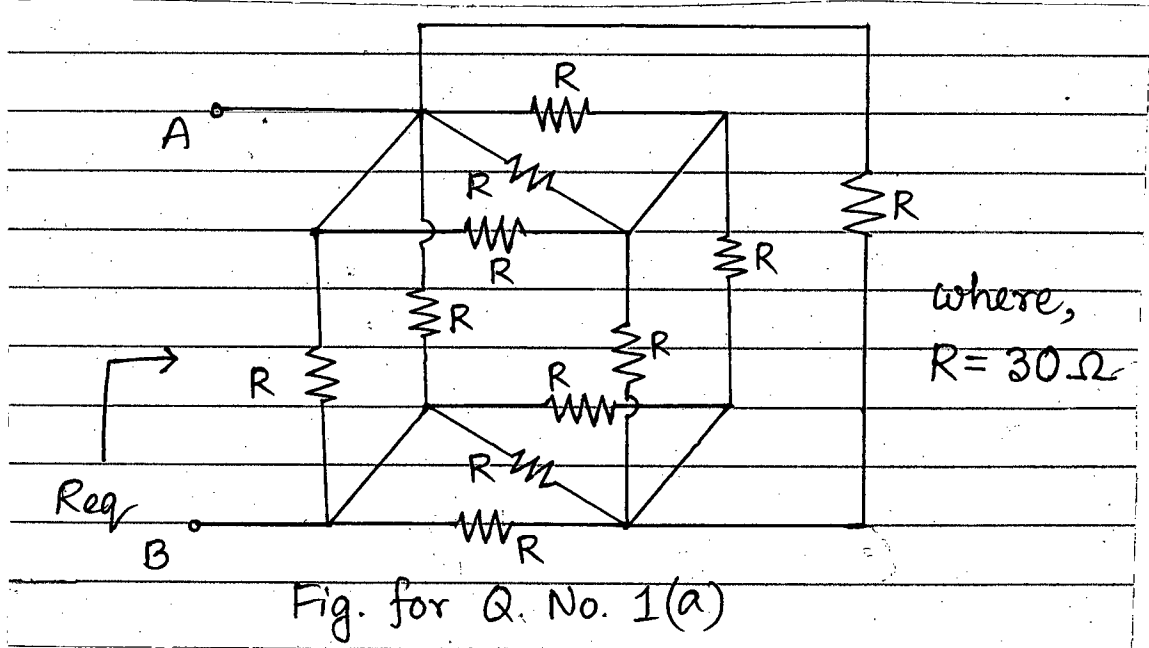

- (b) In the circuit of Fig. for Q. No. 1(b), the current through the  $R_1$  resistor is 1A. Find source voltage  $V_g$ . (18)

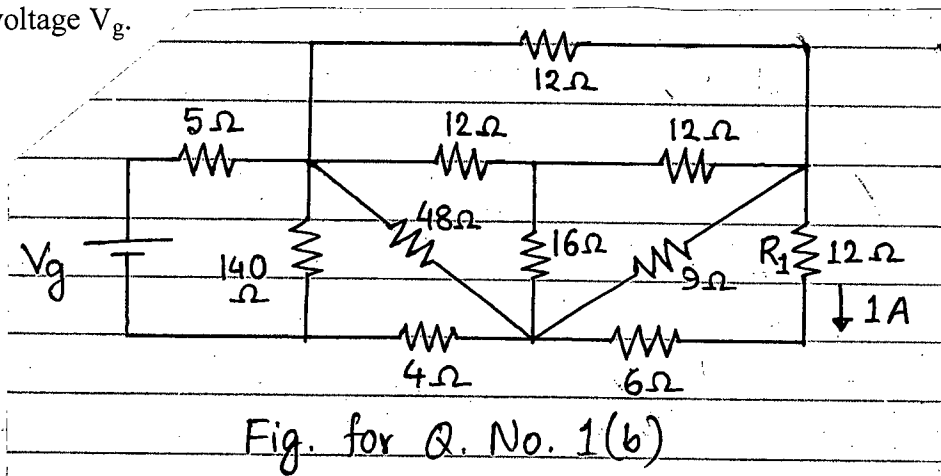

2. (a) Using source transformation find  $i_0$  in the circuit shown in Fig. for Q. No. 2(a). (17)

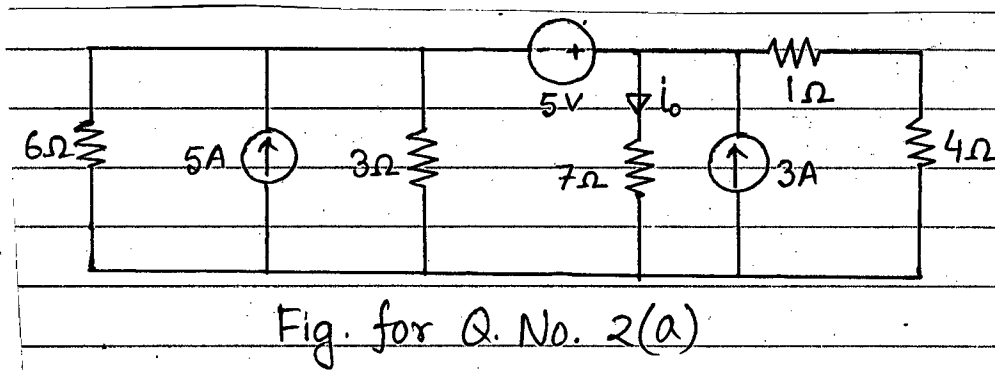



**EEE 163**

**Contd ... Q. No. 2**

(b) Find the current  $I_0$  for the circuit shown in Fig. for Q. No. 2(b) using superposition theorem. (18)

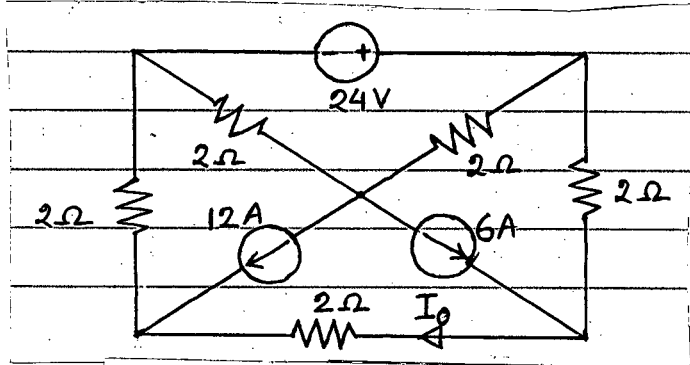

Fig. for Q. No. 2(b)

3. (a) Using mesh analysis, find the value of  $V_0$  in the circuit shown in Fig. for Q. No. 3(a). (17)

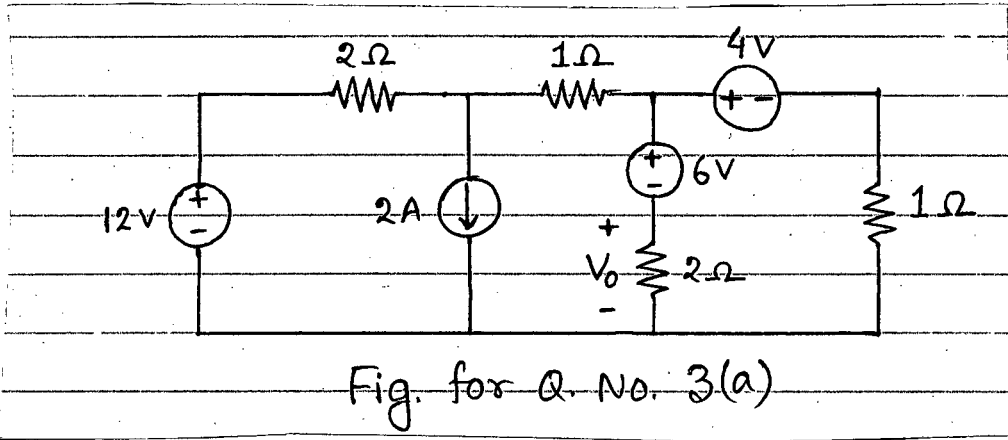

Fig. for Q. No. 3(a)

(b) Using nodal analysis, find the voltage drop  $V$  across the  $4\Omega$  resistance for the circuit shown in Fig. for Q. No. 3(b). (18)

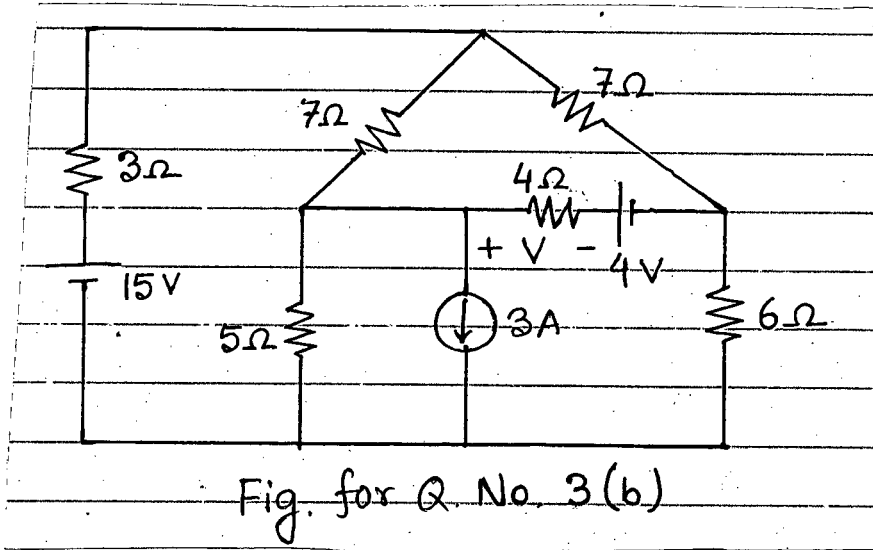

Fig. for Q. No. 3(b)

4. (a) For the circuit shown in Fig. for Q. No. 4(a): (18)

- (i) Find the Thevenin's equivalent between terminal A and B.
- (ii) For maximum power transfer to  $R_L$ , find the value of  $R_L$ .

**EEE 163**

**Contd ... Q. No. 4**

(iii) Calculate the maximum power that can be delivered to  $R_L$  of the circuit of Fig. for Q. No. 4(a).

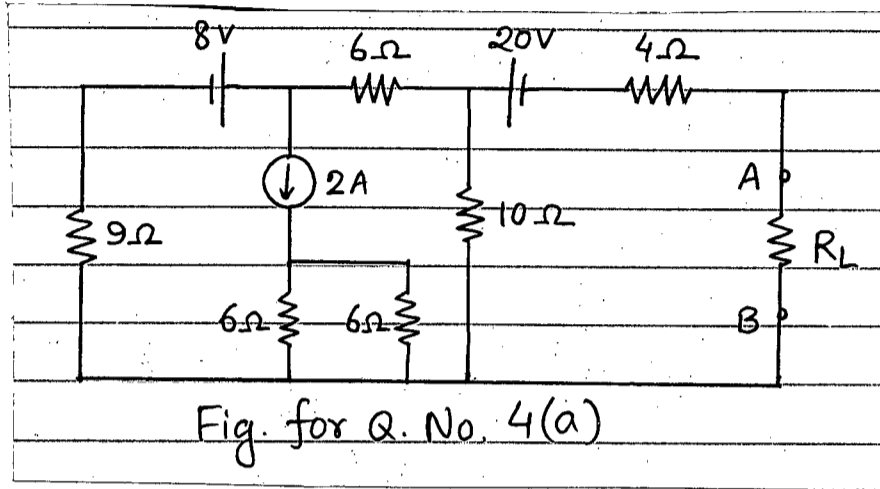

(b) Using Newton's equivalent circuit, find the value of  $I_0$  in the circuit shown in Fig. for Q. No. 4(b).

(17)

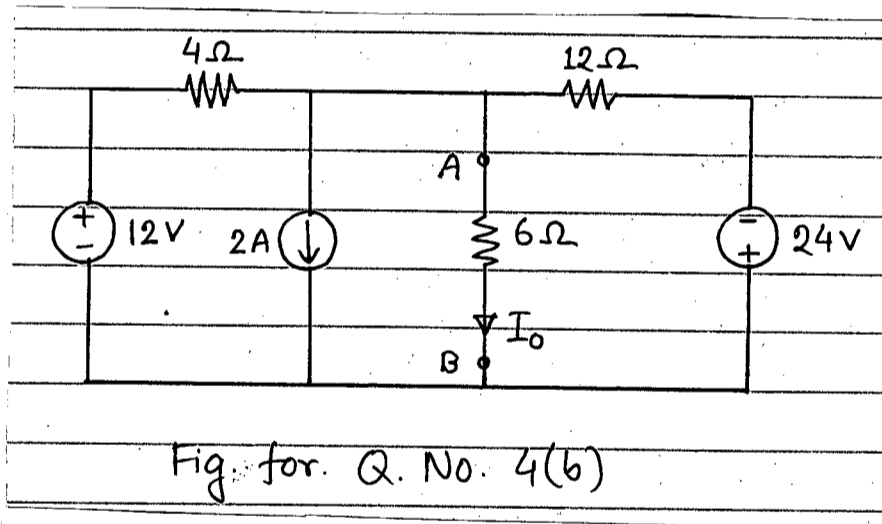

**SECTION - B**

There are **FOUR** questions in this section. Answer any **THREE**.

5. (a) Assume that the current  $i(t) = I_m \sin \omega t$  flows through a series RL branch. Derive the expressions for applied voltage, impedance, instantaneous power, real power and reactive power. Also draw the wave shape for power.

(20)

(b) A voltage  $v(t) = 141.4 \cos (100t)$  V is applied to a series circuit and the resulting current is found to be  $i(t) = 0.707 \cos (100t - 53.13^\circ)$  A. One element of this series combination is an inductance of 1800 mH. Determine the magnitude of other series elements present.

(15)

**EEE 163**

6. (a) Find the real power dissipated in the circuit of the Fig. for Q. 6(a). The waveform of the  $i(t)$  is also given in the Fig. for Q. 6(a). (20)

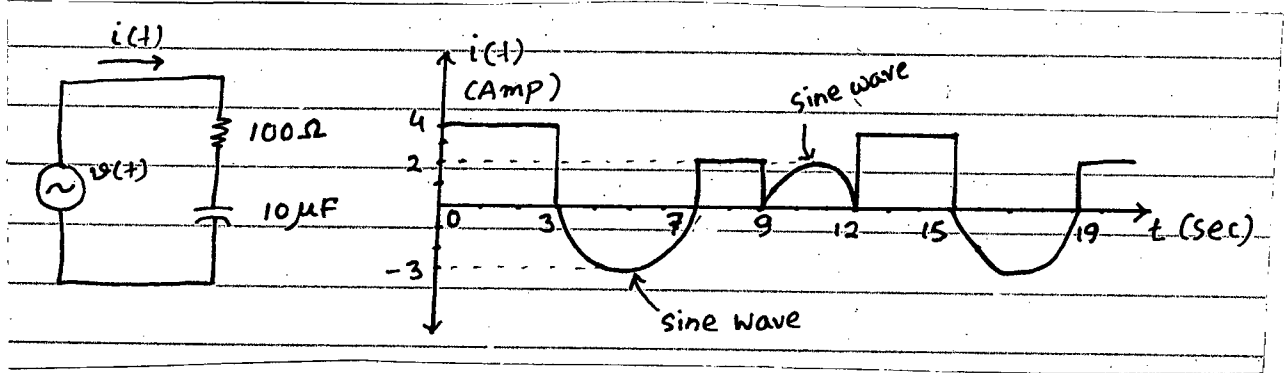

Figure for Q. 6(a)

- (b) Draw the phasor diagram indicating  $V_{C1}$ ,  $V_{L2}$ ,  $I$ ,  $I_1$ ,  $I_2$  and  $V_{R2}$  as shown in the circuit of the Fig. for Q. 6(b) assuming  $V_{AB}$  as reference. (15)

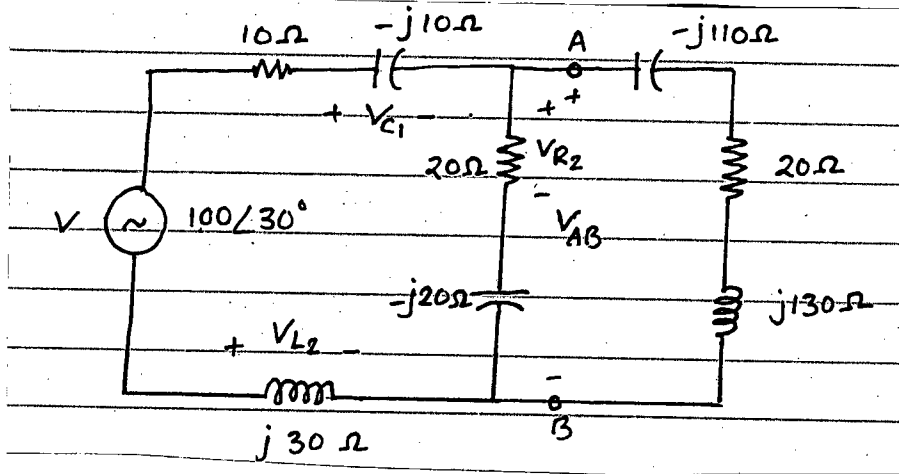

Figure for Q. 6(b)

7. (a) Find  $z_{eq}$  of the circuit shown in the Fig. for Q. 7(a). (15)

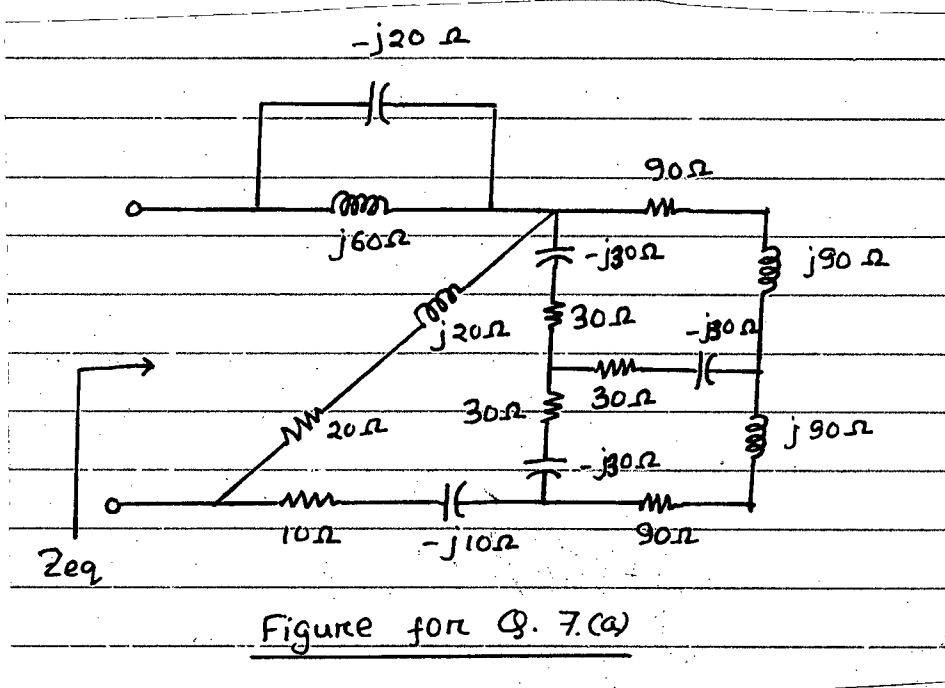
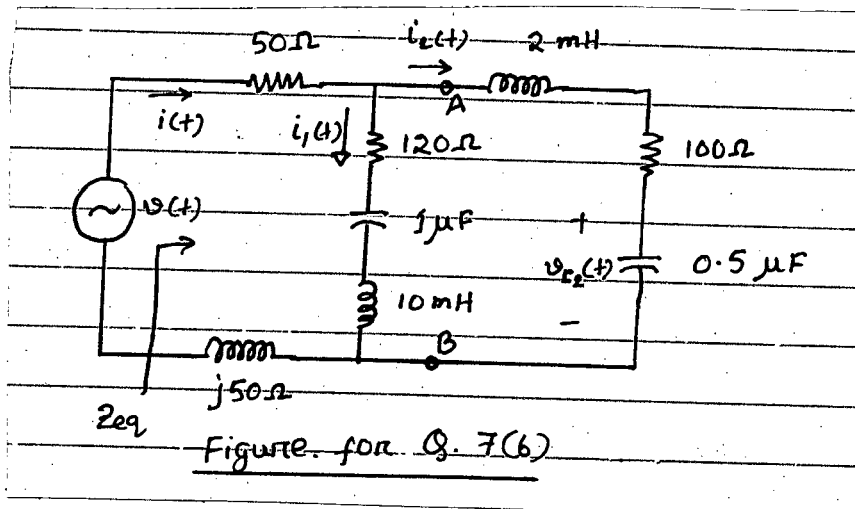

Figure for Q. 7(a)

**EEE 163**

**Contd ... Q. No. 7**

(b) Assume that a voltage  $v(t) = 5 \sin(4000\pi t + 15^\circ)$  V is applied in the circuit shown in the Fig. for Q. 7(b). Find (i) expression of  $i_1(t)$ , (ii) expression of  $V_{C2}(t)$ , (iii)  $z_{eq}$ , (iv) VA, (v) power factor, (vi) real power consumed in AB branch. (20)



8. (a) Define – MMF, Magnetic flux density and permeability. (9)  
 (b) State Ampere's circuit law. (6)  
 (c) Determine the current I required to establish a flux of  $\phi_2 = 2 \times 10^{-4}$  wb in the section of the core indicated in the Fig. for Q. 8(c). (20)

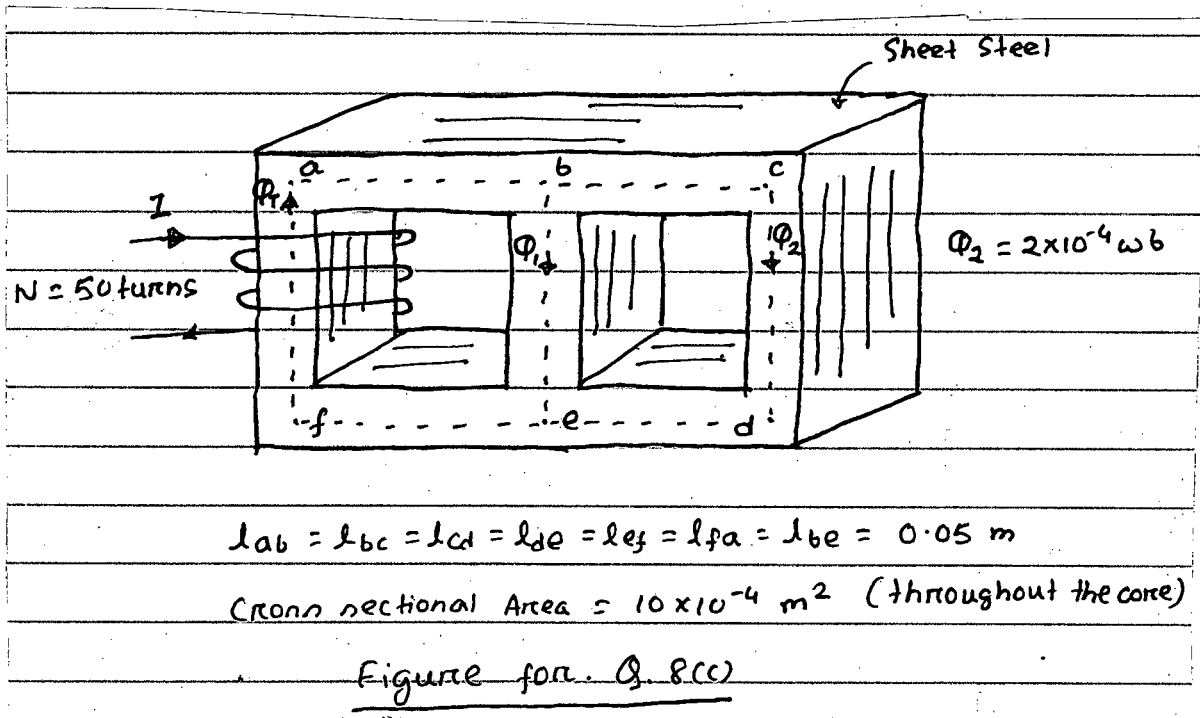

B-H curve :

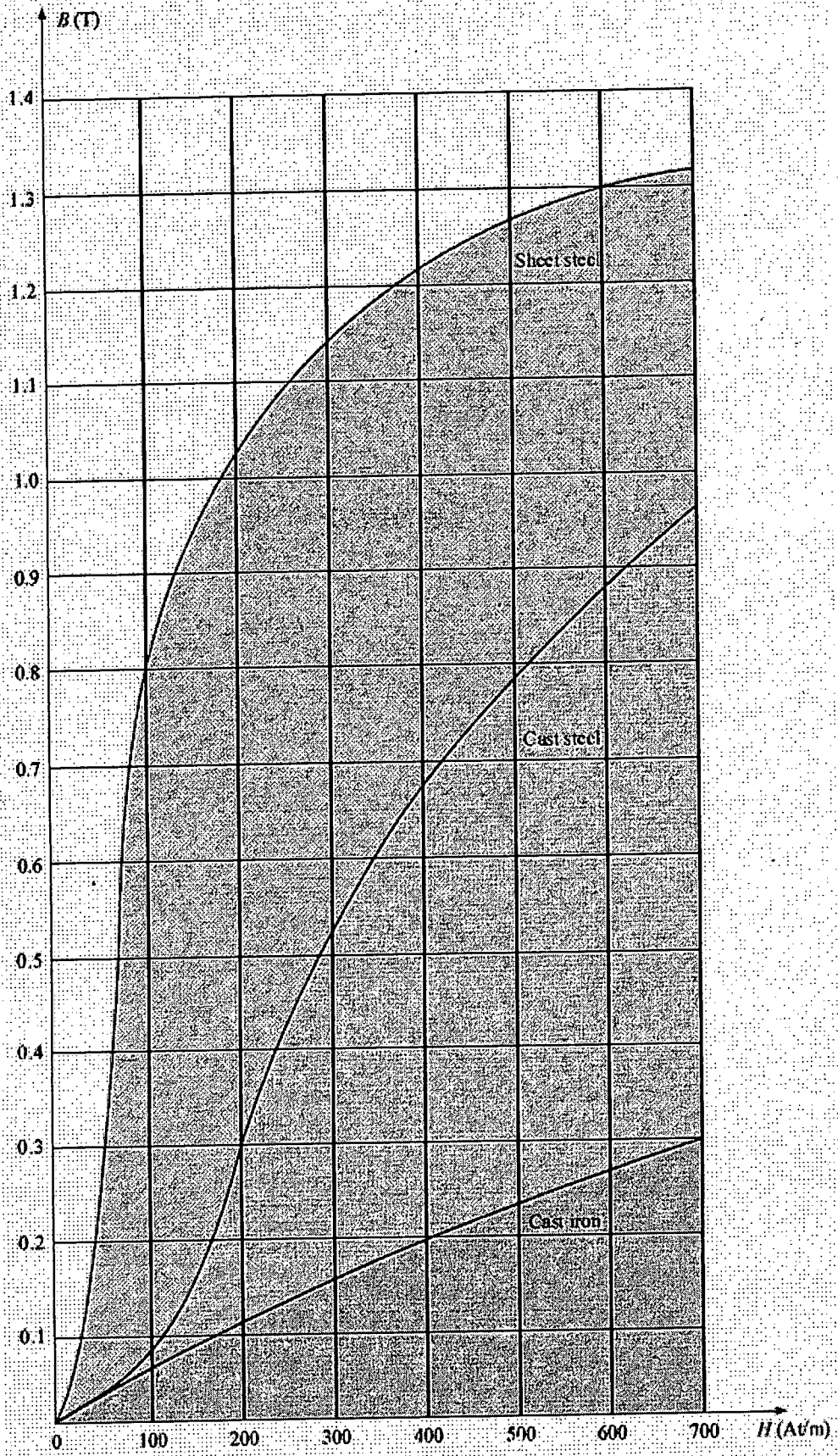

B-H curve for  $\phi$ . 8(c)