

BANGLADESH UNIVERSITY OF ENGINEERING AND TECHNOLOGY, DHAKA

L-2/T-1 B. Sc. Engineering Examinations 2010-2011

Sub : **MATH 241** (Complex Variable and Statistics)

Full Marks : 210

Time : 3 Hours

The figures in the margin indicate full marks.

Symbols used have their usual meanings.

USE SEPARATE SCRIPTS FOR EACH SECTION

SECTION – AThere are **FOUR** questions in this section. Answer any **THREE**.

1. (a) (i) Determine and graph the locii represented by $|z|^2 + 3\text{Re}(z^2) \leq 4$. (5)

- (ii) Find whether $f(z)$ is continuous at the origin, where (5)

$$f(z) = \begin{cases} \frac{\text{Re}(z^2)}{|z^2|}; & z \neq 0 \\ 0 & ; z = 0 \end{cases}$$

- (iii) Show that the function (5)

$$f(z) = \frac{1}{z^4}; \quad z \neq 0$$

is an analytic function.

- (b) Show that the function $g(z) = \sqrt{r}e^{i\theta/2}$, where $(z = re^{i\theta})$, $r > 0$, $-\pi < \theta < \pi$, is analytic in its domain of definition with derivative $g'(z) = \frac{1}{2g(z)}$. Then discuss the analyticity of the

composite function $G(z) = g(4z - 4 + i)$. (5)

- (c) Show that the function $v(x, y) = -\sin x \sinh y$ is a harmonic function and find a corresponding analytic function $f(z) = u(x, y) + iv(x, y)$. (5)

- (d) (i) Show that $\cosh^{-1} z = \log \left[z + (z^2 - 1)^{1/2} \right]$. (5+5=10)

- (ii) Solve the equation $\sin z = 2$ for z by equating real and imaginary parts.

2. (a) Show that (5+5=10)

(i) $\log(-1 + \sqrt{3}i)^2 = 2\log(-1 + \sqrt{3}i)$ where $\log z = \ln r + i\theta$; ($r > 0, 0 < \theta < 2\pi$)

(ii) $\log(-1 + \sqrt{3}i) \neq 2\log(-1 + \sqrt{3}i)$ where $\log z = \ln r + i\theta$; ($r > 0, -\pi < \theta < \pi$)

- (b) Show that the line $2y = x$ is mapped onto a circle under the bilinear transformation

$$\omega = \frac{iz + 3}{5z + i}$$

Find the centre and radius of the image circle. Find also the point in the z -

plane which is mapped onto the centre of the circle. (10)

= 2 =

MATH 241(CSE)

Contd ... Q. No. 2

(c) Find the image of the closed triangular region formed by the lines $y = \pm x$ and $x = 1$ under the transformation $\omega = z^2$. Draw a graph of the triangular region and its image. **(10)**

(d) Without evaluating the integral find an upper bound for the integral **(5)**

$$\left| \int_c (e^z - \bar{z}) dz \right|$$

Where c is the boundary of the triangle with vertices at the points $0, 6i$ and -8 .

3. (a) Evaluate the integral $\int_c iz^2 dz$ where the contour c is the portion of the ellipse $\frac{x^2}{16} + y^2 = 1$ in the first quadrant. **(10)**

(b) Represent $f(z)$ in terms of partial fractions and then use Cauchy's integral theorem to evaluate $\int_c f(z) dz$ where $f(z) = \frac{z^2 - z + 2}{z^3 - 2z^2}$ and c is the boundary of the rectangle with vertices $3 \pm i, -1 \pm i$, taken counterclockwise. **(8)**

(c) Expand $f(z) = \frac{2z^2 + 9z + 5}{z^3 + z^2 - 8z - 12}$ in a Taylor series in powers of $(z - 1)$ and state the region of convergence. **(10)**

(d) Find a Laurent series expansion of $f(z) = \frac{1}{(z+1)(z-3i)}$ in powers of $(z + 1)$ and state the region in which the expansion is valid. **(7)**

4. (a) Evaluate the following integrals: **(5×3=15)**

(i) $\int_c \frac{\cos z}{z^{2n}} dz$

(ii) $\int_c e^z \sec \pi z dz$

(iii) $\int_c e^z \cot \frac{z}{4} dz$; Where c is the unit circle taken in positive sense.

(b) Use Residue theorem to evaluate the following integrals: **(5+10=15)**

(i) $\int_c \frac{dz}{(z^3 - 1)^2}$

(ii) $\int_c \frac{\text{Log} z}{(z^2 + 1)^2} dz$

Where c is the circle $|z| = 2$ taken counterclockwise.

(c) Evaluate $\int_{\Gamma} \frac{\cos z}{4 + z^2} dz$; where Γ is the square of side length 3 and sides parallel to the axes centered at $-2i$. **(5)**

MATH 241(CSE)

SECTION – B

There are **FOUR** questions in this section. Answer any **THREE**.

5. Evaluate the following integrals by using contour integration (20+15)

(a) $\int_{-\infty}^{\infty} \frac{\cos x \, dx}{(x^2 + a^2)(x^2 + b^2)}$ $a > 0, b > 0$ (b) $\int_0^{\infty} \frac{dx}{(1+x^2)^2}$

6. (a) Find the mean deviation from the mean and standard deviation of the arithmetic progression $a, a + d, a + 2d, \dots, a + 2nd$ and verify that the latter is greater than the former. (17)

(b) Calculate the first four moments of the following distribution about the mean and hence find β_1 and β_2 . Also comment on the shape of the distribution using above results and Karl-Pearson and Bowley's coefficient of skewness. (18)

x:	0	1	2	3	4	5	6	7	8
y:	1	8	28	56	70	56	28	8	1

7. (a) Obtain the regression lines of Y on X and X on Y from the following data. Also obtain the estimate of X for Y = 90. (17)

X:	75	80	93	65	87	71	98	68
Y:	82	78	86	72	91	80	95	72

(b) Two dice are tossed. Find the probability of getting an even number on the first die or a total of eight. (9)

(c) A box contains 6 red, 4 white and 5 black balls, A person draws 4 balls from the box at random. Find the probability that among the balls drawn there is at least one ball of each colour. (9)

8. (a) The probability that a patient recovers from a rare blood disease is 0.4. If 15 people are known to have contacted this disease, what is the probability that (17)

- (i) at least 10 survive
- (ii) from 3 to 8 survive
- (iii) exactly 5 survive ?

(b) Fit a Poisson distribution to the following data: (18)

Number of mistakes per page	0	1	2	3	4	Total
Number of pages	109	65	22	3	1	200

SECTION – A

There are **FOUR** questions in this Section. Answer any **THREE**.

All the questions in this section are related to C++ programming.

1. (a) Define virtual function. Why is virtual function used in C++ Programming? (5)
 (b) The constructor of class "coord" allocates dynamic memory and the destructor frees the memory. When an object of the class is used as a call by value argument to a function, then the original value in the dynamic memory is to be damaged. Why? Explain with example. (15)
 With appropriate examples, explain two methods to solve the above mentioned problem.
 (c) What is a friend function? How does a friend function differ from a member of a class? Explain the reasons of using friend function in C++ programming. (15)

2. (a) Differentiate between real-time polymorphism and run-time polymorphism with appropriate examples. (10)
 (b) With appropriate example explain why using a default argument is related to constructor overloading. (5+3)
 What is wrong with the following function prototype?

```
char *f(char *p, int x = 0, char *q);
```

 (c) Explain some ways that ambiguity can be introduced when you are overloading functions. (10)
 Why are the following two overloaded functions inherently ambiguous?

```
int f(int a);  
int f(int &a);
```

 (d) Create a function called **reverse()** that takes two parameters. The first parameter, called **str**, is a pointer to a string that will be reversed upon return from the function. The second parameter is called **count**, and it specifies how many characters to **str** to reverse. Give count a default value that, when present, tells **reverse()** to reverse the entire string. (7)

3. (a) Write a function called **neg()** that reverses the sign of its integer parameter. Write the function in two ways- first by using a pointer parameter and then by using a reference parameter. Include a short program to demonstrate their operation. (10)

CSE 201

Contd ... Q. No. 3

(b) Consider the following declarations:

(15)

```
class coord {
    int x, y;
public:
    coord(int i = 0, int j = 0) {x = i; y = j;}
    void getxy(int &i, int &j) {i = x; j = y;}
    coord operator + (coord ob2);
    coord operator + (int i);
    coord operator ++ ();
    bool operator == (coord ob2);
    coord operator = (coord ob2);
};
coord o1(2, 4), o2, o3(3, 1);
```

Explain what happens when the following statements are executed:

- (i) `(o1+o2).getxy(p, q);`
- (ii) `o3 = o3 + o2 + o1;`

Why the statement "`o3 = 100 + o1;`" will not be executed? Write a function so that this statement can be executed without error.

(c) Overload the <and> operators relative to the "coord" class defined in 3(b).

(10)

4. (a) Define an independent reference. Explain with example how a returning reference can allow a function to be used on the left side of an assignment.

(7)

(b) What happens when a public member is inherited as public? What happens when a public member is inherited as private or protected?

(8)

(c) Create a program that prints the natural logarithm and 10-base logarithm of the number from 2 to 100. Format the table so the numbers are right justified within a field width of 10, using a precision of five decimal places.

(10)

(d) Create an inserter and an extractor for this class:

(10)

```
class pwr{
    int base;
    int exponent;
    double result; //base to the exponent power
public:
    pwr(int b, int e);
};
pwr::pwr (int b, int e){
    base = b;
    exponent = e;
    result = 1;
    for(; e; e--) result = result * base;
}
```

CSE 201

SECTION – B

There are **FOUR** questions in this Section. Answer any **THREE**.

5. (a) What is the use of an *import* declaration in a Java program? What is the restriction associated with such a declaration? Mention two cases where *import* declarations are not required. (6)
- (b) Differentiate between *primitive types* and *reference types* in Java. (5)
- (c) Write down two differences between Java reference and C++ pointer. (4)
- (d) What do you understand by *short-circuit evaluation* related to the operators in Java? Which operators show this type of behavior? Explain with an example. (8)
- (e) Explain two usages of the keyword *static*. (8)
- (f) How can we create a user-defined exception type? Give an example. (4)
6. (a) What is the proper signature for *main* method in Java? Explain every component of the signature. What happens if *main* method is not written with proper signature? (6+2)
- (b) Create a jagged array having three (3) rows with two (2), five (5), and three (3) elements respectively. All elements are initialized to default values. You cannot use initializer lists. Write down the code snippet to print the contents of this array using Java's special *for-each* statement only. You cannot use any other looping construct. (4+4)
- (c) What is the role of *Garbage Collector* in Java? Consider the following code snippet: (2+8)
- ```
String s1 = "It";
String s2 = "was";
String s3 = s1 + " " + s2;
s2 += " roses, ";
s3 = s3 + s2 + "roses all the way.";
System.out.println(s3);
```
- (i) What will be the output of this code snippet?
- (ii) How many *String* objects will be created in this code snippet? Show the contents of each *String* object individually and state which of them will be marked for garbage collection.
- (d) Explain three different usages of the keyword *finally* with examples. (9)
7. (a) Do you agree or disagree with the statement – "**All interfaces are abstract classes but, not all abstract classes are interfaces**"? – Give valid reasoning in support of your opinion. (4)
- (b) In which situation **JVM** throws a *ClassCastException*? Explain with an example. How can we avoid *ClassCastException*? (5+2)

**CSE 201**

**Contd ... Q. No. 7**

(c) What is the difference between Java applications and applets? Write down the Java code to create a simple applet which draws the string "*Welcome to Java*". What code we need to write to embed this applet in an HTML document? (2+6)

(d) Consider the following class definition (7)

```
class Student {
 private int id;
 private String name;
 private double cgpa;

 public Student (int i, String n, double c){
 id = i; name = n; cgpa = c;
 }
}
```

Assume that *name* of a *Student* object will never be *null*. Now override the *public boolean equals (Object obj)* method in class *Student* so that we can have the following scenario:

```
Student s1 = new Student(1, "Mr. A", 3.95);
Student s2 = new Student(2, "Mr. B", 3.95);
Student s3 = new Student(3, "Mr. A", 3.95);
Student s4 = new Student(4, "Mr. A", 4.00);
```

```
boolean b1 = s1.equals(s2); // sets b1 to false
boolean b2 = s1.equals(s3); // sets b2 to true
boolean b3 = s1.equals(s4); // sets b3 to false
```

(e) Explain the roles of the entities involved in Java's *Delegation Event Handling* model. (9)

8. (a) Write down the syntax used for Java's '*catch or declare*' strategy of exception handling. (7)

(b) What are the differences between *static nested class* and *inner class*? (5)

(c) What is an *adapter* class? What are the advantages and disadvantages of using such classes? (6)

(d) Explain *Object Serialization-Deserialization* with an example. (8)

(e) Give an example of a multithreaded Java program using *Runnable* interface. You must ensure that the *main* thread terminates last. Mention two different ways to achieve synchronization among threads in Java. (6+3)

-----

**SECTION – A**

There are **FOUR** questions in this Section. Answer any **THREE**.

1. (a) Write down an algorithm for searching an element  $z$  in an unsorted array  $A$  containing  $n$  elements. Analyze best case, average case and worst case complexity of successful and unsuccessful searches. (15)  
 (b) Carry out similar analyses if the array is sorted. Apply both the versions of binary search algorithm. Simulate binary search algorithm on the array 2, 3, 6, 8, 10, 12, 14, 16, 17, 23, 26 when 2, 26 and 15 are searched showing values of *low*, *mid*, *high* and *found* in a table. (20)
2. (a) Write down two algorithms for verifying whether an integer corresponds to a leap year or not. Compute the average number of comparisons required by the algorithm. (15)  
 (b) Discuss Carlsson's variant of heap sort, and deduce its complexity. Deduce complexity of the two algorithms for heap construction. (20)
3. (a) Sort the array 12, 2, 14, 3, 16, 6, 17, 8, 23, 10, 26 using heapsort showing values in the right of the nodes. (15)  
 (b) Write down the Quick sort algorithm. Simulate Quicksort algorithm on the array of Question 3(A) showing in detail how partition routine works. (20)
4. (a) Write down a linear time algorithm for finding the maximum sum of consecutive subsequence. Given an array 12, -2, 14, 3, -16, 6, 17, -8, 23, -10, 26, 12, 2, -14, 3, 16, 6, 17, 8, -23, 10, -26 find the maximum sum of consecutive subsequence mentioning the values of suffixmax and maxsum. (15)  
 (b) Deduce the recurrence relation followed by an optimal binary search tree. Given the frequencies of a series of keywords (begin, continue, do end, for) = (2, 7, 3, 8, 4) and (9, 2, 4, 6, 1, 5) as frequencies of unsuccessful searches in order to construct an optimal binary search tree. (20)

**SECTION – B**

There are **FOUR** questions in this Section. Answer any **THREE**.

5. (a) Following pseudocode represents the **Enqueue** and **Dequeue** methods of implementing a *Queue* using two Stacks, named *inputStack* and *outputStack*. (20)



**CSE 203**

Contd ... Q. No. 5(a)

**Enqueue(x)**

inputStack.push(x)

**Dequeue**

if outputStack.size = 0 then

    while inputStack.size ≠ 0 do

        outputStack.push(inputStack.pop())

    return outputStack.pop()

Show that, the amortized cost of any sequence of **n** Enqueue and Dequeue operations takes a total **O(n)** time using accounting method.

(b) Using closed hashing, with double hashing to resolve collisions, insert the keys 28, 51, 17, 23, 30, 20, 18, 85, 52, 26 into a hash table of thirteen slots using following hash functions:

$$h1(k) = k \text{ mod } 13.$$

$$h2(k) = (\text{Rev}(k + 1) \text{ mod } 11)$$

Here, function Rev(k) reverses the decimal digits of k, for example, Rev(37) = 73

(15)

6. (a) Prove that, one restructuring of the following AVL tree using double rotation restores the height-balance property globally. Given, z is the first node violating height-balance property of the AVL tree from the bottom. The figure is not drawn to scale.

(15)

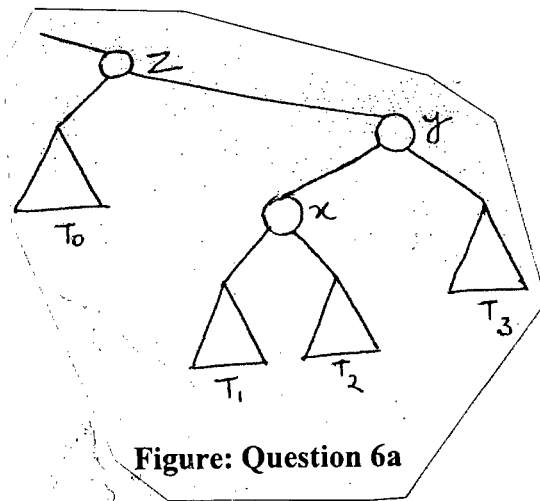

(b) Show the steps for sorting following words using Least Significant Digit Radix Sort:

heir, ice, badge, keen, paint, mail, dam

(10)

(c) Following table shows the keys and consecutive numbers of the heads found in toss while inserting the keys in a probabilistic Skiplist:

(10)

|                   |    |    |     |     |     |     |     |     |     |
|-------------------|----|----|-----|-----|-----|-----|-----|-----|-----|
| Key               | 55 | 32 | 132 | 200 | 861 | 823 | 937 | 916 | 524 |
| Consecutive heads | 2  | 3  | 1   | 4   | 2   | 1   | 1   | 3   | 4   |

Draw the final Skiplist.

CSE 203

7. (a) Do a topological sort of the following graph:

(13)

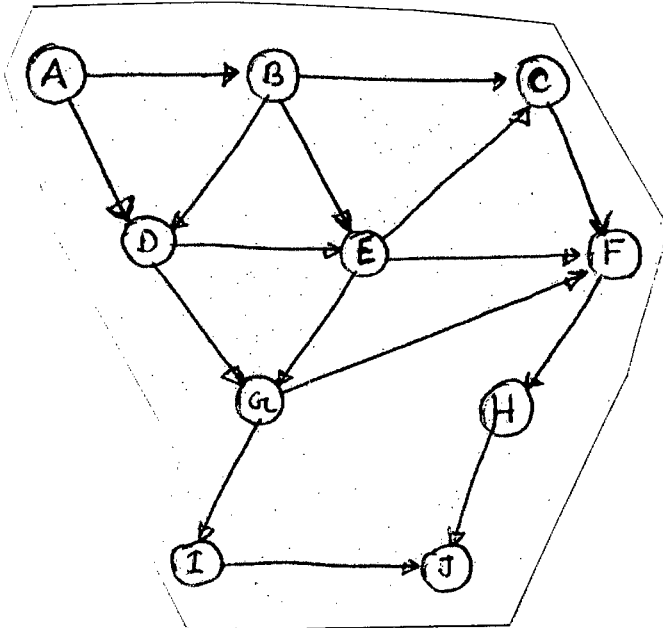

Figure: Question 7a

(b) Consider following (2, 4) tree

(12)

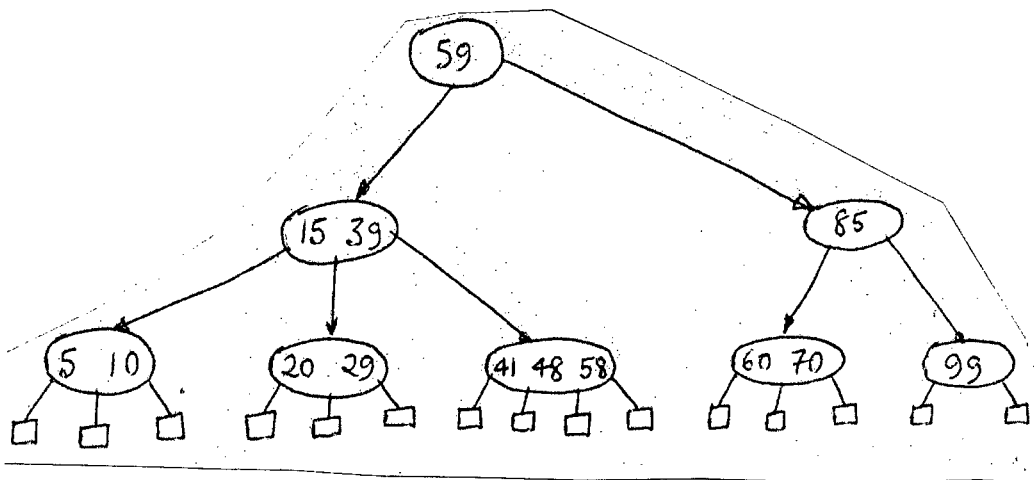

Figure: Question 7b

Draw the tree after each of the following operations:

- i. Insert 53
- ii. Delete 99
- iii. Delete 70

(c) Show that, expected running time of searching in a probabilistic skip list is  $O(\lg n)$ .

(10)

8. (a) Starting with a singleton set  $S_i$  for each item  $i$ , where  $1 \leq i \leq 10$ ,

(12)

show the forests of up-trees that results in after each of the following operations using union by rank and path compression heuristics.

**CSE 203**

Contd ... Q. No. 8(a)

$A \leftarrow \text{Union}(S1, S2)$

$B \leftarrow \text{Union}(A, S3)$

$C \leftarrow \text{Union}(S4, B)$

$D \leftarrow \text{Union}(S5, S6)$

$E \leftarrow \text{Union}(D, S7)$

$F \leftarrow \text{Union}(C, E)$

$\text{Find}(7)$

(b) A vector, V is implemented by the means of an expandable array. When overflow occurs while inserting an element a new array of double capacity is allocated and all the previously inserted elements are copied to the newly allocated array along with the insertion of the new element. Show that, the total time to perform a series of n insertion operations in empty v with the initial size of 1 is  $O(n)$  using aggregate analysis. **(13)**

(c) Prove that, a multi-way search tree with n keys has  $n + 1$  external nodes. **(10)**

-----

**SECTION – A**

There are **FOUR** questions in this Section. Answer any **THREE**.

1. (a) Write down the procedure for subtraction of two positive numbers (M-N), both of base r, with the (r-1)'s complement. Prove its correctness. (7+7=14)

- (b) Perform the following subtraction using both 1's complement and 2's complement. (5+5=10)

$$(1001)_2 - (10010)_2$$

- (c) Find the complement of the function by taking its dual. (4)

$$f = x'(yz' + y'z)$$

- (d) Simplify the Boolean function using algebraic manipulation and then implement the simplified function with only AND and NOT gates. (7)

$$f = x' y' + xz + y'z$$

2. (a) Express the following Boolean function in a sum of minterms and a product of maxterms. (8)

$$f = (xy + z) (y + xz)$$

- (b) Prove or disprove that the NAND operator is not associative and is not distributive over NOR operator. (5+6=11)

- (c) Simplify the following Boolean function in both sum of products and product of sums. (8+8=16)

$$F(A, B, C, D, E) = \Sigma (0, 2, 4, 6, 9, 11, 13, 15, 17, 20, 21, 25, 27, 29, 31) + d(1, 3, 5, 7, 16, 19)$$

3. (a) Implement the function,  $f = \Pi (1, 3, 5, 7, 9, 13, 14, 15)$  using  $3 \times 8$  decoders (as many as required) and basic gates. Block symbol of the decoder is shown below. (10)

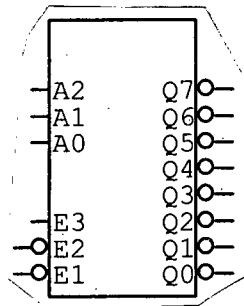

- (b) Obtain an  $8 \times 1$  MUX with a  $4 \times 1$  MUX having active low enable input and two  $2 \times 1$  MUXs having active high enable inputs. Use a block diagram construction for MUXs. Basic gates, if needed, may also be used. (9)

**CSE 205**

Contd ... Q. No. 3

(c) Implement the function,  $f(a, b, c, d) = \Sigma (1, 7, 9, 11, 15)$  using the constructed  $8 \times 1$  MUX of question no. 3(b). Use a, b, and d as selector inputs. (8)

(d) Draw the AND-OR implementation of the following Boolean function and then obtain a multilevel NAND logic diagram for it. Assume that complemented inputs are available. (8)

$$F = A(B + C D) + B'C$$

4. (a) Design an arithmetic circuit with two selection variables  $s_1$  and  $s_0$  that performs the following operations on two 4-bit binary numbers, A and B. (25)

| $s_1$ | $s_0$ | Operation               |
|-------|-------|-------------------------|
| 0     | 0     | A + 1's complement of B |
| 0     | 1     | A + 2's complement of B |
| 1     | 0     | A + B                   |
| 1     | 1     | A'                      |

Use 4-bit binary adders,  $4 \times 1$  MUXs and basic gates.

(b) Implement the function,  $f = \Sigma (0, 6)$  with NOR gates only. (10)

**SECTION – B**

There are **FOUR** questions in this Section. Answer any **THREE**.

5. (a) Design a circuit that receives continuous input of bits and generates outputs as per following requirement: (17)

| X    | Y    | Output |
|------|------|--------|
| Even | Even | 00     |
| Even | Odd  | 01     |
| Odd  | Even | 10     |
| Odd  | Odd  | 11     |

Here,

X = Number of ones in the input received so far

Y = Number of zeros in the input received so far

Design the circuit using T flip-flops and other basic gates.

(b) Design a three bit binary ripple counter with D flip-flops. (8)

(c) Given  $32 \times 8$  ROM chips each with an enable input, show the external connections necessary to construct a  $128 \times 8$  ROM with four such  $32 \times 8$  ROM chips and a decoder. (10)

6. (a) Design a J-K Flip-Flop using a T Flip-Flop and basic gates. (12)

**CSE 205**

Contd ... Q. No. 6

(b) Design a 3-bit universal shift register with the following options: (13)

| Mode Control |    |    | Register Operation |
|--------------|----|----|--------------------|
| S2           | S1 | S0 |                    |
| 0            | 0  | 0  | No Change          |
| 0            | 0  | 1  | Shift Right        |
| 0            | 1  | 0  | Shift Left         |
| 0            | 1  | 1  | Parallel Load      |
| 1            | 0  | 0  | Set all bits to 0  |
| 1            | 0  | 1  | Set all bits to 1  |
| 1            | 1  | 0  | Invert all bits    |
| 1            | 1  | 1  | No Change          |

(c) Briefly describe address multiplexing technique for DRAM with an appropriate example. (10)

7. (a) A sequential circuit has two flip-flops A and B, two inputs x and y, and one output z. The flip-flop input equations and circuit output equations are: (4+8+3=15)

$$J_A = A.x + B.y$$

$$K_A = A.B + x.y$$

$$J_B = A.x$$

$$K_B = A.B.x + B.y$$

$$z = A.x.y + B.x.y$$

For the above mentioned circuit:

- (i) Draw the logic diagram of the circuit
- (ii) Derive the state table
- (iii) Draw the state diagram

(b) Draw the circuit diagram of a four bit Johnson counter with required decoding. (10)

(c) Briefly Describe Programmable Array Logic (PAL) with an appropriate example. (10)

8. (a) Design a synchronous counter with the sequence given below: (12)

$$1 \rightarrow 2 \rightarrow 4 \rightarrow 5 \rightarrow 7 \rightarrow 1$$

(b) Design a synchronous BCD counter. Take appropriate measures for the unused states. (12)

(c) Design a circuit for the following functions using Programmable Logic Array (PLA).

Minimize the numbers of product terms. (11)

$$A(x, y, z) = \Sigma(0, 1, 2, 5, 7)$$

$$B(x, y, z) = \Sigma(0, 1, 3, 6, 7)$$

-----

**SECTION – A**

There are **FOUR** questions in this Section. Answer any **THREE**.

1. (a) Write the properties of an ideal Op-Amp. (7 2/3)  
 (b) Sketch the frequency response curves (both ideal and real) of all four kinds of active filters. Clearly level the pass band, stop band and cut-off frequency in your answer. (20)  
 (c) Write down the design procedure of a +40 dB/decade Butterworth High Pass Filter. Design a +40 dB/decade Butterworth High Pass Filter which will attenuate all signals having a frequency less than 150 KHz. Use  $C_1 = 0.1 \mu\text{F}$ . Also show its frequency response curve. (8+8+3)

2. (a) Using Op-Amps, propose a circuit which will produce following output.  
 (i)  $V_{out} = 7v_1 + 5v_2 - 3 \frac{dv_3}{dt}$  (13 1/3)  
 (ii)  $V_{out} = 7v_1 - 5v_3$  (13 1/3)

Here,  $v_1$ ,  $v_2$  and  $v_3$  are three different input sources.

- (b) Draw the circuit diagram of a smoke detector and also explain its working principle in brief. (20)
3. (a) Draw the circuit of a logarithmic amplifier and derive the expression of its output voltage. (12)  
 (b) For the NMOS amplifier shown below, derive the following expressions: (10+10)

(i)  $\frac{v_s}{v_i}$  (ii)  $\frac{v_d}{v_i}$

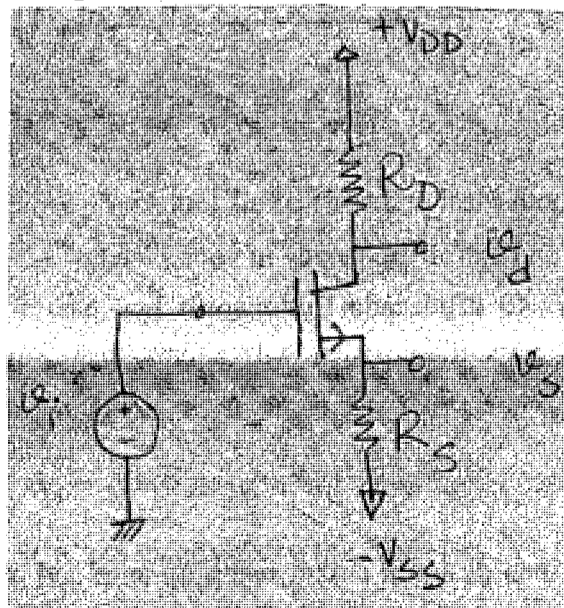

Fig. for Q. No. 3.(b)

**EEE 263**

**Contd ... Q. No. 3**

(c) Determine all the node voltages and branch currents for the circuit given below.

Assume,  $v_t = 1V$ ,  $K'_n \frac{W}{L} = 1mA/V^2$ ,  $\lambda = 0$

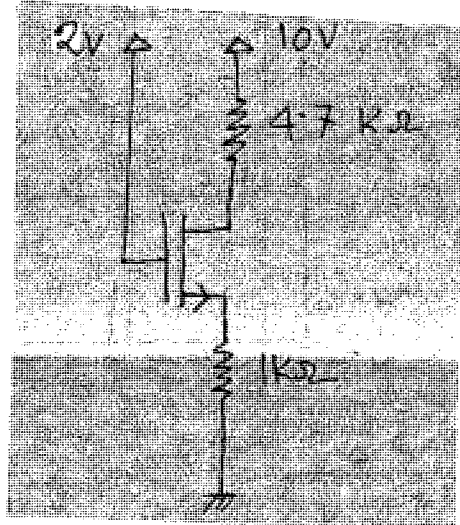

(14 2/3)

Fig. for Q. No. 3.(c)

- 4. (a) Explain the operating principle of a Silicon Controlled rectifier with the help of two transistor model. (20)
- (b) Draw the I-V characteristics of a SCR and a TRIAC. (3+3)
- (c) Draw the small signal equivalent circuit of the following amplifier. (12)

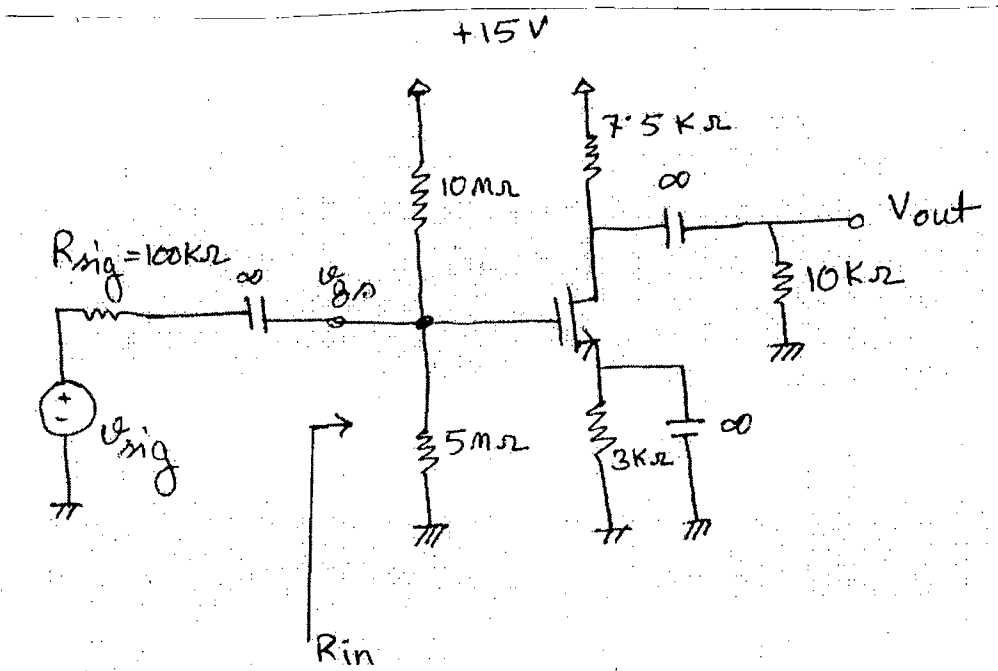

Fig. for Q. No. 4.(c)

(d) Draw the general circuit diagram of an inverting amplifier which takes 3 voltage sources as input. (8 2/3)

**SECTION - B**

There are **FOUR** questions in this Section. Answer any **THREE**.

- 5. (a) Sketch the output and transfer characteristics for the following rectifier circuit [fig. 5(a)].  $v_s$  is a sinusoid with 24-V peak amplitude and frequency 5 kHz. Assume the diode to be ideal. (16)



**EEE 263**

**Contd ... Q. No. 5(a)**

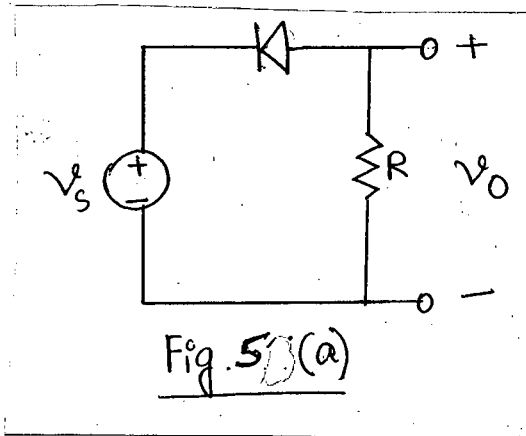

(b) Assuming that the diodes in the circuit [fig. 5(b)] are ideal, find the values of V and I. (15)

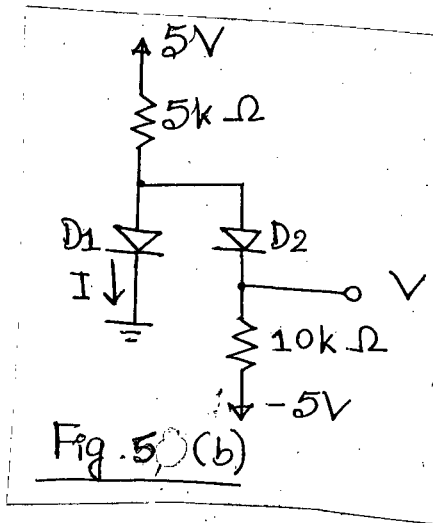

(c) In forward bias diode, I-V relationship is given by  $I = I_s (e^{V/nV_T} - 1)$ . Prove that the change in diode voltage is  $2.3 nV_T$  for a 10 times increase in diode current for a given diode. (15 $\frac{2}{3}$ )

6. (a) Determine the current  $I_D$  and diode voltage  $V_D$  for the circuit in fig. 6(a) using (15)

- (i) Piecewise Linear model ( $V_{D0} = 0.65 \text{ V}$ ,  $r_D = 20 \Omega$ )
- (ii) Constant voltage drop model ( $V_D = 0.65 \text{ V}$ )
- (iii) Ideal diode model.

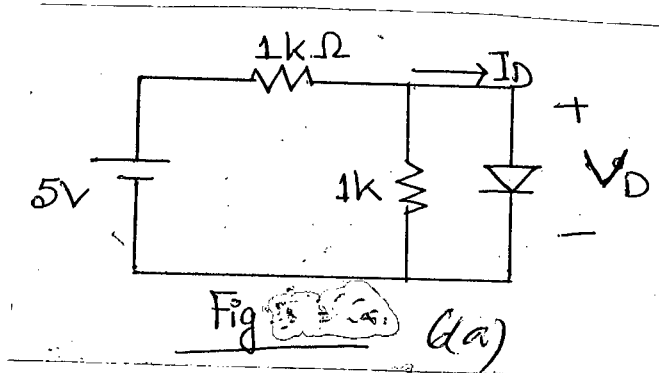

(b) With the help of the i-v characteristics of a zener diode, explain (10)

- (i) knee current
- (ii) dynamic resistance of a zener diode.

**EEE 263**

**Contd ... Q. No. 6**

(c) What is peak inverse voltage? Find the peak inverse voltage of a full-wave bridge rectifier. With necessary figures, explain how the use of a capacitor at the output of a half wave rectifier circuit filters the output. (21 2/3)

7. (a) In the circuit of fig. 7(a), the voltage at the emitter was found to be  $-0.7$  V. If  $\beta = 100$ , find  $I_E$ ,  $I_B$ ,  $I_C$  and  $V_C$ . (16)

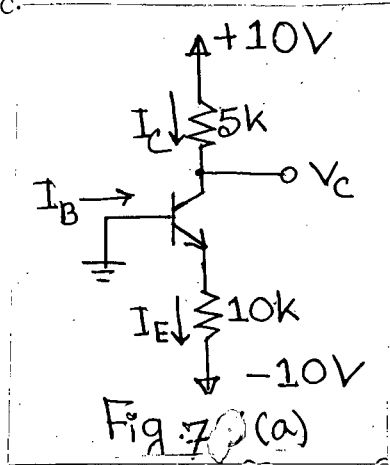

(b) What do you mean by early effect of a BJT? In fig 7(b), the transistor has  $\beta = 30$ . Find the values of  $V_B$ ,  $V_E$  and  $V_C$ . If  $R_B$  is increased to  $270$  k $\Omega$ , what are the new values? (20 2/3)

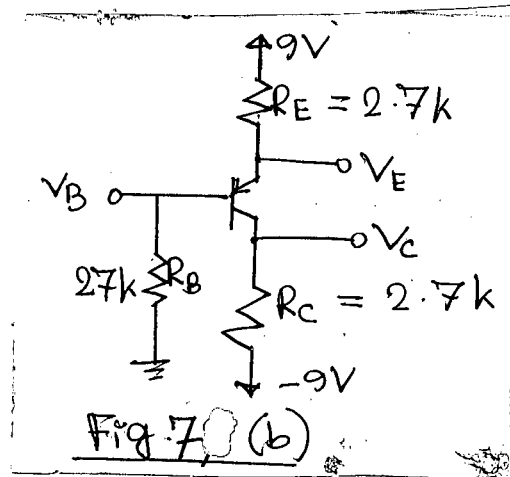

(c) Compare the band diagram of a metal, semiconductor and conductor. (10)

8. (a) The transistor in the common emitter amplifier [fig. 8(a)] has  $\beta = 100$  and  $V_A = 100$ . (20 2/3)

- (i) Calculate dc bias current  $I_E$
- (ii) Find  $R_{in}$ ,  $v_o/v_{sig}$  and  $i_o/i_i$

(b) For fig. 8(b) (i) Calculate  $5\tau$  & compare with period of applied signal (ii) Sketch  $v_o$ . (13)

(c) Draw the transfer characteristics of fig. 8(c). Indicate different regions of operation. (13)

**EEE 263**

**Contd ... Q. No. 8**

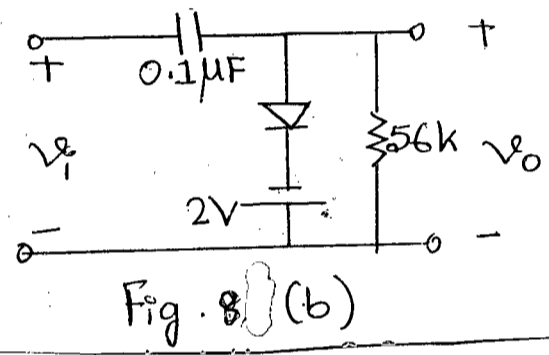
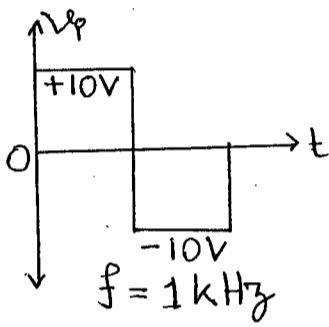
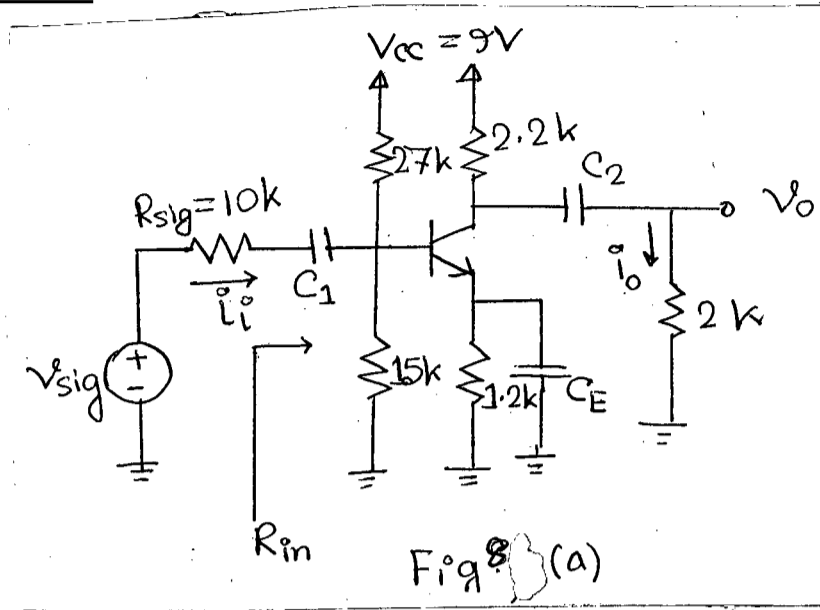

Diode forward voltage drop =  $0.7V$

