

SECTION - AThere are **FOUR** questions in this section. Answer any **THREE**.

1. (a) What is SCR? Describe its operation in different biasing mode. (10)

(b) Prove that average voltage of a full wave SCR rectifier can be given by, (8)

$$V_{av} = \frac{V_{max}}{\lambda (1 + \cos \alpha)}$$

where the symbols have usual meaning.

(c) Describe the operation of the circuit given in the figure for given V_s and pulse source at the gate of SCR. Also sketch (17)

- (i) Voltage across SCR
- (ii) Voltage across the induction
- (iii) V_o
- (iv) Voltage at cathode of SCR
- (v) Current i

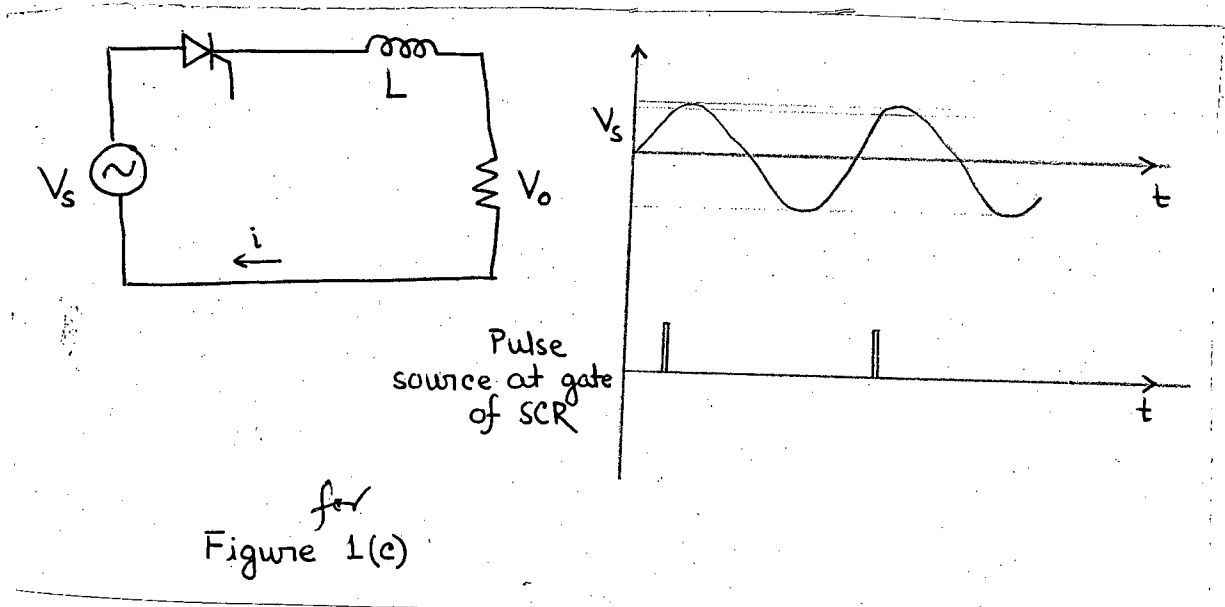

2. (a) How parabolic output can be obtained from a square wave input? Derive the relationship between input and output waves in terms of circuit components. (15)

(b) What is virtual ground? Prove that in case of differential amplification using Opamp, output changes linearly with the difference in input signals. (12)

(c) Explain loading effect. How op-amp can be used to eliminate this effect? (8)

EEE 271

3. (a) Find the transfer characteristics of the following circuit. (15)

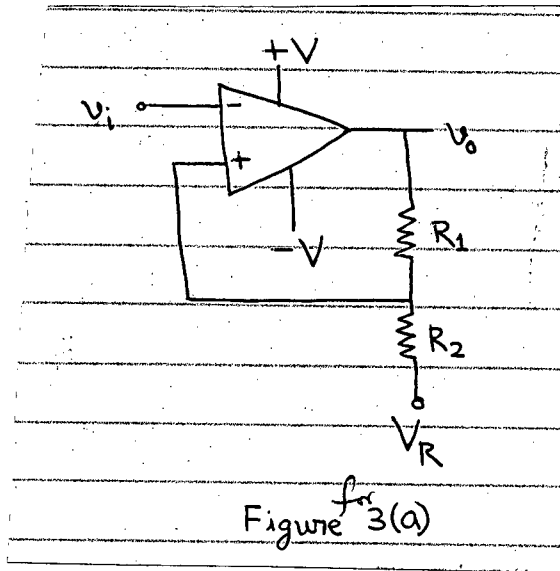

(b) Sketch the phasor diagram of synchronous generator for three different types of load. (9)

(c) Prove that maximum power developed in a synchronous generator is inversely proportional to the synchronous reactance. (11)

4. (a) Draw the equivalent circuit of a three phase synchronous motor. (5)

(b) Explain – "A synchronous motor can be operated as a capacitive load". (12)

(c) A 208 V, 45 KVA, 0.8 pf leading Y connected, 50 Hz synchronous motor is supplying a 14 hp load with an initial p.f. of 0.85 lagging. Field current I_F at this condition is 4.0 A. (18)

(i) Sketch initial phasor diagram of the motor and find \bar{I}_A and \bar{E}_A .

(ii) If the motor's flux is increased by 30%, sketch the change in phasor diagram of the motor.

(iii) What are \bar{I}_A , \bar{E}_A and power factor of the motor in the later condition?

SECTION – B

There are **FOUR** questions in this section. Answer any **THREE**.

5. (a) Using the principle of motor action, explain how a rectangular coil can rotate in a magnetic field when current is supplied to it. Also discuss why commutation is necessary here to produce a continuous rotation. (12)

(b) Describe methods for speed control of DC series motor. (9)

(c) A 440 V DC shunt motor runs at 1200 rpm and 24 A current on full load. The motor armature resistance is 1.1 Ω , brush contact drop is 1.5 V, resistance in the shunt regulator is 50 Ω , Iron and friction losses on full load are 340 W. Calculate: (14)

(i) Efficiency on full load

(ii) Gross torque developed

(iii) Shaft torque

EEE 271

6. (a) Draw the equivalent circuit of a single phase ideal transformer. Explain the imperfections present in a practical transformer and draw the equivalent circuit including these imperfections. (10)

(b) Why short circuit test of a transformer is done on the high side and open circuit test is done on low side of the transformer. (8)

(c) A 20 KVA, 20,000/480 V, 50 Hz distribution transformer is tested with the following results: (17)

Open circuit test:	Short circuit test:
$V_{oc} = 480 \text{ V}$	$V_{sc} = 1130 \text{ V}$
$I_{oc} = 1.6 \text{ A}$	$I_{sc} = 1 \text{ A}$
$P_{oc} = 305 \text{ W}$	$P_{sc} = 260 \text{ W}$

(i) Find the equivalent circuit of the transformer from primary side.

(ii) Find the voltage regulation and efficiency at 0.9 pf leading with full load.

7. (a) Explain the principle of operation of a 3 phase induction motor. How rotating magnetic flux builds up in an induction motor? (17)

(b) A 440 V, 50 Hz, 2 pole, Y connected induction motor is rated at 75 KW. The equivalent circuit parameters are (18)

$$R_1 = 0.075 \Omega, R_2 = 0.065 \Omega, X_M = 7.2 \Omega, X_1 = 0.17 \Omega, X_2 = 0.17 \Omega$$

Core loss, friction and windage loss and stray loss of the induction motor are 1.1 KW, 1 KW and 150 W respectively. Find the following:

- (i) Line current
- (ii) Airgap power
- (iii) Converted power
- (iv) Overall efficiency

8. (a) Derive the equation for terminal characteristics of a shunt DC motor. (10)

(b) Explain the full range speed control of shunt DC motor. (15)

(c) Draw equivalent circuit of a long shunt compounded DC motors. (10)

BANGLADESH UNIVERSITY OF ENGINEERING AND TECHNOLOGY, DHAKA

L-2/T-1 B. Sc. Engineering Examinations 2010-2011

Sub : **MME 295** (Engineering Materials II)

Full Marks: 140

Time : 3 Hours

The figures in the margin indicate full marks.

USE SEPARATE SCRIPTS FOR EACH SECTION

SECTION – AThere are **FOUR** questions in this Section. Answer any **THREE**.

1. (a) Define sintering process and describe its stages in brief. (7)
- (b) Differentiate among bisque firing, glost firing and decoration firing for white-ware production. (6)
- (c) Explain mechanism of drying showing how drying rate in moisture gradient change with time. (10 ⅓)

2. (a) Define glass. What are the basic requirements for glass forming? (5 ⅓)
- (b) Glass reinforcement is possible in several ways — explain in detail. (12)
- (c) Describe press-and blow technique for producing a glass bottle. (6)

3. (a) A continuous and aligned glass fibre-reinforced composite consists of 40 Vol.% glass fibres having a modulus elasticity of 69 GPa and 60 Vol.% polyester resin that when hardened, displays a modulus of 3.4 GPa. (14 ⅓)
 - (i) compute the modulus of elasticity of the composite in the longitudinal direction.
 - (ii) if the cross-sectional area is 250 mm² and a stress of 50 MPa is applied in the longitudinal direction, compute the magnitude of the load carried by each of the fibre and matrix phases.
 - (iii) Determine the strain that is sustained by each phase when the stress in part (ii) is applied.
- (b) How strengthening mechanism depends on particle size in particle-reinforced composites? (4 ½)
- (c) Explain how composite stiffness varies with fibre orientation. (4 ½)

4. (a) Describe the common types of polymer molecular structures. (6)
- (b) Explain two types of polymerization reactions with examples. (10)

MME 295

Contd ... Q. No. 4

(c) Calculate the degree polymerization if 6,6 nylon has a molecular weight of 120,000 g/mol. [1 mol hexamethylene diamine and 1 mole adipic acid react to form 1 mol 6,6 nylon and 2 mol of water] The molecular weights are 116 g/mol for hexamethylene diamine, 146 g/mol for adipic acid and 18 g/mol for water. The repeated unit for 6,6 nylon is.

(7 1/3)

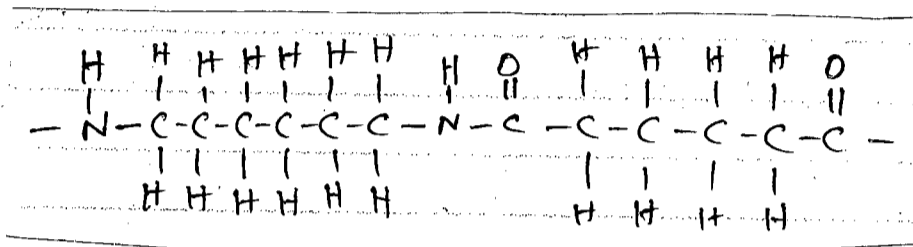

SECTION - B

There are **FOUR** questions in this Section. Answer any **THREE**.

5. (a) What are ceramic materials? Compare the general characteristics of ceramic materials with those of metals and polymers. (2 1/3 + 6 = 8 1/3)
 (b) Classify ceramic materials based on composition and application. Give at least two examples of each category. (10 + 5 = 15)

6. (a) Indicate and explain two of the most important drawbacks of engineering ceramics. Discuss how you can rectify those problems. (2 + 4 + 4 = 10)
 (b) Using neat 3D sketch, explain the perovskite structure of ceramics. Discuss one important characteristic of BaTiO₃ that is attributed due to its perovskite structure. (2 + 3 + 3 = 8)
 (c) Draw SiO₂- Al₂O₃ phase diagram and label it completely. (3 + 2 1/3 = 5 1/3)

7. (a) Using neat sketches, describe the typical strength distribution curve of metals and ceramics. "The Weibull modulus of a ceramics is 10." What does this statement tell you about the mechanical properties of this ceramic material? (2 1/3 + 5 = 7 1/3)
 (b) A series of tests on a ceramic component indicates that 25% of the samples fail at stresses below 210 MPa while only 10% fail at stresses below 195 MPa. Determine the Weibull modulus and the maximum allowable stress if only 1 failure per 1000 specimens can be tolerated. (10)
 (c) Distinguish between the followings: (6)
 Earthenware, Faience, Terracota, Stoneware, Porcelain, Bone china.

MME 295

8. (a) Discuss the mechanism of drying of clay-base ceramic materials and its effect on the formation of moisture gradient and size change in ceramics. (7 $\frac{1}{3}$ + 4 + 4 = 15 $\frac{1}{3}$)

(b) Find a suitable recipe for the glaze to be used on certain ceramic material using the following Seger formula of the glaze body: (8)

0.3 K₂O 0.4 Al₂O₃ 4.0 SiO₂
0.1 MgO
0.6 CaO

The raw materials to be used are as follows:

Orthoclase (K₂O.Al₂O₃.6SiO₂), Dolomite (CaO.MgO.CO₂), Whiting (CaO.CO₂), China clay (Al₂O₃.2SiO₂.2H₂O), and Flint (SiO₂).

The figures in the margin indicate full marks.

Symbols indicate their usual meanings. Assume reasonable values for any missing data.

USE SEPARATE SCRIPTS FOR EACH SECTION

SECTION – A

There are **FOUR** questions in this Section. Answer any **THREE**.

1. (a) Two involute gears of 20° pressure angle are in mesh. The number of teeth on pinion is 20 and the gear ratio is 2. If the pitch expressed in module is 5 mm and the pitch line speed is 1.2 m/s, assuming addendum as standard and equal to one module, find (20)
 - (i) The angle turned through by pinion when one pair of teeth is in mesh and
 - (ii) The maximum velocity of sliding.
- (b) Two shafts A and B are co-axial as shown in Fig. for Q. 1(b). A gear C (50 teeth) is rigidly mounted on shaft A. A compound gear D-E gears with C and an internal gear G. D has 20 teeth and gears with C and E has 35 teeth and gears with an internal gear G. The gear G is fixed and is concentric with the shaft axis. The compound gear D-E is mounted on a pin which projects from an arm keyed to the shaft B. Find the number of teeth on internal gear G assuming that all gears have the same module. If the shaft A rotates at 110 rpm, find the speed of shaft B. (26 $\frac{2}{3}$)
2. In a quick return mechanism, as shown in Fig. for Q. 2, the driving crank OA is 60 mm long and rotates at a uniform speed of 200 r.p.m. in clockwise direction. For the position shown, find: (46 $\frac{2}{3}$)
 - (i) Velocity of the ram R
 - (ii) Acceleration of the ram R
 - (iii) Acceleration of the sliding block A along the slotted bar CD.
3. Draw the profile of the cam when the roller follower moves with cycloidal motion during outstroke and return stroke, as given below: (46 $\frac{2}{3}$)
 - (i) Outstroke with maximum displacement of 31.4 mm during 180° of cam rotation.
 - (ii) Return stroke for the next 150° of cam rotation.
 - (iii) Dwell for the remaining 30° of cam rotation.

The minimum radius of the cam is 15 mm and the roller diameter of the follower is 10 mm. The axis of the roller follower is offset by 10 mm towards right from the axis of the cam shaft.

ME 245

4. (a) A shaft carries four masses in parallel planes A, B, C and D in this order along its length. The masses at B and C are 18 kg and 12.5 kg respectively, and each has an eccentricity of 60 mm. The masses at A and D have an eccentricity of 80 mm. The angle between the masses at B and C is 100° and that between the masses at B and A is 190° , both being measured in the same direction. The axial distance between the planes A and B is 100 mm and between B and C is 200 mm. If the shaft is in complete dynamic balance, determine:

(26 $\frac{2}{3}$)

- (i) The magnitude of the masses at A and D
- (ii) The distance between planes A and D
- (iii) The angular position of the mass at D.

(b) A shaft rotating at 200 r.p.m. drives another shaft at 300 r.p.m. and transmits 6 KW through a belt. The belt is 100 mm wide and 10 mm thick. The distance between the shafts is 4 m. The smaller pulley is 0.5 m in diameter. Calculate the stress in the belt, if it is

(20)

- (i) An open belt drive, and
 - (ii) A cross belt drive
- Take, $\mu = 0.3$

SECTION - B

There are **FOUR** questions in this Section. Answer any **THREE**.

5. (a) Collars A and B are connected by a 500 mm-long wire and can slide freely on frictionless rods. Determine the distance x and z for which the equilibrium of the system is maintained if P = 120 N and Q = 60 N. Refer to Fig. for Q. 5(a).

(23 $\frac{2}{3}$)

(b) For the shift lever shown in Fig. for Q. 5(b), determine the direction and magnitude of the smallest force P which creates a 21 N.m clockwise moment about B.

(23)

6. (a) A pitched flat roof truss is loaded as shown in Fig. for Q. 6(a). Determine the force in members EG, GH, and HJ. Use method of joints and start from joint I.

(23 $\frac{2}{3}$)

(b) The position of member ABC is controlled by the hydraulic cylinder CD. Given $\theta = 30^\circ$, determine for the loading shown in Fig. for Q. 6(b) (i) the force exerted by the cylinder on pin C (ii) the reactions at B.

(23)

ME 245

7. (a) Determine by direct integration the centroid of the plane area shown in Fig. for Q. 7(a). (23 $\frac{2}{3}$)
- (b) The machine element shown in Fig. for Q. 7(b) is fabricated from steel. Determine the element's mass moment of inertia about the y-axis. (The density of steel is 7850 kg/m³.) (23)
8. (a) The cylinder shown is of weight W and radius r. Express in terms of W and r the magnitude of the largest Couple M which can be applied to the cylinder if it is not to rotate. Given the coefficient of static friction is 0.30 at A and B. See Fig. for Q. 8(a). (23)
- (b) For the system shown in Fig. for Q. 8(b) block A is on a rough surface ($\mu_s = 0.30$, $\mu_k = 0.25$) but block B is on a smooth surface ($\mu = 0$). Determine the mass of B for the following cases (23 $\frac{2}{3}$)
- (i) To maintain static equilibrium.
 - (ii) To accelerate block A upward at 1 m/s² along the plane. Ignore friction in the pulley.
-

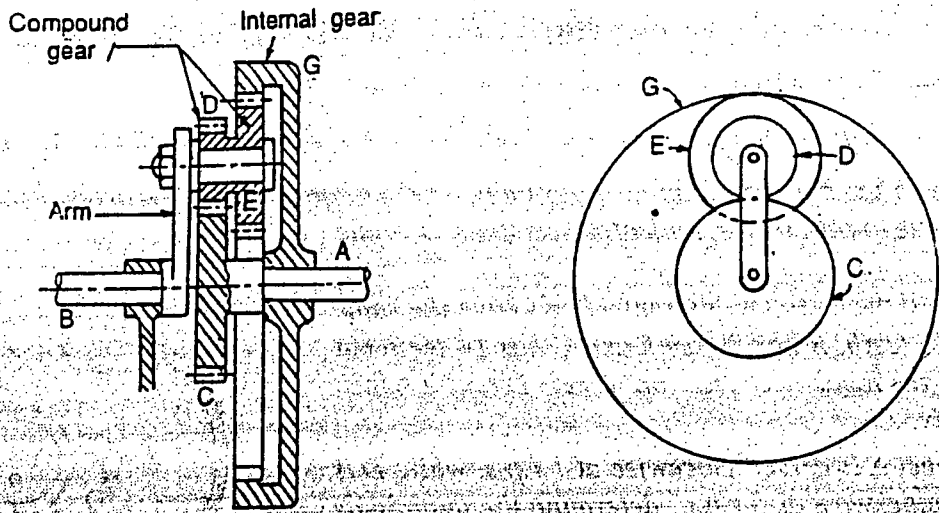

Fig. for Q1(b)

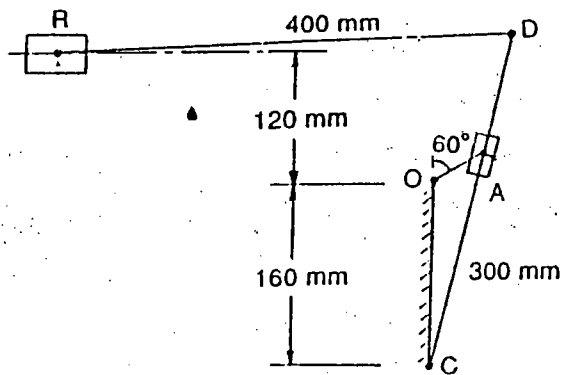

Fig. for Q-2

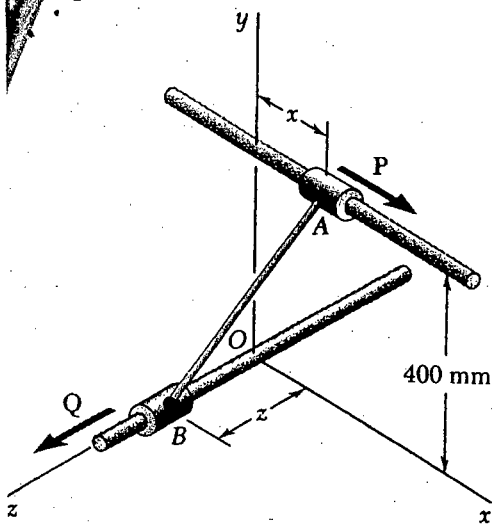

FIG. for Q. 5(a)

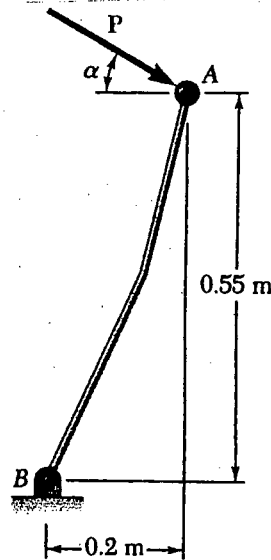

FIG. for Q. 5(b)

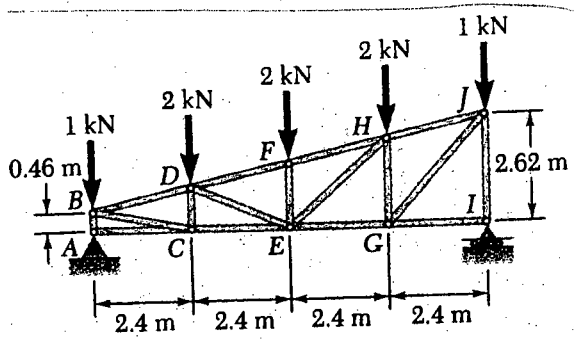

FIG. for Q. 6(a)

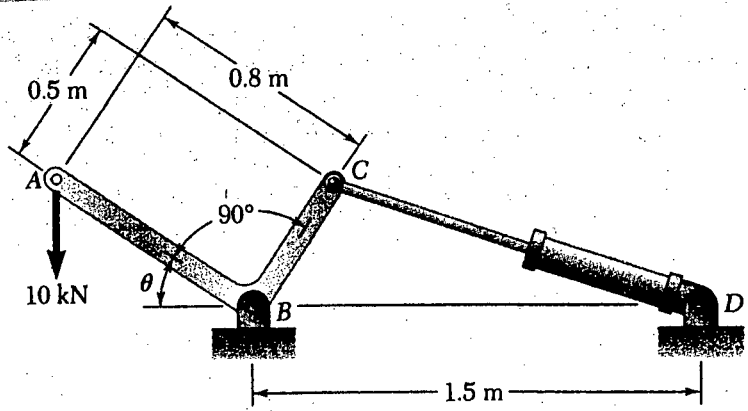

FIG. for Q. 6(b)

[Faint handwritten notes and stamps]

SECTION - AThere are **FOUR** questions in this Section. Answer any **THREE**.

1. (a) Solve the following differential equations

(i) $(3x - 7y - 3) \frac{dy}{dx} = 3y - 7x + 7$ (14)

(ii) $\sec^2 y \frac{dy}{dx} + (\tan y) 2x = x^3$ (10)

- (b) If the population of a country doubles in 50 years, in how many years will it treble (three times) under the assumption that the rate of increase is proportional to the number of inhabitants? (11)

2. Find the general solution of the following higher order differential equations:

(a) $(D^3 - 2D + 4)y = e^x \sin x$ (10)

(b) $(D^3 - 7D - 6)y = x^3 e^{2x}$ (12)

(c) $(x^3 D^3 + 2x^2 D^2 - xD + 1)y = \frac{1}{x}$ (13)

3. (a) Using Fröbenius method obtain a general solution in series of powers of
- x
- of the

equations $x \frac{d^2 y}{dx^2} + \frac{dy}{dx} + x^2 y = 0$ (25)

(b) show that $\int_{-1}^1 [P_n(x)]^2 dx = \frac{2}{2n+1}$ (10)

4. (a) Show that $J_{\frac{1}{2}}(x) = \sqrt{\frac{2}{\pi x}} \sin x$ (10)

(b) Show that $\cos x = J_0(x) - 2J_2(x) + 2J_4(x) \dots$ (13)

(c) Show that $P_{n+1}'(x) - P_{n-1}'(x) = (2n+1)P_n(x)$ (12)

MATH 291 (IPE)

SECTION - B

There are **FOUR** questions in this Section. Answer any **THREE**.

5. (a) A particle moves along the curve $x = 2t^2$, $y = t^2 - 4t$, $z = 3t - 5$, where t is the time. Find the components of its velocity and acceleration at time $t = 1$ in the direction $\underline{i} - 3\underline{j} + 2\underline{k}$. (10)

(b) State and prove Frenet - Serret formulae. (15)

(c) Find Curl (ϕ grad ϕ). (10)

6. (a) Prove that $\underline{F} = r^2 \underline{r}$ is conservative and find the scalar potential. (15)

(b) State Gauss's divergence theorem. Verify the divergence theorem for $\underline{A} = 2x^2 y \underline{i} - y^2 \underline{j} + 4xz^2 \underline{k}$ taken over the region in the first octant bounded by $y^2 + z^2 = 9$ and $x = 2$. (20)

7. (a) Find the Laplace transform of (i) $\sin \sqrt{t}$ and then (ii) $\frac{\cos \sqrt{t}}{\sqrt{t}}$. (17)

(b) Evaluate (i) $L \left\{ \frac{\int_0^t 1 - e^{-u} du}{u} \right\}$ (ii) $\left\{ \int_0^\infty t e^{-3t} \sin t dt \right\}$. (18)

8. (a) Find $L^{-1} \left\{ \frac{s}{(s^2 + a^2)^2} \right\}$ (10)

(b) Find $L^{-1} \left\{ \frac{e^{-\frac{1}{s}}}{s} \right\}$ (12)

(c) Using Laplace transform solve $tY'' + Y' + 4tY = 0$, $Y(0) = 3$, $Y'(0) = 0$. (13)

BANGLADESH UNIVERSITY OF ENGINEERING AND TECHNOLOGY, DHAKA

L-2/T-1 B. Sc. Engineering Examinations 2010-2011

Sub : **HUM 313** (Principles of Accounting)

Full Marks: 140

Time : 3 Hours

The figures in the margin indicate full marks.

USE SEPARATE SCRIPTS FOR EACH SECTION

SECTION – AThere are **FOUR** questions in this Section. Answer any **THREE**.1. (a) Who are the users of accounting information? (3 1/3)(b) Mr. Zaman is a licensed architect. During the first month of the operation of his firm, the following transactions occurred: (20)

- (i) Started his firm investing Tk. 500,000 cash and equipment Tk. 90,000.
- (ii) Paid office rent in advance Tk. 4,000 cash for two months.
- (iii) Purchased a car for office purpose for Tk. 100,000. Paid cash Tk. 30,000 and signed a notes payable for Tk. 70,000.
- (iv) Received cash Tk. 50,000 for performing services.
- (v) Paid Tk. 5,000 cash for advertising bill.
- (vi) Withdraw Tk. 10,000 cash from the firm for her personal use.
- (vii) Purchased office supplies for cash Tk. 2,000.
- (viii) Service rendered and earned Tk. 10,000 but not yet received.
- (ix) Performed another service on account for Tk. 10,000.
- (x) Cash received Tk. 9,500 for service-ix.

Required: Show the effects of transactions on the accounting equation.

2. Zidan Inc. opened a Law office. During May, the following transactions occurred: (23 1/3)

- May-1: Services performed but not yet received Tk. 5,000.
- May-5: Purchase furniture Tk. 10,000 on account.
- May-7: Earned revenue of Tk. 10,000 of which Tk. 8,000 is collected in cash and the balance due for next month.
- May-10: Paid salaries Tk. 1,000; rent Tk. 900; advertising expense Tk. 500.
- May-12: Withdraw of cash Tk. 500 for personal use.
- May-20: Received Tk. 5,000 from a local bank signed as a notes payable.

Required:

- (i) Journalize each transactions.
- (ii) Post the journal entries to the ledger accounts.
- (iii) Prepare a trial Balance on May.

HUM 313

4. Mr. Rafique has opened his business in the name of Cyber Line System at January, 2008. After one year of operation the adjusted trial balance is given below:

Cyber Line System
Adjusted Trial Balance
December 31, 2008

Accounts title	Debit (Tk.)	Credit (Tk.)
Capital		100,000
Prepaid Advertising	10,000	
Cash	50,000	
Supplies	20,000	
Notes payable		45,000
Salaries expense	20,000	
Service Revenue		40,000
Unearned Service Revenue		50,000
Furniture	100,000	
Drawings	2,000	
Salaries payable		7,000
Utility expense	50,000	
Depreciation expense	5,000	
Accounts receivable	5,000	
Accumulated depreciation		20,000
Total =	<u>262,000</u>	<u>262,000</u>

Required:

- (a) Prepare an income statement, Owner's Equity Statement and a classified Balance Sheet assuming that 80% of the notes payable are long term. (20 ¹/₃)
- (b) Compute– Current ratio, Quick Ratio, Net profit margin. (3)

SECTION – B

There are **FOUR** questions in this Section. Answer any **THREE**.

5. (a) What are the different methods of allocating service departments' costs over production departments? Which one is the best and why? (3 ¹/₃)
- (b) Visic Consulting provides outsourcing services and advices to both government and corporate clients. For costing purpose, Visic classifies its departments into two service

HUM 313

3. (a) What are the basic reasons of recording adjusting entries? Explain with examples. **(3 1/3)**
(b) The Trial Balance of Watson Co. at June 30, 2011 is shown below- **(20)**

Watson Company
Trial Balance
June 30, 2011

Accounts title	Debit (Tk.)	Credit (Tk.)
Cash	152,000	
Supplies	2,500	
Prepaid Insurance	3,000	
Office Equipment	5,000	
Notes Payable		5,000
Accounts payable		2,500
Unearned revenues		1,200
Capital		10,000
Drawing	500	
Service Revenue		10,000
Salaries expenses	4,000	
Utilities expenses	900	
Total =	<u>28,700</u>	<u>28,700</u>

Analysis reveals the following additional data:

- (i) Supplies on hand Tk. 1,200.
- (ii) Insurance policy is for two years.
- (iii) Depreciation for each month is Tk. 100.
- (iv) Unearned revenue is total Tk. 800.
- (v) Service provided but not recorded at June 30, 2011 are Tk. 1,200.
- (vi) Interest accrued at June 30, is Tk. 200.
- (vii) Unpaid salary is Tk. 2,000.
- (viii) Utility incurred Tk. 1,500, but not recorded.

Required:

Prepare the adjusting entries for the items above and also prepare adjusted trial balance for June 30, 2011.

HUM 313

Contd ... Q. No. 5(b)

departments (Human Resources and Information System) and two producing departments (Government Consulting and Corporate Consulting). For the first quarter of 2010, overhead costs across the departments and other relevant data for allocating service departments costs over production departments are given below:

(15)

	Service Department		Production Department	
	Human Resource	Information System	Government Consulting	Corporate Consulting
Overhead costs before allocation (Tk)	6,00,000	24,00,000	87,56,000	1,24,52,000
Services rendered by Human Resource Deptt: Budgeted Labour Hours in %	—	25%	40%	35%
Information System Deptt: Budgeted Computer Hours in %	10%	—	30%	60%

Required: Allocate the service departments costs to the production departments using Direct Method and Reciprocal Service Method.

(c) Production overhead costs of three production departments x, y and z of Dhaka Engineering Co. are Tk. 33,990, Tk. 28,615 and Tk. 31,395 respectively. There are 125 working days of 8 hours each and each department has 7, 5 and 5 number of workers.

(5)

Required:

- (i) Calculate the labour hour rate each department.
- (ii) What will be the cost of a product if it's direct material cost is Tk. 50, direct labour cost is Tk. 40 and it passes through department x, y and z for 7, 5, and 2 hours respectively.

6. (a) "There could be three types of inventories on a manufacturing company's balance Sheet" — What are those three types of inventories?

(5)

(b) The following cost and inventory data for last year are taken from the accounting books of Eccles Company:

(18 1/3)

<u>Inventories</u>		
	Beginning (Tk)	Ending (Tk)
Finished goods	18,000	12,000
Work-in-process	12,000	10,000
Raw materials	13,000	16,000

HUM 313

Contd ... Q. No. 6(b)

Other data

	<u>Tk.</u>
Raw materials purchased	73,000
Direct labour	25,000
Utilities (70% for factory, 30% for office)	8,000
Maintenance, factory	3,000
Administrative Expenses	9,000
Factory rent	8,000
Depreciation– office building	7,000
Depreciation– machinery	6,000
Advertisement	3,000
Legal fees	2,000
Sales salaries	8,000
Supplies (40% for factory, 40% for office and 20% for sales)	6,000
Indirect labour	4,000
Sales	180,000

Required:

- (i) Prepare a statement of cost of goods sold.
 - (ii) Prepare an income statement.
7. (a) What is meant by the term operating leverage? Explain how it is useful in planning business operations. (5)

(b) North Wood Company manufactures basketballs that sell for Tk. 25 each. Variable costs are Tk. 15 per ball. Last year, the company sold 30,000 balls, with the following results: (18 1/3)

	<u>Tk.</u>
Sales (30,000 balls)	750,000
Less: Variable costs	450,000
Contribution margin	300,000
Less: Fixed costs	210,000
Net income	90,000

Required:

- (i) Compute the CM ratio, the break-even point in balls and the degree of operating leverage at last year's level of sales.

HUM 313

Contd ... Q. No. 7(b)

- (ii) If variable costs increases by Tk. 3 per ball next year and the selling price per ball remains constant at Tk. 25, what will be the new CM ratio and break-even point in balls?
- (iii) Refer to the data (ii) above, how many balls will have to be sold next year to earn the same net income as last year?
- (iv) Refer to the original data, the company is discussing the construction of a new plant which would slash variable costs per ball by 40% and would cause fixed costs to double in amount per year. Prepare a contribution format income statement assuming 30,000 balls will be produced and sold. Would you recommend the construction of the new plant?

8. (a) Discuss the concepts– costs, expenses, losses and assets. Give one example illustrating the relationship among these four. (4)

(b) Suppose that you are a garment manufacturer. You produce high quality luxurious garment from fine cloth that is supplied by a local supplier. Your manufacturing cost is composed of three types of costs– direct materials cost, direct labour costs and manufacturing overhead cost. Name different types of cost for your company. (5)

(c) The data below have been taken from the cost records of Frankel Company, a parcel service firm: (14 $\frac{1}{3}$)

If a delivery truck is driven 120,000 miles during a year, the average operating cost is Tk. 11.6 per mile. If a truck is driven only 80,000 miles during a year, the average operating cost increases to Tk. 13.6 per mile.

Required:

- (i) Using the high and low point method, determine the variable cost per mile driven and the total fixed operating cost per year.
 - (ii) Express the variable and fixed costs in the form $Y = a + bx$.
 - (iii) If a truck is driven 100,000 miles during a year, what total operating cost would you expect to be incurred?
-