

SECTION – AThere are **FOUR** questions in this Section. Answer any **THREE**.

1. (a) Show with neat sketches the typical layout of a diversion headworks. (6)
- (b) Explain the earth quake forces to be considered during design of a gravity dam. (7)
- (c) State the functions of silt excluder. Briefly describe the design considerations of various components of a silt excluder. (10 1/3)

2. (a) State the considerations for selection of a site for constructing a dam. (6)
- (b) Discuss how the loose protection works (Inverted filter and Launching Apron) at the downstream end of a weir or barrage are designed. Draw necessary figure. (7)
- (c) What are the data to be collected before designing a weir or barrage? Describe how the following factors are decided while designing a weir or barrage: (i) Crest Levels, (ii) Afflux, (iii) Waterway and discharge per meter, (iv) Pond Level. (10 1/3)

3. (a) Briefly describe the main features and working principles of (i) shaft spillway and (ii) siphon spillway. (8)
- (b) Figure 1 shows the section of a non-overflow portion of a gravity dam built of concrete. Neglecting the earth quake effects, calculate (15 1/3)
 - (i) major principal stress at toe.
 - (ii) shear stress on a horizontal plane near toe.
 Assume the unit weight of concrete as 24 kN/m^3 .

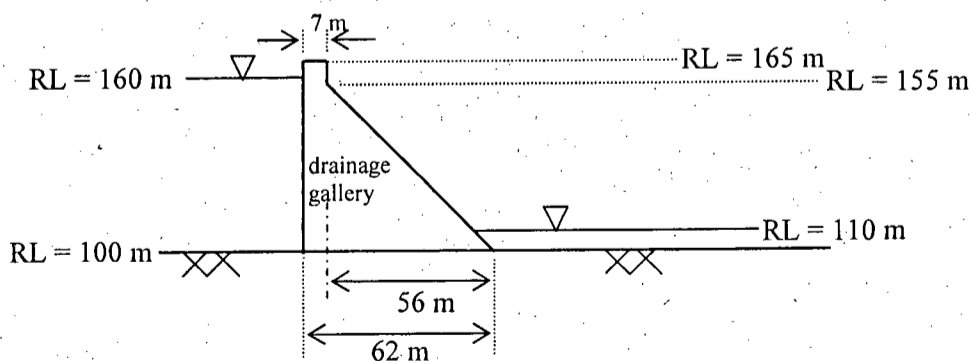

Figure 1 for Ques. 3 (b)

WRE 411(CE)

4. (a) Explain the mode of shear failure in a gravity dam and also the criteria for stability against this failure. (5)

(b) Design a suitable section for the over flow portion of a concrete gravity dam having d/s face sloping 3H : 1V. The design discharge for the spillway is 5250 cumec. The height of the spillway above the river bed is 60 m. The spillway length consists of 5 spans having a clear width of 10 m each and thickness of each pier is 2 m. Assume reasonable value of any missing data. (18 1/3)

SECTION - B

There are **FOUR** questions in this Section. Answer any **THREE**.

5. (a) Define hydraulic structures. Write down the major characteristics of hydraulic structures. (6 1/3)

(b) Determine the percentage uplift pressures at C₁, E₂, C₂, D₂, E₃ for the structure shown in Fig. 2 using Khola's formula and apply necessary corrections. The correction factors for 1 : 3 and 1 : 5 slopes are 4.5 and 2.8 respectively. Also compute the exit gradient for pond level and no flow downstream. (17)

Relevant equations are given below :

For sheet pile line on the u/s or d/s side

$$\Phi_E = \frac{1}{\pi} \cos^{-1} \left(\frac{\lambda - 2}{\lambda} \right); \Phi_D = \frac{1}{\pi} \cos^{-1} \left(\frac{\lambda - 1}{\lambda} \right); \lambda = \frac{1 + \sqrt{1 + \alpha^2}}{2};$$

For sheet pile line at some intermediate point

$$\Phi_E = \frac{1}{\pi} \cos^{-1} \left(\frac{\lambda_1 - 1}{\lambda} \right); \Phi_D = \frac{1}{\pi} \cos^{-1} \left(\frac{\lambda_1}{\lambda} \right); \Phi_C = \frac{1}{\pi} \cos^{-1} \left(\frac{\lambda_1 + 1}{\lambda} \right); \lambda = \frac{\sqrt{1 + \alpha_1^2} + \sqrt{1 + \alpha_2^2}}{2};$$

$$\lambda_1 = \frac{\sqrt{1 + \alpha_1^2} - \sqrt{1 + \alpha_2^2}}{2};$$

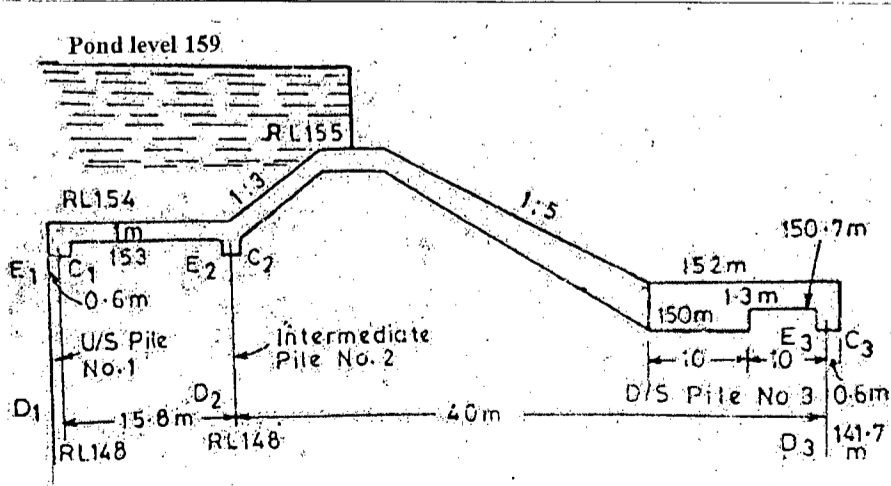

Contd P/3

Figure.2 for ques 5(b)

WRE 411(CE)

6. (a) Differentiate between Bligh's creep theory and Lane's weighted creep theory. (4)
- (b) What is critical exit gradient? Show that for most of river sands, value of critical exit gradient is unity. (6)
- (c) What are the factors govern the selection of suitable type of cross-drainage works. (5 1/3)
- (d) Fig. 3 shows a hydraulic structure built on fine sand ($C = 15$). Determine whether the percolation gradient is safe. Also calculate the floor thickness at point A. Make use of Bligh's theory and take $G = 2.24$. (8)

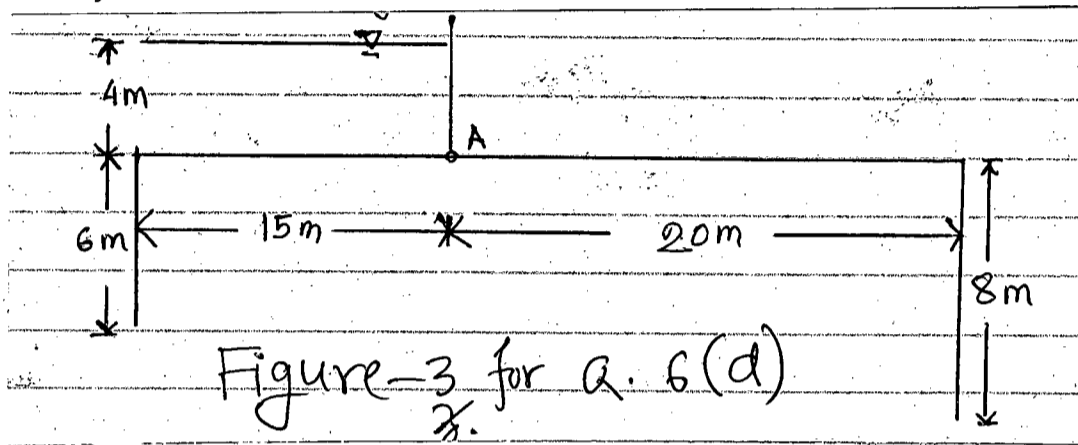

7. (a) What are the types of hydraulic structures? Show protection based classification with examples. (9)
- (b) Write short notes on (3×3=9)
- (i) Equipotential lines; (ii) Failure of structure (iii) Hydropower plant structure. (2+3 1/3=5 1/3)
- (c) What are the corrections applied for determining the percentage of pressure at various key points of hydraulic structures? Explain, why it is necessary?
8. (a) What are the considerations during design of bottom floor of aqueduct and syphon aqueduct? (8)
- (b) Show in neat sketch (i) Super passage; (ii) Type II aqueduct (4)
- (c) An aqueduct is to be designed for the following situation (11 1/3)

| | Canal | Drain |
|------------------------|-----------|-------|
| Discharge, (cumec) | 30 | 250 |
| Canal, FSL (m) | 251.5 | - |
| Depth of water (m) | 1.5 | - |
| Canal bed level (m) | 250 | - |
| Bed width (m) | 20 | - |
| Side slopes | 1.5H : 1V | - |
| Bed width (Flumed) (m) | 10 | - |

Design (i) Drainage waterway (ii) Transitions. Also calculate the headloss through the siphon barrels assuming $f_2 = 0.0033$. Assume reasonable Mannings 'n' value for concrete.

BANGLADESH UNIVERSITY OF ENGINEERING AND TECHNOLOGY, DHAKA

L-4/T-2 B. Sc. Engineering Examinations 2012-2013

Sub : **CE 433** (Solid and Hazardous Waste Management)

Full Marks : 140

Time : 3 Hours

The figures in the margin indicate full marks.

USE SEPARATE SCRIPTS FOR EACH SECTION

SECTION – AThere are **FOUR** questions in this Section. Answer any **THREE**.

Arithmetic probability paper and probability paper attached.

1. (a) Explain, with diagram, the hierarchy of the Solid Waste Management approach. Cite appropriate reasons for setting such hierarchy. (5)
- (b) List the factors affecting the solid waste generation rates. Cite appropriate example. (5)
- (c) Solid wastes generated (yd^3/day) from a residential building at BUET were collected for 14 consecutive days as shown in the following table. (13 $\frac{1}{3}$)

| | | | | | | |
|--------|----------|--------|--------|---------|-----------|----------|
| Friday | Saturday | Sunday | Monday | Tuesday | Wednesday | Thursday |
| 22.2 | 6.8 | 1.0 | 6.6 | 12.6 | 10.4 | 17.0 |
| Friday | Saturday | Sunday | Monday | Tuesday | Wednesday | Thursday |
| 20.0 | 7.0 | 1.9 | 7.4 | 12.0 | 10.6 | 15.8 |

Plot the distribution on the appropriate probability paper and determine the type of distribution, mean, median, standard deviation, coefficient of variation, coefficient of skewness and coefficient of kurtosis. Also, predict how many days in a month the solid waste generation rate will be greater than $10\text{yd}^3/\text{day}$.

2. (a) Draw the schematic diagrams of the SCS and both the HCS systems. Identify the different activities on the diagrams. Also, define each of the terms for all these collection systems. (7)
- (b) A new residential area composed of 800 low-rise detached buildings is about to be occupied. Assuming that either two or three trips per day will be made to the disposal site, design the collection system and compare the alternatives. The following data are applicable. (16 $\frac{1}{3}$)
- Solid waste generation rate = $0.032 \text{ yd}^3/\text{day}/\text{home}$
 - Containers per service = 2
 - Type of service = 75% curbside and 25% rear of the house
 - Collection frequency = once per week
 - Collection vehicle is rear-loaded compactor with compaction ratio 2.5
 - Length of work day = 8 hrs
 - Collection crew = 2 persons
 - Round-trip haul distance = 20 miles
 - Haul constants: **a** = 0.08 hr/trip; **b** = 0.025 hr/mile
 - At-site time per trip = 0.083 hr/trip

(Use reasonable values for parameters not given).

CE 433

3. (a) The Chittagong City Corporation (CCC) has employed you to design the solid waste collection system for the city. What guidelines should you consider in laying out the collection routes for CCC? Also, identify the most important one and provide the reason behind your selection. (5)

(b) How and why the size reduction is done at Material Recovery Facilities (MRFs)? Explain, with diagram, the effect of size reduction on unprocessed residential and commercial solid wastes. (5)

(c) Determine the round-trip break-even time for solid waste collection systems in which 30 yd³ self-loading compactors used for collection are driven to the disposal site and compare that with using a transfer and transport system. Assume that the following data are applicable. (13 1/3)

(i) Specific weight of wastes in self-loading compactor = 600 lb/yd³

(ii) Specific weight of wastes in transport trailers = 325 lb/yd³

(iii) Volume of tractor-semitrailer transport unit = 105 yd³

(iv) Operational cost of self-loading compactor = \$40/hr

(v) Operational cost of tractor-semitrailer transport unit = \$60/hr

(vi) Transfer station operational costs including amortization = \$3.25/ton

(vii) Extra unloading time cost for transport units, compared with compactors = \$0.40/ton

(Use reasonable values for parameters not given)

4. (a) Draw the definition sketch for allocation of solid wastes from four transfer stations to three disposal sites. Write the objective function for cost minimization for the waste load allocation process for the above scenario. Enumerates the constraints along with the corresponding mathematical expression. (8)

(b) A community of 1200 homes cannot pay for the initial and operating cost of the recycling collection vehicles that were to be used. Instead, residents are to haul recycling containers to a drop-off center operated by the community. Calculate the number of vehicles from which recyclable materials must be unloaded per hour at the recycling drop-off center. Assume the center is open for eight hours per day, two days per week and that 40% of the residents will deliver recycling containers. Also, assume that 75% of the participants retake their separated materials to the drop-off center once per week and that the remaining 25% of the participants will bring their separated materials to the drop-off center once per two weeks. Do you think the drop-off center can handle the number of cars? If not, how do you plan to address the problem? (8)

(c) Following average speeds were obtained for various round-trip distances to a disposal site. Plot and find the haul speed constants **a** and **b** and the round trip haul time for a site that is located 15.0 miles away.

CE 433

Contd ... Q. No. 4(c)

| | | | | | | | |
|------------------------------------|----|----|----|----|----|----|----|
| Round trip distance (mile/trip) | 2 | 5 | 8 | 12 | 16 | 20 | 25 |
| Av. haul speed (mph) | 17 | 28 | 32 | 36 | 40 | 42 | 45 |

In your opinion what would be the best time to collect the data on the time required to travel to the disposal site to develop the above table for average haul speed? (7 1/3)

SECTION – B

There are **FOUR** questions in this Section. Answer any **THREE**.

5. (a) List the problems created by indiscriminate dumping of solid wastes. (5)
- (b) What are the main features of different landfill development levels in developing countries? (5)
- (c) Draw a neat sketch of the layout plan of a sanitary landfill site. (8 1/3)
- (d) Calculate the requirement landfill capacity for a community for the year 2040 from the following data: (5)

Projected population for the year 2040 = 50,00,000

Per capita waste generation rate = 5.6 lb/cap/d.

Diversion fraction = 0.20

Compacted waste density = 42.7 lb/ft³.

Assume a soil cover is used daily that accounts for 15% of the landfill volume.

6. (a) Define leachate. Deduce the spacing of laterals for leachate collection system of a landfill site. (7)
- (b) Summarize leachate treatment options. What are the important factors in the design of a leachate treatment system? (10 1/3)
- (c) The following three soil layers are lying between the base of a landfill and the underlying aquifer. How long will it take for leachate to migrate to the aquifer? Also calculate the amount of leachate flowing down if the landfill area is 75 hectare. (6)

| Soil layer | Depth (m) | Prosity (%) | Permeability (m/s) |
|------------|-----------|-------------|----------------------|
| Soil A | 2.55 | 43 | 5.3×10^{-8} |
| Soil B | 2.75 | 41 | 3.5×10^{-9} |
| Soil C | 3.25 | 42 | 2.8×10^{-7} |

7. (a) What are the potential environmental impacts of landfill gases? (7)
- (b) Sketch the idealistic development of landfill gases. (5)
- (c) What are the objectives of gas recovery from a sanitary landfill? Discuss briefly the gas recovery system. (5 1/3)

CE 433

Contd ... Q. No. 7

(d) Estimate the theoretical volume of methane and carbon-di-oxide gases that would be expected from the anaerobic digestion of a ton of a waste having the composition $C_{40}H_{90}O_{30}N_2$. Comment on the results obtained. Given : Density of CH_4 gas at STP = 0.7167 kg/m^3

Density of CO_2 gas at STP = 1.9783 kg/m^3 (6)

8. (a) Sketch the pathways of human exposure to hazardous wastes. (5)

(b) Draw a flow diagram for hazardous waste treatment and disposal facilities. (7)

(c) List the design consideration of a hazardous waste landfill. ($7\frac{1}{3}$)

(d) Briefly describe the management of Hospital wastes. (4)

The figures in the margin indicate full marks.

Assume reasonable values for missing data, if any.

USE SEPARATE SCRIPTS FOR EACH SECTION

SECTION – A

There are **FIVE** questions in this Section. Answer any **FOUR**.

1. (a) Name the different components of a steel-concrete composite beam. Show them in a neat sketch. (5)
- (b) For the composite floor system shown in Fig. 1 determine the ultimate moment capacity of the composite girder (W24 × 55). (12 ½)
- Given: For W24 × 55 beam section: depth = 23.6 inch, X-area = 16.2 in²
- Concrete strength = 4 ksi
- Steel Yield strength = 50 ksi
2. (a) Differentiate between: (5)
- (i) Full and partial interaction
- (ii) Shored and unshored construction
- (b) For the secondary beams (W18 × 35) shown in the floor system in Fig. 1, calculate the service load flexural stresses in concrete and steel of the composite section for shored construction. Draw the flexural stress distribution diagram across the depth of the composite beam and identify the stresses at the steel-concrete interface. (12 ½)
- Given:
- Live load = 100 psf
- Partition wall load = 80 psf
- Floor finish = 30 psf
- Miscellaneous dead load = 10 psf
- Concrete strength = 4 ksi
- Steel yield strength = 50 ksi
- Modulus of elasticity of concrete = 3,900 ksi
- Modulus of elasticity of steel = 30,000 ksi
- The connection between the secondary beams (W18 × 35) and the main girder (W24 × 55) is shear connection.
3. (a) What are the code specified limits for vertical deflections of composite beams in unshored construction. (5)

CE 413

Contd ... Q. No. 3

(b) Check whether the deflection of the composite beam, loaded as shown in Fig. 2, satisfies the code specified limits for vertical deflections. No shoring is used during the construction. Assume, 80% composite action achieved through shear connectors. If the deflection is greater than the code prescribe limits, what possible measures can be implemented to reduce the vertical deflection, without increasing the stiffness of the beam. (12 1/2)

4. (a) Why shear connectors are required in composite construction? Name three different types of shear connectors with neat sketches. (5)

(b) For the continuous composite beam shown in Fig. 3, calculate the no. of shear connectors required at mid-span and at or near support. (12 1/2)

Given:

Use $\frac{3}{4}$ " diameter, 3" length shear stud connectors

Allowable shear per connector is 12k

Concrete strength = 3 ksi

Steel yield strength = 36 ksi

5. (a) Draw a typical steel deck profile and show the code specified limits (minimum requirement) for rib width, rib height and thickness of concrete over the deck. (5)

(b) Find the yield capacity of the composite beam section shown in Fig. 3 in positive bending. Compare the yield capacity of the composite section with the yield capacity of the steel section only and provide your comments. (12 1/2)

SECTION – B

There are **FIVE** questions in this Section. Answer any **FOUR**.

6. (a) State the assumptions of plastic stress distribution method for predicting the capacity of composite columns. (4)

(b) A fully encased composite (FEC) column section is shown in Fig. 4. Check whether the provided section satisfies the code specified limits for (12 1/2)

(i) Concrete strength

(ii) Specified minimum yield stress of structural and reinforcing steel

(iii) Structural steel ratio

(iv) Maximum and minimum longitudinal reinforcement ratio

(v) Transverse Steel

Given: $F_y = F_{yr} = 50$ ksi, $f'_c = 5$ ksi, $E_s = 29,000$ ksi and $E_c = 3,900$ ksi.

(c) Check the adequacy of the section provided in Fig. 4 to resist the given compressive load. Use the data provided in 6(b) as required. (11)

CE 413

7. (a) Briefly discuss the advantages and disadvantages of fully encased composite columns. (4)

(b) Determine axial compressive and tensile strength of a 5.0 m pin ended FEC column with a size of 650 × 650 mm. The cross-section of the column is shown in Fig. 5. (13 ½)

Given: $F_y = F_{yr} = 350 \text{ MPa}$, $f'_c = 30 \text{ MPa}$, $E_s = 200 \text{ GPa}$ and $E_c = 30 \text{ GPa}$.

8. (a) State five advantages of steel-concrete composite construction over RCC and steel only construction. (4)

(b) For the fully encased composite column section shown in Fig. 5. Calculate the axial force and bending moment for balanced failure condition. Use the material properties provided in question 7(b). (13 ½)

9. (a) Discuss with neat sketches the different types of steel-concrete composite columns. (4)

(b) For the Fig. 6(a), determine the axial compressive strength of the concrete filled tubular column (CFT). Determine the diameter of the round concrete filled tube shown in Fig. 6(b) if it is to resist atleast the same factored compressive load as that of the rectangular CFT column. The concrete filled tube is to be designed as composite section.

Given: Pin-ended column with 15' length. (13 ½)

$f_y = 36 \text{ ksi}$, $f'_c = 4 \text{ ksi}$, $E_s = 30,000 \text{ ksi}$ and $E_c = 3400 \text{ ksi}$.

10. For the partially encased steel composite column cross section shown in Fig. 7, find (17 ½)

(a) The load P_b and the moment M_b corresponding to the balanced failure condition

(b) pure axial compressive load capacity

(c) pure axial tensile load capacity

(d) Draw the P-M diagram and find the pure nominal moment capacity.

Given: $F_y = 350 \text{ MPa}$, $f'_c = 30 \text{ MPa}$, $E_s = 200 \text{ GPa}$.

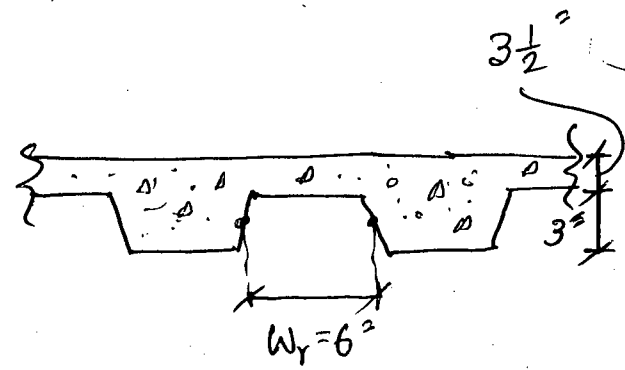
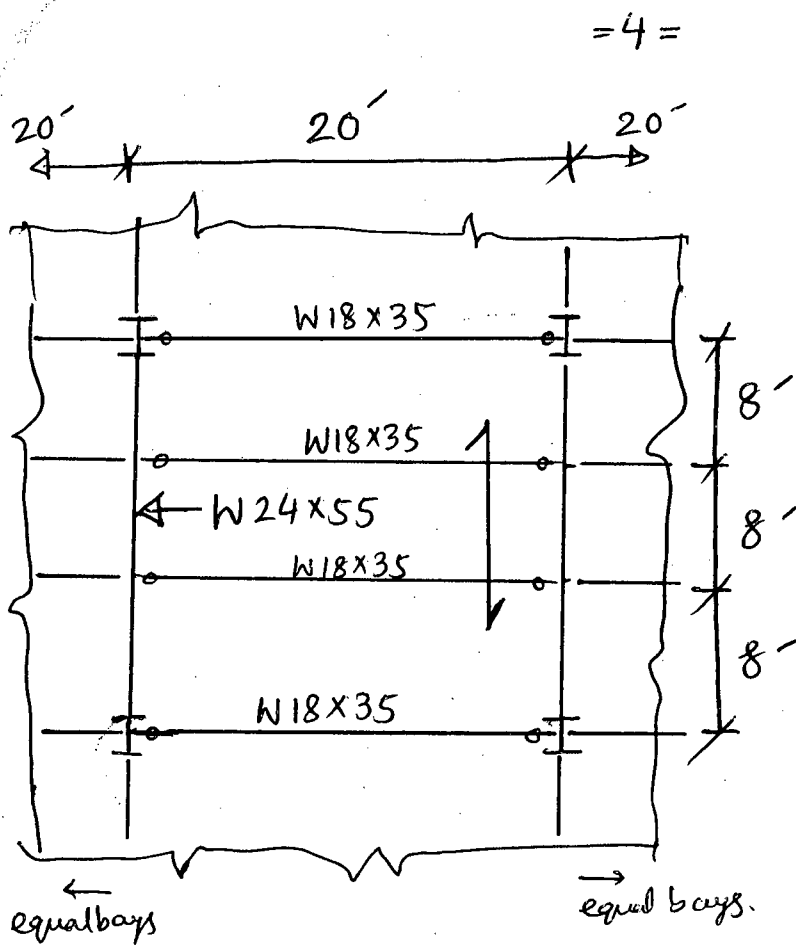

Fig. 1 (Questions 1(b) & 2(b))

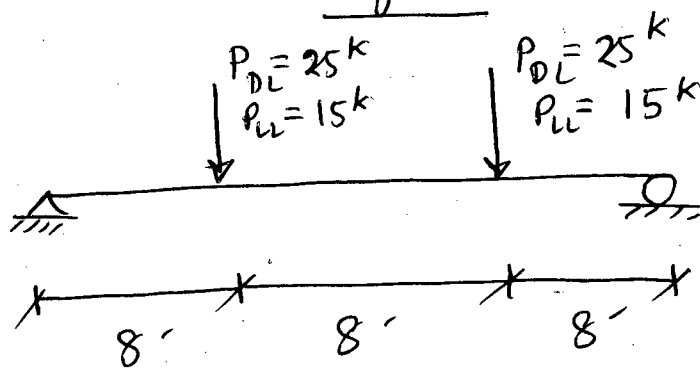
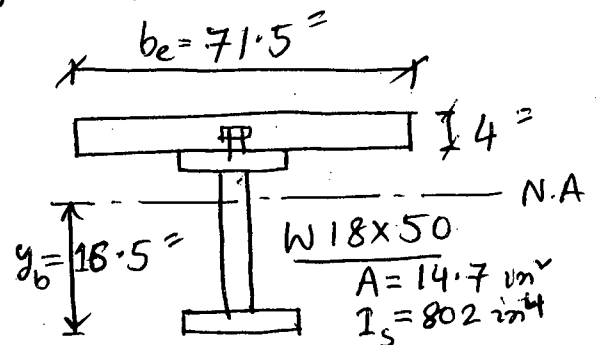

Fig. 2 (Question 3(b))



Composite beam section
 $S_{tr} = 125 \text{ in}^3$ (for bottom fibre)

$S_s = 89.1 \text{ in}^3$

$I_{tr} = 2060 \text{ in}^4$

Assume, 80% composite action.

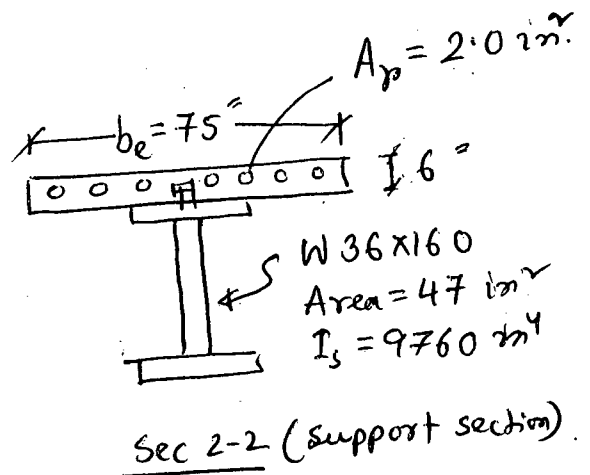
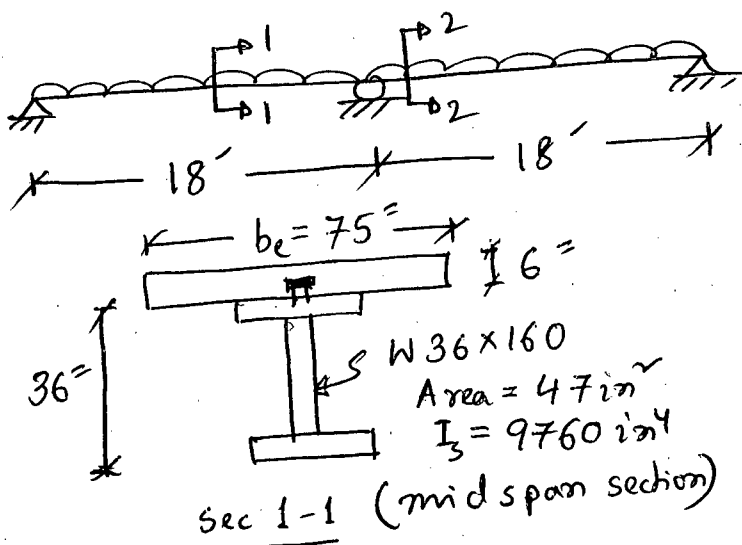

Fig. 3 (Questions 4(b) & 5(b)).

=5=

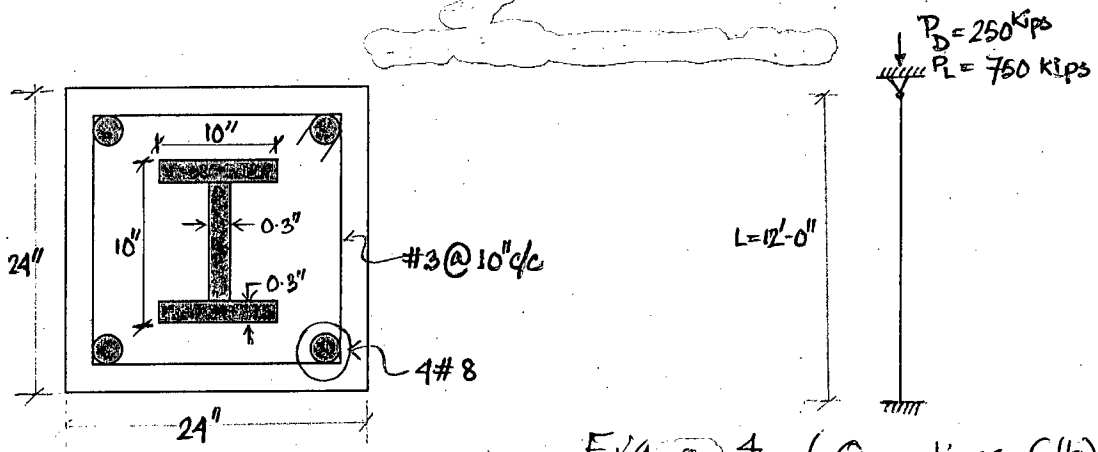

Fig 4 (Questions 6(b) & 6(c))

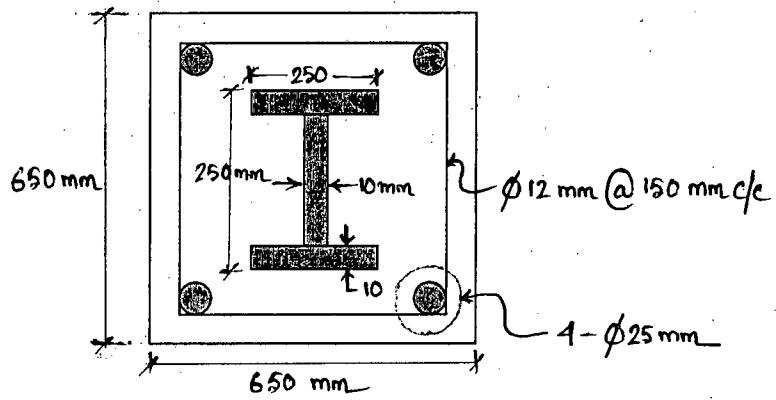

Fig 5 (Questions 7(b) & 8(b))

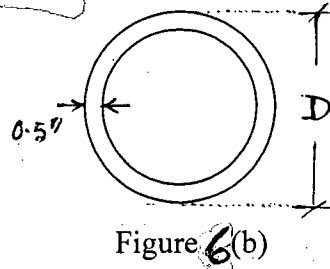
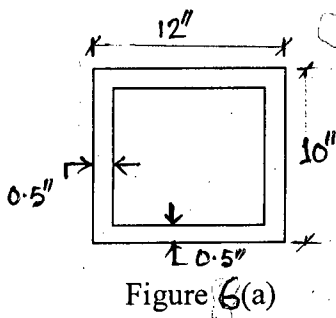

Fig 6 (Question 9(b))

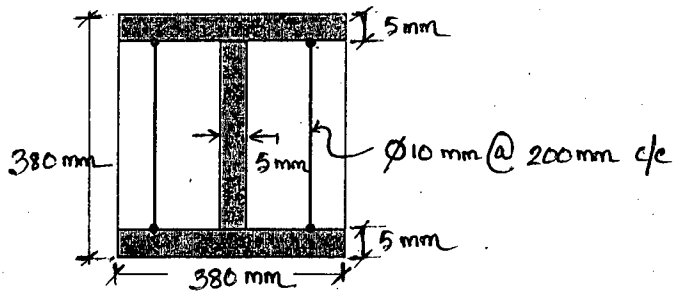

Fig 7 (Question 10)

= 6 =

CE 413

| TABLE I1.1A Limiting Width-to-Thickness Ratios for Compression Steel Elements in Composite Members Subject to Axial Compression For Use with Section I2.2 | | | | |
|--|--------------------------|---------------------------------------|---------------------------------------|-----------------------------|
| Description of Element | Width-to-Thickness Ratio | λ_p Compact/ Noncompact | λ_r Noncompact/ Slender | Maximum Permitted |
| Walls of Rectangular HSS and Boxes of Uniform Thickness | b/t | $2.26 \sqrt{\frac{E}{F_y}}$ | $3.00 \sqrt{\frac{E}{F_y}}$ | $5.00 \sqrt{\frac{E}{F_y}}$ |
| Round HSS | D/t | $\frac{0.15E}{F_y}$ | $\frac{0.19E}{F_y}$ | $\frac{0.31E}{F_y}$ |

(a) For compact sections

$$P_{no} = P_p$$

where

$$P_p = F_y A_s + C_2 f_c' \left(A_c + A_{sr} \frac{E_s}{E_c} \right)$$

$C_2 = 0.85$ for rectangular sections and 0.95 for round sections

(b) For noncompact sections

$$P_{no} = P_p - \frac{P_p - P_y}{(\lambda_r - \lambda_p)^2} (\lambda - \lambda_p)^2$$

where

λ , λ_p and λ_r are slenderness ratios determined from Table I1.1a
 P_y is determined from Equation I2-9b

$$P_y = F_y A_s + 0.7 f_c' \left(A_c + A_{sr} \frac{E_s}{E_c} \right)$$

(c) For slender sections

$$P_{no} = F_{cr} A_s + 0.7 f_c' \left(A_c + A_{sr} \frac{E_s}{E_c} \right)$$

where

(i) For rectangular filled sections

$$F_{cr} = \frac{9E_s}{\left(\frac{b}{t}\right)^2}$$

(ii) For round filled sections

$$F_{cr} = \frac{0.72F_y}{\left(\left(\frac{D}{t}\right)\frac{F_y}{E_s}\right)^{0.2}}$$

$$EI_{eff} = E_s I_s + E_s I_{sr} + C_3 E_c I_c$$

$$C_3 = 0.6 + 2 \left(\frac{A_s}{A_c + A_s} \right) \leq 0.9$$

$$\text{If } \dots \frac{P_{no}}{P_e} \leq 2.25 \quad P_n = P_{no} \left[0.658 \left(\frac{P_{no}}{P_e} \right) \right]$$

$$\text{Else } \dots \frac{P_{no}}{P_e} > 2.25 \quad P_n = 0.877 P_e$$

For FEC columns:

nominal compressive strength, $P_o = A_s F_y + A_{sr} F_{yr} + 0.85 A_c f'_c$

$$EI_{eff} = E_s I_{sy} + 0.5 E_s I_{sry} + C_1 E_c I_{cy}$$

$$C_1 = 0.1 + 2 \left(\frac{A_s}{A_c + A_s} \right) \leq 0.3$$

nominal tensile strength, $P_o = A_s F_y + A_{sr} F_{yr}$

For PEC Columns:

Axial Compressive Strength

$$C_r = (A_{se} F_y + 0.85 A_c f_{cu} + A_{sr} F_{yr})$$

$$A_{se} = (d - 2t + 2b_e) t$$

$$b_e = \frac{b_f}{(1 + \lambda_p^{2n})^{1/n}} \leq b_f \quad \boxed{n=1.5}$$

$$\lambda_p = \frac{b}{t} \sqrt{\frac{12(1 - \nu_s^2) F_y}{\pi^2 E_s k}}$$

$$k = \frac{0.9}{(s/b_f)^2} + 0.2(s/b_f)^2 + 0.75, \quad (0.5 \leq s/b_f \leq 1)$$

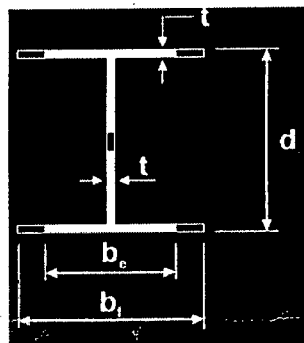

SECTION – A

There are **FOUR** questions in this Section. Answer any **THREE**.

1. (a) Explain the causes of braiding of a river with sketches, if necessary. (7)
- (b) Describe the general design considerations of an earthen levee. (8 1/3)
- (c) Explain the different causes of failure of a levee with sketches. (8)

2. (a) Classify river training works depending on its purpose with examples. (7 1/3)
- (b) Explain how channel improvement and soil conservation help to control flood. (7)
- (c) Calculate the water way, length of the guide banks, thickness of stone pitching and length of the falling apron of a revetment for the given data. Maximum discharge of the river is 12,000 cumecs and the corresponding water depth is 4.0 m. Mean diameter of sediment particle is 20 mm. Assume any other data if needed. (9)

3. (a) Describe different types of groynes with neat sketches. (7 1/3)
- (b) Describe different types of measures for sediment control in a reservoir. (3 1/2)
- (c) Write down the names of different types of dredger with their characteristics. (3 1/2)
- (d) Describe the following terms in brief with neat sketches. (3×3=9)
 - (i) Pitched Stone
 - (ii) Hard Points
 - (iii) Bottom Panels

4. (a) Describe different types of bed forms with neat sketches. (8 1/3)
- (b) Explain different types of sediment transport load. (3 1/2)
- (c) Explain the effects of bed forms on roughness with graph, if necessary. (3 1/2)
- (d) Describe different structural measures of flood control with their advantages and limitations. (8)

WRE 409(CE)

SECTION – B

There are **FOUR** questions in this Section. Answer any **THREE**.

5. (a) Classify river based on planform. (8)
- (b) Draw a simple flow diagram showing the 'forms and processes' involved in river flow. (10)
- (c) Write down the causes of meander development. (5 1/3)
6. (a) Discuss the behavior of alluvial river at the stage of flow at bends. (6)
- (b) What is a cutoff in meandering river? Explain the various conditions favorable for cutoff development. (12)
- (c) Draw a neat sketch of a regular meander path showing all elements. (5 1/3)
7. (a) Draw a typical cross section of a braiding river. (5 1/3)
- (b) Write short notes on (i) sinuosity, (ii) tortuosity (iii) channel with sand beds, and (iv) river delta. (10)
- (c) A meandering river is flowing with a discharge 40000 m³/s. Calculate meander length, meander width and meander ratio by Inglis and Leopold-Wolman theory. (8)
8. (a) Write down the salient characteristics of aggrading and degrading rivers. (8)
- (b) Show that for incipient motion of sediment, $\tau_0 = \gamma R S$; where all the symbols have their usual meaning. (8)
- (c) Sketch a typical Shield's diagram and mention its salient features. (7 1/3)
-

BANGLADESH UNIVERSITY OF ENGINEERING AND TECHNOLOGY, DHAKA

L-4/T-2 B. Sc. Engineering Examinations 2012-2013

Sub : **CE 435** (Environmental Pollution Management)

Full Marks : 140

Time : 3 Hours

The figures in the margin indicate full marks.

USE SEPARATE SCRIPTS FOR EACH SECTION

SECTION – A

There are **FOUR** questions in this Section. Answer any **THREE**.

1. (a) Identify the main reasons for high concentration of particular matter (PM) in Dhaka city's air during the dry season?

On a particular day, air quality data recorded at a CAMS in Dhaka are as follows:

$$PM_{2.5}(24\text{-hr}) = 185 \mu\text{g}/\text{m}^3$$

$$PM_{10}(24\text{-hr}) = 272 \mu\text{g}/\text{m}^3$$

$$O_3(8\text{-hr}) = 180 \mu\text{g}/\text{m}^3$$

$$SO_2(24\text{-hr}) = 120 \mu\text{g}/\text{m}^3$$

Determine AQI for each parameter and report AQI for that particular day.

(8)

[Given: $T = 24^\circ\text{C}$; $P = 1 \text{ atm}$; Table for calculating AQI provided]

- (b) Calculate the minimum size of particle that will be removed with 100% theoretical efficiency in a "settling chamber" of length 6.5 m and height 1.5 m, if the horizontal flow velocity is maintained at 0.25 m/sec. Also calculate the settling velocity for this particle size.

(7)

- (c) "Radiative forcing" (since pre-industrial time) of "Tropospheric ozone" is considered to be positive, while that of "Stratospheric ozone" is considered to be negative. Briefly explain why.

(3 1/3)

- (d) What are the important mechanisms for deposition of particulate matter (PM) in the respiratory system? Show with appropriate figures. Why deposition of PM in the "alveolar region" is particularly harmful? Explain.

(5)

2. (a) On a particular day, ambient atmospheric temperature profile is given by the following equations:

$$\begin{aligned} \Lambda(^{\circ}\text{C}) &= 30 - 0.02z && ; z \leq 50 \text{ m} \\ &= 29 && ; 50 < z \leq 100\text{m} \\ &= 29 - 0.01z && ; z > 100 \text{ m} \end{aligned}$$

Where, z = altitude in m.

Determine how (i.e., in which direction, and up to what height) a plume is expected to move if it is emitted under the following three conditions: (i) Plume emitted at a temperature of 28°C from the top of a 40 m stack; (ii) Plume emitted at a temperature of 29.5°C from the top of a 50 m stack; (iii) Plume emitted at a temperature of 29°C from the top of a 100 m stack.

(8)

CE 435

Contd ... Q. No. 2

- (b) Explain, with an appropriate figure, the effect of air-fuel ratio on automotive emissions of HC, CO and NO_x. How emissions of these constituents could be reduced through “combustion process control”? Explain. (8)
- (c) How do hydrocarbons affect the NO-NO₂-O₃ photochemical reaction sequence and help produce O₃ and other secondary pollutants? Explain. How do CO and SO₂ also contribute to the formation of O₃? Explain. (7 1/3)
3. (a) A power plant emits SO₂ at the rate of 75 g/se through a stack that has an effective height of 45 m. Estimate the concentration of SO₂ at the roof of a 6-storey building with a height of 20 m; the building is located 1.2 km down-wind and 0.2 km off the center-line of the plume. Consider wind speed at instrument height (10 m) to be 3.1 m/sec, and the atmosphere to be “neutral”. (10)
- [Given: p = 0.25; Table for calculation of dispersion coefficient provided]
- (b) Explain, with appropriate examples, the different types of “radiative forcings”. How do atmospheric aerosols, including black carbon (BC) affect global warming? Explain. (8 1/3)
- (c) What are the major sources of carbon monoxide (CO) in the atmosphere? Explain the adverse health impacts of CO. (5)
4. (a) On a particular day, cars are traveling along a highway at 55 km/hour, and average distance between cars is 15 m. Each car is emitting carbon monoxide (CO) at a rate of 5.9 g/km. If wind speed is 2.5 m/sec. perpendicular to the road, estimate CO concentrations at 0.75 km downwind at a height of 9m for two different atmospheric stability conditions: (i) “stable”, and (ii) “very unstable”. Compare and comment on the two results. [Table for calculation of dispersion coefficient provided]. (10)
- (b) What do you understand by “stable”, “unstable” and “neutral” atmosphere? Draw the idealized shapes of “fumigating”, “lofting” and “fanning” plumes, along with the corresponding atmospheric temperature profiles (adiabatic and ambient). (5 1/3)
- (c) Starting from the burning of sulfur containing materials, explain the process of formation of sulfate particles in the atmosphere. How do SO_x affect building materials? Explain. (5)
- (d) Flow rate of exhaust gas from the stack of a 250 MW combined cycle power plant is 475 kg/sec. The estimated maximum concentration of SO₂ in the exhaust gas is 12 ppmv. Estimate SO₂ emission rate from the power plant in “g SO₂/sec”. [Given: MW of Exhaust Gas = 28.01 g/mol; assume reasonable values for parameters not given] (3)

CE 435

SECTION – B

There are **FOUR** questions in this Section. Answer Q. No. 5 and any **TWO** from the rest.

Q. No. 5 is compulsory.

5. (a) During dry season, the wastewater in Begunbari Khal has an ultimate CBOD of 1000 mg/L which is discharged into Norai Khal at a rate of $2.0 \text{ m}^3/\text{sec}$. Norai Khal has an ultimate CBOD of 10 mg/L just upstream of the discharge and is flowing at a rate of $8.0 \text{ m}^3/\text{sec}$. The average velocity in Norai Khal is 10 km/day. Assuming a reaction rate coefficient of 0.1 day^{-1} , calculate the ultimate and 5-day CBOD of the Norai Khal water immediately after the discharge ($x = 0 \text{ km}$) and 30 km downstream:

Also assume instantaneous complete mixing at the point of discharge.

(10)

- (b) The river Balu flowing at a velocity of 10 km/day has a dissolved oxygen content of 5.0 mg/L and an ultimate CBOD of 25 mg/L at distance $x = 0 \text{ km}$, i.e., immediately downstream of discharge from Norai Khal. The flow carried by Norai Khal has a CBOD decay co-efficient, k_d , of 0.2 day^{-1} . The river has a reaction rate co-efficient, k_r , of 0.4 day^{-1} , and a saturation DO concentration of 9.0 mg/L.

(14)

- (i) What is the initial DO deficit?
- (ii) Determine the location of the critical point, in time and distance.
- (iii) What is the DO level at the critical point?
- (iv) Is aquatic life safe in Balu river?

6. (a) Explain briefly the processes of 'bio-accumulation' and 'bio-magnification' of toxic pollutants in an aquatic food chain.

(6)

- (b) A large river has a reaction rate constant of 0.4 day^{-1} , a velocity of 0.85 m/sec, and is saturated with oxygen at 10 mg/L ($D_0 = 0$) just upstream of a waste discharge point. Immediately downstream of the discharge, the ultimate demand for oxygen is found to be 20 mg/L and the deoxygenation rate constant is 0.2 day^{-1} . What is the dissolved oxygen level at a distance 48.0 km downstream of discharge?

(8)

- (c) Referring to problem in 6(b), suppose the waste stream has a DO concentration of 1.5 mg/L, a flow rate of $0.5 \text{ m}^3/\text{sec}$, a temperature of 26°C , and an ultimate BOD of 48 mg/L. The river is flowing at $2.2 \text{ m}^3/\text{sec}$ at a saturated DO concentration of 10.8 mg/L, at a temperature of 12°C , and an ultimate BOD of 13.6 mg/L.

(9)

Calculate the DO concentration 48.0 km downstream of discharge.

(Use, where necessary, $DO_{\text{sat}} = 14.62 - 0.394 T + 0.007714 T^2 - 0.0000646 T^3$ where T is temperature in $^\circ\text{C}$)

CE 435

7. (a) Distinguish between 'bio-degradable', 'non-degradable' and 'biologically accumulative' pollutants that enter the water environment. Give examples of each. **(11)**
- (b) Discuss the sources and effects of **(12)**
- (i) oxygen demanding wastes,
 - (ii) persistent organic pollutants, and
 - (iii) thermal wastes
- in water.
8. (a) Classify lakes according to the degree of enrichment with nutrients and organic matter. What is eutrophication? What important factors control the eutrophication process of lakes? Briefly discuss. **(12)**
- (b) Discuss briefly, how the processes of eutrophication and thermal stratification affect the quality of water in lakes. What management strategies should be considered for minimizing lake water quality problem? **(11)**
-

= 5 =

Table for calculation of AQI [for Question No. 1(a)]

| Breakpoints | | | | | | | AQI |
|------------------------------|----------------------------------|---|--|------------------|--------------------------------|---------------------------------|---------|
| O ₃ (ppm) 8-hr | O ₃ (ppm) 1-hr (i) | PM _{2.5} (µg/m ³) 24-hr | PM ₁₀ (µg/m ³) 24-hr | CO (ppm) 8-hr | SO ₂ (ppm) 24-hr | NO ₂ (ppm) Annual | |
| 0.000-0.064 | -- | 0.0-15.4 | 0-54 | 0.0-4.4 | 0.000-0.034 | (ii) | 0-50 |
| 0.065-0.084 | -- | 15.5-40.4 | 55-154 | 4.5-9.4 | 0.035-0.144 | (ii) | 51-100 |
| 0.085-0.104 | 0.125-0.164 | 40.5-65.4 | 155-254 | 9.5-12.4 | 0.145-0.224 | (ii) | 101-150 |
| 0.105-0.124 | 0.165-0.204 | 65.5-150.4 | 255-354 | 12.5-15.4 | 0.225-0.304 | (ii) | 151-200 |
| 0.125-0.374 | 0.205-0.404 | 150.5-250.4 | 355-424 | 15.5-30.4 | 0.305-0.604 | 0.65-1.24 | 201-300 |
| (iii) | 0.405-0.504 | 250.5-350.4 | 425-504 | 30.5-40.4 | 0.605-0.804 | 1.25-1.64 | 301-400 |
| (iii) | 0.505-0.604 | 350.5-500.4 | 505-604 | 40.5-50.4 | 0.805-1.004 | 1.65-2.04 | 401-500 |

- (i) In some cases, in addition to calculating the 8-hr ozone index, the 1-hr ozone index may be calculated, and the maximum of the two values reported
- (ii) NO₂ has no short-term air quality standard and can generate an AQI only above 200
- (iii) 8-hr O₃ values do not define higher AQI values (≥301). AQI values of 301 or higher are calculated with 1-hr O₃ concentrations

Table for estimation of dispersion coefficients [for Questions 3(a) and 4(a)]

| Stability | a | x ≤ 1 km | | | x ≥ 1 km | | |
|-----------|------|----------|-------|-------|----------|-------|-------|
| | | c | d | f | c | d | f |
| A | 213 | 440.8 | 1.941 | 9.27 | 459.7 | 2.094 | -9.6 |
| B | 156 | 106.6 | 1.149 | 3.3 | 108.2 | 1.098 | 2.0 |
| C | 104 | 61.0 | 0.911 | 0 | 61.0 | 0.911 | 0 |
| D | 68 | 33.2 | 0.725 | -1.7 | 44.5 | 0.516 | -13.0 |
| E | 50.5 | 22.8 | 0.678 | -1.3 | 55.4 | 0.305 | -34.0 |
| F | 34 | 14.35 | 0.740 | -0.35 | 62.6 | 0.180 | -48.6 |

^a The computed values of σ will be in meters when x is given in kilometers.

$$\sigma_y = a \cdot x^{0.894}$$

$$\sigma_z = c \cdot x^d + f$$

SECTION – A

There are **FOUR** questions in this Section. Answer any **THREE**.

1. (a) Define environmental policy. What are the guiding principles of environmental policy? (8)
- (b) What documents and information need to be submitted to the Department of Environment for environmental clearance certificate for the following categories of projects (i) “Green” (ii) “Orange A” and (iii) “Red” (9)
- (c) What is the difference between guidelines and standards? Give examples. (6 ⅓)

2. (a) What are the limitations of Environmental Conservation Rules (ECR) 1997 with respect to the standards incorporated therein and how the standards were set? What are the powers and functions of the Director General of DoE as per ECA1995? (8 ⅓)
- (b) Summarize the mitigation measures suggested for the following environmental impacts for the implementation of the Jamuna Multipurpose Bridge Project: (15)
 - (i) Disruption of river navigation
 - (ii) Dredged spoils disposal
 - (iii) Noise pollution
 - (iv) Transmission of diseases among workers
 - (v) Disruption of agricultural practices

In the Jamuna Multipurpose Bridge Project, what were the positive and negative impacts due to the closure of the northern intake of Dhaleswari River?

3. (a) What are merits and demerits of public consultation in the EIA process? (4 ⅓)
- (b) Answer the following questions regarding the Environmental Management Plan (EMP) (11)
 - (i) Who prepares the EMP?
 - (ii) How would one decide whether to prepare a single EMP or multiple EMPs?
 - (iii) Who oversees the implementation of the EMP?
 - (iv) How can the adoption of EMP by the Contractor be ensured?
 - (v) What are the typical contents of an EMP report?
- (c) State the jurisdiction of the Environment Court as per Environment Court Act. What are the guiding legislations of the Environment Court? What are the reasons for non-enforcement of the environmental laws in Bangladesh? (8)

CE 437

4. (a) Draw a schematic diagram showing the interaction of economic activities (production and consumption) with the natural environment. How can the residuals from production and consumption process be minimized? What are external benefits and how does it affect the socially efficient rate of output? (9)

(b) Explain 'efficient level of emissions' using Marginal Damage (MD) and Marginal Abatement Cost (MAC) curves. Show graphically what would be the effect on the 'efficient level of emission' if there is (i) an increase in population and (ii) adoption of improved technology in reducing emissions. (6 1/3)

(c) From the data below determine how much emission each plant has to reduce, if the total emission reduction of 10 ton/week is to be achieved at the minimum possible total cost. (8)

| Emission (tins/week) | Marginal Abatement Cost (lakh BDT/week) | |
|----------------------|---|---------|
| | Plant A | Plant B |
| 10 | 0 | 0 |
| 9 | 1 | 2 |
| 8 | 2 | 3 |
| 7 | 3 | 4 |
| 6 | 4 | 6 |
| 5 | 5 | 8 |
| 4 | 6 | 12 |
| 3 | 10 | 20 |
| 2 | 15 | 40 |
| 1 | 25 | 90 |
| 0 | 50 | 200 |

SECTION – B

There are **FOUR** questions in this Section. Answer any **THREE**.

5. (a) Explain with examples how is Environment and Development linked? How can you estimate the human carrying capacity of a country? Bangladesh is a developing country. It is a small country with huge population and limited resources. Make some suggestions to improve its carrying capacity. (12 1/3)

(b) What are the goals of Sustainable Development? How can you achieve those? Why is Ecological Footprint considered as a Sustainability Indicator? Explain. (11)

6. (a) State the objectives of Millennium Development Goals (MDGs). What are the targets to be achieved to ensure Environmental Sustainability in MDG? Do you think, Bangladesh is doing enough to achieve these targets? Justify your answer. (11 1/3)

(b) Describe one global environmental problem. In your opinion which environmental issue should be given utmost priority in Bangladesh's context. Explain in favour of your answer. (12)

CE 437

7. (a) How does the Industrial Processes interact with Environment? Show with diagram.
How can you minimize those impacts? Describe briefly. **(12 1/3)**
- (b) What are the environmental implications of development in Tourism Sector? Describe briefly. **(11)**
8. (a) Why do we need different types of EIA methodologies? Differentiate between Matrix and EES method. **(11 1/3)**
- (b) Write short notes on (i) 4R Policy (ii) Biodiversity Conservation (iii) Green Development. **(12)**
-

BANGLADESH UNIVERSITY OF ENGINEERING AND TECHNOLOGY, DHAKA

L-4/T-2 B. Sc. Engineering Examinations 2012-2013

Sub : **CE 417** (Design of Concrete Structure III)

Full Marks : 140

Time : 3 Hours

The figures in the margin indicate full marks.

USE SEPARATE SCRIPTS FOR EACH SECTION

SECTION – AThere are **FOUR** questions in this Section. Answer any **THREE**.

Assume reasonable values for any data not provided.

1. (a) Differentiate between equilibrium and compatibility torsion. (3^{1/3})
 (b) Determine the necessary web and longitudinal reinforcement for the rectangular section shown in Fig. 1. The section is subjected to a factored shear $V_u = 48k$ and an equilibrium torsion $T_u = 360 k\text{-in.}$ at a section located at a distance 'd' from the face of the support. Use normal weight concrete with $f'_c = 4 \text{ ksi}$, $f_y = 60 \text{ ksi}$. (20)

2. (a) What are the ACI Code provisions for beams and columns in an 'Intermediate Moment Resisting frame.' (8)
 (b) A 14 in. wide by 22 in. deep reinforced concrete beam supporting a 5" thick slab spans between two interior columns in a building frame designed for a region of high seismic risk. The clear span is 22 ft. and reinforcement at the face of the support consists of four # 9 top bars and four # 8 bottom bars. The effective depth is 19.5 in. for both top and bottom steel. The maximum factored shear is 30 kips at each end of the beam. Material strength are $f'_c = 5000 \text{ psi}$, $f_y = 60,000 \text{ psi}$. Design the shear reinforcement for the regions adjacent to the column force. Consider effective flange width as 75". (15^{1/3})

3. Design interior panel of a waffle slab system shown in shown in Fig. 2. Considering following data: (23^{1/3})
 Span (c/c of column) = 36 ft.
 Width of rib = 6 in. (36 in. c/c spacing)
 Depth of rib = 14 in;
 Slab thickness = 3"
 Column size = 24" × 24"
 Dead load (excluding self weight) = 50 psf.
 Live load = 80 psf,
 $f'_c = 5 \text{ ksi}$, $f_y = 60 \text{ ksi}$.
 30" × 30" pan is used for casting.
 Volume = 6.54 cft/pan for 3" top slab and 14" rib depth.
 Moment factor (%) for column strip is 60 and 75 for positive and negative moment respectively.

CE 417

4. (a) The exterior joint shown in Fig. 3 is part of a continuous monolithic reinforced concrete frame designed to resist gravity load only. Member section dimension ($b \times h$) and reinforcement are shown. The frame storey height is 10 ft. Material strength: (13)

$$f'_c = 3,500 \text{ psi}, f_y = 60,000 \text{ psi.}$$

Design the joint for development length and shear. Given:

$$ldh = \left(\frac{0.02\psi_e f_y}{\lambda \sqrt{f'_c}} \right) d_b \quad \begin{array}{l} \psi_e = 1.0 \\ \lambda = 1.0 \\ \gamma = 20 \end{array}$$

- (b) A coupling beam has a span of 7 ft and a depth of 4 ft. Its width is 10 inch. What should be the maximum moment capacity and corresponding steel for this beam as per code? Given $f'_c = 4 \text{ ksi}$ and $f_y = 60 \text{ ksi}$. Assume all other data reasonably. Draw qualitative ideal arrangement for the steel placement in a coupling beam. (10 1/3)

SECTION – B

There are **FOUR** questions in this Section. Answer any **THREE**.

5. (a) What are the possible failure modes of shear wall? (3)
- (b) A three-story wall is subjected to factored wind forces as shown in Fig. 4. The wall is 12 ft long and 10 in thick. Design reinforcement for wall at the first level between base and second floor. Given: $f'_c = 3 \text{ ksi}$, $f_y = 60 \text{ ksi}$. (20 1/3)
6. (a) Write notes on general guide for choosing an adequate and economic floor system considering live load and span. (4)
- (b) Design the slab and an interior rib of a one-way concrete joist floor system shown in Fig. 5 having following descriptions: (19 1/3)
- Span of rib = 22 ft (simply supported)
- Dead load excluding self-weight = 20 psf
- Live load = 100 psf; $f'_c = 4 \text{ ksi}$, $f_y = 60 \text{ ksi}$.
7. The exterior joint shown in Fig. 6 is part of a reinforced concrete frame designed to resist earthquake loads. A 6 in slab (not shown) is reinforced with No.4 bars spaced 6 in center to center at the same level as the flexural steel in the beams. The member section dimensions and reinforcement are as shown. The frame storey height is 12 ft. Material strength are $f'_c = 4 \text{ ksi}$ and $f_y = 60 \text{ ksi}$. The maximum factored axial load on the upper column is 1400 kips and on the lower column is 1525 kips. Check if the nominal flexural strengths of the columns exceed those of the beams by at least 20%. Determine the minimum transverse reinforcement required over the length l_o in the column. (23 1/3)
8. A column bracket shown in Fig. 7 is to be designed to carry the end reaction of a girder. Vertical reaction from service dead and live load are 25 and 51 kips respectively applied at a point shown in figure. Select appropriate concrete dimensions, and design and detail all reinforcement. Given: $f'_c = 5 \text{ ksi}$, $f_y = 60 \text{ ksi}$. (23 1/3)

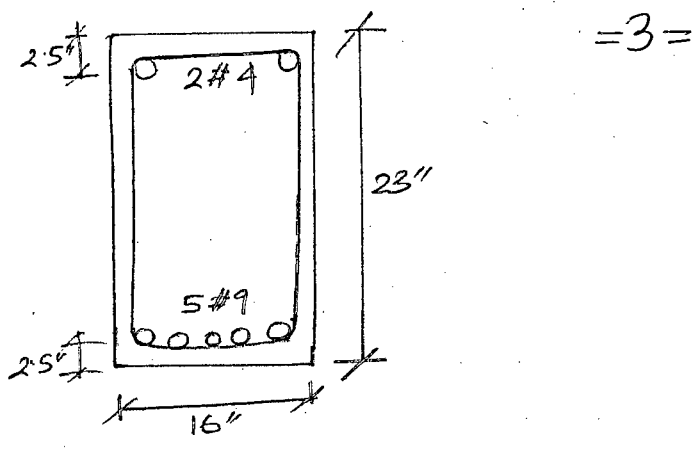

Fig. 1.

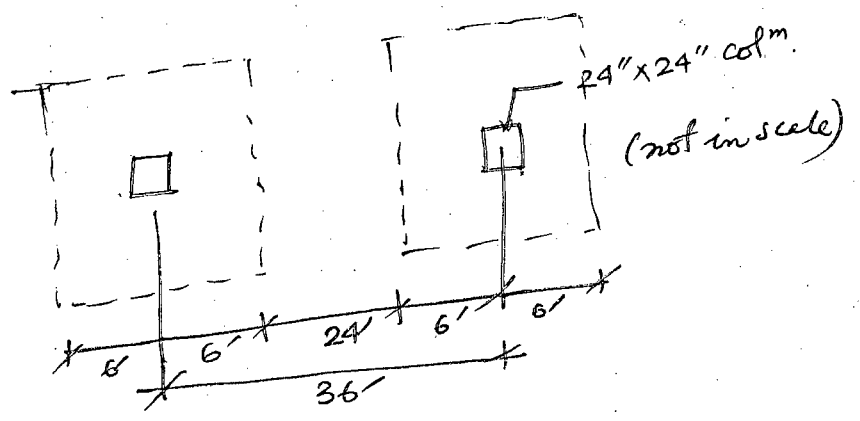
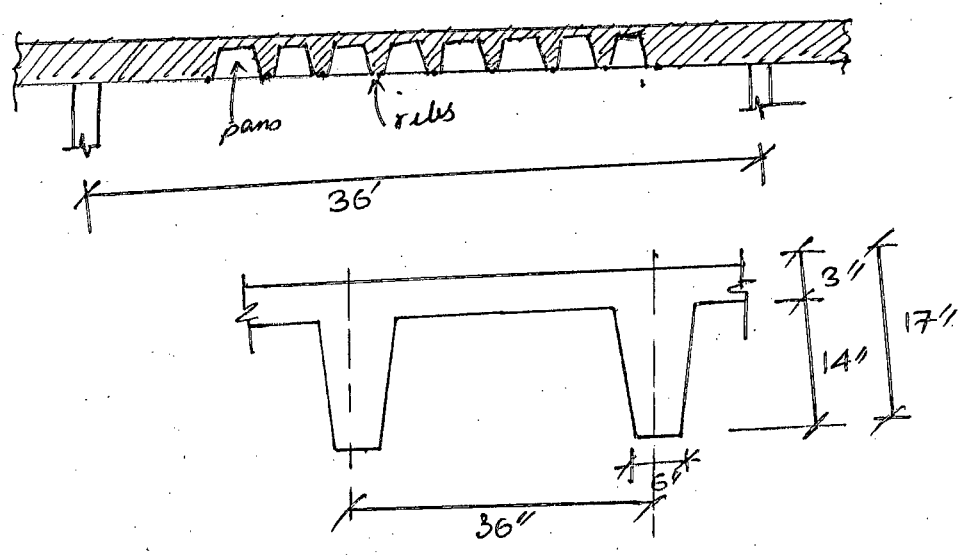

Fig. 2.

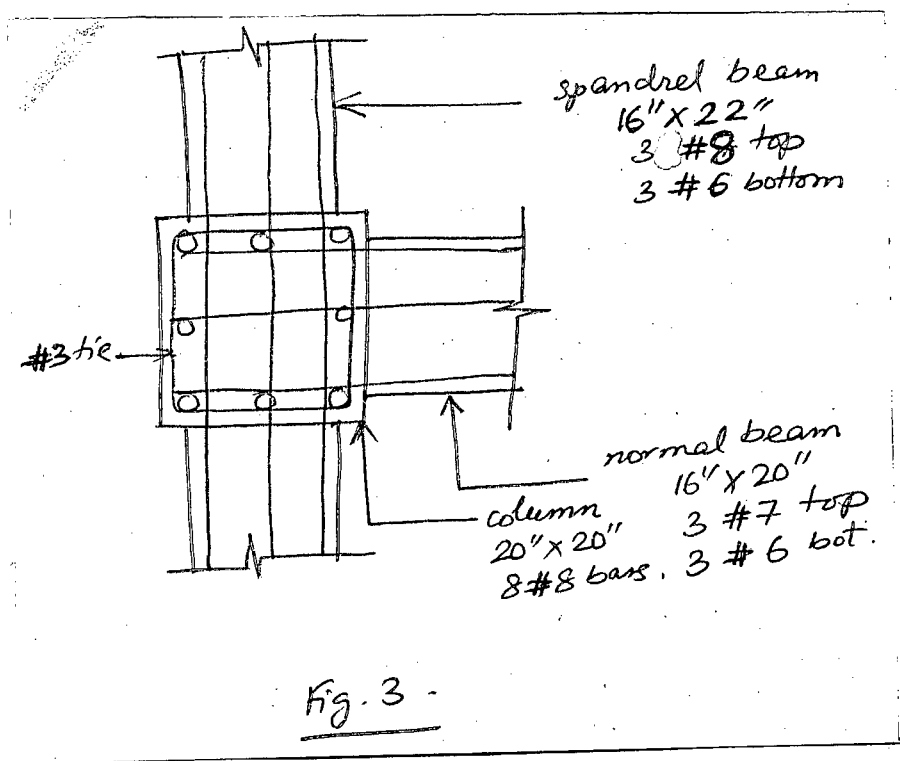
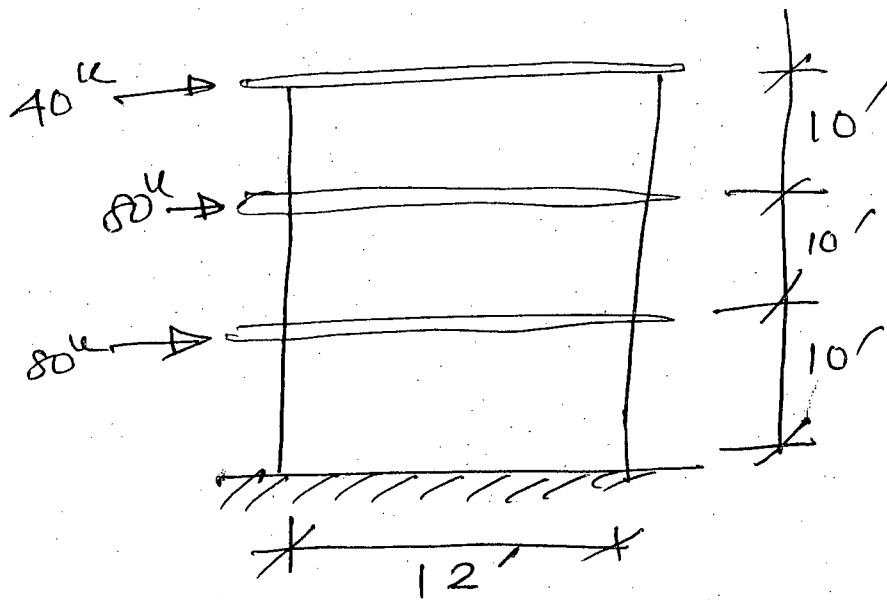

Fig. 3.

=4=



$$\frac{z}{lw} = \frac{1}{(2 + 0.85\beta_1 lw h f'_c / A_s S_y)}$$

$$\beta_1 = 0.85$$

Fig. 424

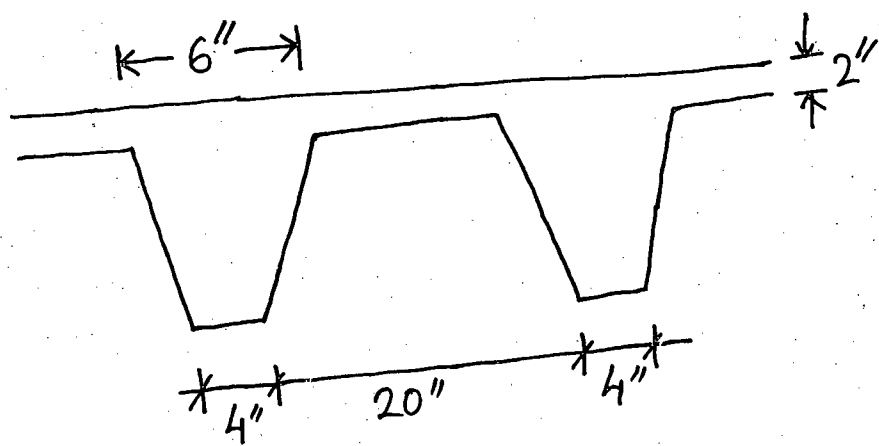

Fig. 535



=5=

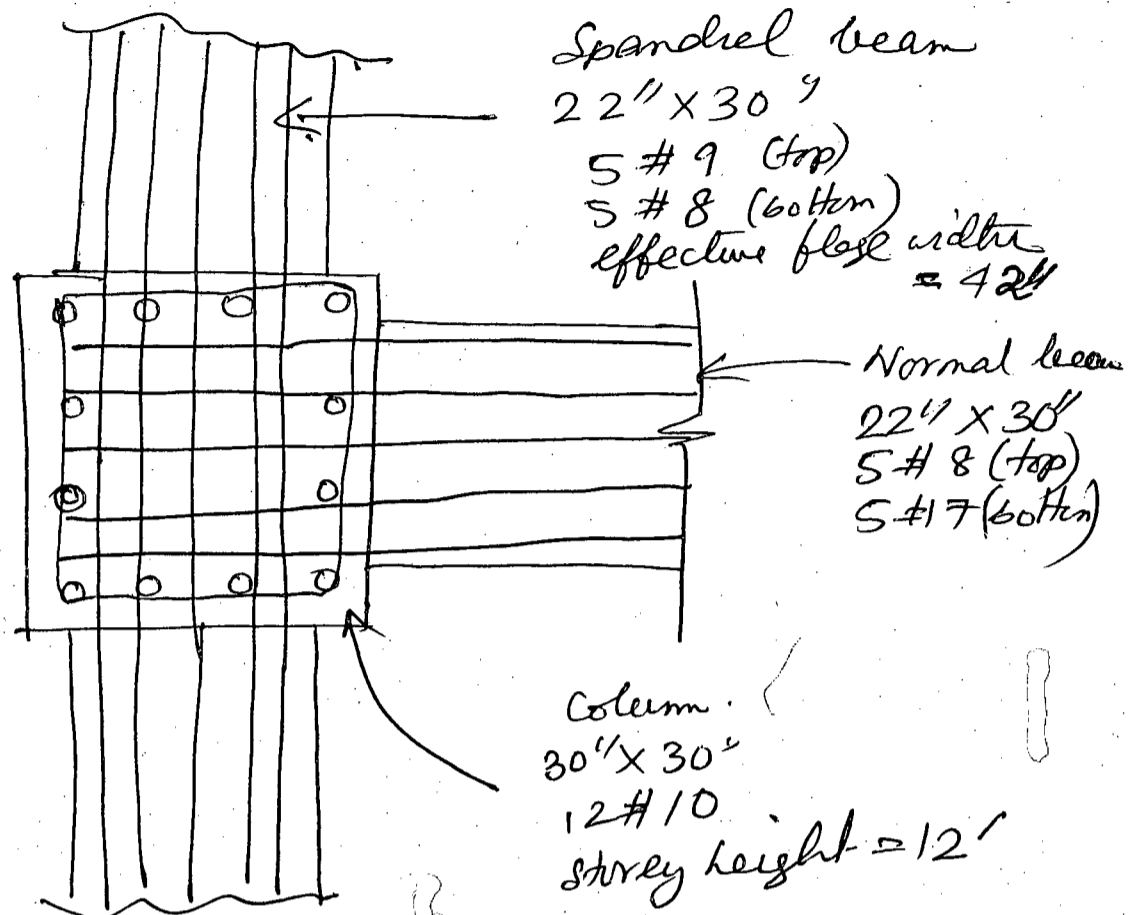

Fig. 6

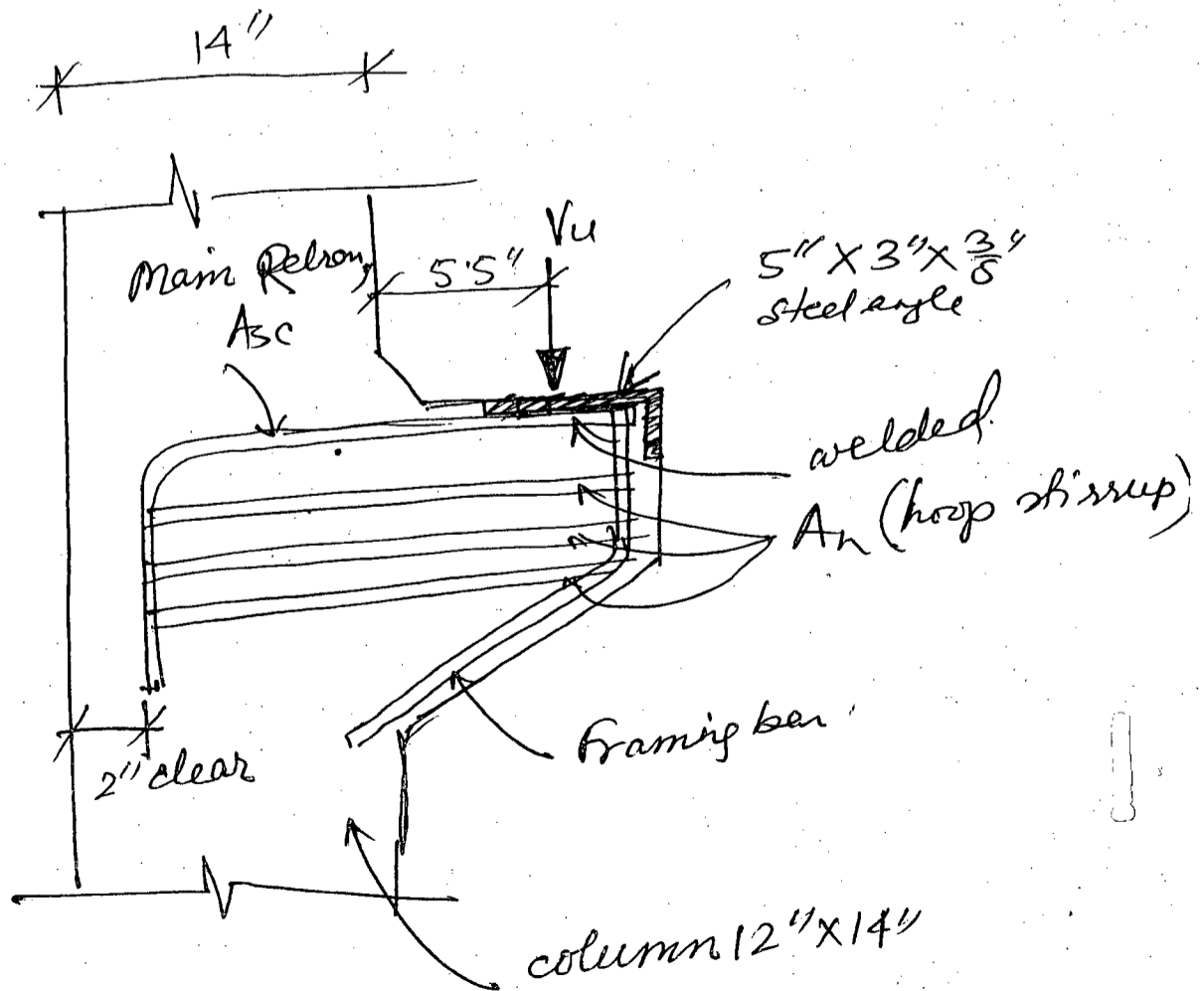
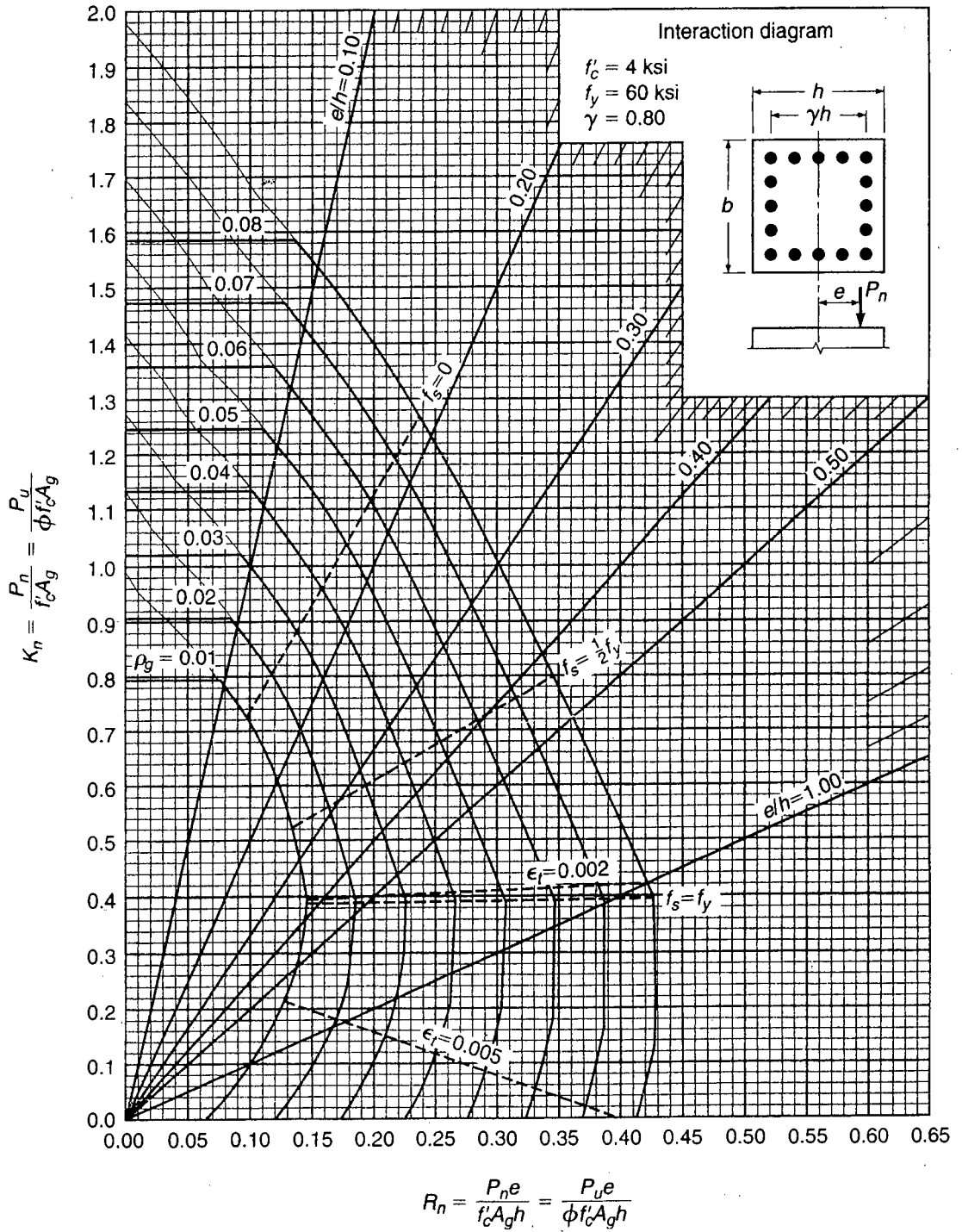

Fig. 7

= 6 =



GRAPH A.7

Column strength interaction diagram for rectangular section with bars on four faces and $\gamma = 0.80$.

BANGLADESH UNIVERSITY OF ENGINEERING AND TECHNOLOGY, DHAKA

L-4/T-2 B. Sc. Engineering Examinations 2012-2013

Sub : **CE 419** (Introduction to Finite Element Method)

Full Marks : 140

Time : 3 Hours

The figures in the margin indicate full marks.

The symbols have their usual meaning. Assume reasonable values for missing data if any.

USE SEPARATE SCRIPTS FOR EACH SECTION

SECTION – AThere are **FOUR** questions in this Section. Answer any **THREE**.

1. (a) Summarize the basic procedural steps that are followed in analyzing a structure using finite element method. (6)
- (b) When there are several FEM packages are available, is there any need to study this method? Discuss. (5)
- (c) State two problems where classical solutions will yield poorer results than FEM solutions. (4)
- (d) Approximate the area of a circle by dividing it into a number of triangles. In this process show that $S_N = \pi R^2$ when $N \rightarrow \infty$. Where, R = radius of the circle, N = number of triangles, S_N = Area of the circle. ($8\frac{1}{3}$)
2. (a) Write down the basic assumptions of linear static analysis. (6)
- (b) Find the stresses in the two bar assembly as shown in Figure 1. The bar is loaded with force P , and constrained at two ends. Use 1-D bar elements. (12)

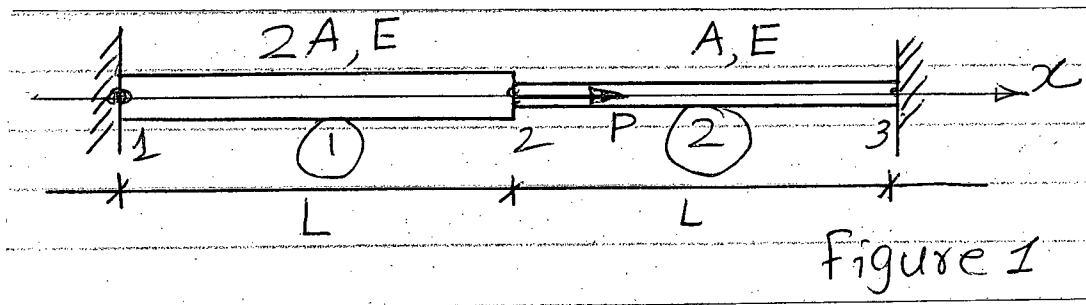

- (c) If the two bars in Figure 1 are tapered in cross-sectional area, how will you model the problem in FEM? ($5\frac{1}{3}$)
3. (a) Explain the terms 'Plane stress' and 'Plane strain' problems. Give constitutive laws for these cases. (4+4)
- (b) What is the difference between (i) Isotropic material, (ii) Orthotropic material in terms of mathematical description in FEM. ($4\frac{1}{3}$)
- (c) Explain the terms: (9)
 - (i) Constant Strain triangle (CST)
 - (ii) Linear strain triangle (LST)
 - (iii) Quadratic strain triangle (QST)

CE 419**Contd ... Q. No. 3**

- (d) Define (i) Local coordinate system (ii) Natural Coordinate system with neat sketches. (2)
4. (a) Introduce and explain isoparametric concept in finite element analysis. (5)
- (b) State three basic theorem on which isoparametric concept is developed. (6)
- (c) Discuss convergence criteria for isoparametric elements. (6 1/3)
- (d) Explain the following terms: (6)
- (i) Sub parametric element
- (ii) Super parametric element

SECTION – B

There are **FOUR** questions in this Section. Answer any **THREE**.

5. (a) Explain the term 'shape functions'. Why polynomial terms are preferred for shape functions? (6)
- (b) Assume reasonable shape functions and derive the strain displacement matrix (B) and element stiffness matrix (K) for the simple beam shown in Figure 2. The beam has a moment and a shear force at each of the ends. (10)
- (c) Including axial stiffness of a bar element, write down the stiffness matrix for general 2D beam element. (7 1/3)
6. (a) Write short notes on (8)
- (i) Jacobian matrix
- (ii) Gaussian quadrature integration technique
- (b) "In a displacement type finite element formulation with inadequately defined mesh, a lower bound solution is expected" Explain. (7 1/3)
- (c) Assemble Jacobian matrix and strain displacement matrix corresponding to Gauss point (0.57735, 0.57735) for the element shown in Figure 3. Also indicate how do you proceed to assemble the element stiffness matrix. (8)
7. (a) Determine shape functions for 4-noded rectangular elements. Use natural coordinate system. In this process show that shape function for i_{th} node can be written generally as: (13 1/3)

$$N_i = \frac{1}{4}(1 + \xi\xi_i)(1 + \eta\eta_i) \text{ for } i = 1, 2, 3 \text{ and } 4.$$

- (b) The beam shown in Figure 4 is clamped at the two ends and acted upon by a force P and moment M in the mid span. Find the deflection and rotation at the central node (Node No. 2) and reaction forces at the two ends (Node No. 1 and 3). (10)
8. (a) The spring system shown in Figure 5 contains arbitrarily numbered nodes and elements. Find the global stiffness matrix. (12)
- (b) Write a short note on the effect of element aspect ratio on the accuracy of the solution. (5 1/3)
- (c) Discuss the various discontinuities to be considered in discretizing a structure in FEM. (6)

= 3 =

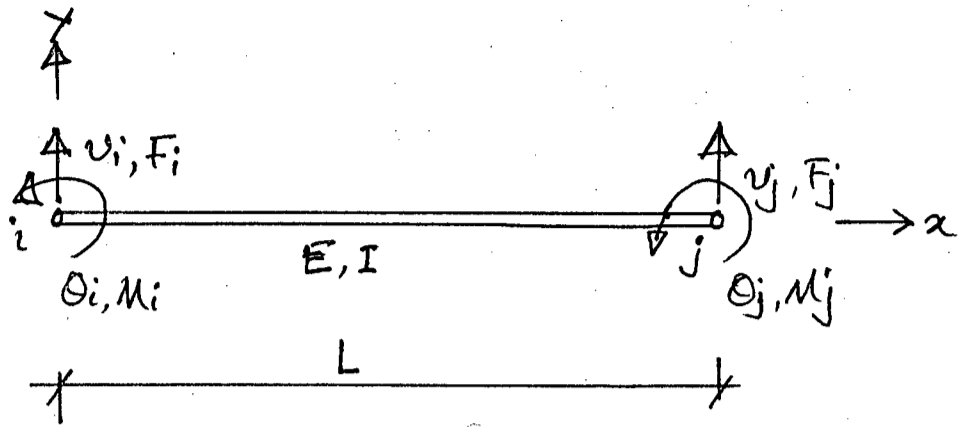

Figure 2

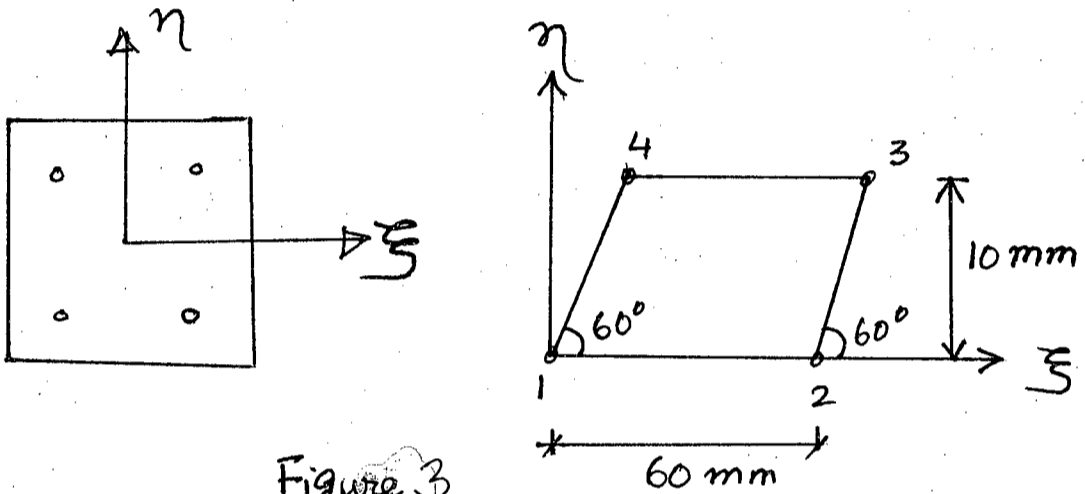

Figure 3

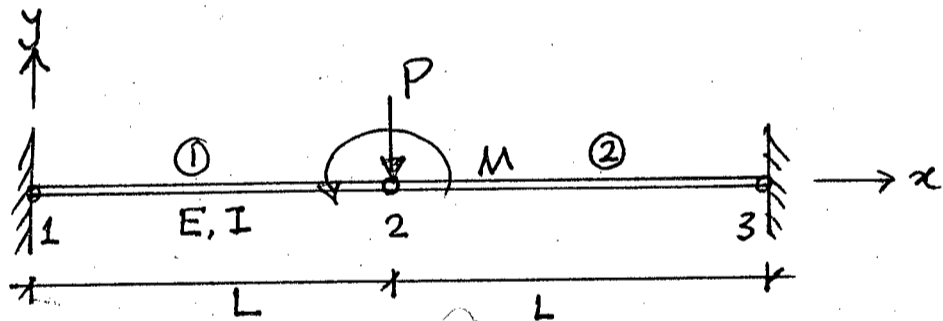

Figure 4

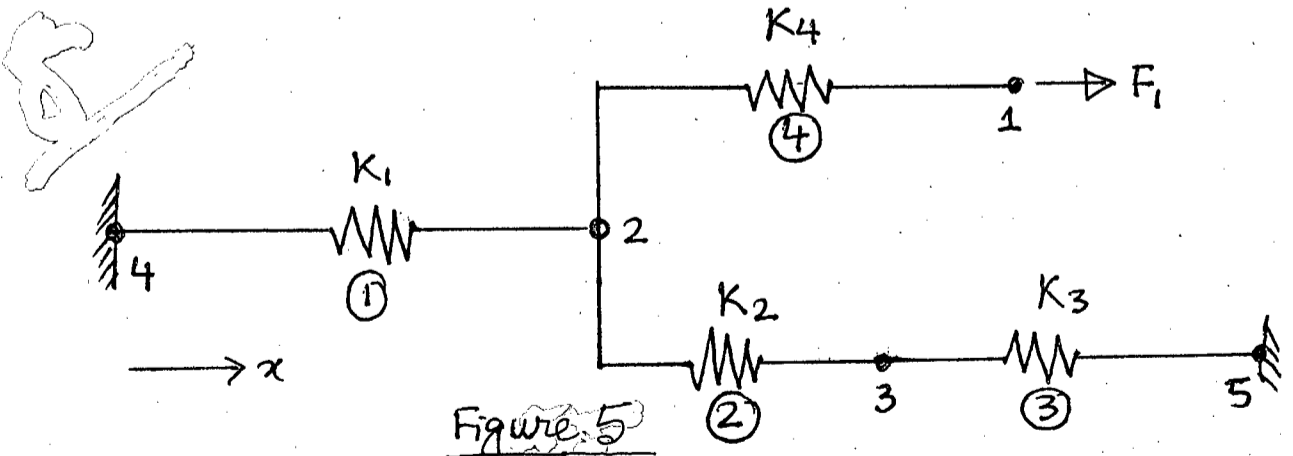

Figure 5

SECTION – A

There are **FOUR** questions in this section. Answer any **THREE**.

1. (a) In spite of individuals' differences in development priorities, there are some fundamental goals for which there is a general consensus. What are these fundamental goals of development? (6)
- (b) Distinguish between 'economic growth' and 'economic development'. Briefly discuss the concept of 'Human development'. What are the four major elements in the concept of human development? Discuss them briefly. (20)
- (c) Discuss briefly the weaknesses of GNI as a development indicator. (9)
2. (a) How does GDI differ from HDI? Draw a flow diagram of estimating GDI showing its dimensions, indicators, dimension indices and equally distributed indices. (15)
- (b) The following are some statistical data of a country (20)

| Indicators | Female | Male |
|---|--------|------|
| Life expectancy (years) | 73.2 | 64.9 |
| Probability at birth of not surviving to age 40 (%) | 15.5 | 16.2 |
| Adult literacy rate (%) | 69.3 | 74.6 |
| Gross educational enrolment ratio (%) | 94.1 | 97.3 |
| Estimated earned income (PPP \$) | 4875 | 7975 |

If the female population share of the country is 0.508, calculate the HDI representing average achievement of the country.

Also calculate the GDI reflecting the inequalities between men and women. Comment on the human development condition of the country based on these two values. Assume reasonable values for missing data, if any.

3. (a) Briefly discuss the concept of 'sustainable development'. (5)
- (b) List down the economic, social and environmental objectives of sustainable development. Briefly discuss their importance. (15)
- (c) "Sustainable development is about equity – intergenerational and intragenerational" – explain. (8)
- (d) What are the strategic imperatives for development to be sustainable? (7)

CE 403

4. (a) Make a list of large infrastructure development projects that required land acquisition. (5)
- (b) Development projects that displace people involuntarily give rise to severe economic, social and environmental problems – how? (10)
- (c) List down in a tabular form, the important differences between the Bangladesh Law (ARIP Ordinance, 1982), and World Bank and ABD's policies on land acquisition and resettlement, with respect to (20)
- (i) coverage, (ii) compensation, (iii) impact minimization, (iv) cut-off dates, (v) consultation, (vi) relocation assistance, and (vii) livelihood restoration.

SECTION – B

There are **FOUR** questions in this section. Answer any **THREE**.

5. (a) What is Community Participation? Define and explain in the context of Water Supply and Sanitation sector. (10)
- (b) Explain the various levels of Participation with examples of WSS sector. (25)
6. (a) What is a Client Centered Approach? Explain the concept with the responsibilities of implementing agencies of WSS related to development projects applicable for rural areas of Bangladesh. (20)
- (b) Why gender issue is important in WSS related projects in Bangladesh? How that can be taken care of while selecting new WSS facilities? (15)
7. (a) List the socio economic issues that must be considered in a project concerning water quality management planning. (18)
- (b) What are the Social Impact Assessment (SIA) variables to be addressed in an impact study? Explain the major and minor variables. (17)
8. (a) What are socio economic impacts of development projects? Explain the various types of impacts that one may experience after a development project is implemented. Why socio economic impacts of development projects are of great concern? Explain. (20)
- (b) What are the major difficulties in conducting socio economic assessments in development countries? (15)
-

BANGLADESH UNIVERSITY OF ENGINEERING AND TECHNOLOGY, DHAKA

L-4/T-2 B. Sc. Engineering Examinations 2012-2013

Sub : **CE 405** (Business and Career Development)

Full Marks : 210

Time : 3 Hours

The figures in the margin indicate full marks.

USE SEPARATE SCRIPTS FOR EACH SECTION

SECTION – A

There are **FOUR** questions in this section. Answer any **THREE**.

1. (a) What is an internship? What skills can one expect to gain from an internship and why is internship needed? What kinds of abilities and strategies do you need to identify to apply for internship? (18)
- (b) Describe requirement for internship success. (17)
2. (a) Describe the preparation steps before an interview. (18)
- (b) Discuss the typical stages during an interview. (17)
3. (a) Describe briefly the different stages of a career. (18)
- (b) Explain how external and internal career dimensions are linked with career stages. (17)
4. (a) Define operations management. State objectives of the operations subsystem and describe roles of the operation manager. Outline long run and short run decisions that operations manager have to make in an organization. (18)
- (b) Describe the basic environment in which decisions need to be made in an organization. Define inspection naming stages at which inspection can occur in a production process. Describe how extent and frequency of inspection is decided in a production system. Give examples of inputs and outputs in manufacturing and service industries. (17)

SECTION – B

There are **FOUR** questions in this section. Answer any **THREE**.

5. (a) Define Marketing Management. (5)
- (b) Briefly describe Negative Demand, Latent Demand, Irregular Demand and Overfull Demand. (20)
- (c) Show in a flow diagram the process of strategic planning, implementation and control. (10)

CE 405

6. (a) Briefly describe Boston Consulting Group's Model. (23)
- (b) Briefly describe Manufacturer Brands, Private Brands, Individual Brand and Family Brand. (12)
7. (a) Describe "Opportunity and Threat Analysis" and "Strength and Weakness Analysis" of business strategic planning. (18)
- (b) Describe the factors affecting man power planning. (5)
- (c) How do firms decide compensation (salaries or wages) for the work force? (5)
- (d) Briefly describe the series of activities involved in human resource planning. (7)
8. (a) What is 'Recruitment'? What are the factors affecting recruitment in an organization? Outline the features of recruitment policy. (2+4+5)
- (b) Briefly describe the sources of recruitment with examples. Mention the advantages and disadvantages of each sources of recruitment. (8+12)
- (c) Briefly describe the process of 'Downsizing' and 'Outsourcing' for a firm. (2+2)
-

BANGLADESH UNIVERSITY OF ENGINEERING AND TECHNOLOGY, DHAKA

L-4/T-2 B. Sc. Engineering Examinations 2012-2013

Sub : **CE 457** (Transportation Engineering V)

Full Marks : 140

Time : 3 Hours

The figures in the margin indicate full marks.

USE SEPARATE SCRIPTS FOR EACH SECTION

SECTION – AThere are **FOUR** questions in this section. Answer any **THREE**.

1. (a) Define Transportation Planning. Discuss the basic activities involved in a transportation planning process. (10 $\frac{1}{3}$)
- (b) Consider the following goal statement: "The transportation system should meet the mobility needs of the urban dwellers". Now, formulate two objectives statements that would help achieve this goal and also select two criteria that can be used to measure how well the objectives are met. (6)
- (c) What is meant by sustainable transport? What are the benefits of developing a sustainable urban transport system? (7)
2. (a) What different committees are created to help conducting a transportation planning study? (3)
- (b) What are the sequential travel demand forecasting models? Why are they called "sequential"? (5 $\frac{1}{3}$)
- (c) Explain the difference between "Origin-Destination" and "Production-Attraction". (4)
- (d) A three-zone city has the following trips produced and attracted at its zones: (11)

| Zone | 1 | 2 | 3 | Total |
|------------|-----|-----|-----|-------|
| Production | 700 | 200 | 0 | 900 |
| Attraction | 0 | 400 | 500 | 900 |

The calibrated friction factors and travel times are as follows:

| Travel Time (Min) | F_{ij} |
|-------------------|----------|
| 2 | 10 |
| 4 | 7 |
| 6 | 6 |
| 8 | 5 |

| | | Travel Time (min) | | | |
|------|---|-------------------|---|---|---|
| | | To | 1 | 2 | 3 |
| From | 1 | 2 | 4 | 6 | |
| | 2 | 4 | 2 | 8 | |
| | 3 | 6 | 8 | 2 | |

Distribute the trips among the zones. Assume, $K_{ij} = 1$.

CE 457

3. (a) Name the factors that affect the mode choice of travellers. How can the mode choice models be classified into different categories. (3+3)
- (b) What is the main difference between "all-or-nothing" and "capacity restraint" traffic assignment techniques? Which assignment technique would you use to assign trips into street network of Dhaka city? Why? (2+2+3 1/3)
- (c) Consider the following trip matrix and the street network. The link travel times are shown. Assign the trips and determine the link traffic volumes (total, both way). Use "all-or-nothing" technique. (10)

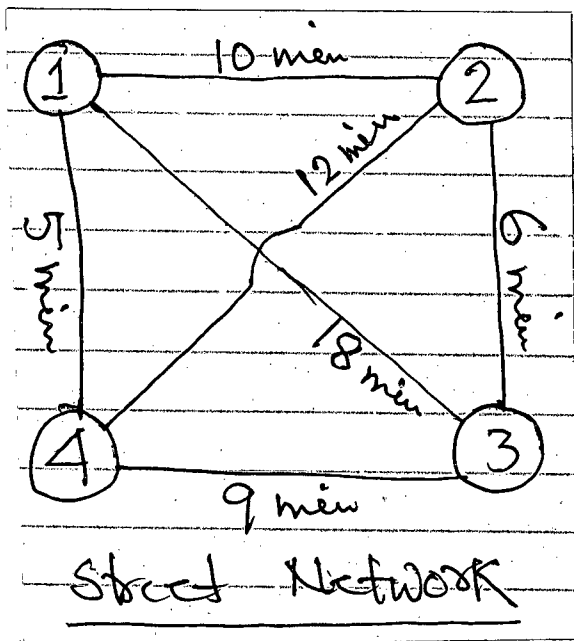

| Zone | 1 | 2 | 3 | 4 |
|------|-----|-----|-----|-----|
| 1 | --- | 300 | 500 | 200 |
| 2 | 200 | --- | 500 | 600 |
| 3 | 500 | 800 | --- | 400 |
| 4 | 400 | 500 | 600 | --- |

Trip Matrix

4. (a) Given the utility equation (4+4)

$$U_k = a_k - 0.003X_1 - 0.04X_2$$

where X_1 is travel cost in cents and X_2 is travel time in minutes.

- (i) Calculate the market shares of following modes

| Mode K | a_k | X_1 | X_2 |
|-------------|-------|-------|-------|
| Automobile | -0.20 | 120 | 30 |
| Express Bus | -0.40 | 60 | 45 |
| Regular Bus | -0.60 | 30 | 55 |

- (ii) Estimate the effects that a 50% increase in automobile cost and 20% decrease in regular bus cost will have on modal split.

- (b) Name six transport system management actions that can be adopted to ensure efficient use of road space. (3 1/3)

- (c) Write short notes on the following transport demand management measures: (12)

- (i) Road Pricing
- (ii) Parking Management

CE 457

SECTION – B

There are **FOUR** questions in this section. Answer any **THREE**.

5. (a) State the purposes and implications of road classification systems. Explain the hierarchical classification of the urban road system with respect to movement functions, attributes and activities. (11)

(b) List the most notable urban transport problems. In automobile dependent cities, what measures can help alleviate congestion to some extent? (12 1/3)

6. (a) What are the most difficult challenges that urban transit faced in the developed countries? (11)

(b) A bus system needs to be set up between the BUET Campus and the Uttara University Campus, distance of 8.5 miles. The operating time is 30 minutes. It has been estimated that the peak hour demand is 400 passenger/hour and 45-seater buses are available, which can safely accommodate 20 standees. Design the basic system and determine the fleet size assuming that the minimum terminal time is 7.5 minutes, which may be revised if necessary. (12 1/3)

7. (a) Draw the possible road patterns based on different layouts of towns, industrial and production centers and the choice of the planning engineer. (11)

(b) There are four alternate plan proposals P, Q, R and S for four different road lengths, population and products served as given below. (12 1/3)

| Proposal | Total road length (km) | Number of towns and villages served with population ranges | | | | Total agricultural and industrial products (1000 tones) |
|----------|------------------------|--|-----------|------------|--------|---|
| | | 1001-2000 | 2001-5000 | 5001-10000 | >10000 | |
| P | 300 | 160 | 80 | 30 | 6 | 200 |
| Q | 420 | 200 | 90 | 60 | 8 | 270 |
| R | 500 | 240 | 112 | 70 | 10 | 310 |
| S | 600 | 248 | 120 | 73 | 12 | 335 |

Work out the utility per unit length for each of the systems and indicate which of the plans yields the maximum utility based on saturation system. Assume missing data, if any.

8. (a) Briefly discuss the commonly encountered issues involving truck loading/unloading in a CBD area. (5 1/3)

(b) Given the benefits and costs schedule shown below for transportation projects A, B and C, determine which project is best from an economic efficiency point of view. Conduct the assessment for discount rates of 8 percent, 10 percent, and 12 percent. How does the discount rate affect the choice of the "best" project? (18)

CE 457

Contd ... Q. No. 8(b)

| Year | Expected yearly cost (\$) | | | Expected yearly benefit (\$) | | |
|------|---------------------------|----|----|------------------------------|----|----|
| | A | B | C | A | B | C |
| 1 | 10 | 30 | 10 | 0 | 0 | 0 |
| 2 | 15 | 10 | 10 | 5 | 20 | 15 |
| 3 | 30 | 10 | 10 | 10 | 20 | 15 |
| 4 | 15 | 5 | 10 | 15 | 10 | 10 |
| 5 | 10 | 5 | 10 | 15 | 10 | 5 |
| 6 | 5 | 5 | 5 | 10 | 10 | 5 |
| 7 | 5 | 5 | 5 | 10 | 10 | 5 |
| 8 | 5 | 5 | 5 | 10 | 5 | 5 |
| 9 | 5 | 5 | 5 | 5 | 5 | 5 |
| 10 | 5 | 5 | 5 | 5 | 5 | 5 |

SECTION – AThere are **FOUR** questions in this section. Answer any **THREE**.

1. (a) Define magnitude and intensity of an earthquake. For 2015 Nepal earthquake what was this values in Kathmandu and Dhaka? Explain. (4+6=10)
- (b) Explain different types of waves with neat sketches. (9)
- (c) Estimate probability of earthquake hazard for residential building for a return period of 50, 100, 475 years. (4 1/3)
2. (a) Differentiate between Seismic Microzonation and Siesmic Zonation with neat sketches. (6)
- (b) Two hypothetical soil deposits overlying rigid bedrock: (A) Site A and (B) Site B are shown below. Explain Amplification for the two sites. (9)

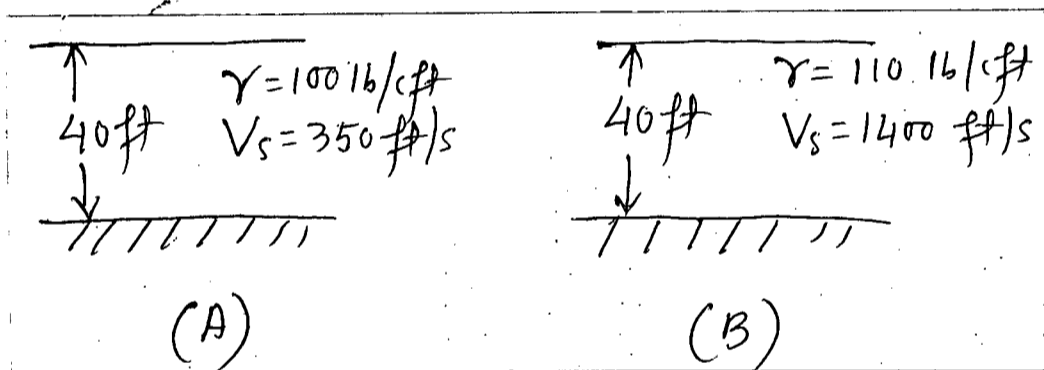

- (c) What phenomena was observed in Maxico city during the 1985 Maxico earthquake? (8 1/3)
3. (a) Explain simplified procedures for estimating soil liquefaction on sandy soil. (8 1/3)
- (b) Explain four types of countermeasures against liquefaction for building foundation. (6)
- (c) Estimate liquefaction potential at 3m depth of a proposed construction site for a 7.5 magnitude earthquake. Producing a peak ground acceleration of 0.22g. Consider the water table at 0.75 m below the GL. The soil is coarse sand with a saturated unit wt. of 19 kN/m^3 . The field SPT-N value, and d_{50} with depth is provided below. (9)

| | | | |
|---------------|------|------|-----|
| Depth (m) | 1.5 | 3.0 | 4.5 |
| N-Value | 2 | 3 | 4 |
| d_{50} (mm) | 0.81 | 0.95 | 1.1 |

4. (a) Write short notes on: (6×2=12)
- (i) Dynamic Compaction
- (ii) Blasting

CE 445

Contd ... Q. No. 4

(b) There are three seismoactive zones in and around a particular site. Estimate SDE and SSE earthquake on the basis of cumulative intensity-frequency relation.

(11 1/3)

| Zone | a | b | I _{max} | ΔI |
|------|------|------|------------------|-----|
| 1 | 0.45 | 0.39 | XI | 2.1 |
| 2 | 0.85 | 0.60 | IX | 1.6 |
| 3 | 0.75 | 0.55 | X | 2.0 |

SECTION – B

There are **FOUR** questions in this section. Answer any **THREE**.

Assume reasonable value of missing data.

5. A machine foundation weighs 75 kN and has a spring constant $k = 12,000$ kN/m. The weight of the machine is 15 kN. Assuming the damping coefficient c of the system as equal to 160 kN-sec/m, determine:

(12)

- (a) Natural frequency of the system,
- (b) Whether the system is over-damped, under-damped or critically damped,
- (c) The ratio of two successive amplitudes,
- (d) The damped natural frequency, and
- (e) Viscous force vector and inertia force vector,
- (f) If $c = 800$ kN-sec/m, show the qualitative diagram of motion of the system.

(b) Derive for a damped-free vibration:

(11 1/3)

$$z = Z_0 \frac{e^{(-\omega_{nd} Dt)}}{\sqrt{1 - D^2}} \sin(\omega_{nd}t + \phi)$$

where, the symbols have their usual meanings.

6. For the system represented by the following equation:

$$m \frac{d^2z}{dt^2} + c \frac{dz}{dt} + kz = Q_0 \sin \omega t$$

Deduce the magnification factor:

$$M = \frac{1}{\sqrt{\left(1 - \frac{\omega}{\omega_n}\right)^2 + \left(2D \frac{\omega}{\omega_n}\right)^2}}$$

Using the above expression, show that resonance occurs at a frequency ratio slightly less than one and the corresponding magnification M_{max} is given by:

$$M_{max} = \frac{1}{2D \sqrt{1 - D^2}}$$

Also, explain what will happen if the supporting foundation system processes an equivalent damping ratio of $1/\sqrt{2}$.

(8+7+4+4 1/3)

CE 445

7. (a) Derive the following expression for natural frequency of a block of machine and its foundation system subjected to rocking vibration:

$$\omega_{\phi x} = \sqrt{\frac{C_{\phi} I - WL}{M_{m0}}}$$

Where M_{m0} is the mass moment of inertia of the machine and foundation about the axis of rotation. Also show the maximum displacement A_{ϕ} is given:

$$A_{\phi} = \frac{M_0}{M_{m0} (\omega_{n\phi}^2 - \omega^2)}$$

State briefly why is rocking vibration on a block always coupled with sliding mode of vibration.

(10+2+3 1/3)

- (b) A body weighing 65 kg is suspended from a spring which deflects 1.57 cm under the load. It is subjected to a damping effect adjusted to a value 0.25 times that required for critical damping. Find the natural frequency of the un-damped and damped vibrations, and in the latter case, determine the ratio of successive amplitudes. If the body is subjected to a periodic disturbing force with a maximum value of 25 kg and a frequency to 0.75 times the natural frequency, find the amplitude of forced vibration and the phase difference with respect to the disturbing force.

(8)

8. (a) State general requirements of machine foundations. Also state the general requirements of data for the purpose of machine foundations design.

(6+4 1/3)

(b) State and describe the principles of various methods for vibration isolation. Describe briefly the ways of vibration minimization mentioning at least two examples for each method.

(8)

(c) Show graphically the effects of the magnitude of damping ratio on vibration amplitude in an SDOF system for the following cases:

(5)

- (i) free vibration
- (ii) force vibration

SECTION – A

There are **FOUR** questions in this section. Answer any **THREE**.

Assume reasonable value of missing data, if any.

Use attached charts where necessary.

1. (a) Derive Kozeny-Carman equation for coefficient of permeability of soil. (8)
 (b) Mention the main reasons of non-Darcy behaviour in soils as reported by various researchers. Also define permeability parameters n and C . (7)
 (c) Mention the assumptions for determining permeability of soils in field by pumping test. With neat figures describe the constant head borehole permeability test to estimate coefficient of permeability in the field. What are the possible sources of errors in this test? (8 $\frac{1}{3}$)

2. (a) Derive Laplace's equation in two dimensions. Also show that both the potential function and stream function satisfy Laplace's equation. (8)
 (b) Mention the basic requirements to be fulfilled for the construction of flow net. What are the possible boundary conditions for drawing flow net in an earth dam? (6 $\frac{1}{3}$)
 (c) Draw neatly the entrance and exit requirements of the line of seepage. (4)
 (d) A homogeneous earth embankment of height 14 m was built on an impervious foundation with side slopes 3 : 1 (horizontal : vertical). The embankment retains water to a height of 12 m. The crest width of the embankment is 3 m. The coefficient of permeability of the embankment soil is 4×10^{-5} m/sec. Calculate the rate of seepage through the embankment using Schaffernak and Van Iterson's method. (5)

3. (a) A homogeneous earth embankment of height 12 m was built on an impervious foundation with side slope 0.5 : 1 (horizontal : vertical). The embankment retains water to a height of 10 m. The crest width of the embankment is 3 m. Plot the line of seepage using A. Casagrande's method. (Use plain graph paper for plotting). (10)
 (b) With neat sketches, describe the procedure of determining coefficient of permeability in the laboratory by horizontal capillarity test. (6)
 (c) Derive an expression for the factor of safety (F.S.) of an infinite slope in a cohesive soil ($c-\phi$) with seepage parallel to the slope and is occurring throughout the slope (i.e., water table is at surface). Also deduce an expression for critical height of the slope. (7 $\frac{1}{3}$)

CE 447

4. (a) Saturated unit weight and effective angle of internal friction (ϕ') of a cohesionless soil are 18 kN/m^3 and 30° , respectively. A slope is to be made of this material. If the factor of safety is to be 1.5, determine the safe angle of the slope for the following cases: **(5)**
- (i) When the slope is dry.
 - (ii) When seepage occurs at and parallel to the slope (i.e., water table is at the surface).
- (b) Derive an expression for determining the rate of seepage through an earth dam resting on an impervious base using Leo Casagrande's method. Also state the procedure of plotting the line of seepage using this method. **(8 1/3)**
- (c) An earth dam of height 6 m was cut at a slope angle of 60° through a silty clay soil. The values of cohesion, angle of internal friction and saturated unit weight of the soil are 25 kN/m^2 , 10° and 20 kN/m^3 , respectively. Using Taylor's method, determine the factor of safety when the reservoir is full to the top level of the cut. What will be the factor of safety in case of a sudden drawdown? **(6)**
- (d) A 10 m thick aquifer is confined at top and bottom by an impervious stratum. The top impervious stratum is 8 m thick. A test well was sunk up to the lower impervious stratum. The maximum drawdown produced by steady pumping from well is 3 m. The diameter of the well is 0.3 m and the maximum radius of influence of the well may be assumed as 200 m. If the coefficient of permeability of the aquifer is $5 \times 10^{-4} \text{ m/sec}$, calculate the rate of flow of the well. **(4)**

SECTION – B

There are **FOUR** questions in this section. Answer any **THREE**.

5. (a) Give two examples related to soil-water interaction problems – one related to buoyancy of underground water reservoir and the other related to change of cohesionless soil's shear strength due to rise of water level. **(8 1/3)**
- (b) Describe the mechanisms related to: **(15)**
- (i) Topsoil erosion of a hill slope
 - (ii) Block slide of a hill slope
 - (iii) Failure of river bank slope
6. (a) Mention the salient geometric and hydraulic properties of open mesh type jute geotextiles. Explain how this can be used for topsoil erosion control of hill slopes with necessary sketches. **(10)**
- (b) What properties of a geotextile shall have to be determined in the laboratory for use in river bank protection work as filter? Describe in brief, how these properties may be obtained. **(13 1/3)**

CE 447

7. (a) What river bank protection scheme is commonly employed in Bangladesh? Describe the function(s) of each of the components of such scheme. (13 1/3)

(b) Evaluate the filtration capacity of a candidate geotextile for placement beneath a rock riprap erosion control system on a river bank slope with 1.5 m tidal difference in every 6 hours as shown in the following sketch. The candidate geotextile's laboratory properties are: permittivity = 0.7 s^{-1} and AOS = 0.30 mm. The properties of in-situ soil of river bank are: $C_u = 3.5$, $d_{50} = 0.15 \text{ mm}$, $d_{90} = 0.35 \text{ mm}$ and porosity = 0.45. The reduction factors for geotextile are: $RF_{scb} = 10$, $RF_{cr} = 1.2$, $RF_{in} = 1.3$, $RF_{cc} = 2.5$, $RF_{bc} = 3.0$. Assume a reasonable phreatic surface for the purpose of calculation of discharge. Assume reasonable value for missing data, if any. (10)

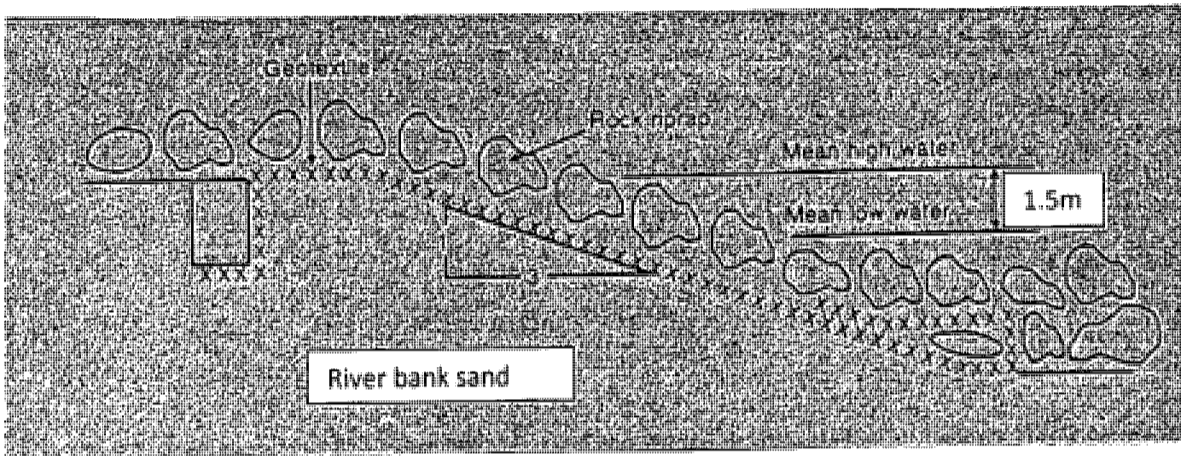

8. (a) What are the basic issues that must be considered during design of a revetment structure? Explain. (8 1/3)

(b) For the design of a revetment structure, following data are available for a river in Bangladesh: (15)

- Discharge: 18 cumec
- High water level: 7.0 m
- Average low water level: 2.0 m
- Average flow velocity: 3.5 m/sec
- Revetment material: Boulder
- Specific gravity of the boulder: 2.65
- Ratio of water depth and revetment size: 5.0
- Slope of bank: 30 degree
- Angle of repose of boulder: 45 degree

Determine the size of the boulders so that they are stable against current action using (i) Neill's method and (ii) *JMBA method. Also determine the thickness of the riprap to conclude the design. Assume reasonable value of missing data, if any.

* JMBA equation is supplied for convenience:

$$D_n = \frac{0.7 V^2}{2 (S_g - 1) g} \frac{2}{\log \left[\frac{6h}{D} \right]^2} \frac{1}{\left[1 - (\sin \theta / \sin \Phi)^2 \right]^{0.5}}$$

=4=

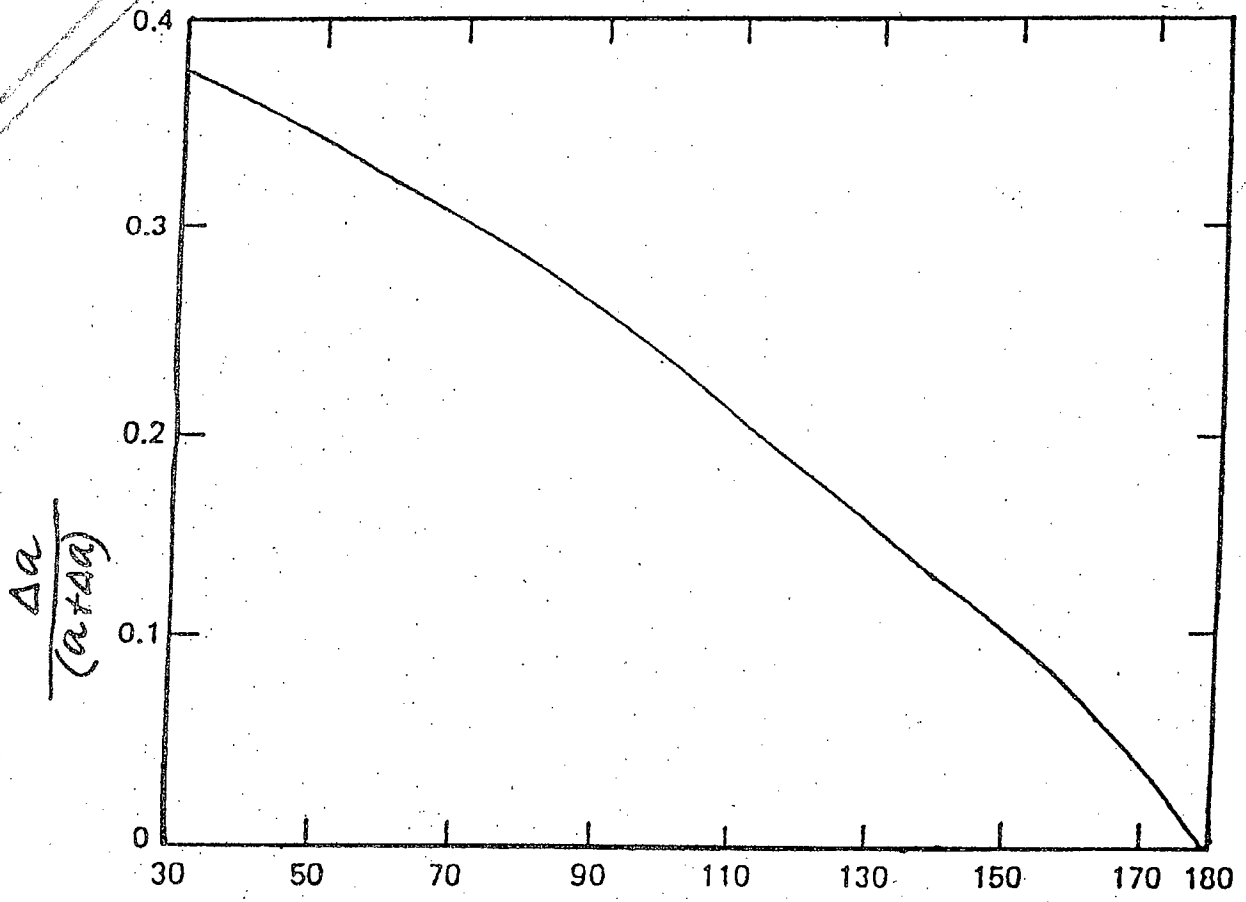

Downstream slope angle, β

Chart - 1

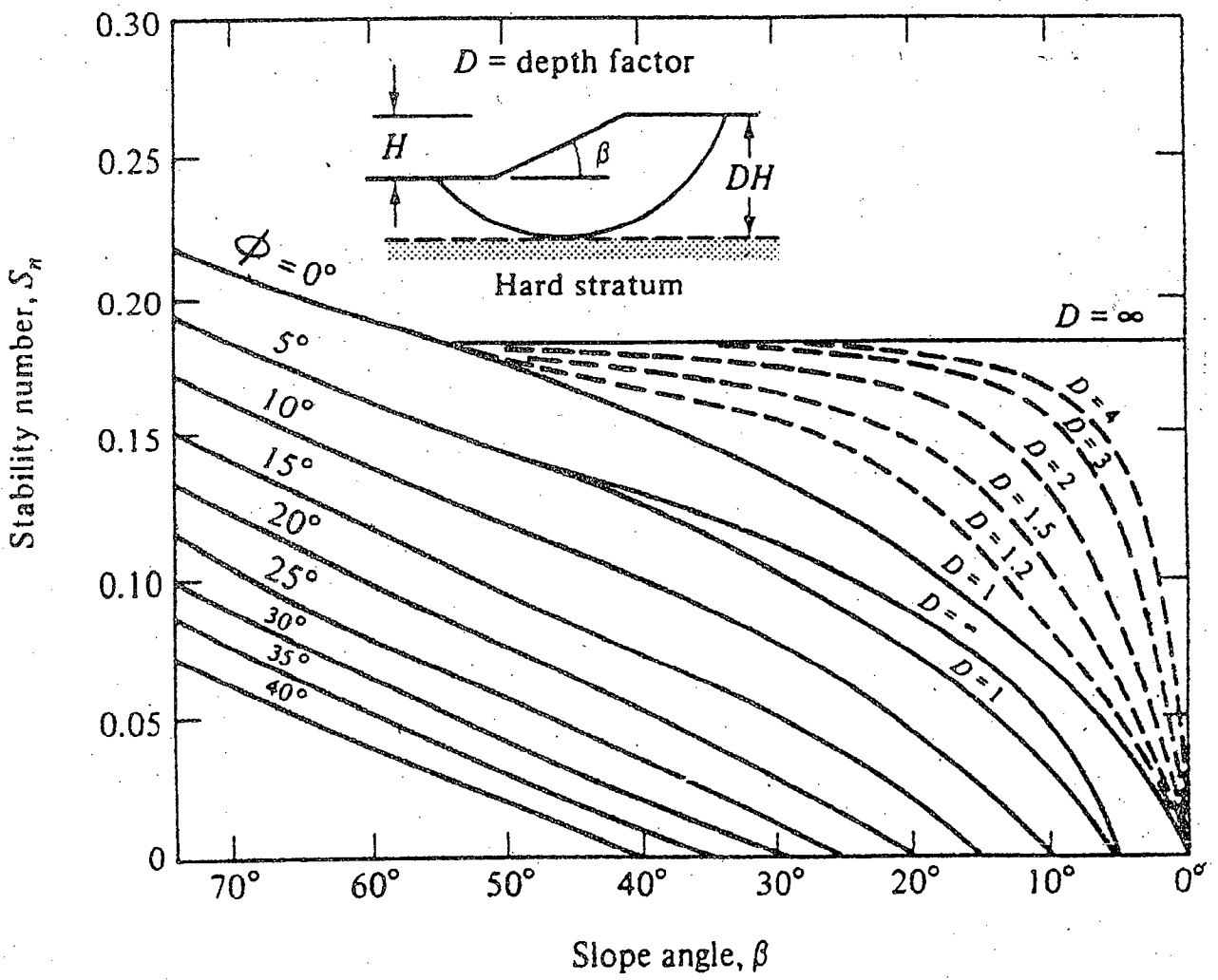

Chart - 2

Sub : **CE 453** (Transportation Engineering III : Traffic Engineering
Design and Management)

Full Marks : 140

Time : 3 Hours

The figures in the margin indicate full marks.

USE SEPARATE SCRIPTS FOR EACH SECTION

SECTION – AThere are **FOUR** questions in this section. Answer any **THREE**.

Assume reasonable values for missing data.

1. (a) Explain the meaning, principles, objectives and actions of Traffic Management with particular focus on the need for urban areas of Bangladesh. Outline the procedures for the development of a Traffic Management Scheme. Cite some good examples of traffic management schemes in developing countries. (12 $\frac{1}{3}$)
- (b) Clearly define Traffic Control Devices and state their purposes and fundamental requirements. Explain the meaning and types of uniformity in traffic control devices. List some typical locations that warrant warning sign indicating their placement in accordance with the MUTCD recommendations. Enumerate different types of pavement markings depicting their dimensions and patterns. (11)
2. (a) Define congestion and explain congestion phenomena, factors and characteristics in the context of urban transport in developing countries like Bangladesh. Define and explain the functions, hierarchy and classifications of the urban road system with particular implications to Traffic Management Actions. (8 $\frac{1}{3}$)
- (b) Define Super Street Arterials and list different design options for taking their full advantages including principles of intersection improvements. State the warrants and benefits of one-way streets. (8)
- (c) Explain strategic approaches, key issues and solution options for tackling traffic congestion in metro Dhaka. In which way the capacity of the urban road system could be increased by upto five times. (7)
3. (a) Define road traffic accident according to the UK Department of Transport and state some basic accident data items to be collected for developing effective remedial measures. Explain Haddon Matrix and Collision Diagram and their usefulnesses in mitigating road safety problem. (9)
- (b) Define and briefly explain the process of investigations of Hazardous Road Locations (HRL) Program and diagnosis of accident problems and counter measures development. (8)
- (c) Explain Road Safety Audit, Inspections and Assessment. State the essential requirements, stages and checklists of road safety audit. (6 $\frac{1}{3}$)

CE 453

4. (a) Discuss the significance of Non-motorised Transport (NMT) in urban areas of Bangladesh with special focus on pedestrians and bicyclists. List some common traffic engineering measures for protecting the legitimacy and safety of pedestrians and bicyclists. Also list some specific remedial treatments for right angle and rear-end collisions at intersections. (10)

(b) Explain road safety strategies and the main principles for safer road environment.

Write notes on:

(13 1/3)

- (i) Transport Demand Management
- (ii) Local Area Traffic Management (LATM)
- (iii) Arterial Access Management.

SECTION – B

There are **FOUR** questions in this section: Answer any **THREE**.

5. (a) Explain five measurement procedure for collecting following traffic related data. (13 1/3)

(i) Traffic volume (ii) Speeds (iii) Travel time (iv) Density and (v) Time headway

(b) Deduce a relationship between occupancy and density of road traffic. (5+5=10)

For the following data on speed and density, determine the parameters of the Greenshield's model.

| | | | | | | | | | | | | |
|------------|----|----|----|----|----|----|----|----|----|-----|-----|-----|
| u (kmph) | 75 | 75 | 65 | 55 | 40 | 50 | 30 | 35 | 20 | 30 | 10 | 10 |
| k (veh/km) | 10 | 20 | 30 | 40 | 50 | 60 | 70 | 80 | 90 | 100 | 100 | 110 |

6. (a) Draw a generalized shape of speed-flow curve showing three possible flow regimes and explain the flow regimes. Also, explain the capability of classical volume-delay function in a Flow-Travel time plot. Explain the equations and parameters of Davidson and US BPR volume-delay functions. (13 1/3)

(b) It is claimed that driver behavioral and interaction aspects, not well covered in traditional volume-delay function, are given due attention in micro-simulation modeling approach. Explain general car following model equation for micro-simulation. Also, discuss the components of road traffic micro simulation model. (10)

7. (a) Explain signal synchronisation in a labelled diagram with subsequent explanation of labels such as cycle time, Bandwidth, Offset, Reference point, green and red phase, etc. (13 1/3)

Using Webster optimal cycle length formulae $\left(C_0 = \frac{1.5L + 5}{1 - \gamma} \right)$, plot a curve of C_0 vs. γ

for a total lost time of 10s and γ values upto 1. Comment on the drawn graph about traffic signal performance over range of demand.

CE 453

Contd ... Q. No. 7

(b) An offside priority roundabout type of junction control is considered for two 2-lane 2-way highway intersection. From geometric design analysis, entry capacity of the roundabout approaches is given as, $Q_e = F - f_c Q_c$, where $F = 1200$ pcu/hr and $f_c = 0.56$.

During operation, the same entry capacity can be estimated using the formulae, **(10)**

$$Q_e = \frac{Q_c \cdot e^{-Q_c t_c / 3600}}{1 - e^{-Q_c t_f / 3600}}$$

where, average t_c and t_f are given as 4.3s and 2.9s. Plot Q_c vs. Q_e on graph paper for both consideration and comment on the results.

8. (a) What are the communication mechanisms with driver for traffic marking, signs and signals? Discuss different traffic marking in details. What potential information do the warning signs carry to drivers? Write down names and purposes of various traffic signals. **(1 1/3 + 6 + 3 + 3 = 13 1/3)**

- (b) Write down the names of technology oriented and application oriented ITS applications. Explain with diagram, the features of a Single Point Urban Interchange (SPUI); why it is preferable to other grade separation treatment in urban areas. **(3+4+3=10)**
-

SECTION – A

There are **FOUR** questions in this section. Answer any **THREE**.

1. (a) Briefly state the ways in which lack of drainage affects the performance of highways. **(10)**
 (b) Briefly state the prevention of erosion in drainage channels. **(9)**
 (c) Determine the depth and velocity of flow in a trapezoidal channel ($n = 0.030$) with 2 to 1 side slopes and 4-ft bottom width discharging $60 \text{ ft}^3/\text{sec}$ on a slope of 2 percent. Assume reasonable values for missing data, if any. **(4 1/3)**

2. (a) Why is subsurface drainage needed? Show how are the subdrains placed for subgrade drainage and for lowering ground water table. **(12)**
 (b) Show the drainage system in an urban intersection. Briefly state the basic elements of urban drainage system. **(11 1/3)**

3. (a) Showing the definition of terms related to aircraft dimensions, briefly state relevant aircraft characteristics for airport pavement design. **(12 1/3)**
 (b) What are the ways by which stress are induced in rigid airport pavements? What is the application of fatigue concept to traffic analysis as per PCA? **(11)**

4. (a) Briefly state the various steps for the evaluation and design of overlays using layered elastic theory. **(10)**
 (b) Define ACN and PCN. Show the flow chart indicating the procedure for determining the ACN for flexible pavement. **(10)**
 (c) What are the functions of an airport drainage? **(3 1/3)**

SECTION – B

There are **FOUR** questions in this section. Answer any **THREE**.

5. (a) Write a brief essay on the growth of aircraft's size, speed, and productivity in the last sixty years. **(12 1/3)**
 (b) Name the different levels of airport planning. What guidelines are usually provided in an airport master plan? **(11)**

CE 455

6. (a) Make a list of the factors that facilitate the process of establishing site selection criteria for a new airport. (7)
- (b) Describe the runway lighting system and approach lighting system. (13 1/3)
- (c) How does FAA classify runways for marking purposes? (3)
7. (a) Explain how the runways are numbered. (5)
- (b) Name the different types of airport configurations. Explain, in detail, the parallel runway and open-V runway configurations. (13 1/3)
- (c) Mention the colors of the followings: (5)
- (i) Runway threshold light, (ii) Runways edge light, (iii) Runway centerline light, (iv) Taxiway edge light, and (v) Taxiway centerline light.
8. (a) Describe the activities and corresponding physical facilities that are provided in the major components of an airport passenger terminal system. (9 1/3)
- (b) Explain how the airport terminal facility is classified functionally. (6)
- (c) Describe the horizontal distribution concepts for airport passenger terminals. (8)
-