

Page 2/6/2014

L-4/T-2/IPE

Date : 07/06/2014

BANGLADESH UNIVERSITY OF ENGINEERING AND TECHNOLOGY, DHAKA

L-4/T-2 B. Sc. Engineering Examinations 2011-2012

Sub : **IPE 427** (Marketing Management)

Full Marks : 210

Time : 3 Hours

The figures in the margin indicate full marks.

USE SEPARATE SCRIPTS FOR EACH SECTION

SECTION – A

There are **FOUR** questions in this section. Answer any **THREE**.

1. (a) Differentiate a business market and a consumer market. (8)
(b) A business organization produces sports car. Describe different stages in the buying process for the raw material and different component parts of the car for the organization. (20)
(c) Who are the participants in the business buying process and what are their roles? (7)
2. (a) Describe behavioral segmentation of a market. (13)
(b) Explain the five forces that determine the intrinsic long-run attractiveness of a market or a market segment. (12)
(c) Explain the four approaches of possible levels of market segmentation. (10)
3. (a) A company produces different types of soft drink. Explain how it can expand the total market demand. (8)
(b) A company is a market challenger in the sports car market. Describe its competitive strategies to challenge the market leader. (15)
(c) For a digital camera, explain how marketing strategies change with the product's life cycle. (12)
4. (a) Explain how consumer goods can be classified. (8)
(b) A company produces bicycle. Describe how the company can differentiate its product from the competitor's products. (15)
(c) Describe how a company that produces men's fashion wear can lengthens its product line. (12)

SECTION – B

There are **FOUR** questions in this section. Answer any **THREE**.

5. (a) Mention different types of product that are marketed with examples. (8)
(b) Explain different types of competition. Describe the marketing concept of company orientation toward the marketplace. (7+7=14)
(c) Describe how a company responds and adjusts in a changing marketing environment. (13)

Contd P/2

IPE 427

6. (a) Define market-oriented strategic planning. Describe the process of assigning resources to strategic business units (SBUs). **(3+15=18)**
- (b) Explain different types of growth strategy. **(9)**
- (c) Describe how marketing intelligence can be collected on the internet. **(8)**
7. (a) Describe the demographic environment as a major force influencing marketing environment. **(14)**
- (b) Describe the development of a research plan in the market research process. **(16)**
- (c) Explain the role played by a family in consumer buying decisions. **(5)**
8. (a) Describe cultural factors that influence consumer buying behavior. **(7)**
- (b) A consumer wants to buy a new smartphone. Describe how the consumer will perform the "problem recognition", "information search" and "evaluation of alternatives" stages in the buying decision process. **(16)**
- (c) Explain the purchase decision process and different post-purchase behavior of a consumer after a purchase decision. **(12)**
-

Signature
11.05.2014

L-4/T-2/IPE

Date : 10/05/2014

BANGLADESH UNIVERSITY OF ENGINEERING AND TECHNOLOGY, DHAKA

L-4/T-2 B. Sc. Engineering Examinations 2011-2012

Sub : **IPE 411** (Industrial and Business Management)

Full Marks : 210

Time : 3 Hours

The figures in the margin indicate full marks.

USE SEPARATE SCRIPTS FOR EACH SECTION

SECTION – A

There are **FOUR** questions in this section. Answer any **THREE**.

1. (a) Name four major approaches to management. (5)
(b) Discuss any five of Fayol's 14 principles of management with appropriate example. (18)
(c) Elaborate four variables in contingency approach of management. (12)
2. (a) What are the characteristics of strong cultures and weak cultures of an organization? (8)
(b) How can you create an innovative culture in a mechanistic organization? (12)
(c) Briefly explain seven steps of decision making process in purchasing a vehicle. (15)
3. (a) How can you distinguish Related diversification from Unrelated diversification in growth strategy? Provide example. (8)
(b) Briefly discuss BCG Matrix. (12)
(c) Elaborate five competitive forces in industry analysis. (15)
4. (a) How can you define a Boundaryless organization? (5)
(b) What are the factors that affect the width of span to control organizational staff? (12)
(c) Mention the benefits and limitations of Product, Process and Functional departments. (12)
(d) Name three different skills of a manager to perform his job successfully. How can you relate these skills of different management levels with the level of importance? (6)

SECTION – B

There are **FOUR** questions in this section. Answer any **THREE**.

5. (a) Describe the complete Human Resource Management (HRM) Process. Use flowchart to describe relationships among different functions of HRM. (20)
(b) What are the possible "Selection Decision Outcomes" in HRM? (15)

Contd P/2

IPE 411

6. (a) Explain "Managerial Grid" theory of Leadership. (20)
(b) What were the findings of "Fiedler Model" of Leadership? (15)
7. (a) Explain Theory X and Y, to describe human behavior for motivation. (20)
(b) What are the different types of "justice", as per Equity theory of motivation? Explain. (15)
8. (a) Describe a "Team Effectiveness Model" of Work Team. (20)
(b) Explain different stages of Group Development. (15)
-

SECTION – A

There are **FOUR** questions in this section. Answer any **THREE**.

1. (a) A furniture manufacturing company Furncom buys steel locks from Lockhard company. The steel locks are used in furniture. Furncom has a policy to maintain 96% CSL value. Safety stock of steel lock is 2400 pieces, which is equivalent to 4 days' stock, as per mean daily demand. Standard deviation of daily demand of steel lock is 100 pieces. Lockhard company takes an average lead time of 3 days. **(20)**
- (i) What is the standard deviation of demand during lead time?
- (ii) What is the standard deviation of lead time?
- (b) Define Consistency Ratio (C.R.) with respect to AHP method of supplier selection. **(15)**
2. (a) Essex company buys materials from 3 closely related suppliers. Annual demands of all of those 3 materials are 10,000 pieces each. Holding cost for all is 20% of value of material. Purchase price is \$ 50/piece for each of the three types of materials. Common ordering cost is \$ 500/order. Supplier specific ordering costs are also equal, which is 125 \$/order.
- Weights of all 3 materials are 10 kg/piece. A truck has a maximum allowable carrying capacity of 21,900 kg at a time.
- Calculate, under capacity constraint of truck –
- (i) Procurement lot size per supplier per order **(10)**
- (ii) Annual ordering and holding cost per supplier **(10)**
- (b) Toyota uses two different formats of "Direct Shipping with Milk Runs" in Japan and the USA. Explain. **(15)**
3. (a) A retailer buys a product from its manufacturer, under marginal unit quantity discount, as follows:

Price break levels	Order quantity (pieces)	Marginal unit Price (\$)
i = 0	0 – 3000	5.00 \$
i = 1	3000 – 8000	4.80 \$
i = 2	8000 – more	4.50 \$

IPE 451

Contd ... Q. No. 3(a)

Holding cost is 25% of the value of product. Ordering cost is \$ 200/order; Annual demand is 52,000 pieces.

For "Price break level" $i = 1$, compute the followings –

- (i) Optimum lot size (8)
- (ii) Total annual inventory cost. (12)
- (b) Describe "Manufacturing cross-docking" and "Distribution Center cross-docking". (15)
- 4. (a) Distinguish between supply chains of 7-Eleven and Wal-Mart supermarket chains. (15)
- (b) Explain "Off-shoring" and "3PL Logistics Provider". (15)
- (c) Give an example of cross-docking in distribution in Dhaka city. Explain its operation in brief. (5)

SECTION – B

There are **FOUR** questions in this section. Answer any **THREE**.

- 5. (a) Explain the objectives of a supply chain. (8)
 - (b) Describe the supply chain of Dell Computer. (10)
 - (c) Describe cycle view of supply chain processes. (17)
 - 6. (a) Describe the three basic steps to achieve strategic fit. (23)
 - (b) Describe the value chain in a company. Mention the differences between value chain and supply chain. (8+4=12)
 - 7. (a) Describe the role of distribution in a supply chain with examples. (10)
 - (b) Describe the following types of distribution network: (18)
 - (i) Manufacturing storage with direct shipping and in-transit merge.
 - (ii) Distribution storage with package carrier delivery.
 - (c) Explain the impact of e-business on Grocery industry. (7)
 - 8. (a) Describe the factors influencing distribution network design. (15)
 - (b) Describe the role of "in house" and "outsourcing" of logistics operations in W. W. Grainger. (5)
 - (c) Describe the factors that must be considered in supplier scoring and assessment. (15)
-

SECTION – A

There are **FOUR** questions in this section. Answer any **THREE**.

1. (a) What are the differences between sequential approach to the product development and concurrent engineering approach? Why should the later be adopted? **(15)**
 - (b) Under what circumstances might it be appropriate to adopt a sequential engineering or hybrid approach, rather than a fully concurrent engineering approach? **(10)**
 - (c) Distinguish between models of the design process and models of designs. Give examples of 2D, 2.5D and 3D models. **(10)**

 2. (a) Differentiate 'form' and 'structure' with appropriate examples. Briefly discuss Mongian projection concept and its use in current CAD systems. **(10)**
 - (b) Give examples of structures which are fitted to array of data points and surfaces which are based on curves. Explain each of them with neat sketches. **(15)**
 - (c) Discuss some industrial applications of surface modelling. Also mention drawbacks of surface modelling. **(10)**

 3. (a) Explain why parametric representations have proved popular in computational geometry. What are the key benefits of Bezier curves? **(8)**
 - (b) Derive the equation matrix form of Bezier curves. **(15)**
 - (c) A cubic Bezier curve F defined by the points (1, 1), (2, 3), (4, 4) and (6, 1). Calculate the coordinates of the parametric mid-point of this curve and verify that its gradient (dy/dx) is $\frac{1}{7}$ at this point. Use this information to sketch the curve. **(12)**

 4. (a) Distinguish between viewing transformation and object transformations. **(17 ½)**
- A circle of radius 15 mm centered at (100, 150) is to be drawn as a series of lines on a display by a two dimensional draughting system. If maximum display tolerance is 2.0 mm determine number of line and point coordinates in the display. Consider window bounds are (40, 100) and (160, 200), and viewpoint bounds are at pixel location (0, 50), (480, 450).

IPE 409

Contd ... Q. No. 4

(b) Using object transformation technique mirror three points shown in Fig. for Q. 4(b) through a line EF.

(17 1/2)

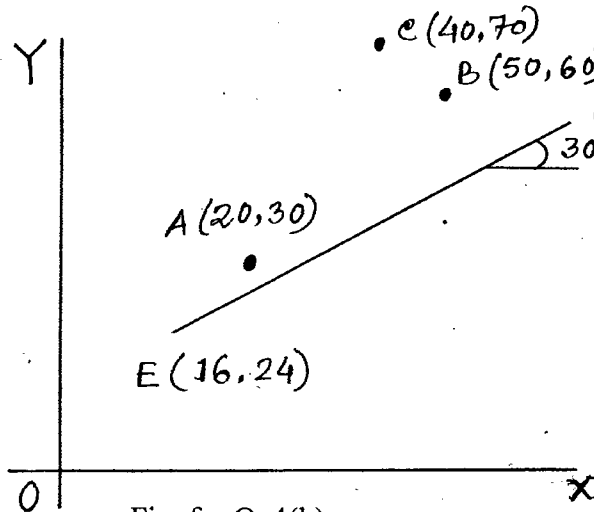

Fig. for Q. 4(b)

SECTION - B

There are **FOUR** questions in this section. Answer any **THREE**.

- 5. (a) What are the benefits of CNC machining center over CNC machine? (7)
- (b) NC machines are hardware controlled whereas CNC machines are software controlled – explain. (8)
- (c) Discuss the working principles of Carousel and Chain type ATC for a CNC machining center. (20)
- 6. (a) Tool offset is required before starting machining in CNC machining center – justify. (7)
- (b) Absolute and incremental positioning can be done in the same line of a G-code – provide example. (5)
- (c) If a machine table travels at rapid speed, how can you distinguish this travel from a linear interpolation travel at same feed rate? (8)
- (d) Write a G-code for machining the following part using any suitable tool. (15)

ALL DIMENSIONS IN MM

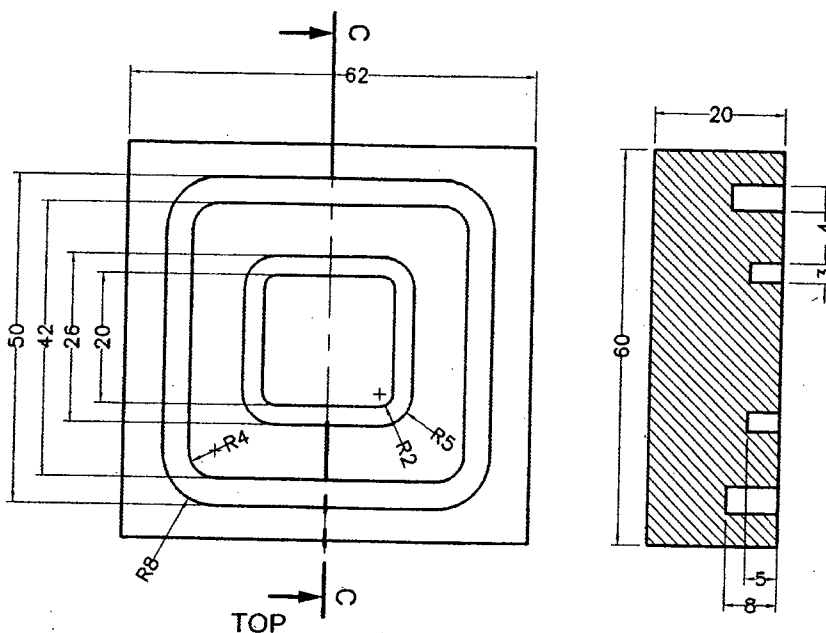

Fig for Q. 6 (d)

Section-CC

Contd P/3

IPE 409

- 7. (a) Briefly discuss the working principle of a Pallet work changer. (10)
- (b) What is the measurement mechanism of a CMM using a touch probe? (12)
- (c) Write a G-code for the following circular part using single point cutting tool. (13)

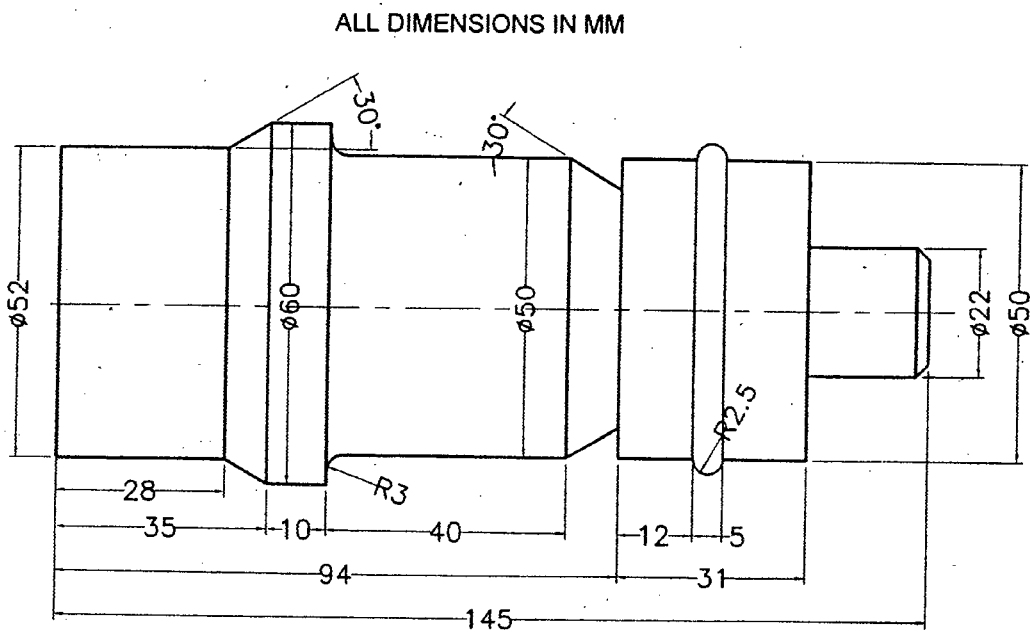

FIG. Q.7 (c)

- 8. (a) What are the key requirements for developing interactive CAD system? (7)
- (b) Discuss the importance of neutral format for data exchanger. Briefly explain history of neutral format development. (18)
- (c) What are the different sections in a DXF file? Discuss each section in brief. Provide an example of ENTITIES section for a DXF file representing a circle. (10)

Contd P/4

List of G-code for CNC Milling/Turning Operations

G-code	Description
G00	Rapid traverse
G01	Linear interpolation
G02	Clockwise circular interpolation
G03	Counterclockwise circular interpolation
G20	Inch data input
G21	Metric data input
G28	Automatic return to the reference point

G-code	Description
G40	Tool (nose) radius compensation cancel
G41	Tool (nose) radius compensation left
G42	Tool (nose) radius compensation right
G54-59	Workpiece coordinate system 1-6 selection
G90	Absolute command programming
G91	Incremental command programming
G92	Zero offset setting

G-code	Description
G50	Maximum spindle speed command
G80	End of shape designation
G81	Start of longitudinal shape designation
G82	Start of traverse shape designation

G-code	Description
G85	Call for rough bar turning cycle
G87	Call for finishing turning cycle
G96	Constant cutting speed
G97	Fixed RPM

List of M-code for CNC Milling/Turning Operations

M-code	Description
M02	End of program
M03	Spindle clockwise
M04	Spindle counterclockwise
M05	Spindle stop

M-code	Description
M06	Tool change
M08	Coolant on (spray)
M09	Coolant off
M30	End of program

SECTION – AThere are **FOUR** questions in this section. Answer any **THREE**.

1. (a) What do you mean by volatile and non-volatile memory? Briefly explain different types of ROM used in a computer system. State the differences between SRAM and DRAM. **(1+2+2)**
- (b) What do you mean by memory interleaving and pipeline control? Briefly explain the memory hierarchy and its necessities'. **(2+2+1)**
- (c) Briefly explain each of the following term: **(6)**
 (i) Swapping (ii) Overlay method (iii) Paging method
- (d) Assume that the specifications of a hard disk are given below. Calculate how many cylinders are necessary to write 100,000 records. **(7²/₃)**

[File Specification]

Record length	250 bytes
Blocking factor	8

[Specifications of a hard disk]

Number of cylinders per disk	400
Number of tracks per cylinder	19
Number of bytes per track	13,000
Block Gap	135 bytes

2. (a) What are the different types of data transfer mode? Explain in details. What do you mean by interruption? Explain (in details) different types of interruptions. **(2+3)**
- (b) Briefly discuss the advantages and disadvantages of a client/server architecture. What is difference between Horizontal function distribution and Vertical function distribution? **(3+2)**
- (c) Explain the following terms in brief: **(6)**
 (i) Bathtub Curve
 (ii) turn-around time
 (iii) Response time
- (d) What do you mean by MTBF and MTTR? Briefly discuss about fail-safe, fail-soft and fool-proof reliability design method. **(7²/₃)**

CSE 441 (IPE)

3. (a) Explain in details the following two transmission protocols: (4+5)
(i) Basic Procedure (ii) HDLC Protocol
- (b) Explain in details various error control methods used in network transmission. (4²/₃)
- (c) Briefly discuss the following communication units: (10)
(i) Gateway (ii) Router (iii) Bridge (iv) Hub (v) Repeater
4. (a) Explain in details about CSMA/CD and Token Passing for access control of LAN.
What do you mean by FDM, TDM and WDM? (2+3)
- (b) Write short notes on each of the following: (6)
(i) ISDN
(ii) ATM
(iii) ADSL
- (c) State the comparison among Simplex, Half-duplex and Full-duplex transmission method. Explain in details about Bit Synchronization, Character Synchronization and Block Synchronization. (9)
- (d) Consider the following Instruction Mix. (3²/₃)

Instruction Group	Execution Speed (microsecond)	Frequency of appearance
A	0.1	40%
B	0.2	30%
C	0.5	30%

Now calculate the average instruction execution time in second. Also calculate the MIPS.

SECTION – B

There are **NINE** questions in this section. Answer any **SEVEN**.

5. (a) Represent the decimal number "-17" in two's complement form. (3)
(b) Write the BCD Code representation of the decimal number 98. (1)
(c) Briefly explain recursive and reusable program structures. (6)
6. (a) Explain the "Transaction Partitioning" design technique. (4)
(b) Derive the hexadecimal representation of the decimal number 82. (6)

CSE 441 (IPE)

7. (a) Using a combination of "arithmetic" and "logical" shift operations, convert the decimal number -2 to the decimal number 6. (Assume 4-bit binary representation of the numbers during the shift operation/s). (2)
- (b) Explain the characteristics of the following process models: (8)
- (i) Waterfall model
 - (ii) Spiral Model
 - (iii) Prototyping model
8. (a) Briefly explain Integration Test. (2)
- (b) Suppose the order of elements stored in an array is: 10, -2, 7, 9, 28, 12. (8)
- Sort the array using "Bubble Sort" so that the elements are stored in descending order. Show each step of your simulation.
9. (a) Differentiate between Array and List. (5)
- (b) Describe the flow of "Internal Design" phase of software development. (5)
10. (a) Explain the "Error-Planting Model". (4)
- (b) Implement a "Queue" using two "Stacks". (6)
11. (a) Differentiate between "Black-box" and "White-box" testing. (2)
- (b) Consider the array A: 1, 3, 8, 12, 23, 26 (8)
- Using "Binary Search" algorithm, find 23 in A. Show each of the comparisons made in the process of searching 23 in A.
12. (a) Define "Round-off Error". (2)
- (b) Consider the base code "9415". The weights of the digits from ones digit to thousands digit are 6, 2, 1 and 5, respectively. Obtain the value of the "check digit" using check digit method. (4)
- (c) Briefly explain the concept of "Closed Subroutine". (4)
13. (a) What is a compiler? Describe the procedures of a compiler. (7)
- (b) "C is a procedural language" – explain. (3)
-