

*Amrumb*  
06.10.13

L-1/T-2/EEE

Date : 06/10/2013

BANGLADESH UNIVERSITY OF ENGINEERING AND TECHNOLOGY, DHAKA

L-1/T-2 B. Sc. Engineering Examinations 2011-2012

Sub : **MATH 257** (Ordinary and Partial Differential Equations)

Full Marks: 210

Time : 3 Hours

USE SEPARATE SCRIPTS FOR EACH SECTION

The figures in the margin indicate full marks.

**SECTION - A**

There are **FOUR** questions in this section. Answer any **THREE**.

Symbols used have their usual meaning.

1. Solve the following differential equations:

(a)  $\left(x \cos \frac{y}{x} + y \sin \frac{y}{x}\right)y - \left(y \sin \frac{y}{x} - x \cos \frac{y}{x}\right)x \frac{dy}{dx} = 0$  (12)

(b)  $\frac{dy}{dx} + \frac{xy}{1-x^2} = x\sqrt{y}$  (12)

(c)  $(2x - 2y + 5)\frac{dy}{dx} = x - y + 3$  (11)

2. (a) Prove that  $x^h y^k$  is an integrating factor of the equation

$(pydx + qxdy) + x^m y^n (rydx + sxdy) = 0$  if  $\frac{h+1}{p} = \frac{k+1}{q}$  and  $\frac{h+m+1}{r} = \frac{k+n+1}{s}$ . (12)

(b) An RL circuit has emf given (in volts) by  $3\sin 2t$ , a resistance of 10 ohms, an inductance of 0.5 henry, and an initial current of 6 amperes. Find the current in the circuit at any time  $t$ . (11)

(c) Solve:  $(x^2 + y^2 + x)dx + xydy = 0$ . (12)

3. Solve the following:

(a)  $(D^2 + 6D + 5)y = x^2 + e^{-x}$  (11)

(b)  $(D^2 - 4D + 4)y = 8x^2 e^{2x} \sin 2x$  (12)

(c)  $(1 + 2x)^2 \frac{d^2 y}{dx^2} - 6(1 + 2x) \frac{dy}{dx} + 16y = 8(1 + 2x)^2$  (12)

4. (a) Using the method of variation of parameters solve the differential equations

$\frac{d^2 y}{dx^2} + 9y = \sec 3x$ . (14)

(b) Solve the equation  $[xD^2 + (x-2)D - 2]y = x^3$  by the method based on factorization of the operator. (14)

(c) Solve:  $x^2 \frac{d^3 y}{dx^3} - 4x \frac{d^2 y}{dx^2} + 6 \frac{dy}{dx} = 4$ . (7)

Contd ..... P/2

**MATH 257****SECTION – B**

There are **FOUR** questions in this section. Answer any **THREE**.

5. (a) Using the method of Fröbenius solve the differential equation (20)

$$(2x + x^3) \frac{d^2 y}{dx^2} - \frac{dy}{dx} - 6xy = 0 \text{ in powers of } x.$$

- (b) Solve the following partial differential equation

$$(x - y)p + (y - z - x)q = z.$$

Find also the integral surface that satisfies the above partial differential equation and passes through the circle  $z = 1, x^2 + y^2 = 1$ . (15)

6. (a) Find the complete solution of the following partial differential equations.

(i)  $(x^2 + y^2)(p^2 + q^2) = 1$  (10)

(ii)  $p^2 = z^2(1 - pq)$  (10)

- (b) Using Charpit's method find the complete integral of the partial differential equation (15)

$$2zx - px^2 - 2qxy + pq = 0.$$

7. Solve the following higher order partial differential equations.

(a)  $(D_x^2 - 5D_x D_y + 4D_y^2)z = \sin(2x + y)$ . (11)

(b)  $(D_x^2 - 5D_x D_y + 6D_y^2)z = e^{x-y}xy$ . (12)

(c)  $(D_x^2 + D_x D_y - 6D_y^2)z = x^2 \cos(x + y)$ . (12)

8. (a) Solve the following PDE: (15)

$$\left( x^2 \frac{\partial^2 z}{\partial x^2} - 2xy \frac{\partial^2 z}{\partial x \partial y} - 3y^2 \frac{\partial^2 z}{\partial y^2} + \frac{\partial z}{\partial x} - 3 \frac{\partial z}{\partial y} \right) = x^2 y \sin(\log x^2).$$

- (b) Solve the wave equation  $\frac{\partial^2 U}{\partial t^2} = 9 \frac{\partial^2 U}{\partial x^2}$  for the displacement function  $U(x, t)$  which

satisfies the following boundary conditions: (20)

$$U(0, t) = 0, U(2, t) = 0, U(x, 0) = 20 \sin 2\pi x, U_t(x, 0) = 0.$$

-----

29.9.13

L-1/T-2/EEE

Date : 29/09/2013

BANGLADESH UNIVERSITY OF ENGINEERING AND TECHNOLOGY, DHAKA

L-1/T-2 B. Sc. Engineering Examinations 2011-2012

Sub : **HUM 127** (Sociology, Science and Technology)

Full Marks : 210

Time : 3 Hours

The figures in the margin indicate full marks.

USE SEPARATE SCRIPTS FOR EACH SECTION

**SECTION – A**

There are **FOUR** questions in this Section. Answer any **THREE**.

1. (a) Explain how sociologists think themselves away from the familiar routine of daily lives through sociological imagination. (10)  
(b) What is meant by social norm? Explain the relationship between social norms and social sanctions for developing the patterns of conformist behaviour of a society. (15)  
(c) Briefly explain the functionalist theoretical perspective of sociology. (10)
2. (a) What are the elements of culture? How is globalization influencing changes in each of the elements of culture? Explain with some practical examples. (15)  
(b) What is dominant ideology? How does conflict viewer examine the influence of dominant ideology in the cultural practices of a society? (20)
3. (a) How does socialization shape human behaviour? Critically evaluate the roles of family and peer group as the agents of socialization. (10)  
(b) What is social stratification? Explain the caste system of social stratification. (10)  
(c) Critically discuss Karl Marx's theory of class differentiation. (15)
4. Write short notes on any three of the following: (35)  
(a) Types of socialization  
(b) Mass media  
(c) Poverty reduction and Bangladesh  
(d) Dependency theory.

**SECTION – B**

There are **FOUR** questions in this Section. Answer any **THREE**.

5. (a) How do you define natural greenhouse and man-made green house. (8)  
(b) Define physical environment. Briefly discuss how the socio-economic development depends on physical environment. (15)  
(c) What are the negative impacts of global warming? (12)

Contd ..... P/2

**HUM 127**

6. (a) What do you mean by crude birth-rate and crude death rate? What are the socio-cultural factors that influence population growth? (10)
- (b) What do you mean by cities' city? What problems do megacities have and how can those problems be tackled? (15)
- (c) Briefly discuss the major pollution issues in Dhaka city. (10)
7. (a) Show the differences between deviance and crime. What are the types of deviance? Give example from our society? (15)
- (b) Define juvenile delinquency. Identify the factors affecting juvenile delinquency in our society. (20)
8. Write short notes on any THREE of the following: (35)
- (a) The impacts of capitalism
  - (b) The sources of social change
  - (c) The evolution of pollution prevention
  - (d) The impacts of industrial revolution
-

**SECTION - A**There are **FOUR** questions in this section. Answer any **THREE**.

1. (a) Derive the integrated rate equation for the reaction  $2A \rightarrow P$  and show that the half-life for such a reaction is not directly proportional to initial concentration. (8+4)
- (b) For a first order reaction, the half of the reactant is dissociated in 500 seconds. At what time, one fourth of the reactant will remain unreacted? (6)
- (c) Discuss the graphical and differential methods for the determination of order. (12)
- (d) Define activation energy and explain its application using a diagram. (5)
2. (a) State and explain <sup>→ve</sup> Chatelier Principle. What is the effect of pressure and catalyst on the equilibrium constant (K) of a reaction at equilibrium. Illustrate with example. (2+4+4+4)
- (b) Derive a mathematical model showing the relationship between equilibrium constant and temperature. Show its application. (10+2)
- (c) 35%  $N_2O_4$  is dissociated at 100 °C. If the total pressure is 1.5 atm., find out the values of  $K_p$  and  $K_c$ . (9)
3. (a) What do you understand by buffer solution? Classify and show their mode of operation. (2+3+4)
- (b) Derive the rate law for a first order reaction being opposed by another first order reaction. (8)
- (c) Define effective nuclear charge. Explain why in the second period of the periodic table the effective nuclear charge of elements increases from left to right? (4+5)
- (d) From each of the following pairs, indicate which has the larger size and why? (9)
- (i)  $O^{2-}$  or  $F^-$  (ii)  $Sr^{2+}$  or  $Ca^{2+}$
4. (a) What is the origin of quantization of energy? How the concept of quantization of energy for an electron in an atom was used to build the Bohr's atomic model? (4+8)
- (b) Explain how Schrödinger wave equation introduces the concept of atomic orbital? (7)
- (c) What is Pauli's exclusion principle? Explain the four quantum numbers to identify an electron in an atom. (3+7)
- (d) What is the concept of standing wave in an atomic system? (6)

**CHEM 101**

**SECTION - B**

There are **FOUR** questions in this section. Answer any **THREE**.

5. (a) Define saturated solution, un-saturated solution and super-saturated solution. Which of the above solutions should have dynamic equilibrium point? Why the others do not have equilibrium point? (10)
- (b) Why is not the super-saturated solution of an exothermic solute prepared? Describe the preparation of a super-saturated solution. (8)
- (c) Define absorption coefficient and discuss the effects of the following factors on the absorption coefficient of a gas in water: (10)
- (i) Temperature, (ii) Nature of solute and solvent and (iii) Presence of salt
- (d) How the evolution and absorption of heat take place during the dissolution of a solid in water? (7)
6. (a) What are colligative properties? Why are they called properties of dilute solution? (4)
- (b) What do you understand by lowering and relative lowering of vapour pressure? Why an aqueous solution of sugar has got lower vapour pressure than that of its solvent? (11)
- (c) Define boiling point of a liquid. Derive a mathematical relation correlating molecular weight of a solute and the boiling point of its solution. (10)
- (d) What is ebullioscopic constant? The boiling point of an aqueous solution of sugar containing 1.5 g sugar in 100 g solvent is 101.5 °C. Calculate the ebullioscopic constant of the solvent. (10)
7. (a) What is phase rule? Illustrate the terms involved therein. (10)
- (b) Draw the phase diagram of sulphur and describe it with the help of phase rule. (20)
- (c) Why quadruple point in a phase diagram of sulphur does not exist? (5)
8. (a) Predict and draw the geometry of the following (3×4=12)
- (i)  $\text{NH}_4^+$  (ii)  $\text{XeF}_4$  (iii)  $\text{I}_3^-$  (iv)  $\text{AlCl}_4^-$
- (b) What kind of limitations of Valence Bond Theory insisted to consider Molecular Orbital Theory? (7)
- (c) Give the orbital diagram and electronic configuration of CO according to molecular orbital theory. What is bond order of CO? Is the molecule diamagnetic or paramagnetic? (8)
- (d) Draw the potential energy diagram of a simple diatomic molecule. With the help of potential energy diagram define the term (i) bond length and (ii) bond dissociation energy. (8)
-

**SECTION - A**

There are **FOUR** questions in this section. Answer any **THREE**.

1. (a) Derive the expressions of voltage  $v_s$ , current  $i$ , and impedance  $Z$  for the circuit shown in Fig. 1(a). Assume, the voltage across the capacitor  $C$ ,  $v_c = V_m \sin \omega t$ . (18)  
 (b) In a series ac circuit, the current is found to be  $i = \sin(1000t + 45^\circ)$  for an applied voltage  $v = 100 \sin(1000t)$ . One element of the circuit is an inductor of 10 mH. Determine the values of the other elements. (17)
  
2. (a) Determine the effective value of the voltage for the wave shape shown in Fig. 2(a). (17)  
 (b) The equivalent circuit of a transformer referred to the primary side is given in Fig. 2(b). Determine the Thevenin's equivalent circuit for the terminals A & B. Also determine the power consumed by a 100  $\Omega$  resistor if it is connected between the terminals A & B. (18)
  
3. (a) Analytically show that the maximum voltage across the capacitor is obtained at a lower value of the capacitance than the capacitance at resonance when resonance is achieved in a series R-L-C circuit by varying capacitance. (17)  
 (b) Comment on the resonance points and determine the value of  $X_C$  to achieve parallel resonance in the circuit shown in Fig. 3(b) by varying  $C$  at (i)  $R_L = 6 \Omega$ ,  $X_L = 8 \Omega$  and (ii)  $R_L = 18 \Omega$ ,  $X_L = 24 \Omega$ . (18)
  
4. (a) For the circuit shown in Fig. 4(a), the applied voltage  $v = 100 \sin 1000t + 50 \sin(3000t - 45^\circ) + 20 \sin(5000t - 60^\circ)$ . What is the expression of  $i$ ? Determine the power supplied by the voltage source. (17)  
 (b) Determine the Thevenin's equivalent circuit between the terminals A & B for the magnetically coupled circuit shown in Fig. 4(b), where  $K$  is the coefficient of coupling. (18)

**EEE 105**

**SECTION - B**

There are **FOUR** questions in this section. Answer any **THREE**.

5. (a) What is a transient voltage or a transient current? How does transient conditions arise in a system. (5)
- (b) When maximum transient condition will happen with zero initial condition for a highly inductive load when the switch is closed at  $t = 0$ . Justify your statement analytically. (10)
- (c) Find the over all response of  $i(t)$  after switching for the circuit shown in Fig. Q. 5(c). (20)

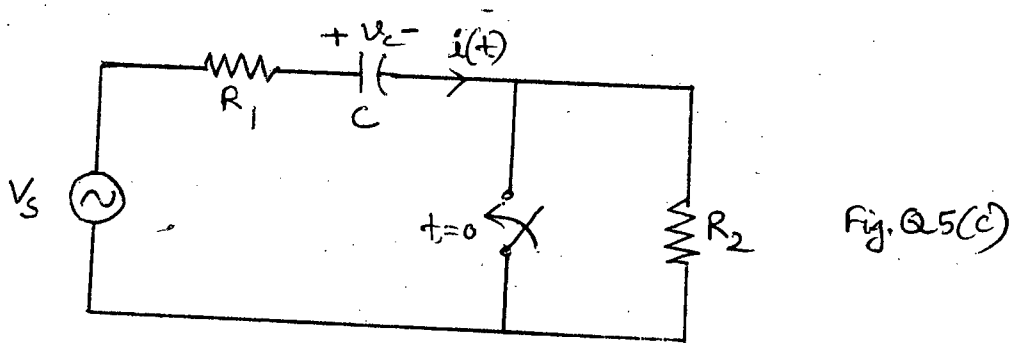

Hence,  $v_s(t) = 100\sqrt{2} \sin(\omega t + \pi/2)$ ,  $\omega = 314 \text{ rad/sec}$ ,  
 $R_1 = R_2 = 5\Omega$ , and  $c = 500 \mu\text{F}$ .

6. (a) Explain phase sequence checking using a circuit consisting of a capacitor, a resistor and a voltmeter with the help of phasor diagram. (10)
- (b) Determine the line currents for the unbalanced load where the supply voltage is 212 volt. (15)

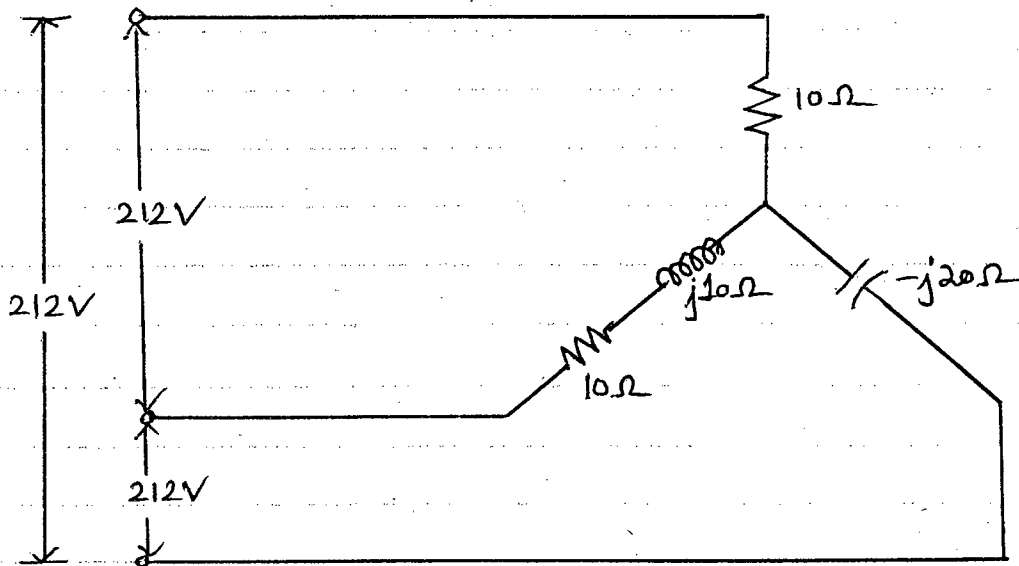

Fig Q.6(b)

- (c) How a bandpass filter can be constructed connecting a lowpass and a highpass filter in cascade? Explain, what should be the circuit condition to have good voltage coupling? (10)



**EEE 105**

7. (a) Design both T-and  $\pi$ -section lowpass filters of constant-k' type whose zero frequency characteristic impedance is  $600 \Omega$  and a cut off frequency of 940 cycles. Draw the circuit arrangement for each. (10)
- (b) Show analytically that the attenuation at passband is zero for constant T-or  $\pi$ -section filter. Consider low-pass filter only. (10)
- (c) Comment on the type of filter for the circuit shown in Fig. Q. 7(c) by determining the transfer function. Calculate also the cut-off frequency. (15)

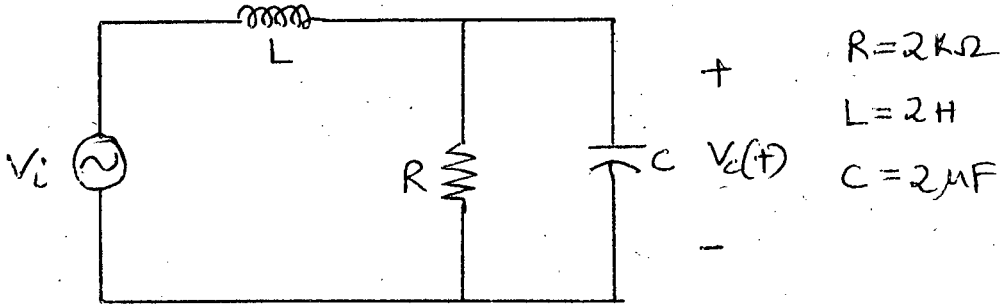
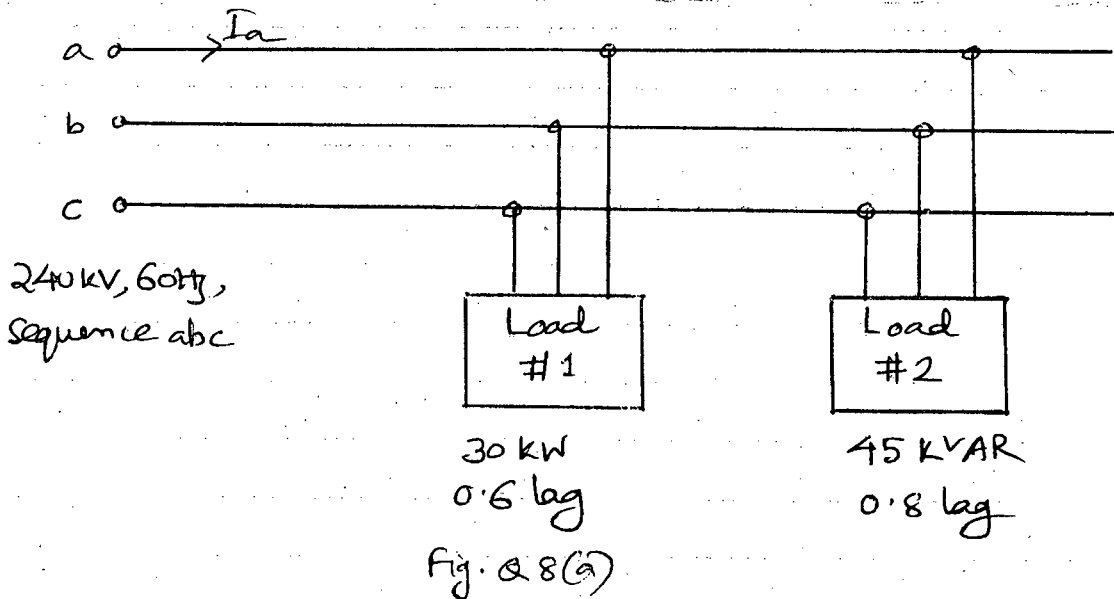

Fig. Q. 7(c)

8. (a) Two balanced loads are connected to a 3- $\phi$  supply as shown in Fig. Q. 8(a). Determine (10)
- Total power absorbed by loads.
  - Line current.
  - Capacitance required to raise the power factor to 0.9 lagging. Assume  $\Delta$ -connected capacitor bank.



- (b) Show that the total instantaneous power of a 3- $\phi$  balanced system is constant and is given by  $p(t) = \sqrt{3} V_L I_L \cos \theta$ . (15)
- Symbols have their usual meaning.
- (c) A  $\Delta$ -connected load has  $(9-j6) \Omega$  in each phase and a Y-connected load has  $(6+j8) \Omega$  in each phase. They are connected in parallel across a 3- $\phi$  line voltage of 230 V. Calculate the total line current, power consumed and the power factor of the combination. (10)

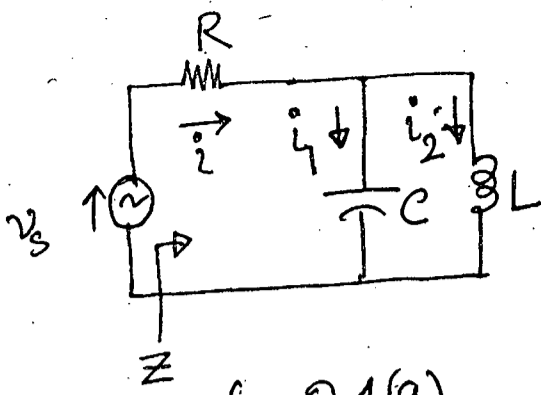

Fig. for Q.1(a)

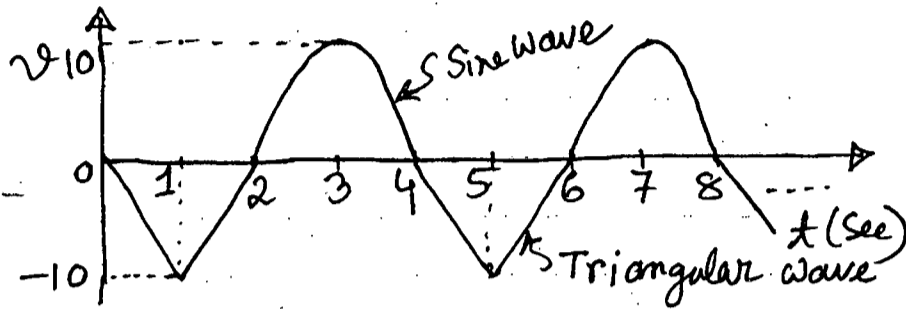

Fig. for Q.2(a)

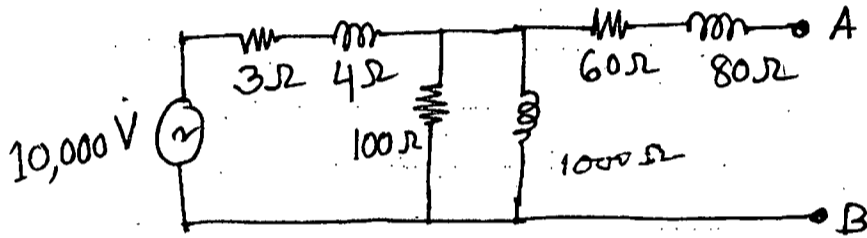

Fig. for Q.2(b)

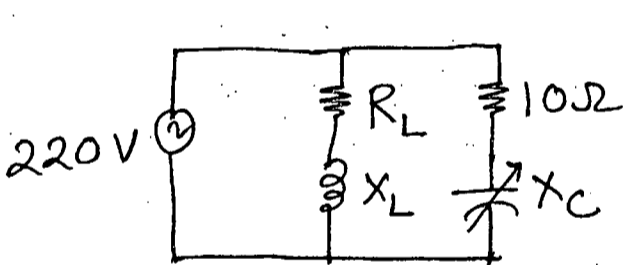

Fig. for Q.3(b)

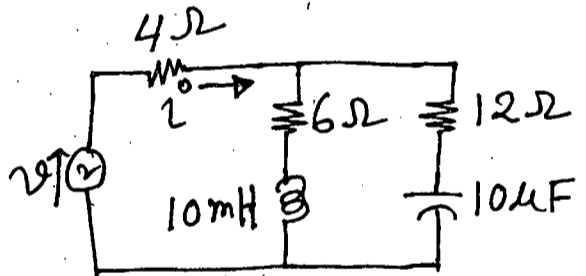

Fig. for Q.4(a)

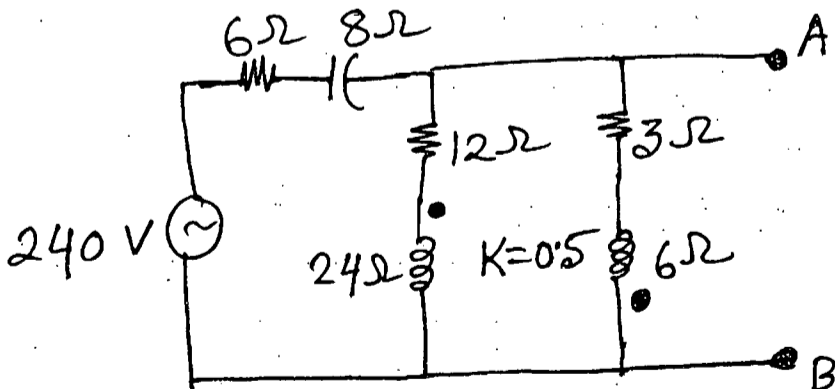

Fig. for Q.4(b)

ARkom

L-1/T-2/EEE

Date : 24/07/2013

BANGLADESH UNIVERSITY OF ENGINEERING AND TECHNOLOGY, DHAKA

L-1/T-2 B. Sc. Engineering Examinations 2011-2012

Sub : **PHY 165** (Electricity and Magnetism, Modern Physics, Mechanics)

Full Marks : 210

Time : 3 Hours

The figures in the margin indicate full marks.

USE SEPARATE SCRIPTS FOR EACH SECTION

**SECTION – A**

There are **FOUR** questions in this section. Answer any **THREE**.

1. (a) State the postulates of special theory of relativity. (4)  
(b) Derive the equations of Lorentz transformation. Show that for values of  $V \ll c$  Lorentz transformation reduces to Galilean transformation. (22)  
(c) Consider S and S' are two frames of reference, where S is stationary and S' is moving with a velocity 30 m/s. An observer in S' observes that two events occur at the same time but are separated in space. An observer in S observes that two events occur at different times. If the distance separation in S' be 10 m; what is the time separation in S? (9)
2. (a) Briefly describe a photo-electric cell. (12)  
(b) What is de-Broglie hypothesis? Derive an expression for wavelength of matter waves. (13)  
(c) Light of wavelength 4000 Å is incident on (i) nickel surface of work function 4.5 eV and (ii) potassium surface of work function 2 eV. Find out the maximum velocity of the emitted electrons in each cases. (10)
3. (a) Explain the terms mass defect and binding energy of a nucleus. (6)  
(b) Consider 200 MeV energy is released per fission reaction and 25 MeV energy is released per fusion reaction. Which is more dangerous in between atom bomb and hydrogen bomb of same size, explain? (9)  
(c) What is average life of a radioactive element? Obtain an expression for the average life of a radioactive substance. (20)
4. (a) State and explain Coulomb's law and Gauss's law of electrostatics. (8)  
(b) Using Gauss's law obtain an expression for electric field E at point P at a distance r from the centre of a uniformly charged non-conducting sphere of radius R. In case of (19)
  - (i) Outside ( $r > R$ )
  - (ii) Inside ( $r < R$ )
  - (iii) Surface ( $r = R$ ) of the sphereAlso draw schematically E(r) as function of distance.

Contd ..... P/2

**PHY 165**

**Contd ... Q. No. 4**

(c) A cylinder is immersed in a uniform electric field as shown in the figure 4(c). Calculate the total electric flux for this closed surface. (8)

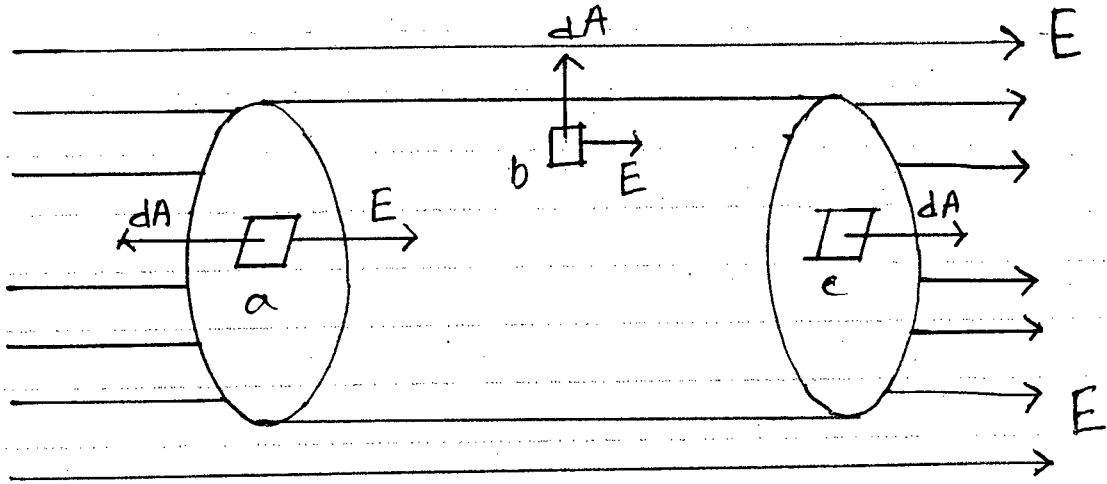

Fig. 4(c)

**SECTION - B**

There are **FOUR** questions in this section. Answer any **THREE**.

5. (a) Write down the four Maxwell's equations of electromagnetism. Explain the physical significance of any two of them. (10)
- (b) State Lenz's law for the direction of the induced emf. does Kirchoff's loop rule lose its validity in case of electromagnetic induction? In what condition it becomes valid? (8)
- (c) Figure 5(c) shows a cylindrical conducting wire of radius R carries current I distributed uniformly across the cross-section. Using Amphere's law calculate the magnetic field B at a distance r from the centre of the wire for the cases (17)
  - (i) Outside ( $r > R$ )
  - (ii) Inside ( $r < R$ )
  - (iii) Surface ( $r = R$ ) of the wire

Also draw schematically B(r) as a function of r.

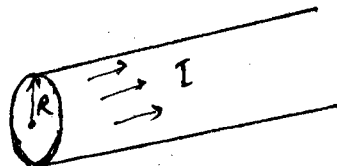

Fig. 5 (c)

**PHY 165**

6. (a) Define electric potential. (4)
- (b) A spherical drop of water carrying a charge of  $3 \times 10^{-6}$  C has a potential of 500 volts at its surface. (12)
- (i) What is the radius of the drop?
- (ii) If two such drops of the same charge and radius combine to form a single spherical drop, what is the potential at the surface of the new drop formed?
- (c) Define self inductance of an electric circuit. (4)
- (d) A circuit contains a self inductor of inductance L and a resistor of resistance R placed in series with a cell of emf  $\epsilon$ . (15)
- (i) Obtain expression for growth of current in the circuit.
- (ii) Draw schematically current Vs time in this case.
- (iii) What is time constant of this circuit?
7. (a) Define angular momentum of a system of particles. Show that the total angular momentum about an origin is the sum of the angular momentum of the centre of mass about that origin and the angular momentum of the system about the position of the centre of mass. (8)
- (b) Consider a particle of mass m moving in a central force field described by the potential energy V(r). (18)
- (i) Write down the lagrangian of the particle in plane polar co-ordinates.
- (ii) Derive the equation of motion of the particle.
- (iii) Finally, derive the differential equation of the orbit under an attractive inverse-square law.
- (c) A satellite has its largest and smallest orbit speeds given by  $V_{\max}$  and  $V_{\min}$  respectively. Prove that the eccentricity of the orbit in which the satellite moves is equal to  $\frac{V_{\max} - V_{\min}}{V_{\max} + V_{\min}}$ . (9)
8. (a) A particle of mass is confined in a field free region between impenetrable walls at  $x = 0$  and  $x = a$ . (28)
- (i) Derive the time independent Schrödinger wave equation for a particle.
- (ii) Show that the stationary energy levels of the particles are given by  $E_n = \frac{n^2 h^2}{8 ma^2}$ .
- (iii) Draw the energy level diagram for the particle.
- (iv) Find the normalized wave function for the particle.
- (v) Calculate the expectation value of  $x$ ,  $x^2$ , and  $p^2$ .
- (vi) Finally find  $\sigma_x$  and  $\sigma_y$ .
- (vii) Is their product consistent with uncertainty principle?
- (b) Derive the equation of continuity for fluids. Show that the probability current density for a free particle is equal to the product of its probability density and its speed. (7)

-----