

07.06.14  
S. S. H.

L-4/T-2/WRE

Date : 07/06/2014

BANGLADESH UNIVERSITY OF ENGINEERING AND TECHNOLOGY, DHAKA

L-4/T-2 B. Sc. Engineering Examinations 2011-2012

Sub : **WRE 423** (River Engineering and Flood Mitigation)

Full Marks : 210

Time : 3 Hours

The figures in the margin indicate full marks.

USE SEPARATE SCRIPTS FOR EACH SECTION

**SECTION – A**

There are **FOUR** questions in this section. Answer any **THREE**.  
Assume reasonable data if not given. Sketch wherever necessary.

1. (a) Define the following terms used in River Engineering (15)
  - (i) Anabranching stream
  - (ii) Dominant discharge
  - (iii) Channel pattern
  - (iv) Bed form
  - (v) Canalization
- (b) Explain why transverse flow in a river bend occurs. (8)
- (c) A meandering river channel of radius of curvature 3 km has a bankful flow area of  $1000 \text{ m}^2$  and longitudinal slope is 1 m in 3 km. Calculate (12)
  - (i) Transverse gradient.
  - (ii) the channel forming discharge
2. (a) Express the idealized longitudinal profile of a river as a exponential decay function in (x, z) plane. Given that  $S_0$  is the initial slope and  $\alpha$  is a slope reduction coefficient. (10)
- (b) Discuss the various types of stream bank deposition of alluvial rivers. According to USACE, what are the various causes of erosion based on moisture content within river bank? (15)
- (c) Bankful discharge of the river Jamuna is  $48,000 \text{ m}^3/\text{s}$ . Calculate the hydraulic geometry and average velocity of the river. Assume reasonable values of the exponents and coefficients. (10)
3. (a) Sketch a typical Shield's diagram and mention its salient features. Also write its use in practice. (10)
- (b) The following hydraulic data are available for construction of a circular bridge pier of diameter 1.5 m: (15)
  - Discharge:  $1500 \text{ m}^3/\text{s}$
  - Average width: 350 m
  - Approaching flow depth: 3.0 mCalculate the scour depth.
- (c) Name the various types river training and bank protection techniques. What types of protection techniques are commonly used in Bangladesh? Answer with sketches. (10)
4. (a) For a river Ganges, following data are given: (20)
  - Design discharge =  $40,000 \text{ m}^3/\text{s}$
  - Highest Flood level = 9.5 m PWD
  - Average Water Level = 5.5 m PWD
  - Low water level = 2.5 m PWD
  - Bed material size = 0.17 mmDesign an impermeable groyne. Assume reasonable data for your design, if not given.

Contd ..... P/2

**WRE 423**

**Contd ... Q. No. 4**

- (b) Discuss briefly the causes of deterioration of waterways in Bangladesh. How the waterways can be improved? (7)
- (c) Write briefly about the following: (8)
  - (i) Local and Embankment scour
  - (ii) Confluence and bifurcation

**SECTION – B**

There are **FOUR** questions in this section. Answer any **THREE**.

- 5. (a) Discuss the main causes and types of floods in Bangladesh. (12)
- (b) Describe the main causes of failure of an earthen dam/levee with neat sketches. (12)
- (c) Distinguish between *flood water* and *storm water*. (11)
  
- 6. (a) What are the advantages and limitations of using reservoir as a flood mitigation measure? (12)
- (b) What are the general design criteria in designing earthen dams/levees? (12)
- (c) Explain why seepage analysis is important in designing earthen dams/levees? (11)
  
- 7. (a) What is flood risk assessment? How does flood risk is estimated? (11)
- (b) What are the direct and indirect damages of flood? What are the different ways to assess flood damages? (12)
- (c) Construction of a levee is under consideration for a river reach vulnerable to flood damages. The estimated damages from various river stages and cost of levee protection below the given stages are given below. The return periods of the flood at midnight of the interval are 10, 15, 25, 30, 75, 150 and 300 years, respectively. Select the most satisfactory river stage for the design of the levee. (12)

Peak Stage (m)	Total damage below indicated stage (Million \$)	Project cost (Million \$)
6.0	0	0.4
6.5	4	0.6
7.3	10	0.8
8.0	20	1.0
8.5	32	1.3
9.1	45	1.6
9.7	60	1.8
10.3	80	2.0

- 8. (a) Describe various flood action plans that have been undertaken in Bangladesh. (10)
- (b) Write down the different measures to mitigate urban flood. (5)
- (c) Elaborate how the following measures help to mitigate flood damages. (5×4=20)
  - (i) Flood Proofing
  - (ii) Dredging and Channel Improvement
  - (iii) Watershed/Land Management
  - (iv) Flood Hazard Mapping

-----

**SECTION – A**

There are **FOUR** questions in this section. Answer any **THREE**.

Symbols have their usual meaning.

1. (a) State the importance of professional practices and communications. (7 ½)  
 (b) List the most significant scientific and engineering achievements in the 21st Century. (7 ½)  
 (c) State the purpose of code of ethics and list the Code of Ethics prescribed by the Institution of Engineers, Bangladesh (IEB). (8 ⅓)
  
2. (a) Briefly state the requirements and challenges of engineering profession. (7 ½)  
 (b) State how does the profession of engineering differ from other professions in several ways. (7 ½)  
 (c) Describe the major functions of engineering, and also state the characteristics as well as the responsibilities of professional engineers. (8 ⅓)
  
3. (a) Why professional registration is important for engineers? (7 ½)  
 (b) Briefly describe the purpose of a project proposal. State the content of a typical proposal for a consulting project. (7 ½)  
 (c) What is project cycle? Show a typical project cycle incorporating project planning, design, implementation, feedback, etc processes with the help of a neat sketch. (8 ⅓)
  
4. (a) What is meant by Industrial Revolution? 'Industrial Revolution marks a major turning point in history' – explain by mentioning its contribution in different areas. (6)  
 (b) What are the different forms of oral and written communications? For developing communication skills, what types of resources the engineers should be acquainted with? (6)  
 (c) Why conversation and speaking skills are essential for engineers? List the guidelines for effective speaking. (6)  
 (d) Briefly describe the procedures and the guidelines for effective public meeting. (5 ⅓)

**WRE 421**

**SECTION - B**

There are **FOUR** questions in this section. Answer any **THREE**.

5. (a) What do you mean by Professional Practice in Engineering? Who can practice professional Engineering? **(5+5)**
- (b) Write the complete version of the following abbreviation **(6)**
- (i) IMED
  - (ii) CPTU
  - (iii) TFP
  - (iv) TDS
  - (v) GCC
  - (vi) CESSM
- (c) List the various scopes and services usually undertaken by a "Water Engineer". **(7 1/3)**
6. (a) Write down the sequential steps towards preparation and implementation of an engineering work. **(7 1/3)**
- (b) Define the following contractual provisions: **(9)**
- (i) Public Private Partnership (PPP)
  - (ii) Built-operate-transfer (BOT) and Build-own-operate-transfer (BOOT)
  - (iii) Build-lease-transfer (BLT)
- (c) Give a flow diagram showing a typical contracting process. What are the contract types? **(7)**
7. (a) You need to construct a cement factory near by a river, what are items of works you have to consider? **(10)**
- (b) What are the elements of BOQ of a Standard Tender document? Give a typical BOQ sheet for a dredging work. **(4+4)**
- (c) List the data required to furnish for prospective bidder relating to a pre-qualification notice. **(5 1/3)**
8. (a) Write a typical set of clause headings under the general requirements of a specification. **(7)**
- (b) List the objectives, nature and scopes of Industrial relations (IR). Who are the parties to IR? **(6+3)**
- (c) Write the factors affecting the employee relations for an industry or enterprise. **(7 1/3)**
-

24-05-14  
S. S. Hi

L-4/T-2/WRE

Date : 24/05/2014

BANGLADESH UNIVERSITY OF ENGINEERING AND TECHNOLOGY, DHAKA

L-4/T-2 B. Sc. Engineering Examinations 2011-2012

Sub : **WRE 413** (Coastal Engineering)

Full Marks : 140

Time : 3 Hours

The figures in the margin indicate full marks.

USE SEPARATE SCRIPTS FOR EACH SECTION

**SECTION – A**

There are **FOUR** questions in this section. Answer any **THREE**.

Assume any reasonable data, if missing.

1. (a) Write down the different phases of coastal engineering works. (4 1/3)  
(b) Why coastal engineering is an important part of engineering practice. (6)  
(c) Bangladesh has unique coastal features along its coastline – describe. (7)  
(d) Draw a neat sandy beach profile and identify its different zones. (6)
2. (a) What are the factors that influence the propagation of waves. (4)  
(b) Define: (i) wave period, (ii) wave height, (iii) wave steepness, and (iv) oscillatory wave. (8)  
(c) A uniform beach has a slope of 1 : 200 (V : H). The wave period is 5.0 seconds. Find the wave length L and wave celerity C at a distance of (i) 300 m and (ii) 9000 m from the shoreline. (6 1/3)  
(d) What is wave diffraction? (5)
3. (a) What are the main differences between deep water and shallow water waves. (6)  
(b) Write down the assumptions for small amplitude surface wave theory. (3)  
(c) A wave is travelling shoreward. At a depth of  $d = 6.0$  m, the wave height is 0.80 m and wave period is 6.0 sec. Find the local horizontal and vertical velocities  $u$  and  $w$ , and acceleration  $a_x$  and  $a_z$  at an elevation of  $z = -2.0$  m below the SWL when  $\theta = (kx - \sigma t) = \frac{\pi}{3} = 60^\circ$ . (8 1/3)  
(d) Write down the differences between wave reflection and wave refraction. (6)
4. (a) Draw the pressure distribution for non-breaking wave on a vertical wall and identify its key features. (5)  
(b) Classify estuary according to tidal range, homogeneity and water circulation. (8)  
(c) A smooth faced wall ( $\lambda = 1.0$ ) with a wave height at the structure, if the structure were not there, is  $H_i = 2.0$  m, the depth of water at the structure is  $d = 6.5$  m and the wave period is  $T = 6$  sec. The angle of wave approach is  $\alpha = 60^\circ$  and the wall has a shoreward sloping face of 12 : 1 (V : H). For the non-breaking wave condition find the reduced horizontal wave forces (use Figure 1 and Figure 2). (8 1/3)  
(d) What are the long term and short term coastal sedimentation processes. (2)

**WRE 413**

**SECTION – B**

There are **FOUR** questions in this section. Answer any **THREE**.

5. (a) Show with a qualitative diagram the effect of lunar tide, solar tide and their combined effects on tide generation with different positions of moon. (5)
- (b) Briefly explain various tidal theories. Also differentiate between static and dynamic theories of tide. (8 1/3)
- (c) Describe the terms: (5)
- (i) Mean Higher High Water
  - (ii) Highest Astronomical Tide
  - (iii) Tidal Bore
  - (iv) Tidal Stream, and
  - (v) Mean Tide Level
- (d) Discuss the tidal characteristics of the Bay of Bengal in Bangladesh coastline. (5)
6. (a) With neat sketches show a typical plan of a harbor with all necessary requirements. (5)
- (b) List various components of a harbor and write down one main function of each of those components. (10 1/3)
- (c) Write short notes on (8)
- (i) Harbor of refuge
  - (ii) Ocean port
  - (iii) Free port
  - (iv) Offshore terminal
7. (a) Briefly discuss the types of mechanical dredgers. (9 1/3)
- (b) What is attendant equipment in dredging? Briefly describe two attendant equipment. (9)
- (c) Differentiate between mechanical and hydraulic dredgers. (5)
8. (a) Discuss the major functions and design considerations of (10)
- (i) Sea walls, and
  - (ii) Groins
- (b) By neat sketches show (8)
- (i) Vertical front sea wall
  - (ii) Typical beach configuration with groins
  - (iii) Reshaping rubble mound breakwater, and
  - (iv) Horizontal composite caisson breakwater
- (c) By neat sketches show the overview of failure modes of rubble mound breakwater. (5 1/3)
-

Figure 1: Nonbreaking waves ( $\lambda=1.0$ )

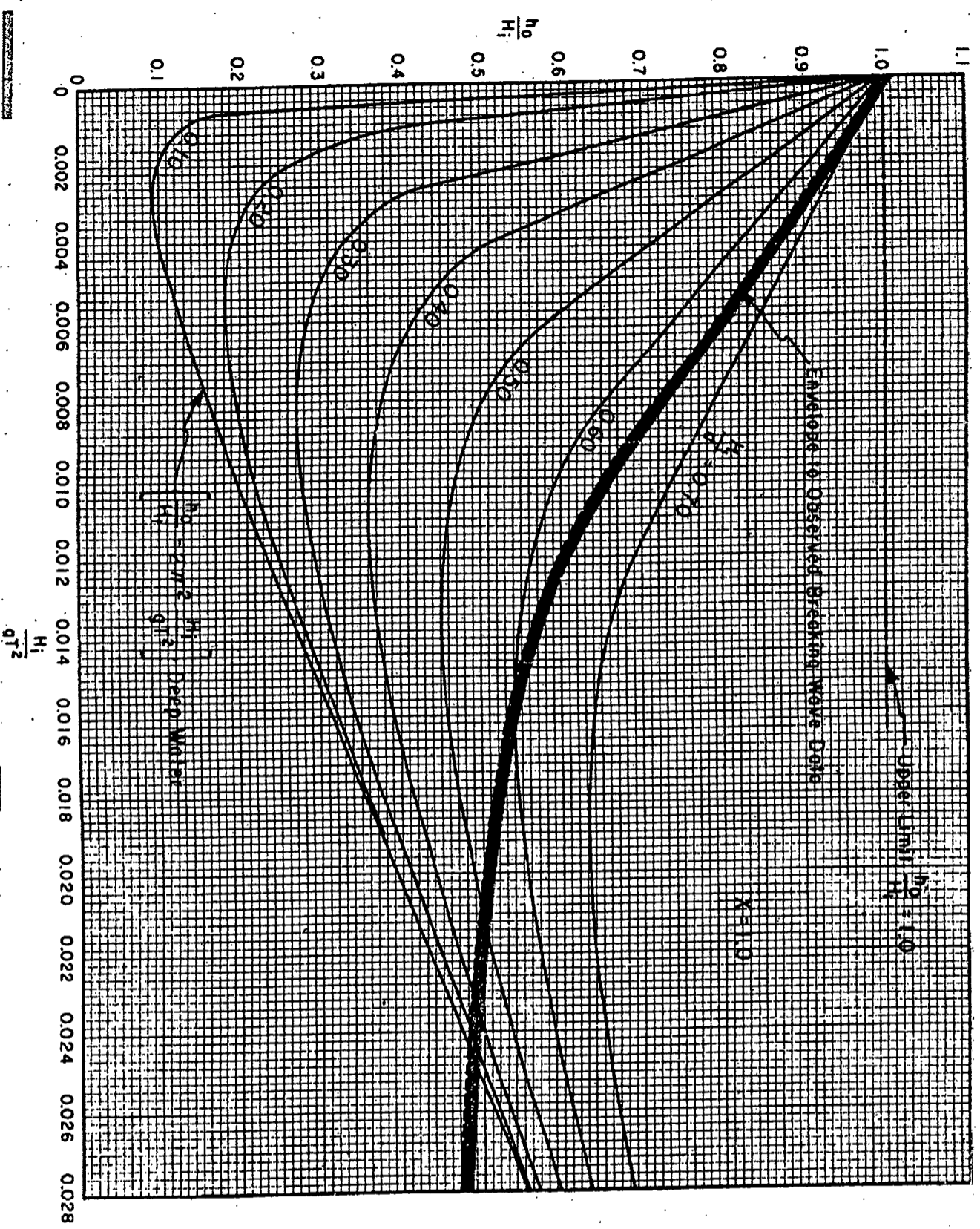

119

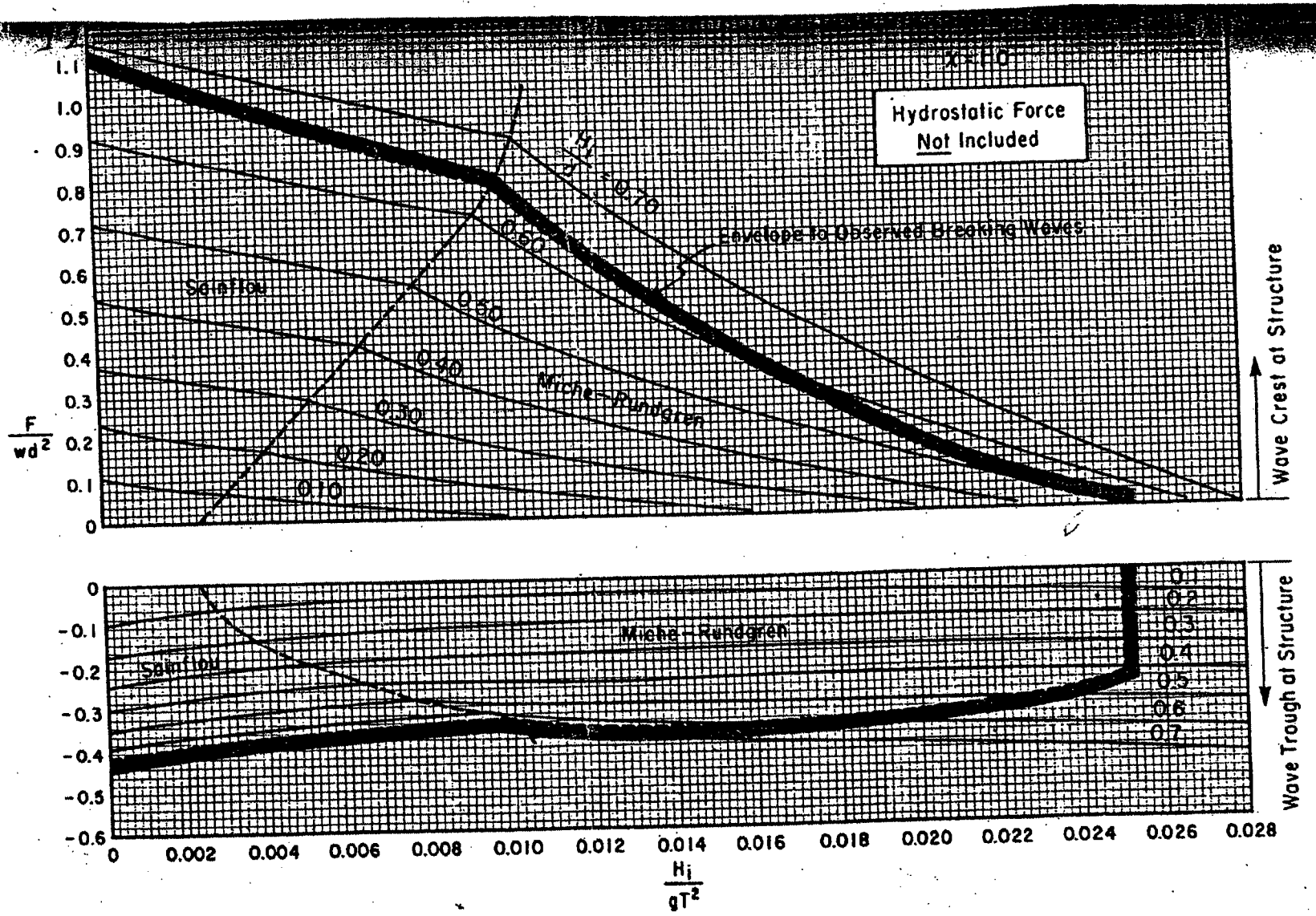

Figure 2: Nonbreaking wave forces;  $\chi = 1.0$ .



**SECTION – A**

There are **FOUR** questions in this section. Answer any **THREE**.

1. (a) What are the main causes of failure of hydraulic structures constructed on permeable foundation and what remedial measures are taken to prevent them? (6)
- (b) How does Khosla's theory differ from Bligh's theory with regard to the design of weirs on permeable foundation? (5 1/3)
- (c) The concrete floor of a weir on permeable soil is 18 m long and has sheet piles at both ends. The upstream pile line is 4 m deep and the downstream pile is 6 m deep. The weir creates a net head of 3 m. Neglecting the thickness of the weir floor, determine the uplift pressures at the junctions of the inner faces of the pile with the weir floor, by using Khosla's theory. The relevant equation is given below: (12)
- $$\phi_E = \frac{1}{\pi} \cos^{-1} \left( \frac{\lambda - 2}{\lambda} \right), \lambda = \frac{1 + \sqrt{1 + \alpha^2}}{2}, \alpha = \frac{b}{d}$$
- Where the variables have their usual meanings.
2. (a) Elaborate on (with diagrams) the uplift pressures in jump through and design of weir floor thickness. (8 1/3)
- (b) A barrage is to be constructed on an alluvial river having a flood discharge of 8500 cumecs. The relevant data are as follows: (15)
- Average river bed level = 200.0 m  
HFL (before construction of barrage) = 205.3 m  
Permissibility afflux = 1.0 m  
Lacey silt factor = 0.8
- Determine (i) the crest level of undersluices and barrage bays (ii) the waterway to pass the flood discharge (iii) downstream floor level for undersluices portion considering a retrogression of 0.5 m and 20% discharge concentration.
3. (a) State the salient points of difference between: (6)
- (i) aqueduct and syphon aqueduct (ii) silt excluder and silt extractor.
- (b) A syphon aqueduct is to be designed for the following situation: (17 1/3)

**WRE 411**

**Contd ... Q. No. 3(b)**

	<u>Canal</u>	<u>Stream</u>
Discharge, m <sup>3</sup> /s	30.0	500.0
Bed level, m	200.0	198.0
Canal FSL, m	202.0	---
Bed width, m	25.0	----
Canal side slope (H : V)	1.5 : 1	
Stream HFL, m	---	200.5

Design (i) drainage waterway, (ii) canal waterway and (iii) transitions. Also calculate the head loss through the syphon barrels assuming  $f_2 = 0.0033$  for the materials of the surface of barrel.

4. (a) Write short notes with sketches on **(3×5=15)**
- (i) critical exit gradient
  - (ii) protection works for weirs
  - (iii) uplift on bottom floor of a syphon aqueduct
- (b) The head regulator of a canal has 3 openings each 4 m wide. The water is flowing between the upper and lower gates. The vertical opening of the gate is 1.0 m. The head on the regulator is 0.5 m. If the upstream water level rises by 0.2 m, find how much the upper gates must be lowered to maintain the canal discharge unchanged. **(8 1/3)**

**SECTION – B**

There are **FOUR** questions in this section. Answer any **THREE**.

5. (a) What factors govern the selection of a suitable site for construction of a dam? **(6)**
- (b) Show with neat sketches the various storage zones of a dam reservoir. Define the following with respect to the diagram. **(6 1/3)**
- (i) Maximum Conservation level (ii) Maximum Pool level (iii) Valley storage
- (c) A contour survey of a reservoir site gives the area of 8 ha, 24 ha and 45 ha at the contour values of 46 m, 62 m and 75 m respectively. The capacity of reservoir upto 46 m elevation is found to be 34 ha-m. Determine the reservoir capacity at the elevation of 85 m. **(11)**
6. (a) State the prominent features of a chute spillway. **(4 1/3)**
- (b) What are the two fundamental processes for energy dissipation below overflow spillway? How does energy dissipation principle work, when the tail water curve lies below the  $y_2$  Curve for all discharges? **(7)**

**WRE 411**

**Contd ... Q. No. 6**

- (c) Write short notes on (i) flash board (ii) drum gate. (6)
- (d) With relevant figures show how silt pressure and uplift pressure on a gravity dam can be estimated? (6)

7. (a) Derive discharge formula over an overflow spillway. (4 1/3)

(b) For Ogee Spillway, the coefficient of discharge depends on various factors. Discuss with appropriate sketches. (8)

(c) An Ogee Spillway with vertical upstream face has the following design parameter values: (11)

- Design discharge = 6200 cumec
- Crest Length = 150 m
- Normal Reservoir level = 735 m
- Average River bed level = 650 m

The spillway consists of 7 span having a clear width of 10 m each. Thickness of each pier may be taken as 2.5 m. Determine the u/s profile of the Spillway crest. Assume any reasonable value for data not given.

8. (a) "A tension crack by itself does not fail the structure, but it leads to the failure of the structure by producing excessive compressive stress" – justify this statement with proper engineering explanation. (5 1/3)

(b) What is the function of a drainage gallery in a gravity dam? How shear strength at the base of the gravity dam can be increased? (2+2)

(c) Find out the major principal stress and the intensity of shear stress at the toe of a given dam section (Figure: 1). Use unit weight as  $23.5 \text{ kN/m}^3$ . Also assume the allowable stress of concrete to be  $2500 \text{ kN/m}^2$ . (14)

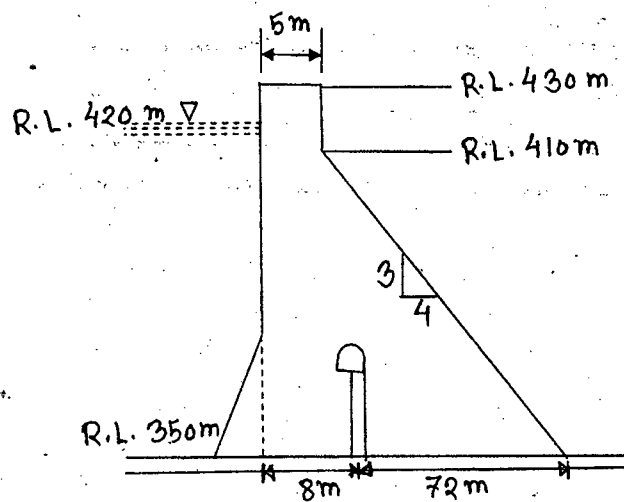
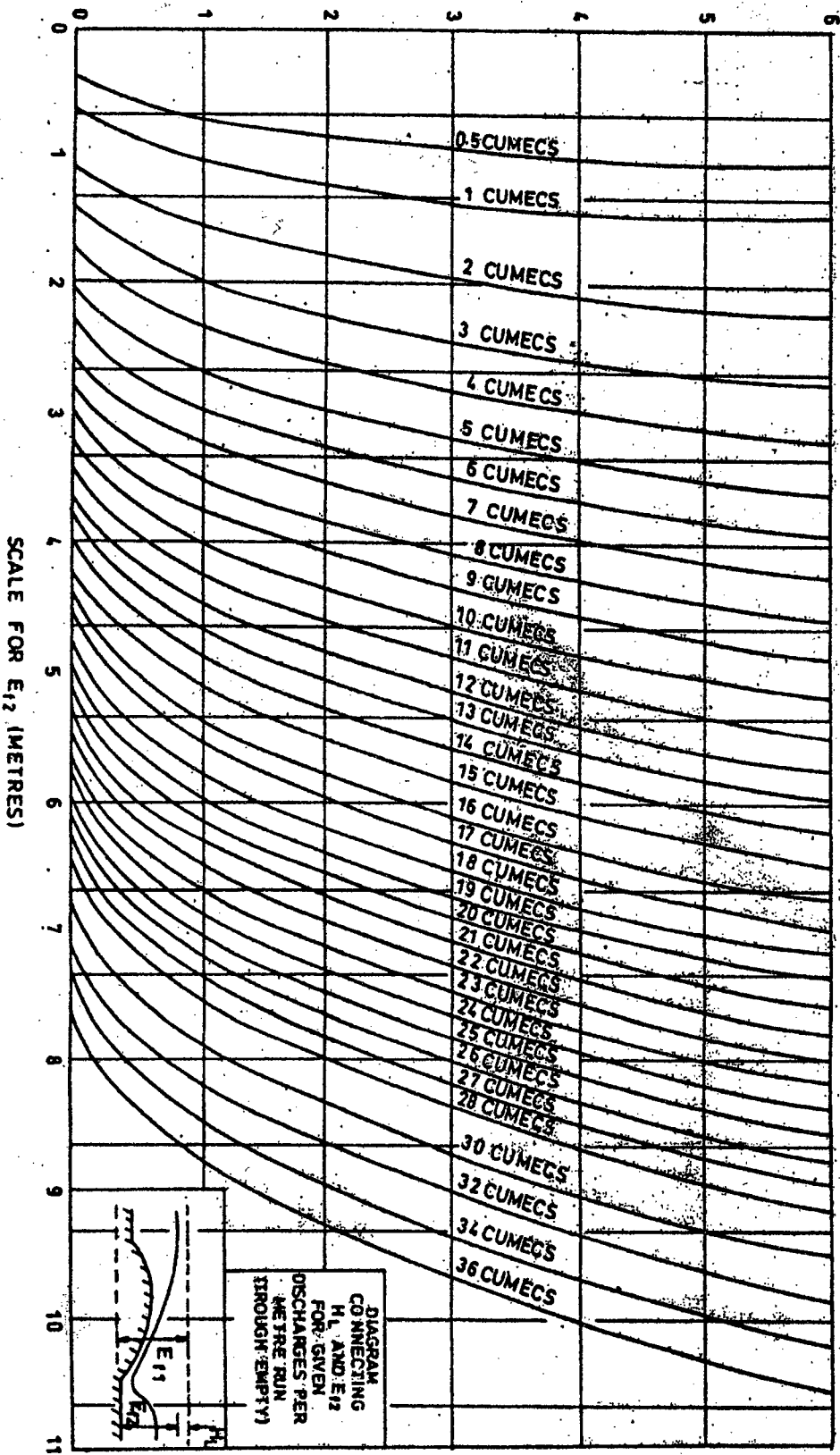
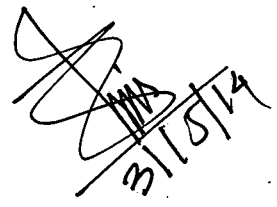

Figure: 1

SCALE FOR  $H_1$  (METRES)



For Q. No. 2(b)



L-4/T-2/WRE

Date : 31/05/2014

BANGLADESH UNIVERSITY OF ENGINEERING AND TECHNOLOGY, DHAKA

L-4/T-2 B. Sc. Engineering Examinations 2011-2012

Sub : **WRE 411** (Hydraulic Structures)

Full Marks : 140

Time : 3 Hours

The figures in the margin indicate full marks.

USE SEPARATE SCRIPTS FOR EACH SECTION

**SECTION - A**

There are **FOUR** questions in this section. Answer any **THREE**.

1. (a) What are the main causes of failure of hydraulic structures constructed on permeable foundation and what remedial measures are taken to prevent them? (6)

(b) How does Khosla's theory differ from Bligh's theory with regard to the design of weirs on permeable foundation? (5 1/3)

(c) The concrete floor of a weir on permeable soil is 18 m long and has sheet piles at both ends. The upstream pile line is 4 m deep and the downstream pile is 6 m deep. The weir creates a net head of 3 m. Neglecting the thickness of the weir floor, determine the uplift pressures at the junctions of the inner faces of the pile with the weir floor, by using Khosla's theory. The relevant equation is given below: (12)

$$\phi_E = \frac{1}{\pi} \cos^{-1} \left( \frac{\lambda - 2}{\lambda} \right), \lambda = \frac{1 + \sqrt{1 + \alpha^2}}{2}, \alpha = \frac{b}{d}$$

Where the variables have their usual meanings.

2. (a) Elaborate on (with diagrams) the uplift pressures in jump through and design of weir floor thickness. (8 1/3)

(b) A barrage is to be constructed on an alluvial river having a flood discharge of 8500 cumecs. The relevant data are as follows: (15)

Average river bed level = 200.0 m

HFL (before construction of barrage) = 205.3 m

Permissibility afflux = 1.0 m

Lacey silt factor = 0.8

Determine (i) the crest level of undersluices and barrage bays (ii) the waterway to pass the flood discharge (iii) downstream floor level for undersluices portion considering a retrogression of 0.5 m and 20% discharge concentration.

3. (a) State the salient points of difference between: (6)

(i) aqueduct and syphon aqueduct (ii) silt excluder and silt extractor.

(b) A syphon aqueduct is to be designed for the following situation: (17 1/3)

**WRE 411**

**Contd ... Q. No. 3(b)**

	<u>Canal</u>	<u>Stream</u>
Discharge, m <sup>3</sup> /s	30.0	500.0
Bed level, m	200.0	198.0
Canal FSL, m	202.0	---
Bed width, m	25.0	----
Canal side slope (H : V)	1.5 : 1	
Stream HFL, m	---	200.5

Design (i) drainage waterway, (ii) canal waterway and (iii) transitions. Also calculate the head loss through the syphon barrels assuming  $f_2 = 0.0033$  for the materials of the surface of barrel.

4. (a) Write short notes with sketches on (3×5=15)
- (i) critical exit gradient
  - (ii) protection works for weirs
  - (iii) uplift on bottom floor of a syphon aqueduct
- (b) The head regulator of a canal has 3 openings each 4 m wide. The water is flowing between the upper and lower gates. The vertical opening of the gate is 1.0 m. The head on the regulator is 0.5 m. If the upstream water level rises by 0.2 m, find how much the upper gates must be lowered to maintain the canal discharge unchanged. (8 1/3)

**SECTION – B**

There are **FOUR** questions in this section. Answer any **THREE**.

5. (a) What factors govern the selection of a suitable site for construction of a dam? (6)
- (b) Show with neat sketches the various storage zones of a dam reservoir. Define the following with respect to the diagram. (6 1/3)
- (i) Maximum Conservation level (ii) Maximum Pool level (iii) Valley storage
- (c) A contour survey of a reservoir site gives the area of 8 ha, 24 ha and 45 ha at the contour values of 46 m, 62 m and 75 m respectively. The capacity of reservoir upto 46 m elevation is found to be 34 ha-m. Determine the reservoir capacity at the elevation of 85 m. (11)
6. (a) State the prominent features of a chute spillway. (4 1/3)
- (b) What are the two fundamental processes for energy dissipation below overflow spillway? How does energy dissipation principle work, when the tail water curve lies below the  $y_2$  Curve for all discharges? (7)

**WRE 411**

**Contd ... Q. No. 6**

- (c) Write short notes on (i) flash board (ii) drum gate. (6)
- (d) With relevant figures show how silt pressure and uplift pressure on a gravity dam can be estimated? (6)
  
- 7. (a) Derive discharge formula over an overflow spillway. (4 1/3)
- (b) For Ogee Spillway, the coefficient of discharge depends on various factors. Discuss with appropriate sketches. (8)
- (c) An Ogee Spillway with vertical upstream face has the following design parameter values: (11)
  - Design discharge = 6200 cumec
  - Crest Length = 150 m
  - Normal Reservoir level = 735 m
  - Average River bed level = 650 m

The spillway consists of 7 span having a clear width of 10 m each. Thickness of each pier may be taken as 2.5 m. Determine the u/s profile of the Spillway crest. Assume any reasonable value for data not given.
  
- 8. (a) "A tension crack by itself does not fail the structure, but it leads to the failure of the structure by producing excessive compressive stress" – justify this statement with proper engineering explanation. (5 1/3)
- (b) What is the function of a drainage gallery in a gravity dam? How shear strength at the base of the gravity dam can be increased? (2+2)
- (c) Find out the major principal stress and the intensity of shear stress at the toe of a given dam section (Figure: 1). Use unit weight as  $23.5 \text{ kN/m}^3$ . Also assume the allowable stress of concrete to be  $2500 \text{ kN/m}^3$ . (14)

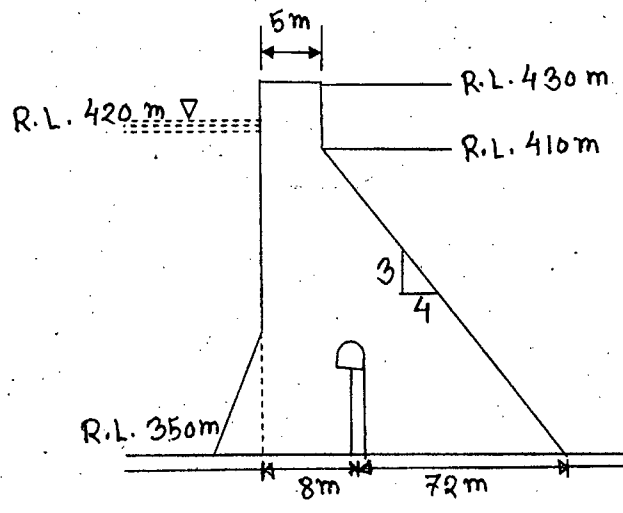
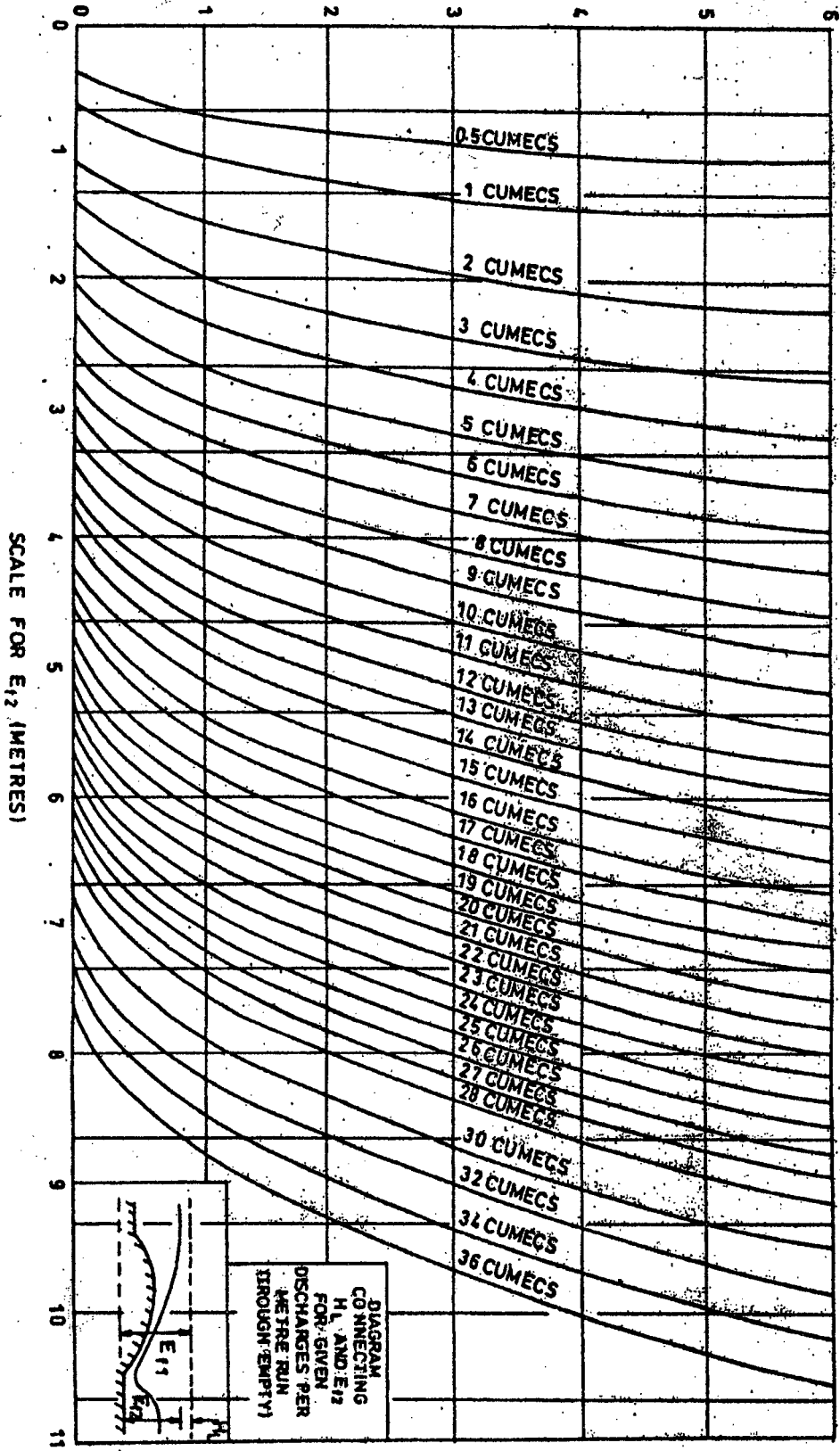

Figure: 1

SCALE FOR  $H_L$  (METRES)



For Q.No. 2(b)



Extra

L-4/T-2/WRE

Date : 10/05/2014

BANGLADESH UNIVERSITY OF ENGINEERING AND TECHNOLOGY, DHAKA

L-4/T-2 B. Sc. Engineering Examinations 2011-2012

Sub : **WRE 431** (Climatology)

Full Marks : 140

Time : 3 Hours

The figures in the margin indicate full marks.

USE SEPARATE SCRIPTS FOR EACH SECTION

**SECTION - A**

There are **FOUR** questions in this section. Answer any **THREE**.

1. (a) Briefly explain the effects of acid rain to lake ecosystem. (3 1/3)  
(b) Briefly explain the role of sunlight in Ozone depletion. (3)  
(c) Define Arctic Ozone hole. (3)  
(d) Explain why Ozone depletion in Antarctic Vortex ceases later in the Spring (i.e., Mid December). (3)  
(e) What happens if excessive amount of CO<sub>2</sub> is dissolved in the oceans? (3)  
(f) Explain how CFC is related to Ozone depletion. (3)  
(g) Explain how La Nina condition improves fishing in the Pacific Ocean near Peru. (3)  
(h) Name two sinks of stratospheric Chlorine. (2)
  
2. (a) Briefly explain the Southwest monsoon. (3 1/3)  
(b) Compare the potential global warming between CFC and CO<sub>2</sub>. (3)  
(c) Explain in brief the primary cause for the rise in sea level due to global warming. (3)  
(d) What happens to cyclones and hurricanes due to global warming and why? (3)  
(e) What happens to the Trade Wind during El Nino and La Nina episodes? (3)  
(f) Name three anthropogenic sources of Methane. (3)  
(g) Define Peru current and oceanic upwelling. (3)  
(h) Define ENSO. (2)
  
3. (a) Differentiate between Arid subtropical hot deserts and Arid mid latitude cool deserts. (3 1/3)  
(b) Define ITCZ. (3)  
(c) Differentiate between Thermosphere and Exosphere. (3)  
(d) Explain why temperature increases with altitude in the Thermosphere. (3)  
(e) Mention three distinguishing characteristics of tropical rain forest climate. (3)  
(f) Differentiate between Tundra and Icecap climates. (3)  
(g) Briefly explain the 1991 cyclone of Bangladesh. (3)  
(h) Mention two locations for Mediterranean climate. (2)

Contd ..... P/2

**WRE 431**

4. (a) '1987 flood was mainly triggered by human interference' – explain. (3 1/3)  
(b) Briefly explain any two of the human-induced causes of flood in Bangladesh. (3)  
(c) Explain the 'damming effect' that was associated with 2004 flood in Bangladesh. (3)  
(d) Explain how the El Nino is related to the flood in Bangladesh. (3)  
(e) Define atmospheric inversion. (3)  
(f) Differentiate between types I and II Polar stratospheric clouds. (3)  
(g) 'All rainfall is slightly acidic' – explain. (3)  
(h) Define Continental climate. (2)

**SECTION – B**

There are **FOUR** questions in this section. Answer any **THREE**.

Assume reasonable values if necessary.

5. (a) What is climate? Write three fundamental ways with examples that change the radiation balance of the earth. (2+3)  
(b) Draw the vertical thermal structure of the atmosphere showing the main zones of the atmosphere. What causes the temperature to rise or fall with height in each of these zones? (2+6)  
(c) How do oceans influence climate? Write down the hypsometric equation and define the terms. (4+2 1/3)  
(d) Calculate the thickness of the atmospheric layer between the 1050 hPa and 450 hPa pressure surfaces, (a) at a point in the tropics where the mean virtual temperature of the layer is 20°C, and (b) at a point in the polar regions where the mean virtual temperature is – 30°C. (4)
6. (a) What is cryosphere? Describe its influence on the climate system. (1+4)  
(b) Write short notes on Stefan-Boltzmann law for blackbody emission and Wien's law. (3)  
(c) Derive the expression of emission temperature of the earth. Determine solar flux density, solar constant, emission temperature of the earth and emission temperature of the sun from the following dataset: (4+7 1/3)  
Solar luminosity =  $3.9 \times 10^{26}$  W  
Radius of the sun =  $6.96 \times 10^8$  m  
Mean distance of earth from the sun =  $1.5 \times 10^{11}$  m  
Stefan-Boltzmann constant =  $5.67 \times 10^{-8}$  W m<sup>-2</sup> K<sup>-4</sup>  
Planetary albedo = 0.3  
(d) Write down the difference between (i) climate variable and climate forcing; (ii) statistical downscaling and dynamic downscaling. (2+2)

**WRE 431**

7. (a) What are the main programs in mesoscale model MM5? Briefly describe the purpose of each of these programs. (2+6)
- (b) What is GCM? Write 3 uses of GCM. (1+3)
- (c) Write short note on the monsoon precipitation of Bangladesh. (4)
- (d) Find the wind speeds at 2 m height for the following two cases when wind speed at 10 m above the soil surface is 3 m/s: (2+2)
- (i) The field is covered with vegetation of 2.12 m height.
- (ii) No information about vegetation height is available.
- (e) Briefly describe how land use change influence climate. (3 1/3)
8. (a) Find the vapor pressure deficit from the following data (3)
- Maximum temperature of the day = 35°C;
- Minimum temperature of the day = 11°C;
- Temperature at 8 am = 12.5°C.
- (b) Briefly describe 3 natural forcing of climate change? (4)
- (c) Describe how anthropogenic aerosols and atmospheric sulfur contribute to climate change. (4)
- (d) Determine solar radiation and net radiation from the following dataset obtained in a semi-humid area: (8)
- Temperature = 32 deg C, extraterrestrial radiation,  $R_a = 35 \text{ MJ/m}^2/\text{day}$ , Albedo = 0.2, Stefan-Boltzmann constant =  $4.903 \times 10^{-9} \text{ MJ K}^{-4}/\text{m}^2/\text{day}$ , actual duration of sunshine = 8.5 hours, maximum possible duration of sunshine = 11.5 hour, fraction of  $R_a$  reaching on the earth on overcast days = 0.2, fraction of  $R_a$  reaching on the earth on clear days = 0.75.
- (e) How can you estimate missing radiation data and humidity data? (4 1/3)
-