

Lafond  
21.09.2013

L-2/T-2/NAME

Date : 21/09/2013

BANGLADESH UNIVERSITY OF ENGINEERING AND TECHNOLOGY, DHAKA

L-2/T-2 B. Sc. Engineering Examinations 2011-2012

Sub : **NAME 223** (Marine Hydrodynamics)

Full Marks : 210

Time : 3 Hours

The figures in the margin indicate full marks.

Assume reasonable value of any missing data.

Symbols have their usual meaning.

USE SEPARATE SCRIPTS FOR EACH SECTION

**SECTION - A**

There are **FOUR** questions in this section. Answer any **THREE**.

1. (a) Define with neat sketches streamlines, streaklines and path lines. (12)  
(b) Describe characteristics of streamlines. (11)  
(c) Show that in a two-dimensional incompressible steady flow field the equation of continuity is satisfied with the velocity components given by – (12)  
$$u = \frac{K(x^2 - y^2)}{(x^2 + y^2)^2}, \quad v = \frac{2Kxy}{(x^2 + y^2)^2}$$
where K is an arbitrary constant.
2. (a) Derive Euler's equations of motion for a non-viscous fluid. (18)  
(b) How can you modify Euler's equations incorporating the effect of viscosity? (17)
3. (a) Describe boundary layer theory. (12)  
(b) Distinguish between smooth-wall turbulent flow and rough-wall turbulent flow. (10)  
(c) Water at 70 °F flows past a smooth plane surface. Near a point on the surface several feet from the leading edge the velocities at  $\frac{1}{4}$  inch and  $\frac{1}{2}$  inch from that wall are 6.2 and 6.7 ft/sec respectively. Assuming that boundary layer is turbulent, determine  $y'$ ,  $v_*$  and  $\delta'$  and estimate the velocity one inch from the wall. (13)
4. (a) State and prove Blasius's theorem. (18)  
(b) How can you determine the force developed for the flow around a cylinder of any cross-section with circulation? (17)

Contd ..... P/2

NAME 223

SECTION - B

There are **FOUR** questions in this section. Answer any **THREE**.

5. (a) Explain what you mean by a doublet. Derive the expressions for  $\phi$  and  $\psi$  for the doublet. Show that the magnitude of the velocity is constant on any circle centred on the doublet. (20)
- (b) Draw and discuss the flow pattern obtained from 'vortex pair'. (15)
6. (a) Explain what you mean by 'irrotational vortex'. (5)
- (b) Derive an expression for the strength of the irrotational vortex. (15)
- (c) Explain what you mean by 'circulation'. Show that the circulation around all streamlines of an irrotational vortex is constant and equal to the strength of the vortex. (15)
7. (a) Explain what you mean by 'analytic functions' and 'singular points'. Give some examples. (20)
- (b) Derive the Cauchy-Riemann equations. Discuss the significance of these equations with particular reference to irrotational flow. (15)
8. (a) Draw and describe the flow pattern for the transformation  $\omega = 2z^2$ . Determine the magnitude and direction of the velocity at the point (3, 2). (15)
- (b) Explain what you mean by (20)
- (i) The complex operator
- (ii) The complex velocity
-

L-2/T-2/NAME

Date : 28/09/2013

BANGLADESH UNIVERSITY OF ENGINEERING AND TECHNOLOGY, DHAKA

L-2/T-2 B. Sc. Engineering Examinations 2011-2012

Sub : **EEE 261** (Electrical and Electronic Technology for Marine Engineers)

Full Marks: 210

Time : 3 Hours

USE SEPARATE SCRIPTS FOR EACH SECTION

The figures in the margin indicate full marks.

**SECTION - A**

There are **FOUR** questions in this section. Answer any **THREE**.

1. (a) Assuming that the diodes are ideal, find the output voltage  $v_o$  for the circuit given in Fig. 1(a). (15)

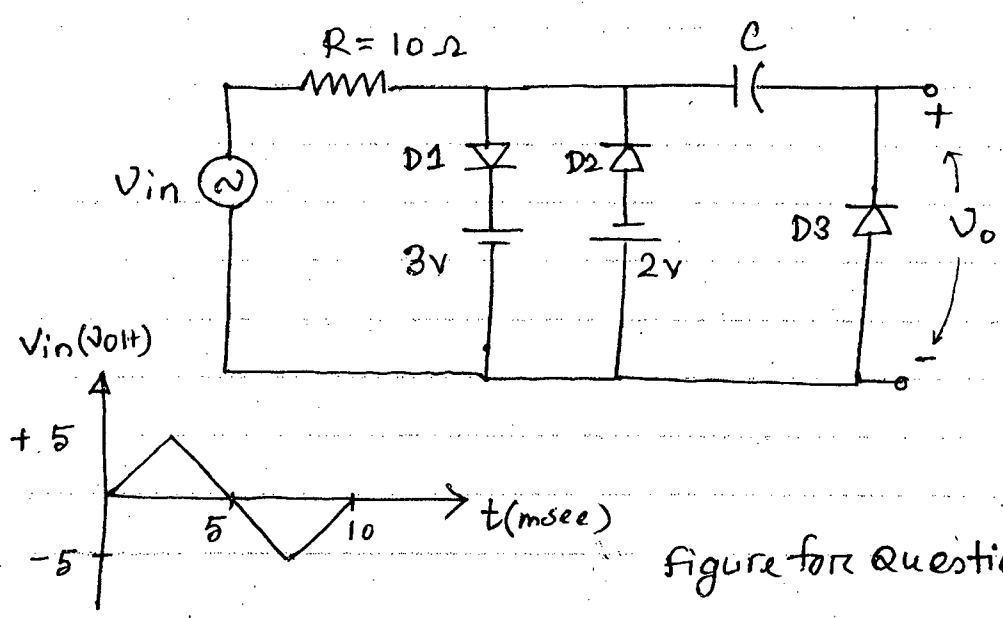

figure for question 1(a)

- (b) For the input given as  $V_{in}$ , calculate and draw the output voltage  $V_{out}$  for the circuit of Fig. 1(b). (20)

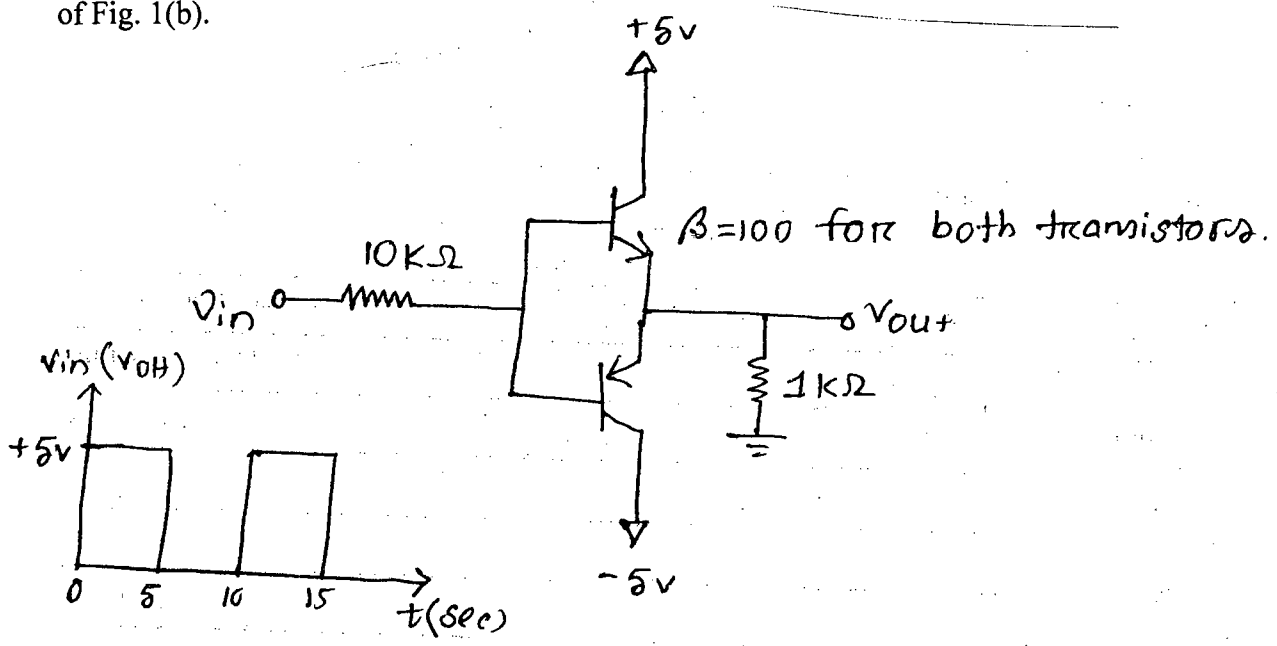

Fig. for Q. no. 1(b)

**EEE 261**

2. (a) Write down the short notes on (15)

- (i) LORAN
- (ii) Decca chain.

Each note should include definition, frequency range, working principle, Accuracy and application.

(b) Minimum Signal to noise ratio for a radar is  $\beta$ . Assuming all the necessary constants find the maximum range of that radar. (20)

3. (a) Analyze the circuit shown in Fig. 3(a) to determine the voltages at node A & B and the drain current  $I_D$ . Let  $V_{TH} = 1\text{ v}$  and  $k'_n \left(\frac{W}{L}\right) = 1\text{ mA/v}^2$ . Neglect the channel length modulation effect (i.e. Assume  $\lambda = 0$ ). (20)

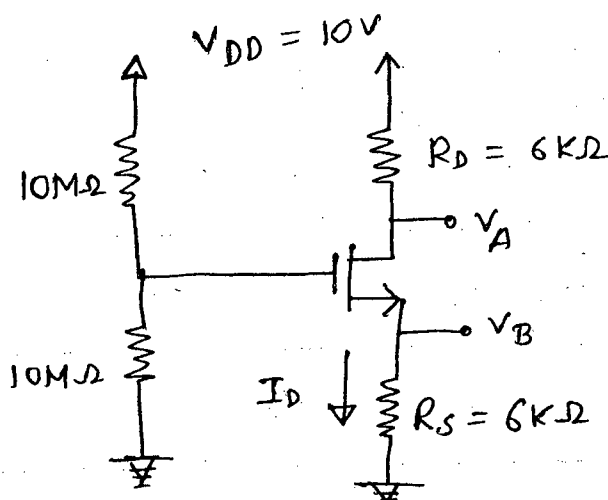

Figure for question 3(a)

(b) Draw a Full-Bridge Inverter circuit and explain its operation. Also mention some applications of inverter. (15)

4. (a) Draw the circuit and explain the operation of a controlled Full-Wave rectifier. (15)

Also show that the output DC voltage for this rectifier is given by the following equation

$$V_{DC} = \frac{V_P}{2\pi} (1 + \cos \theta)$$

where,  $V_P$  = Amplitude of input Sine wave

$\theta$  = SCR firing angle.

**EEE 261**

**Contd... Q. No. 4**

(b) For the input given as  $v_{in}$  find the voltage  $v_{out}$  for the circuit given in Fig. 4(b). (20)

Given  $v_{TH} = 1\text{ V}$

$w/L = 32, k'_0 = 100\mu\text{A}/\text{V}^2$

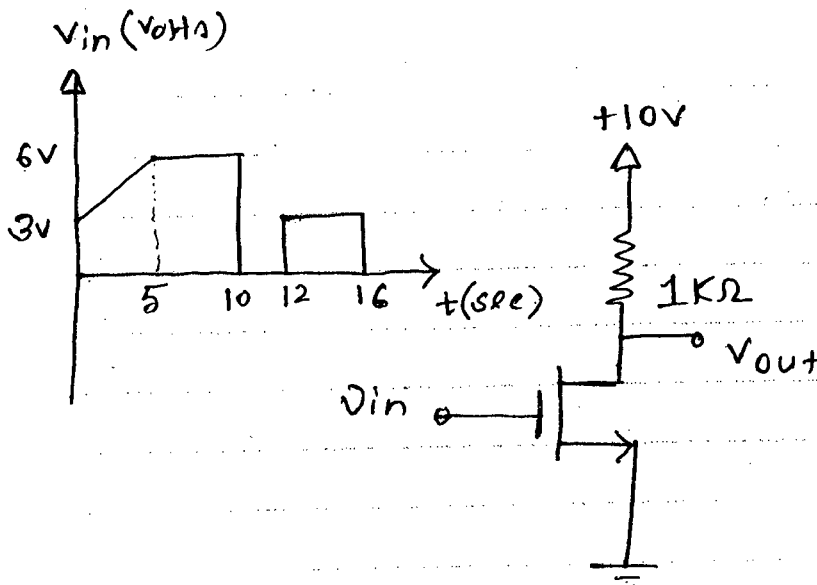

Fig. for Q. no. 4 (b)

**SECTION - B**

There are **FOUR** questions in this section. Answer any **THREE**.

All the symbols have their usual meanings.

- 5. (a) Derive the power and torque equation of synchronous generator. (10)
- (b) Draw the delta connected equivalent circuit diagram of a synchronous generator. (10)
- (c) A 200 kVA, 480 V, 50 Hz Y-connected synchronous generator with a rated field current 6 A was tested and following data were taken. (15)
  - (i)  $V_{T,OC}$  at the rated  $I_F$  was measured to be 540 V.
  - (ii)  $I_{L,SC}$  at the rated  $I_F$  was found to be 350 A.
  - (iii) When a dc voltage of 20 V was applied to two of the terminals, a current of 50 A was measured.

Obtain the equivalent circuit diagram of the synchronous motor.

- 6. (a) What is "synchronous motor V-curve"? On the basis of V-curves, discuss the effect of field current changes on a synchronous motor. (10)
- (b) Explain how a synchronous motor can be used as a capacitor for power factor correction. Also draw the V-curve and phasor diagram of a synchronous condenser. (15)
- (c) Draw the phasor diagram of a nonsalient pole synchronous generator with capacitive load. (10)

**EEE 261**

7. (a) Explain the effect of load changes on a synchronous motor using neat phasor diagrams. (15)

(b) A three phase 208 V, 45 kVA, 0.8 pf leading,  $\Delta$ -connected 60 Hz synchronous motor has a synchronous reactance of 2.5  $\Omega$  and a negligible armature resistance. Its friction and windage losses are 1.5 kW, and its core losses are 1.0 kW. (20)

Initially, the shaft is supplying a 15 hp load, and the motor's power factor is 0.80 leading.

If the shaft load is increased to 30 hp, find the value of new armature current and power factor.

8. (a) Obtain the Steinmetz Equivalent circuit of a three phase induction motor. (10)

(b) Show that the developed torque in a three phase induction motor is given by the following equation (10)

$$T_D = \frac{21.12 R_r [E_{BR}]^2}{sn_s \left\{ (R_r / s)^2 + X_{BR}^2 \right\}}$$

(c) A three phase, 230 V, 60 Hz, 100 hp 6 pole induction motor is operated at rated conditions has an efficiency of 91.0% and draws a line current of 248 A. The core loss, stator copper loss and rotor conductor loss are 1.7 kW, 2.8 kW and 1.5 kW, respectively. Determine (i) power input (ii) total losses (iii) air-gap power (iv) shaft speed (v) power factor (vi) shaft torque. (15)

-----

*Amad*  
5.10.13

L-2/T-2/NAME

Date : 05/10/2013

BANGLADESH UNIVERSITY OF ENGINEERING AND TECHNOLOGY, DHAKA

L-2/T-2 B. Sc. Engineering Examinations 2011-2012

Sub : **HUM 211** (Sociology)

Full Marks: 140

Time : 3 Hours

USE SEPARATE SCRIPTS FOR EACH SECTION

The figures in the margin indicate full marks.

**SECTION – A**

There are **FOUR** questions in this section. Answer any **THREE**.

1. (a) What is Industrial Revolution? Describe the effects of Industrial Revolution on society. (13 1/3)
- (b) Describe the factors affecting globalization process. (10)
2. (a) Critically discuss the 'Robert Malthus' Theory' and the 'Demographic Transition Theory' of population. (10)
- (b) What is demography? Illustrate the elements of demography. (13 1/3)
3. (a) Critically discuss the functionalist view of Urbanization. (10)
- (b) What are the key features of pre-urban, urban and post-urban cities? (13 1/3)
4. Write short notes on any of three of the following: (23 1/3)
  - (a) Population pyramid
  - (b) Types of migration
  - (c) Environmental pollution
  - (d) Forces of migration.

**SECTION – B**

There are **FOUR** questions in this section. Answer any **THREE**.

5. (a) What do you understand by social values? How do sociologists maintain a value neutral position for studying human society? Explain your answer in the context of sociological imagination with suitable examples. (10)
- (b) Explain the distinct properties of functionalist theoretical perspective of sociology. (13 1/3)

Contd ..... P/2

**HUM 211**

6. (a) What is social mobility? Explain different types of social mobility focusing ascribed status and achieved status. **(10)**
- (b) What is meant by social stratification? Discuss caste system of social Stratification. **(13 1/3)**
7. (a) How does socialization shape human behaviour? Write your answer highlighting the agents of socialization. **(10)**
- (b) Discuss C. H. Cooley's looking-glass self theory. **(13 1/3)**
8. Write short notes on any three of the following: **(23 1/3)**
- (a) Sociobiology
  - (b) Dominant ideology
  - (c) Ethnocentrism
  - (d) Cultural transmission theory of deviance.
-



L-2/T-2/NAME

Date : 22/07/2013

BANGLADESH UNIVERSITY OF ENGINEERING AND TECHNOLOGY, DHAKA

L-2/T-2 B. Sc. Engineering Examinations 2011-2012

Sub : **MATH 283** (Partial Differential Equation, Matrices and Statistics)

Full Marks: 210

Time : 3 Hours

USE SEPARATE SCRIPTS FOR EACH SECTION

The figures in the margin indicate full marks.

Symbols used have their usual meaning.

**SECTION – A**

There are **FOUR** questions in this section. Answer any **THREE**.

1. (a) For a square matrix A, show that  $A + A^\circ$  is Hermitian and  $A - A^\circ$  is skew-Hermitian. (10)

- (b) Find the inverse from the adjoint of the following: (12)

$$\begin{bmatrix} 2 & 1 & 5 \\ 0 & 2 & 1 \\ 0 & 0 & 2 \end{bmatrix}$$

- (c) Find the canonical matrix row equivalent to the following matrix: (13)

$$\begin{bmatrix} 1 & 2 & 3 & 4 \\ 2 & 7 & 3 & 5 \\ 3 & 8 & 1 & -2 \end{bmatrix}$$

2. (a) Reduce  $A = \begin{bmatrix} 1 & -2 & 1 & 3 \\ 4 & -1 & 5 & 8 \\ 2 & 3 & 3 & 2 \end{bmatrix}$  (17)

to the normal form B and compute the matrices P and Q such that  $PAQ = B$ , where A and B are equivalent matrices.

- (b) Solve the following system of equations by using matrix. (18)

$$\begin{aligned} x_1 - 2x_2 + 3x_3 - 4x_4 &= 5 \\ x_1 - 3x_2 + 7x_3 - 6x_4 &= 7 \\ 2x_1 - 5x_2 + 10x_3 - 11x_4 &= 12 \end{aligned}$$

3. (a) Find the differential equation by eliminating  $\phi$  from  $\phi(x + y + z, x^2 + y^2 - z^2) = 0$ . (12)

- (b) Solve:  $(y^2 + z^2 - x^2)p - 2xyq + 2xz = 0$ . (11)

- (c) Find the integral surface of the linear partial differential equation  $x(y^2 + z)p - y(x^2 + z)q = (x^2 - y^2)z$ , which contains the line  $x + y = 0, z = 1$ . (12)

= 2 =

**MATH 283**

4. Solve the following:

(a)  $(p^2 + q^2)y = qz$  by Charpit's method. (12)

(b)  $\frac{\partial^3 z}{\partial x^3} - \frac{\partial^3 z}{\partial y^3} = x^3 y^3$  (11)

(c)  $x^2 \frac{\partial^2 z}{\partial x^2} + 2xy \frac{\partial^2 z}{\partial x \partial y} - x \frac{\partial z}{\partial x} = \frac{x^3}{y^2}$ . (12)

**SECTION – B**

There are **FOUR** questions in this section. Answer any **THREE**.

5. (a) Lives of two models of refrigerators in a survey are as follows: (18)

Life (Number of years)	Number of refrigerators	
	Model A	Model B
0–2	5	2
2–4	16	7
4–6	13	12
6–8	7	19
8–10	5	9
10–12	4	1

which model has greater uniformity?

(b) A survey was conducted by a manufacturing company to enquire the maximum price at which persons would be willing to buy their product. The following table gives the stated price in taka by persons. (17)

Price (in Tk.)	80–90	90–100	100–110	110–120	120–130
Number of persons	11	29	18	27	15

Calculate Karl Pearsons' coefficient of skewness and interpret the result.

6. (a) Calculate the first four moments about the origin from the following data. (18)

x:	0	1	2	3	4	5	6	7	8
f:	5	10	15	20	25	20	15	10	5

Also calculate the values of  $\beta_1$  and  $\beta_2$  and comment on the nature of the distribution.

(b) The following table gives the relative values of two variables. (17)

X:	42	44	58	55	89	98	66
Y:	56	49	53	58	65	76	51

Find the regression lines of Y on X and X on Y.

**MATH 283**

7. (a) Define binomial and Poisson distribution. Let  $x$  be a binomial random variable with probability distribution  $b(x; n, p)$ . When  $n \rightarrow \infty$ ,  $p \rightarrow 0$  and  $\lambda = np$  remains constant, show that  $b(x; n, p) \rightarrow P(x; \lambda)$ . (12)

(b) In an urn there are 1 black and 2 white balls; in another there are 2 black and 1 white balls. A ball is drawn from the first and put into the second and then a ball is drawn from the second urn. What is the probability that the ball drawn from the second urn is white? (12)

(c) The Edison Electric Institute has published figures on the annual number of kilowatt-hours expended by various home appliances. It is claimed that a vacuum cleaner expends an average of 46 kilowatt-hours per year. If a random sample of 12 homes included in a planned study indicates that a vacuum cleaner expends an average of 42 kilowatt-hours per year with a standard deviation of 11.9 kilowatt-hours. Does this suggest at the 0.05 level of significance that the vacuum cleaners expend, on the average, less than 46 kilowatt-hours annually? The critical value is 1:796. (11)

8. (a) Reduce the quadratic form  $x_1^2 + 5x_2^2 + 8x_2x_3 + 6x_3x_1 + 4x_1x_2$  to the canonical form. Also write down the corresponding equations of transformation. (20)

(b) Verify Cayley-Hamilton theorem for the matrix  $A = \begin{bmatrix} 1 & 2 & 1 \\ 3 & 4 & 0 \\ 1 & 0 & 1 \end{bmatrix}$  and hence find its inverse. (15)

-----