

SECTION - A

There are **FOUR** questions in this section. Answer any **THREE**.

1. (a) State any five contemporary models of motivation. Explain Maslow's need theory. (15)
- (b) A pharmacist has been monitoring sales of a certain over the counter pain reliever. (20)
- Daily sales during the last 15 days were

Day:	1	2	3	4	5	6	7	8	9	10	11	12	13	14	15
Number sold:	36	38	42	44	48	49	50	49	52	48	52	55	54	56	57

- (i) Which method would you suggest using to predict future sales—a linear trend equation or trend adjusted exponential smoothing? Why?
- (ii) Assume that the data refer to demand rather than sales. Using trend adjusted smoothing with an initial forecast of 50 for week 8, an initial trend estimate of 2 and $\alpha = \beta = 0.3$, develop forecasts for days 9 through 16. What is the MSE for the eight forecasts for which there are actual data?
2. (a) Teri Hall has recently opened Sheer Elegance, Inc., a store specializing in fashionable stockings. Ms. Hall has just completed a course in managerial accounting and she believes that she can apply certain aspects of the course to her business. She is particularly interested in adopting the cost-volume profit (CVP) approach for decision making. Thus she has prepared the following analysis: (25)

Sales price per pair of stockings	\$ 2.00
Variable expense per pair of stockings	0.80
Contribution margin per pair of stockings	<u>\$ 1.20</u>
Fixed expenses per year	
Building rental	\$ 12,000
Equipment depreciation	3,000
Selling	30,000
Administrative	15,000
Total fixed expense	<u>\$ 60,000</u>

IPE 493 (EEE)

Contd ... Q. No. 2(a)

Required:

- (i) How many pairs of stockings must be sold to break even? What does this represent in total dollar values?
- (ii) Prepare a CVP graph for the store from a zero level of activity upto 70,000 pairs of stockings sold each year. Indicate break even point on the graph.
- (iii) How many pairs of stocking must be sold to earn a \$ 90,000 target profit for the first year?
- (iv) Mr. Hall has now 1 full time and 1 part time sales person working in the store. It will cost her an additional \$ 8,000 per year to convert the part time position to a full time position. Mr. Hall believes that the change would bring in an additional \$ 20,000 in sales each year. Should she convert the position?
- (v) Refer to the original data. Actual operating results for the first year are as follows:

Sales	\$ 125,000
Less variable Expense	50,000
Contribution Margin	75,000
Less fixed expense	60,000
Net operating income	\$ 15,000

- (a) What is the store's degree of operating of leverage? (b) Mr. Hall is confident that with some effort she can increase sales by 20% next year. What would be the expected percentage increase in net operating income?
- (b) Briefly define chain of command and span of control. Discuss the differences between wide span of control and narrow span of control. (10)

3. (a) What is contingency approach to leadership? According to Hersey and Blanchard's leadership model what are the 4 phases through which the relationship between managers and followers moves? State with figure. Fiedler measured leadership style on a scale – what was that? Briefly explain. (15)

(b) A small manufacturing firm uses roughly 3400 pounds of chemical dye a year. Currently the firm purchases 300 pounds per order and pays \$ 3 per pound. The supplier has just announced that orders of 1000 pounds or more will be filled at a price of \$ 2 per pound. The manufacturing firm incurs a cost of \$ 100 each time it submits an order and assigns an annual holding cost of \$ 17% of the purchase price per pound. (i) Determine the order size that will minimum the total cost. (ii) If the supplier offered the discount at 1500 pounds, what order size would minimize total cost? (15)

(c) State the basic objectives of 7 tools of TQM along with their interpretation. (5)

IPE 493 (EEE)

4. (a) Differentiate between efficiency and effectiveness. Briefly explain the four basic functions of managers. (15)

(b) The following tasks must be performed on an assembly line in the sequence and times specified: (20)

Task	Task Time (seconds)	Task that must precede
A	50	---
B	40	---
C	20	A
D	45	C
E	20	C
F	25	D
G	10	E
H	35	B, F, G

(i) Draw the schematic diagram.

(ii) What is the theoretical minimum number of stations required to meet a forecasted demand of 400 units per 8 hour day?

(iii) Find the balance that minimizes the number of workstations, subject to cycle time and precedence constraints and also calculate the efficiency of the line.

SECTION – B

There are **FOUR** questions in this section. Answer any **THREE**.

5. (a) Three public investment alternatives are available: A₁, A₂ and A₃. Their respective total benefits, costs and initial costs are given in present worth as follows: (15)

Present worth	Proposals		
	A ₁	A ₂	A ₃
I	\$ 100	\$ 300	\$ 200
B	\$ 400	\$ 700	\$ 500
C'	\$ 100	\$ 200	\$ 150

Three alternatives have the same service life. Assuming no do-nothing alternative, which project would you select, based on the benefit-cost ratio on incremental investment?

(b) What do you mean by 'PLC' in marketing? Mention its different stages with appropriate examples. (10)

(c) What are the scopes/entities in which marketing people are involved? (10)

IPE 493 (EEE)

6. (a) You are presented with the summary of projected costs and annual receipts for new product line. Calculate the IRR for this investment opportunity. **(20)**

End of year	Net cash flow, \$
0	- 450,000
1	- 42,500
2	+ 92,800
3	+ 386,000
4	+ 614,600
5	- 202,200

- (b) Selling of Djuice sim (a product of Grameen Phone) follows bell shaped PLC curve. Do you agree? Justify your answer. **(7)**
- (c) Mention different types of buying behavior based on the degree of buyer involvement with appropriate examples. **(8)**
7. (a) What is the amount of 10 equal annual deposits that can provide five annual withdrawals, where a first withdrawal of \$ 3,000 is made at the end of year 11 and subsequent withdrawals increase at the rate of 6% per year over the previous year's if the interest rate is 6% compounded annually? **(18)**
- (b) What are the competitive strategies under which market follower conduct their marketing activities? Give appropriate examples. **(10)**
- (c) How societal marketing concept is different from marketing concept? **(7)**
8. (a) Leading role of a manager decreases where as planning and organizing role increases in an ascending order of the management levels – why? Explain with figure. **(10)**
- (b)"The steeper the total sales curve in a CVP graph the more profit or net operating income occurs" – Explain. **(5)**
- (c) Briefly explain Joseph Jusan's "Zone of indifference". **(5)**
- (d) According to classical approach what are the distinctive characteristics that an organization should possess to be the most efficient and effective one? Briefly explain. **(10)**
- (e) If exponential smoothing technique is used when data shows a trend pattern what will happen? Which forecasting technique is appropriate for this situation? **(5)**
-

S. Arabin

L-3/T-2/EEE

Date : 17/12/2012

BANGLADESH UNIVERSITY OF ENGINEERING AND TECHNOLOGY, DHAKA

L-3/T-2 B. Sc. Engineering Examinations 2010-2011

Sub : **EEE 331** (Random Signal and Processes).

Full Marks: 210

Time : 3 Hours

USE SEPARATE SCRIPTS FOR EACH SECTION

The figures in the margin indicate full marks.

SECTION - A

There are **FOUR** questions in this Section. Answer any **THREE**.

Symbols have their usual meanings.

Table of Fourier Transform is supplied.

1. (a) A certain communication system transmits the signal $S(t)$ show in Fig. Q. 1(a). At the receiver, the signal received is $R(t)$, where $R(t) = S(t) + N(t)$; $N(t)$ being an additive white Gaussian noise with zero mean and variance σ_n^2 . Determine the impulse response of the matched filter that provides maximum SNR at $t = 3t_0$. Using the impulse response, find the output of the filter. Sketch the output and describe how the presence of the signal $S(t)$ can be detected from the output of the filter. (15)

- (b) A random process $X(t)$ has the following autocorrelation function: (20)

$$R_{XX}(\tau) = 36 + \frac{4}{1 + \tau^2}$$

Determine (i) $E(X)$ and (ii) σ_X^2 . Verify whether the process is mean-ergodic in the mean-square sense.

2. (a) A random process $X(t)$ is given by (15)

$$X(t) = A \cos(t) + (B+1) \sin(t); \quad -\infty < t < \infty$$

where A and B are independent random variables with $E(A) = E(B) = 0$ and $E(A^2) = E(B^2) = 1$. Find if $X(t)$ is wide-sense stationary. Is it stationary in strict-sense?

- (b) For the hignpass filter shown in Fig. Q. 2(b), the input signal $X(t)$ is given by (20)

white $X(t) = A \sin(\omega_c t + \theta) + N(t)$

where $N(t)$ is additive ~~white~~ Gaussian noise and θ is an uniformly distributed random variable over $[0, 2\pi]$. Assuming zero initial conditions determine (i) the mean and variance of the output $Y(t)$, (ii) the autocorrelation function of of $Y(t)$ and (iii) power spectral density of $Y(t)$.

Assume that ω_c is an arbitrary constant frequency, and the filter a linear time-invariant system.

EEE 331

3. (a) The power spectral density of a random process is shown in Fig. Q. 3(a). Verify whether the process has a derivative in the mean-square sense. (15)

- (b) A wide-sense stationary continuous-time process $X(t)$ has the following autocorrelation function: (20)

$$R_{X_c X_c}(\tau) = 2e^{-4|\tau|}$$

$X_c(t)$ is sampled with a sampling period of 10 seconds to produce the discrete-time sequence $X(n)$. Obtain the power spectral density of $X(n)$.

The sequence $X(n)$ is then provided as input to a linear time-invariant system with impulse response

$$h(n) = e^{-an}u(n)$$

Find the power spectral density of the output of the system.

4. (a) Two random variables X and Y have the joint probability density function (pdf) which is given by (15)

$$f_{XY}(x, y) = 4xy; \quad 0 < x < 1 \text{ and } 0 < y < 1.$$

Let the random variable u be defined as $U = X + Y$

Determine (i) $f_u(u)$ and (ii) $\phi_u(u)$.

- (b) Two random variables X and Y have variances $\sigma_x^2 = 16$ and $\sigma_y^2 = 36$. Given that

~~$P_{XY} = 0.5$~~ $P_{XY} = 0.50$

(20)

Determine (i) C_{XY} , (ii) if X and Y are orthogonal where $E(X) = -3$ and $E(Y) = 4$,

(iii) σ_z^2 where $Z = X + Y$ and (iv) σ_w^2 where $W = X - Y$.

SECTION - B

There are **FOUR** questions in this Section. Answer any **THREE**.

5. (a) Consider the communication channel shown in Fig. Q. 5(a). The x transition probabilities are as follows: (20)

$P_{0/0} = 0.8, P_{1/0} = 0.1, P_{E/0} = 0.1, P_{0/1} = 0.2, P_{1/1} = 0.7$ and $P_{E/1} = 0.1$. Here $P_{Y/X}$ means the probability that Y is received, given X is transmitted. If $P[X=0] = P[X=1] = 0.5$, find

- (i) $P[Y=0], P[Y=1]$ and $P[Y=E]$, (ii) If 0 is received, the probability that the transmitted bit is 0, (iii) If E is received, the probability that 1 is transmitted and (iv) If 1 is received, the probability that 1 is transmitted.

EEE 331

Contd Q. No. 5

(b) An audio amplifier contains six transistors. It is known that two of these transistors are defective. However, which two transistors are defective, is not known. Suppose you remove three transistors to inspect. Let X be the number of defective transistors found after inspection. Sketch the probability mass function (pmf) of X for $X = 0, 1, 2$ and 3 . (15)

6. (a) State and prove central limit theorem. What is the significance of this theorem? (20)

(b) A random variable X has the following pdf: (15)

$$f_x(x) = \begin{cases} \frac{1}{7}, & -3 < x < 4 \\ 0, & \text{otherwise} \end{cases}$$

Determine (i) $P\{|X - 1.5| \geq 2\}$ using Chebyshev inequality and (ii) $P\{X > 3.5\}$ using Markov inequality. Comment on the results.

7. (a) Let X and Y be independent Zero mean Gaussian random variables with $\sigma_x^2 = 4$ and $\sigma_y^2 = 9$. Find the pdf of Z where $Z = 2X - 3Y$ using the characteristic function of Z . (20)

(b) Two random variables X and Y have the joint pdf given by (15)

$$f_{x,y}(x,y) = \begin{cases} \frac{1}{\pi}, & x^2 + y^2 \leq 1 \\ 0, & \text{otherwise} \end{cases}$$

Find whether X and Y are uncorrelated and independent.

8. (a) Two random variables X and Y have the joint pdf given by (20)

$$f_{x,y}(x,y) = \frac{1}{2\pi\sqrt{3}} e^{-\frac{(x^2 + 2xy + 4y^2)}{6}}, \quad -\infty < x < \infty, -\infty < y < \infty$$

Determine

- (i) $f_x(x)$ and $f_y(y)$,
- (ii) $E(X), E(Y), \sigma_x^2$ and σ_y^2
- (iii) $f_{x/y}(x/y)$ and $f_{y/x}(y/x)$
- (iv) $Cov(X,Y)$ and ρ_{xy}

(b) A random variable has the following pdf (15)

$$f_x(x) = \begin{cases} K(1-x^4), & -1 \leq x \leq 1 \\ 0, & \text{otherwise} \end{cases}$$

EEE 331

Contd Q. No. 8(b)

Find

- (i) $F_X(x)$,
- (ii) Value of K,
- (iii) $P\left[X < \frac{1}{2}\right]$,
- (iv) $P\left[-\frac{1}{2} < x \leq \frac{1}{2}\right]$.

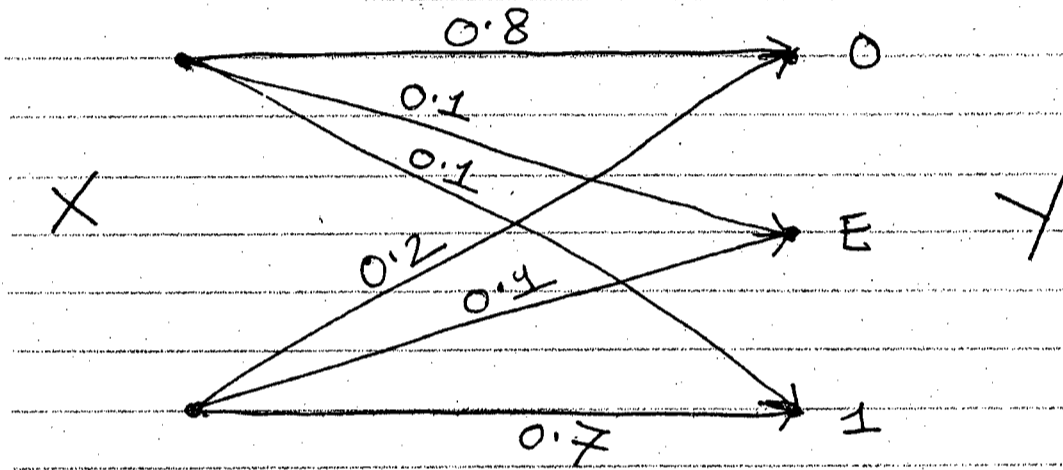

Fig. Q. 5(a)

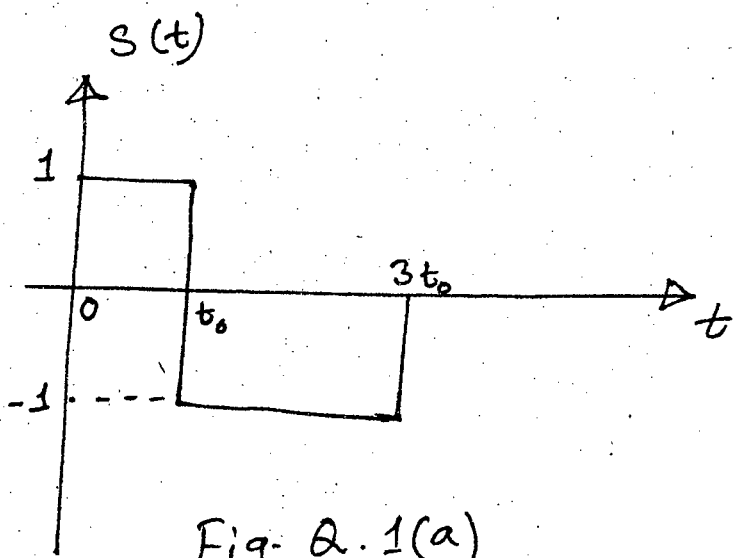

Fig. Q.1(a)

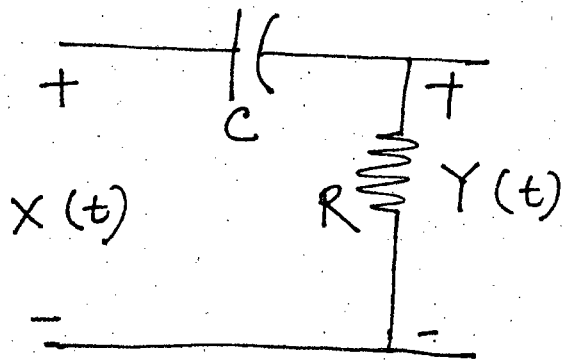

Fig. Q.2(b)

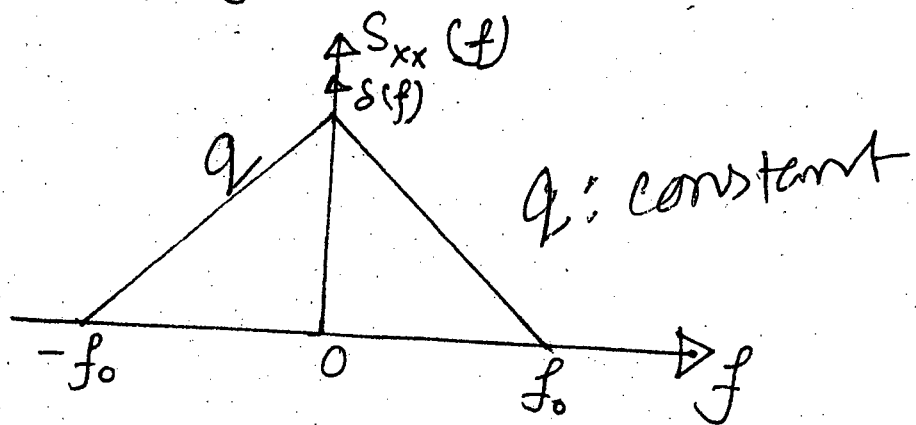

Fig. Q.3(a)

Table 8.1 Some Common Fourier Transform Pairs

$x(\tau)$	$X(\omega)$
$e^{-a \tau }, a > 0$	$\frac{2a}{a^2 + \omega^2}$
$e^{-a\tau}, a > 0, \tau \geq 0$	$\frac{1}{a + j\omega}$
$e^{b\tau}, b > 0, \tau < 0$	$\frac{1}{b - j\omega}$
$\tau e^{-a\tau}, a > 0, \tau \geq 0$	$\frac{1}{(a + j\omega)^2}$
1	$2\pi\delta(\omega)$
$\delta(\tau)$	1
$e^{j\omega_0\tau}$	$2\pi\delta(\omega - \omega_0)$
$\begin{cases} 1 & -T/2 < \tau < T/2 \\ 0 & \text{otherwise} \end{cases}$	$T \frac{\sin(\omega T/2)}{(\omega T/2)}$
$\begin{cases} 1 - \tau /T & \tau < T \\ 0 & \text{otherwise} \end{cases}$	$T \left[\frac{\sin(\omega T/2)}{(\omega T/2)} \right]^2$
$\cos(\omega_0\tau)$	$\pi\delta(\omega - \omega_0) + \pi\delta(\omega + \omega_0)$
$\sin(\omega_0\tau)$	$-j\pi[\delta(\omega - \omega_0) - \delta(\omega + \omega_0)]$
$e^{-a \tau } \cos(\omega_0\tau)$	$\frac{a}{a^2 + (\omega - \omega_0)^2} + \frac{a}{a^2 + (\omega + \omega_0)^2}$

page - 6

Fauzan Hossain
14/1/13

L-3/T-2/EEE

Date : 19/11/2012

BANGLADESH UNIVERSITY OF ENGINEERING AND TECHNOLOGY, DHAKA

L-3/T-2 B. Sc. Engineering Examinations 2010-2011

Sub : **EEE 309** (Communication Theory)

Full Marks: 210

Time : 3 Hours

USE SEPARATE SCRIPTS FOR EACH SECTION

The figures in the margin indicate full marks.

SECTION - A

There are **FOUR** questions in this Section. Answer any **THREE**.

1. (a) Discuss the limitations of a communication channel and their effects on the performance of a communication link. (10)
(b) Distinguish between baseband transmission and bandpass transmission. Draw the block diagram of a baseband transmission system and explain how the distortion occurs in such a system. Why are repeaters used in such a system? (15)
(c) Derive the Nyquist condition for distortionless transmission through a baseband transmission system and explain briefly. (10)

2. (a) What is meant by multiplexing? State the purpose of multiplexing. Briefly discuss the principles of FDM and TDM. Distinguish between asynchronous, plesiochronous and synchronous TDM. (10)
(b) With necessary schematic diagram, discuss the CCITT recommended FDM schemes for generation of FDM groups, Super groups and Master groups. (10)
(c) 16 T_1 (DS1) channels are time multiplexed with 8 E_1 channels and a data channel as shown in the following diagram. Bandwidth available for transmission over the channel is 100 MHz. Determine the allowable bit rate R_{b_3} of the data channel, R_{b_1} , R_{b_2} and output bit rate, R_o . Assume channel spectral efficiency of 1 bit/sec-Hz. (15)

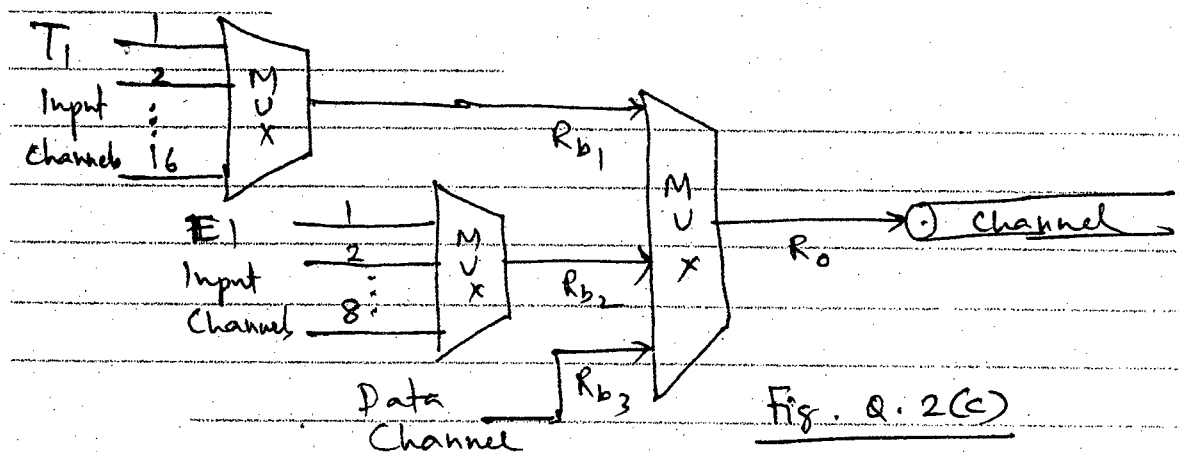

EEE 309

3. (a) Define amplitude modulation (AM) and the index of AM. Write an expression of the AM signal for a single sinusoid as the modulating signal and find the expression of the spectrum of the AM signal. (10)

(b) The modulating signal input to a square-law modulator is given by $p_m(t) = 10 \sin(2\pi \times 10^3 t) + 5 \cos(2\pi \times 10^4 t) + 3 \cos(4\pi \times 10^4 t)$. The carrier is a sinusoid with frequency 1 MHz and peak amplitude 24 Volt. The output of the square-law modulator is passed through a BPF to generate DSB signal. Draw the spectrum of the signal at the input and output of the BPF and determine: (15)

- (i) bandwidth of the BPF filter;
- (ii) the overall modulation index;
- (iii) power in the sidebands;
- (iv) total power in the DSB signal.

(c) What are meant by heterodyne and coherent detection? Draw the block diagram of a superheterodyne AM envelope detection receiver and show the waveforms at different output stages. (10)

4. (a) What is meant by angle modulation and what are its different forms? Write expressions for FM and PM signals and show how an FM signal can be generated using a PM modulator. (10)

(b) Distinguish between narrowband and wideband FM. With necessary block diagram discuss the Armstrong method of generating a WB-FM signal starting with a NB-phase modulator. (10)

(c) An FM radio channel is operating at a carrier frequency of 96.2 MHz with a channel bandwidth of 0.2 MHz. The bandwidth of the modulating signal is 15 kHz. The peak frequency deviation is 60 kHz. The carrier amplitude is 100 V rms. (15)

Determine:

- (i) the modulation index;
- (ii) bandwidth of the FM signal using Carson's rule.
- (iii) number of sidebands available within the channel bandwidth;
- (iv) power in the sidebands
- (v) total output power of the FM transmitter.

Use Bessel Function table.

EEE 309

SECTION – B

There are **FOUR** questions in this section. Answer any **THREE**.

Answer in brief and to the point.

5. Answer the following short questions:

(a) What was the basic purpose of sampling an analog signal that results in a PAM signal? With neat sketches, define natural and flat-topped sampling. (5)

(b) State the famous sampling theorem. Determine the Nyquist's sampling frequency for the message signal $x(t)$ represented by (4)

$$x(t) = -2.5 \sin(1000\pi t) + 0.7 \cos(6800\pi t) + 1.3 \cos(2000\pi t)$$

(c) Mention how you can reconstruct the original analog signal from its sampled version. (4)

(d) Draw the basic block diagram of a PCM transmitter. What is the function of a sampler in PCM? What type of sampler is used here and why? (6)

(e) Draw the binary-encoded digital pulse-train (voltage vs. time) corresponding to the bit-stream 10110011 at the output of the PCM transmitter. Also, draw the approximate waveshapes of the same pulse train at a distance of 2 kms from the transmitter. (Assume Cu-wire subject to noise and attenuation as the medium). Explain the causes for the change in shapes of the pulse train. (8)

(f) Explain how the effect of white noise can be totally eliminated in a PCM system. (4)

(g) Define quantization noise in PCM and state its effect on the quality of the received signal. How can we minimize quantization noise? (4)

6. (a) Calculate the bit-rate of a baseband digital signal in a single channel PCM system that uses the standard band-limited telephone channel. What is the equivalent bandwidth of this signal? Can we ideally pass this signal through an analog band-limited telephone channel (300 Hz-3400 Hz)? If not, why? (12)

How can we modify the encoded digital signal so that it can be passed through the same band-limited channel with minimum signal distortion?

(b) Define the basic digital modulation schemes with neat sketches and examples. Mention their relative merits and demerits. (12)

(c) Draw the synchronous detection circuit that can detect a PSK signal. Justify its proper operation using an appropriate example and mathematical relation. Can it be used for detecting an OOK signal? If so, explain how. (11)

EEE 309

7. (a) Comment on the bandwidth of human speech signals. In PCM, why do we still band-limit the speech signal between 300 Hz - 3400 Hz (an analog FDM band for a subscriber)? (11)

Calculate the bit-rate of a 30-channel PCM system (E1). Mention the purpose of source coding in digital communication.

- (b) What is multi-level modulation and what was the basic purpose of its introduction? (12)

Draw the block diagram of a QPSK modulator circuit using two BPSK modulators. Comment on the tasks of each of the two level shifters used. What are the phase states of the carrier when the bit-stream 10110001 is applied to the QPSK modulator?

- (c) Draw the block diagram of a QPSK demodulator. With proper mathematical equations and tables show that the signal extracted at the output of the demodulator will be exactly 10110001 as transmitted from the QPSK modulator in part (b). (12)

8. (a) Draw the block diagram of the simplest delta-modulator and demodulator, and explain their operations in brief. Mention the relative merit of delta modulation over PCM. On what type of signal can we apply delta modulation? What is granular/quantization noise in delta modulation? How can we minimize this noise? (12)

- (b) Define information and information capacity. Name and explain the two factors that limit the rate of information transmission through a communication channel. (11)

A message consists of the letters A, B, C and D. Suppose that each letter is coded into a sequence of two binary (on-off) pulses. The letter A is represented by 00, B by 01, C by 10 and D by 11. Each individual pulse interval is 5 ms. Calculate the average rate of information transmission if the different letters are equally likely to occur. (11)

- (c) Mention the essential properties of the set of orthogonal Pseudo-Noise (PN) codes to be used in DS-SS multiple access technique. Verify whether the following two sets of PN codes are orthogonal: (12)

$$x = [-1 \quad 1 \quad 1 \quad 1] \text{ and}$$
$$y = [-1 \quad 1 \quad -1 \quad -1].$$

Draw the block diagram of a 2-channel DS-SS CDMA scheme. Mention the function of each block using brief statements.

EEE 309 Communication Theory

TABLE A6.5 Table of Bessel functions^a

n\lx	$J_n(x)$								
	0.5	1	2	3	4	6	8	10	12
0	0.9385	0.7652	0.2239	-0.2601	-0.3971	0.1506	0.1717	-0.2459	0.0477
1	0.2423	0.4401	0.5767	0.3391	-0.0660	-0.2767	0.2346	0.0435	-0.2234
2	0.0306	0.1149	0.3528	0.4861	0.3641	-0.2429	-0.1130	0.2546	-0.0849
3	0.0026	0.0196	0.1289	0.3091	0.4302	0.1148	-0.2911	0.0584	0.1951
4	0.0002	0.0025	0.0340	0.1320	0.2811	0.3576	-0.1054	-0.2196	0.1825
5	—	0.0002	0.0070	0.0430	0.1321	0.3621	0.1858	-0.2341	-0.0735
6	—	—	0.0012	0.0114	0.0491	0.2458	0.3376	-0.0145	-0.2437
7	—	—	0.0002	0.0025	0.0152	0.1296	0.3206	0.2167	-0.1703
8	—	—	—	0.0005	0.0040	0.0565	0.2235	0.3179	0.0451
9	—	—	—	0.0001	0.0009	0.0212	0.1263	0.2919	0.2304
10	—	—	—	—	0.0002	0.0070	0.0608	0.2075	0.3005
11	—	—	—	—	—	0.0020	0.0256	0.1231	0.2704
12	—	—	—	—	—	0.0005	0.0096	0.0634	0.1953
13	—	—	—	—	—	0.0001	0.0033	0.0290	0.1201
14	—	—	—	—	—	—	0.0010	0.0120	0.0650

^aFor more extensive tables of Bessel functions, see Watson (1966, pp. 666-697), and Abramowitz and Stegun (1965, pp. 358-406).

L-3/T-2/EEE

Date : 24/12/2012

BANGLADESH UNIVERSITY OF ENGINEERING AND TECHNOLOGY, DHAKA

L-3/T-2 B. Sc. Engineering Examinations 2010-2011

Sub : **EEE 315** (Microprocessor and Interfacing)

Full Marks : 210

Time : 3 Hours

The figures in the margin indicate full marks.

USE SEPARATE SCRIPTS FOR EACH SECTION

SECTION - AThere are **FOUR** questions in this Section. Answer any **THREE**.

1. (a) Design an 8086 system with four $4k \times 8$ ROMs (address starting from 1F800H), eight $2k \times 4$ RAMS (address starting right after the last address of the ROMs) and one 8251A USART (base address 7800 H, 7801 H). Implement the even - odd addressing. Show the memory map and the connection schematic. (23)
- (b) Sketch and explain the timing diagram of the read cycle of 8086. (12)
2. (a) Interface an 8086 microprocessor to a 8 level paper tape reader through the PORT A of an 8255A PPI in such a way that whenever data is read from the tape the 8255 A sends an interrupt to the IR6 pin of an 8259 PIC. If the base addresses of the 8255A are F009H, F00BH, F00DH and F00FH while the base addresses of the 8259 PIC are F00AH and F00EH, respectively, draw the connection diagram of the system using DECODERS (IC74LS138) only. (15)
- (b) Write assembly codes to initialize the 8259 PIC and the 8255A-PPI properly so that there is a type 38 interrupt request when a data is read by the 8255A-PPI. Initialize the rest of the ports of the 8255A in mode 0. (15)
- (c) Write a code snippet for the function called during the interrupt so that data is read from the tape connected to the PORT A of the 8255A. (5)

8259 Control Words

	A ₀	D ₇	D ₆	D ₅	D ₄	D ₃	D ₂	D ₁	D ₀
ICW1	0	A ₇	A ₆	A ₅	1	LTIM	ADI	SNGL	IC4
ICW2	1	A ₁₅ /T ₇	A ₁₄ /T ₆	A ₁₃ /T ₅	A ₁₂ /T ₄	A ₁₁ /T ₃	A ₁₀	A ₉	A ₈
ICW3	1	S ₇	S ₆	S ₅	S ₄	S ₃	S ₂	S ₁	S ₀
ICW4	1	0	0	0	SFNM	BUF	M/S	AEOI	μPM
OCW1	1	M ₇	M ₆	M ₅	M ₄	M ₃	M ₂	M ₁	M ₀
OCW2	0	R	SL	EOI	0	0	L ₂	L ₁	L ₀

3. (a) Describe the functions of the \overline{DSR} , \overline{DTR} , \overline{RTS} , \overline{CTS} , TxD and RxD signals exchanged between a terminal and a modem. (10)
- (b) Write down the instructions of transmitting and receiving data through 8251A using polling method if the control register and data register addresses of the 8251 are FFF2H and FFF0H, respectively. (10)

Contd P/2

EEE 315

Contd ... Q. No. 3(b)

8251 Control Words

MW	S2	S1	EP	PEN	L2	L1	B2	B1
CW	EH	IR	RTS	ER	SBRK	RxE	DTR	TxE
SW	DSR	SYNDET	FE	OE	PE	TXE	RXRDY	TXRDY

- (c) Why must you use an IRET instruction rather than the regular RET instruction at the end of an interrupt services routine? (5)
 - (d) What response will an 8086 microprocessor show if it receives a divide-by-zero interrupt exactly at the same time when an NMI occurs? Why? (5)
 - (e) What is the purpose of interrupt vector table? What is its range in the SDK Board? How many interrupts can it accommodate? (5)
4. (a) Draw a circuit diagram using timer 0 of an 8254 timer/counter IC that can be used to determine power line failure for an 8086 system considering the internal addresses of the 8254 to be FF00H, FF01H, FF10H and FF11H, respectively. If the power line signal is 220 V, 50Hz and the 8254 is connected to a 1 MHz clock, what can be a possible count value loaded to the counter and why? In which mode will you operate the counter? Write an assembly code to initialize the counter. (20)

8254 Control Words

SC1	SC0	RW1	RW0	M2	M1	M0	BCD
-----	-----	-----	-----	----	----	----	-----

- (b) Describe all the methods of reading the count value from the 8254 counter. (15)

SECTION - B

There are **FOUR** questions in this Section. Answer any **THREE**.

- 5. (a) Design a system with 28 × 8 LED matrix, shown in figure for Q 5(a), and a microcontroller, so that the system can display a 8 × 16 image. Also, write a program for that microcontroller system that can display an 8 × 16 image stored in the memory in the following manner: Each 8 LED row is represented by an 8 bit unsigned integer, where each bit of the integer represents the ON or OFF state, total 16 integers are given in an array A, representing each row. Use appropriate delays in your code, and in comment, explain why the particular delay values were used.
Char A[] = {0xAB 0xBC ...} // image array
(you do not need to declare A, assume it is already defined in code. Also, do not redraw the LED matrix, and use bubbles to show connections) (15)

EEE 315

Contd ... Q. No. 5(a)

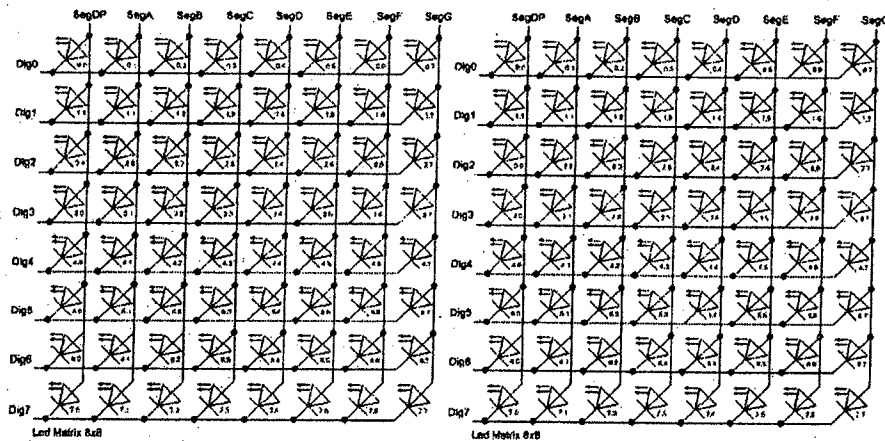

Figure for Question 5(a)

(b) For the given H-bridge motor driver, design a microcontroller system, that has 2 switches. Pressing switch no 1 will toggle the On/Off state of the motor. Pressing switch no 2 will reverse the direction of rotation of the motor. For your design, use the p1, p2, p3 and p4 bubbles, and do not redraw the H-bridge. Write appropriate code for the system.

(15)

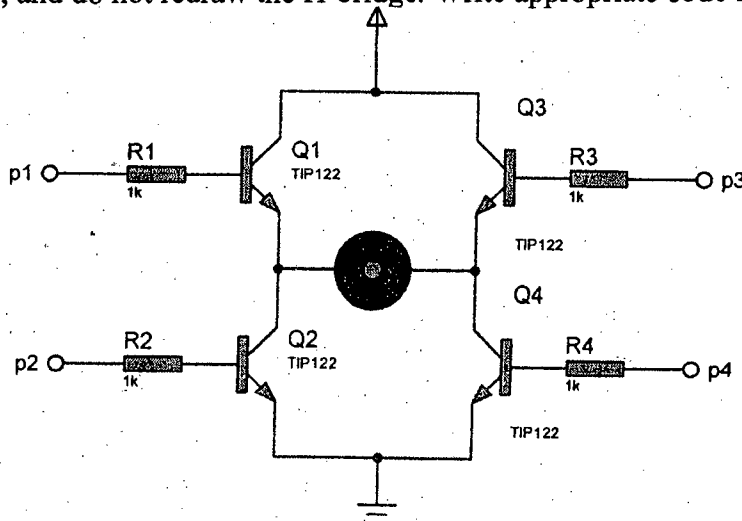

Figure for Question 5(b)

(c) What are the differences between a microprocessor and a microcontroller?

(5)

6. (a) The following statements are part of a continuous program. Fill up the values of the appropriate flags after sequential execution of each instruction.

(15)

- (i) ADD AX, CX
- (ii) ADD BX, AX
- (iii) SUB BX, 1h
- (iv) INC BL
- (v) NEG DX
- (vi) DIV CX
- (vii) TEST DX, DX

EEE 315

Contd ... Q. No. 6(a)

	ZF	SF	CF	OF	PF	AX	BX	CX	DX
Initial	0	0	0	0	0	0000h	FFFFh	8001h	0000h
i.									
ii.									
iii.									
iv.									
v.									
vi.									
vii.									

(b) A DB r, t is a complex number given in polar form ($r \angle t$). r and t are arbitrary constants in decimal form, t given in degree. Write an assembly program that will multiply two such complex numbers A and B and put the result in M and divide A by B and put the result in D, where B, M and D are also polar form complex number defined in the same manner as A. (10)

(c) The address C82F:1000 contains an instruction. (i) What should be the value of IP for a program to execute that instruction, if value of CS for that program is C000h? (ii) What can be the minimum value of CS of a particular program, for which the instruction C82F:1000 can be executed by that program, without help of any jump commands. (10)

7. (a) For each of the following statements state the addressing mode of the source and destination operand. If the instructions are executed sequentially, write the content of the memory after execution of all the instructions. (10)

Memory Offset	Content
1000h	12h
1001h	45h
1002h	34h
1003h	67h
1004h	78h
1005h	17h
1006h	23h

Instructions:

- (i) MOV BX, 1003h
- (ii) MOV AX, [BX]
- (iii) MOV SI, 1004h
- (iv) MOV DI, SI
- (v) XCHG [SI], [DI]
- (vi) MOV [SI], [1005]

EEE 315

Contd ... Q. No. 7

(b) Consider the following code. What will be the value of R after execution of the code?

The code performs a function. State what is that function.

(10)

```
MOV AL, 1
MOV BL, N
CALL Proc1
MOV AL, R   MOV R, AL
HLT
Proc1:
TEST BL, 0FFh
JZ, ret1:   JZ   ret1
MUL BL
DEC BL
CALL Proc1
ret1 : RET
N DB 5
R DB ?
HLT
```

(c) Define with examples: (any three)

(15)

- (i) Immediate Addressing
- (ii) Unconditional Jump
- (iii) Register Indirect Addressing
- (iv) Divide Overflow

8. (a) A palindrome is a word or phrase that may be read the same way in either direction. (Example "MADAM IM ADAM"). Write an assembly program that will test a string whether it is a palindrome. (spaces are ignored while testing for palindrome)

(15)

(b) In the assembly code given in table, there are some syntax as well as logical errors. Find the errors and correct them with proper explanation. Note that the first of the two erroneous statements is always correct, and all other consecutive statements must be corrected if necessary. Provide the corrections in a tabular form given in the Figure for Question 8(b).

(15)

Signature

L-3/T-2/EEE

Date : 17/12/2012

BANGLADESH UNIVERSITY OF ENGINEERING AND TECHNOLOGY, DHAKA

L-3/T-2 B. Sc. Engineering Examinations 2010-2011

Sub : **EEE 371** (Power System II)

Full Marks: 210

Time : 3 Hours

USE SEPARATE SCRIPTS FOR EACH SECTION

The figures in the margin indicate full marks.

SECTION - A

There are **FOUR** questions in this Section. Answer any **THREE**.

All the symbols have their usual meanings.

1. (a) Using the concept of synchronizing power coefficient, show that the operating point of an alternator, $\delta \leq 90^\circ$ for a stable system. (15)

- (b) Consider the following single line diagram. All impedances are in P.u. (15)

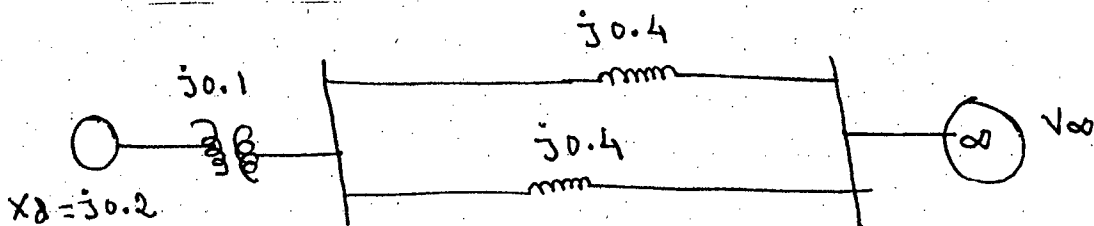

Fig. for Q. 1 (b)

The machine is delivering 1.0 p.u. power and both the terminal and infinite bus voltages are 1.0 p.u. Determine (i) the power-angle equation of the system, (ii) corresponding swing equation if $P_m = 1.0$ p.u., (iii) operating point of the system and (iv) the value of synchronizing power coefficient.

- (c) What are the factors that affect the transient stability of a system? (05)

2. (a) What is sub-synchronous resonance? Show that $f_r = f\sqrt{k}$. (05)

- (b) Determine the value of series capacitor to increase the power transfer capability of a transmission line by 3 times. Given that the inductive reactance of the line is 5Ω and frequency is 50 Hz. (10)

- (c) Consider two buses, B_1 and B_2 , with voltages $V_1 \angle -2^\circ$ p.u. and $V_2 \angle 0^\circ$ p.u. Using a phase shifting transformer, the voltage of B_1 is changed to $V_1 \angle -3^\circ$ p.u. Determine the % increase of power flow between buses. (10)

- (d) For the following table, calculate % TDD if $I_L = 100$ A. (10)

Harmonic order	Individual current harmonic (A)
2	0.2
3	0.4
4	0.6
5	0.8

Contd P/2

EEE 371

3. (a) For the following single line diagram, explain and derive the equal area criterion. (18)

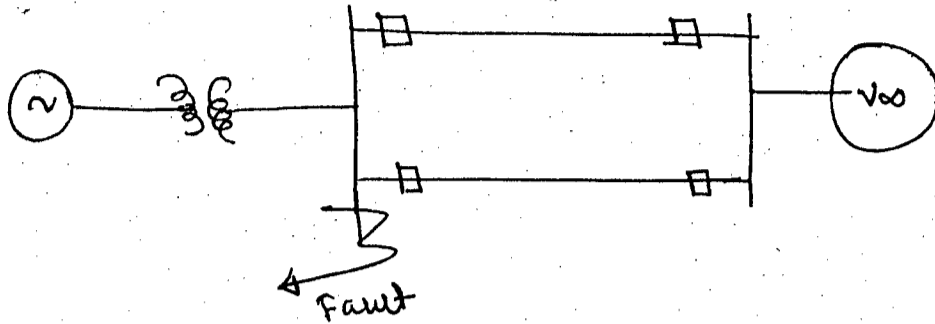

Fig. for Q. 3(a)

- (b) For the network shown in Fig. 3(a), derive the expressions of (i) critical clearing angle and (ii) critical clearing time. Also explain their significances. (17)
4. (a) For a power system, the power angle equations are, (10)

Before the fault: $P_{\max} \sin\delta = 2.10 \sin\delta$

During the fault: $r_1 P_{\max} \sin\delta = 0.808 \sin\delta$

After the clearance of fault: $r_2 P_{\max} \sin\delta = 1.50 \sin\delta$

Mechanical input, $P_m = 1.0$ p.u.

Determine the critical clearing angle of the system.

- (b) For an overhead transmission line, considering span = L, weight/unit length of conductor = W and horizontal tension = H, derive the hyperbolic equation of length of the conductor, catenary curve, sag and tension. (20)
- (c) What is FACTS technology? Write down its advantages. (05)

SECTION - B

There are **FOUR** questions in this Section. Answer any **THREE**.

5. (a) Derive the expression for inductance of a single phase composite conductor transmission line in terms of GMD and GMR. (13)
- (b) The distance between conductors of a single phase line is 10 ft. Each of its conductors is composed of six strands symmetrically placed around one center strand (total 7 strands). The diameter of each strand is 0.1 in. Show that D_s of each conductor is 2.177 times the radius of each strand. Find the inductance of the line in mH/mi. (12)
- (c) Explain, why bundled conductor lines have lower inductance than single-conductor lines of the same area of cross-section. (10)

EEE 371

6. (a) Derive an expression for the capacitance to neutral in farads per meter of a single-phase line, taking into account the effect of ground. (13)

(b) The line in Q. 6(a) is composed of two solid circular conductors, each having a diameter of 0.229 in. The conductors are 10 ft apart and 25 ft above ground. Calculate and compare the capacitance to neutral per meter with and without the effect of ground. (10)

(c) Six conductors of ACSR Drake constitute a 50-Hz double-circuit 3 ϕ line arranged as shown in the Fig. Find the capacitive reactance to neutral (in Ω -mi) and the charging current in A/mi per phase and per conductor at 132 kV. Consider GMR = 0.0373 ft and the outside diameter of the conductor as 1.108 in. (12)

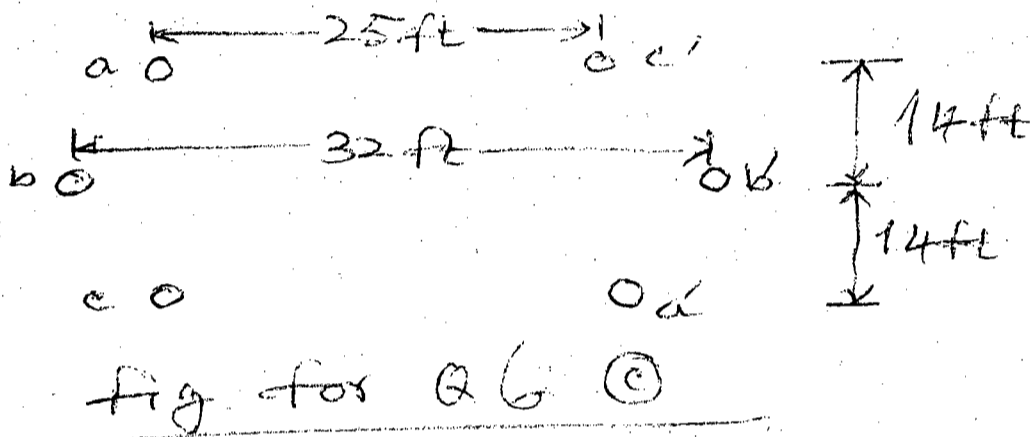

7. (a) Discuss stress distribution in a HVDC cable. (12)

(b) Explain how capacitance between conductors (C_c) and that between conductor and sheath can be calculated through various methods. (12)

(c) A single-core 5 km long cable has an insulation resistance of 0.4 m Ω . The core diameter is 20 mm and diameter of the cable over the insulation is 50 mm. Calculate the resistivity of the insulating material. (11)

8. (a) Explain with appropriate diagrams the various types of HVDC transmission systems. (12)

(b) Present an economic comparison between a 3 ϕ AC line and a 2-wire DC line. (12)

(c) An existing 3 ϕ , double-circuit AC line is to be converted to three-circuit DC line. Assuming same insulation level and unity p.f. in the AC systems. Show that (11)

(i) the ratio of power transmitted by DC to that by AC is equal to $\sqrt{2}$

(ii) the ratio of percentage loss by DC to that by AC is equal to $1/\sqrt{2}$.

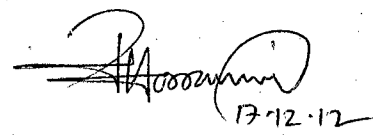
17-12-12

L-3/T-2/EEE

Date : 17/12/2012

BANGLADESH UNIVERSITY OF ENGINEERING AND TECHNOLOGY, DHAKA

L-3/T-2 B. Sc. Engineering Examinations 2010-2011

Sub : EEE 351 (Analog Integrated Circuits)

Full Marks: 210

Time : 3 Hours

USE SEPARATE SCRIPTS FOR EACH SECTION

The figures in the margin indicate full marks.

SECTION - A

There are **FOUR** questions in this Section. Answer any **THREE**.

All the symbols and notations used in this part have their usual meanings.

- 1. (a) Briefly describe different types of noises and their origins those may corrupt signal processed by integrated circuits. **(12)**
- (b) Determine the input-referred noise voltage for the circuit shown in Fig. for Q. No. 1(b). **(15)**

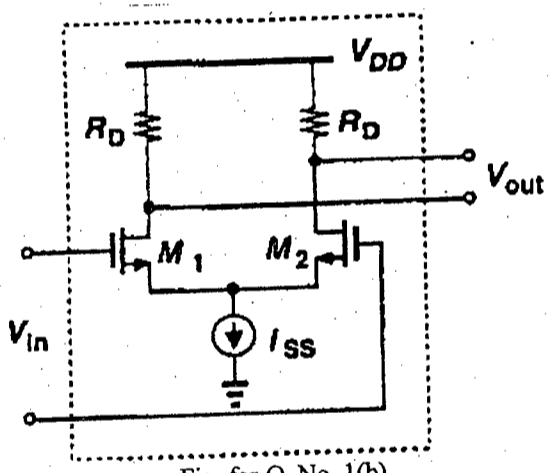

Fig. for Q. No. 1(b)

- (c) For an NMOS current source, calculate the total noise in the drain current for a band from 100 Hz to 10 MHz. **(08)**
- 2. (a) Given a short account of the methods for supply-independent biasing, temperature-independent references and constant G_m biasing for ICs. Your arguments should be supported by proper circuits and mathematics. **(24)**
- (b) Assume $\lambda \neq 0$, in Fig. for Q. No. 2(b), estimate the change in I_{out} for a small change in the supply voltage V_{DD} . **(11)**

Contd P/2

EEE 351

Contd Q. No. 2(b)

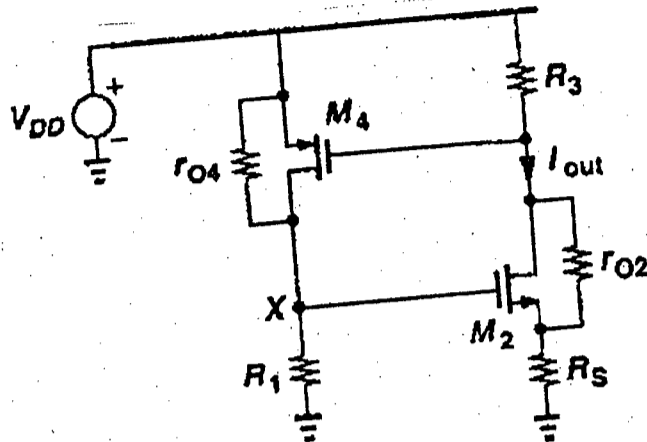

Fig. for Q. No. 2(b)

3. (a) Describe the operation of the unity-gain sampler in slow motion. Draw a scheme to co-ordinate the switches of the unity-gain sampler from a single clock. (15)
- (b) Draw the precision multiply-by-2 circuit of a non-inverting amplifier. Also illustrate the differential realization of non-inverting amplifier. (12)
- (c) Convert the continuous-time integrator shown in Fig. for Q. No. 3(c) into a discrete-time integrator such that it becomes parasitic-insensitive. (08)

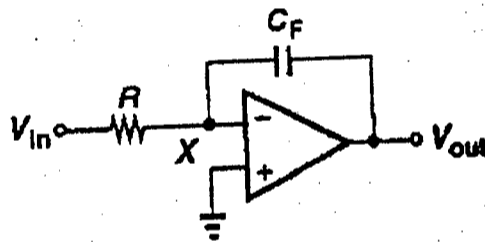

Fig. for Q. No. 3(c)

4. (a) What are PD, FD and PFD? Implement a simple PLL in CMOS technology. (08)
- (b) Improve the charge-pump PLL such that it can be more dynamically stable and can reduce ripple on the control line. (12)
- (c) From the Fig. for Q. No. 4(c), draw the net current and the effect of up/down current mismatch on V_{cont} (in reference to CP-PLL). (08)

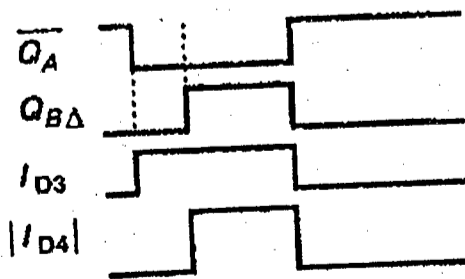

Fig. for Q. No. 4(c)

- (d) Mention some applications of PLL/DLL. (07)

EEE 351

SECTION - B

There are **FOUR** questions in this Section. Answer any **THREE**.

5. (a) The drain-source current (I_{ds}) of the NMOS transistor in linear region is given by the following equation where the symbols have their usual meaning. (7)

$$I_{ds} = \mu_n C_{ox} \left(\frac{W}{L} \right) \left[(V_{gs} - V_t) V_{ds} - \frac{1}{2} V_{ds}^2 \right]$$

Starting from the above equation derive the drain-source current of the NMOS transistor in the saturation region and show that it does not depend on the drain-source voltage.

- (b) For the circuit shown in Fig. for Q. 5(b) sketch I_x and the transconductance of the transistor as a function of V_x . The following parameters are given: $\lambda = 0.1$, $\gamma = 0.45$, $\phi_F = 0.45$ V, $V_{TH0} = 0.7$ V, $\mu_n C_{ox} = 120 \mu A/V^2$, $W/L = 10$. (14)

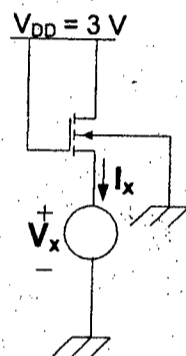

Fig. for Q 5(b)

- (c) A designer has to use a large MOSFET transistor with gate width, $W = 200 \mu m$ and gate length, $L = 2 \mu m$ in a certain analog circuit. Finding that the capacitances become unacceptably large he decided to split it into 2 MOSFET connected in parallel. Show the layout of the MOSFET and calculate the drain body (C_{DB}) and source body (C_{SB}) capacitance of the transistor for both of the cases. The source and the body of the transistor is connected with ground potential and the drain is connected with 5 V supply. The following data are given: drain/source length (E) = $10 \mu m$, $C_{j0} = 0.15$ pF/ μm^2 , $C_{jsw0} = 0.1$ pF/ μm , $\phi_B = 0.6$ V, $m_j = 0.6$, $m_{jsw} = 0.4$, where the symbols have their usual meanings. (14)

6. (a) For the common source amplifier with diode connected load as shown in Fig. for Q. 6(a), show that the voltage gain can be expressed as a function of the aspect ratio of transistors M_1 and M_2 and η_2 (g_{mb2}/g_{m2}), where the symbols have their usual meanings. (15)

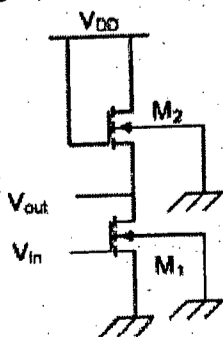

Fig. for Q 6(a)

Contd P/4

EEE 351

Contd Q. No. 6

- (b) Calculate the voltage gain V_{out}/V_{in} of the cascade stage shown in Fig. for Q. 6(b). Assume $\lambda = 0$. (20)

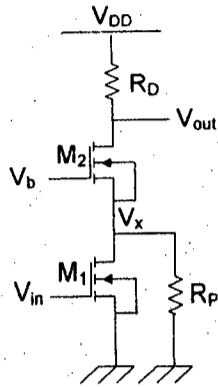

Fig. for Q 6(b)

Now, in the above circuit assume $R_p = \infty$ (infinity), and $\lambda = \gamma = 0$. Also assume threshold voltage of M_1 and M_2 as V_{TH1} and V_{TH2} , respectively. Sketch the transfer characteristics (V_{out} vs. V_{in}) and V_x vs. V_{in} curve as V_{in} varies from 0 to V_{DD} .

7. (a) In the differential pair circuit shown in Fig. for Q. 7(a), the transistor M_1 and M_2 are identical having an aspect ratio of W/L . Assume M_1 and M_2 are saturated and $\lambda = 0$. For the differential input voltage V_{in1} and V_{in2} , show that the overall transconductance of the differential pair G_m defined as $G_m \frac{\partial \Delta I_D}{\partial \Delta V_{in}}$ becomes maximum at $\Delta V_{in} = 0$ and calculate this maximum value of G_m . Also find the value of ΔV_{in} for which G_m falls to zero. (20)

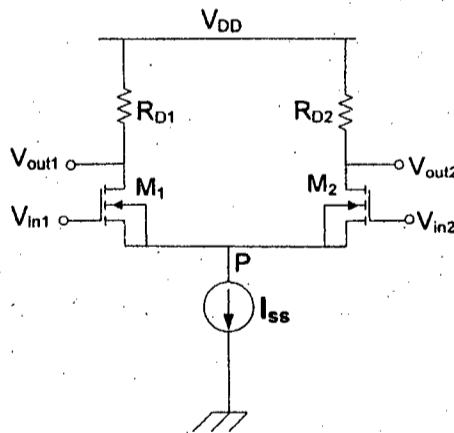

Fig. for Q 7(a) and 7(b)

- (b) In the circuit shown in Fig. for Q. 7(b), a common mode voltage V_{cm} is applied at both V_{in1} and V_{in2} . Let $V_{DD} = 3$ V, $K'_n (W/L) = 4$ mA/V² for both transistors, $V_t = 0.5$ V, $I_{SS} = 0.4$ mA, and $R_{D1} = R_{D2} = 2.5$ K Ω and neglect channel length modulation. (15)

- (i) Find V_{OV} and V_{GS} for each transistor
- (ii) For $V_{cm} = 0$, find V_S , I_{D1} , I_{D2} , V_{D1} and V_{D2}
- (iii) What is the highest value of V_{cm} for which M_1 and M_2 remains in saturation.

Make necessary assumptions.

EEE 351

8. (a) A basic current mirror circuit is shown in Fig. for Q. 8(a). Aspect ratio of M_1 and M_2 are $(W/L)_1$ and $(W/L)_2$, respectively and channel length modulation parameter of both transistor is λ . Find the drain current I_{D2} in terms of I_{D1} . (12)

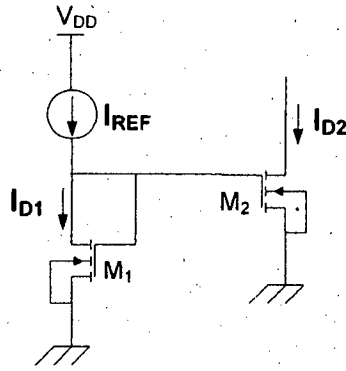

Fig. for Q 8(a)

- (b) In order to suppress the effect of channel length modulation, a cascode current source can be used. Show the circuit diagram of a cascode current source and explain its operation. Explain how cascode bias voltage V_b can be generated. (13)

- (c) Show the circuit diagram of a differential amplifier with NMOS input and PMOS active current mirror load and a realistic steering current source (I_{SS}). Briefly explain the operation of the circuit. (10)
