

SECTION – A

There are **FOUR** questions in this section. Answer **Q. No. 1** and any **TWO** from the rest.

1. What is Total Station Survey? Describe Total Station Setup and operation. (5+25)
2. What are the applications of Total Station? What are the advantages of Digital Levels? (10+10)
3. (a) What is surveying? Classify and explain. (10)
(b) What is Traverse surveying? Classify and explain. (10)
4. Write short notes on any four (4×5=20)
 - (a) E.D.M
 - (b) Chain Survey
 - (c) Offset Stuffs
 - (d) Chain
 - (e) Plane table surveying

SECTION – B

There are **FOUR** questions in this section. Answer any **THREE**.

5. What are primary and secondary data? Explain different sources for primary and secondary data collection? Define different types of variables used in statistics. (23 1/3)
6. Review and compare the following methods of data collection with advantages and disadvantages: surveys, indepth interview, focus groups, observations, tests, document studies and case studies. (23 1/3)
7. What is a questionnaire? Describe the factors to be considered while framing questionnaires with examples. (23 1/3)
8. What is a report? Describe the stages involved in writing a report with checklist. (23 1/3)

Sub : **CE 467** (Structure VI: Elements of Building Structure)

Full Marks : 140

Time : 3 Hours

The figures in the margin indicate full marks.

USE SEPARATE SCRIPTS FOR EACH SECTION

SECTION – AThere are **FOUR** questions in this section. Answer any **THREE**.

Assume any reasonable value for missing data.

1. (a) Vierendeel Steel Trusses, spaced 20' apart,, are used to support a slab carrying a total factored load of 30 psf (Figure 01). Each truss consists of 10 panels 6 ft × 10 ft each. Determine shear force of chords at panel 3, 4 and bending moment of web between panel 3 and 4. (14)
- (b) Differentiate between: (9 1/3)
 - (i) Pretensioning and Posttensioning
 - (ii) Bonded and Unbonded Tendons
 - (iii) 'vault' and 'barrel shell'
2. (a) A concrete rectangular beam 500 mm by 750 mm has a simple span of 7.3 m and is loaded by a uniform load of 40 KN/m excluding its own weight. The beam is prestressed with a parabolically curved tendon as shown in Figure 02 that produces an effective prestress of 1620 KN. Compute extreme fiber stresses at a location 3.0 m from left support applying 2nd concept (Prestressing for combination of high strength steel with concrete). Assume self weight of the beam as 5 KN/m. (15)
- (b) Briefly explain the first concept "Prestressing to transform concrete into an elastic material" showing the effect of eccentricity of tendon. (8 1/3)
3. Write down the difference between meridional thrust and hoop stress in a dome. Derive the equation of hoop stress in a dome due to a concentrated load at the crown. (23 1/3)
4. (a) Why high strength concrete and steel are used in prestressed concrete? (4 1/3)
- (b) A posttensioned bonded concrete rectangular beam has a prestress of 1650 KN in the steel immediately after prestressing, which eventually reduces to 1450 KN due to losses. The beam carries a uniformly distributed live load of 4.0 KN/m and three point live loads of 40 KN in addition to its own weight of 6.0 KN/m (Figure 03). Compute the extreme fibre stresses in the concrete (using gross section) at a location 5.0 m from left support, (i) under the initial condition with full prestress and no live load and (ii) under the final condition, after the losses have taken place and with full live load. (19)

CE 467 (ARCH)

SECTION – B

There are **FOUR** questions in this section. Answer any **THREE**.

5. Draw the shear force and bending moment diagrams for all the girders of the frame as shown in Figure 4. Use Cantilever method. Values in circles indicate cross sectional areas of the column. (23 $\frac{1}{3}$)
6. Using approximate method of analysis for gravity loads, draw the bending moment diagrams for all the columns and girders and also the axial force diagrams of the columns for the frame shown in Figure 4. Use 2 k/ft uniformly distributed load (UDL) acting downwards on all the girders and disregard the lateral loads shown. All the columns have same cross section and are uniform throughout the height. Use un-factored load. (23 $\frac{1}{3}$)
7. (a) Describe architectural significance of regular structures and also the structural benefits that can be utilized for the regularity. (4)
(b) Determine design dead load (DL) and live load (LL) for the column C1 in Figure 5 at the ground floor level of a 9 storied building. Given that, slab thickness = 6 in., floor finish = 25 psf, partition wall loading = 50 psf and live load = 60 psf. Consideration for self-weight of beams and columns is not necessary. Now, design this column as a square tied column to support gravity loads only using $f'_c = 4$ ksi and $f_y = 60$ ksi. Assume a proper steel ratio within limits and design the necessary ties also. (19 $\frac{1}{3}$)
8. (a) If a service core is constructed with reinforced cement concrete, what are the advantages it can add from the view point of structural stability? (5 $\frac{1}{3}$)
(b) A three storied shear wall is subjected to lateral forces as shown in Figure 6. The wall is 15 feet long and 12" thick. Design the shear wall for both moment and shear. All the relevant formulae are provided in Annexure 1. Use $f'_c = 3$ ksi and $f_y = 60$ ksi. (18)
-

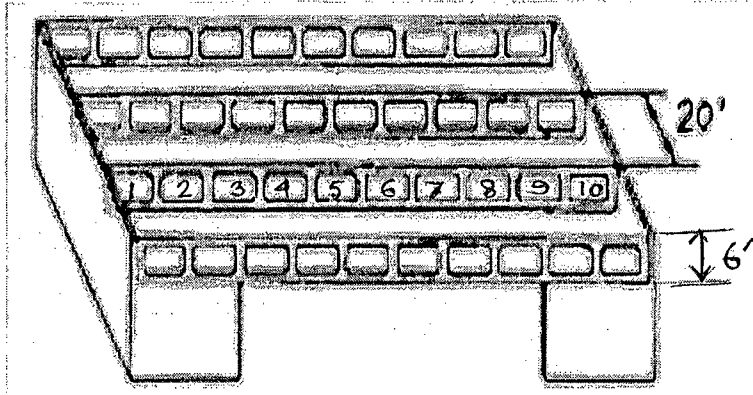

Figure 01

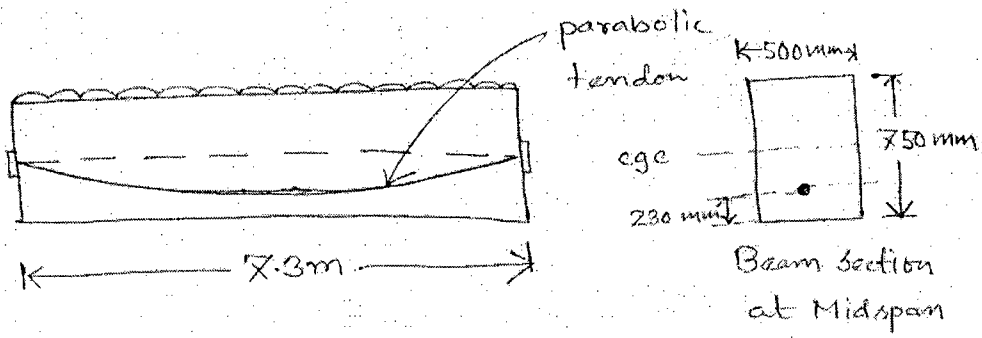

Figure 02

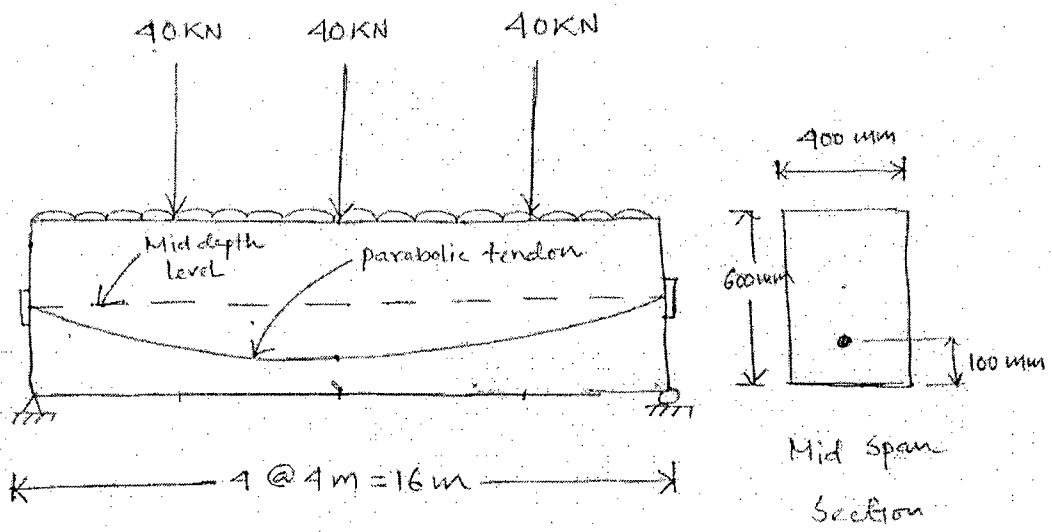

Figure 03



$$= 4 =$$

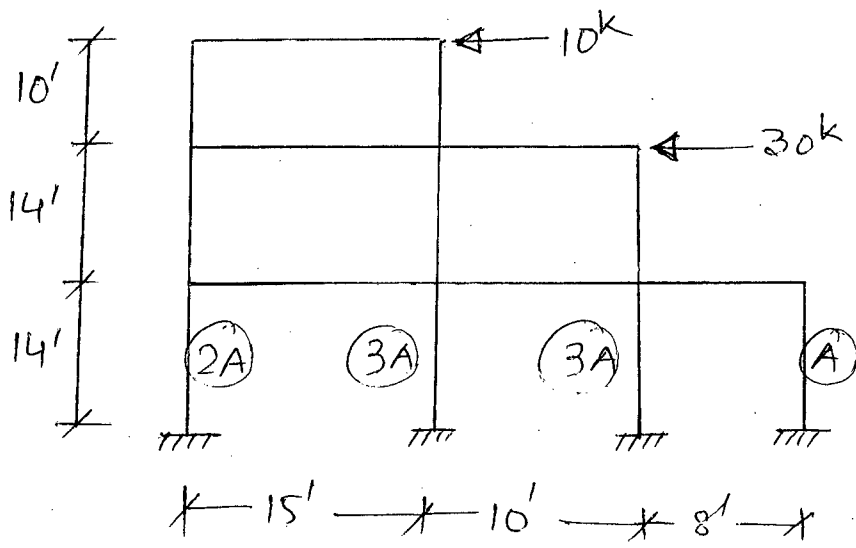

Figure - 4

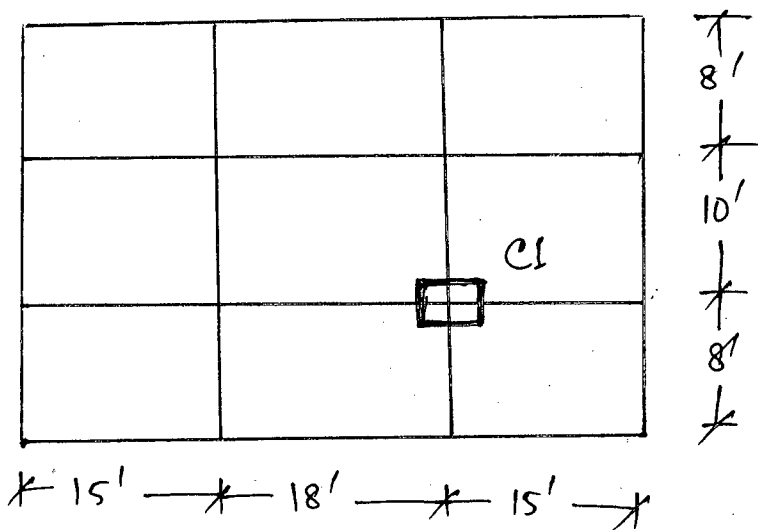

Figure - 5

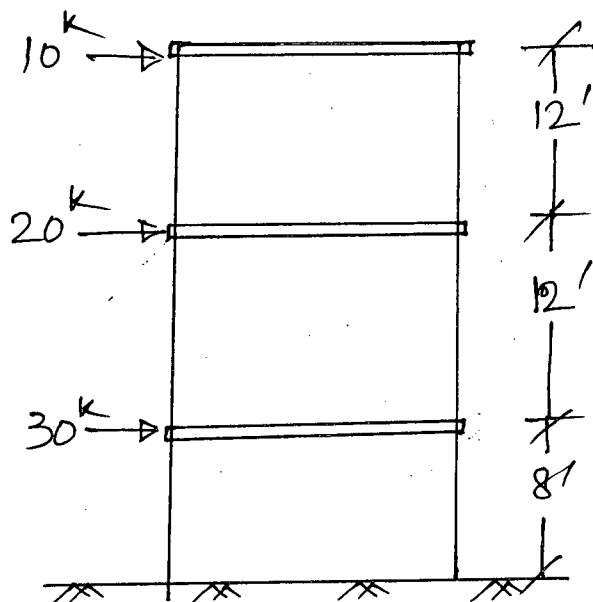

Figure - 6

5

ANNEXURE 1

$$f_y = 60 \text{ ksi}, \quad f'_c = 3 \text{ ksi}, \quad \phi = 0.85$$

$$V_u = \phi V_n \leq 10\phi\sqrt{f'_c}dh, \quad d = 0.8 l_w$$

$$V_c = 2\sqrt{f'_c}dh$$

$$\frac{A_{vh}}{S_2} \geq \frac{V_u - \phi V_c}{\phi f_y d}, \quad S_2 \leq \frac{l_w}{5}, \quad 3h \text{ or } 18 \text{ in}$$

$$\frac{A_{vw}}{S_1} \geq \left[0.0025 + 0.5 \left(2.5 - \frac{h_w}{l_w} \right) \left(\frac{A_{vh}}{S_2 h} - 0.0025 \right) \right] h$$

$$S_1 \leq \frac{l_w}{3}, \quad 3h \text{ or } 18 \text{ in}$$

$$\frac{A_{vh}}{S_2} (\text{min}) = 0.0025h$$

$$\frac{A_{vw}}{S_1} (\text{min}) = 0.0025h$$

$$\phi M_n = \phi \left[0.5 A_{st} f_y l_w \left(1 - \frac{z}{l_w} \right) \right]$$

$$\frac{z}{l_w} = \left(\frac{1}{2 + \frac{0.85\beta_1 l_w h f'_c}{A_{st} f_y}} \right)$$

SECTION – A

There are **FOUR** questions in this section. Answer **Q. No. 1** and any **TWO** from the rest.

1. (a) Explain Architect Peter Eisenman's approach towards architecture which is known as Post-humanism. (17)
- (b) Similarities of three types of architecture are seen in Eisenman's design. Name the three types of architecture. (3)
2. (a) Briefly describe the three major phases of criticism towards Modern movement. Cite name of person or groups that were involved in the criticism. (5)
- (b) Why do you think some of the most successful building designed in the last century have been custom houses? (5)
- (c) What were the two types of 'gaps' that resulted in many design that we regard as failures? Explain the 'gaps'. (5)
- (d) Explain why it is claimed that modern building have not been functional enough? (5)
- (e) What is the problem of design field that is based on a naïve stimulus-response (S-R) model of the relationship between environment and human behaviour? (5)
3. (a) Write the differences between first and second machine aesthetics. (5)
- (b) Write about architectural characteristics of Sculptural form, Extreme articulation, and the second machine aesthetics found in Pompidou Center, Paris. Draw sketches if needed. (15)
- (c) Why Geometric expressionism become popular in the corporate world? (5)
4. (a) Who were the architects known as "the Five"? (5)
- (b) Richard Meier's early white pavilions are inversion of corbusian syntax. Describe this statement with the help of Meier's early white pavilions. (20)

ARCH 447

SECTION – B

There are **FOUR** questions in this section. Answer **Q. No. 5** and any **TWO** from the rest.

5. (a) What was Architect Michale Grave's attitude towards architecture. Explain elaborately. (10)
- (b) Name the two artists that Charles Jencks mentioned while describing the south façade of the Snyderman house by Michale Graves. (10)
6. (a) Why the projects built in Italy and Japan under the historicist works were more successful than in North America? (2)
- (b) Who was the famous 17th Century Architect who influenced Portoghesi's early works? (3)
- (c) Describe Paolo Portoghesi's architecture through the project of Mosque and Islamic Centre in Rome, Italy. (20)
7. Explain how the Neo-Vernacular architects such as Darbourne, Darke, Maguire and Murray Changed the scenario of public housing in 1960s through their design of livington street housing and student housing, University of Surrey, England. (25)
8. Explain the characteristics of Architect Chales Moore's design with the help of his projects. (25)
-

SECTION – A

There are **FOUR** questions in this section. Answer **Q. NO. 1** and any **TWO** from the rest.

1. Write short notes on **(3×8=24)**
- (a) Human Settlements
 - (b) Dwelling
 - (c) Urbanization
2. (a) Define Adequate Shelter. **(5)**
- (b) What are the social and economical roles of human settlements? **(9)**
- (c) Explain with examples the private and public modes of dwelling. **(9)**
3. (a) Explain Modern House. **(5)**
- (b) 'House is an institution for dwellers' ideal living environment' – Explain. **(9)**
- (c) Elaborate the three levels of meaning of housing with examples. **(9)**
4. (a) Define Slum. **(5)**
- (b) What are the major causes and policy responses to rural-urban migration? **(9)**
- (c) Explain the types homelessness in the cities of Bangladesh. **(9)**

SECTION – B

There are **FOUR** questions in this section. Answer **Q. No. 5** and any **TWO** from the rest.

5. Write short notes on: **(3×8=24)**
- (a) Housing Process
 - (b) Self help housing
 - (c) Housing delivery system

ARCH 473

6. (a) Differentiate Heteronomy, Antarchy, and Autonomy in housing. (5)
(b) Compare the objectives of providing and supporting housing paradigms. (9)
(c) Discuss the ends, means and ways of housing. (9)

 7. (a) What are the key features of the World Bank's housing policies for the poor. (5)
(b) Explain 'Myth of Marginality' for its contribution to housing policy change. (9)
(c) Discuss the background, rationale and objectives of Global Shelter Strategy. (9)

 8. (a) Draw the multi-scalar and multi-dimensional framework of sustainable housing. (5)
(b) What are the attributes of sustainable housing? (9)
(c) How would you differentiate between building and shelter sustainability? (9)
-