

BANGLADESH UNIVERSITY OF ENGINEERING AND TECHNOLOGY, DHAKA

L-3/T-2 B. Sc. Engineering Examinations 2013-2014

Sub : **IPE 493** (Industrial Management)

Full Marks: 210

Time : 3 Hours

USE SEPARATE SCRIPTS FOR EACH SECTION

The figures in the margin indicate full marks.

SECTION – AThere are **FOUR** questions in this section. Answer any **THREE**.

1. (a) Discuss different organizational design approaches. (15)
 (b) Assume that Product Z is made of two units of A and four units of B. A is made of three units of C and four of D. D is made of two units of E. Lead times for purchase or fabrication of each unit to final assembly are: Z takes two weeks; A, B, C, and D take one week each; and E takes three weeks. 50 units of Z are required in Period 10 and 20 units of D are required in Period 7. Inventory on hand for A is 15, for B is 20. Assume that there is currently no inventory on hand for the other items. (20)
 - (i) Show the product structure tree.
 - (ii) Develop an MRP planning schedule showing gross requirement, net requirements, order release and order receipt dates.

2. (a) Discuss Henry Fayols fourteen principles of management. (20)
 (b) A certain automobile repair shop uses 925 tires a year which are priced as follow: for 1 to 49 units, \$6.5 each; for 50 to 99 units, \$5.75 each; and for 100 units or more, \$4.5 each. It costs approximately \$20 to prepare an order and receive it and holding costs are 80 percent of purchase price per unit on an annual basis. Determine the optimal order quantity and the minimum total annual cost. (15)

3. (a) Discuss different aspects of quality that customers may value. (20)
 (b) In 'Funland Toy Factory', a worker has to produce 360 units of toys. The standard task is 80 units, where the low task is 75% of the standard task. If the wage rate is \$30 per hour and the worker takes 4 hours to complete the task, than calculate his earnings per hour under Rowan plan. How much more or less he will earn per hour if the company uses Halsey plan? Assume a worker has 40% contribution in his saved time. (15)

4. (a) Describe Hemner's rules for behavioral modification with necessary examples. (13)
 (b) Discuss five basic sources of power with necessary examples. (12)
 (c) Discuss different advantages and disadvantages of using 'product layout'. (10)

Contd P/2

IPE 493

SECTION – B

There are **FOUR** questions in this section. Answer any **THREE**.

5. (a) Describe how market can be segmented on the basic of demographic variables with suitable examples. (17)
- (b) Explain the five forces that determine the intrinsic long-run attractiveness of a market with suitable examples. (10)
- (c) Define the following terms: (8)
- (i) Marketplace
 - (ii) Marketspace
 - (iii) Metamarket
 - (vi) Customerization
6. (a) Paul Swanson has an opportunity to acquire a franchise from The Yogurt Place, Inc., to dispense frozen yogurt products under The Yogurt Place name. Mr. Swanson has assembled the following information relating to the franchise:
- (i) A suitable location in a large shopping mall can be rented for \$3,500 per month.
 - (ii) Remodeling and necessary equipment would cost \$270,000. The equipment would have a 15-year life and an \$18,000 salvage value. Straight-line depreciation would be used, and the salvage value would be considered in computing depreciation.
 - (iii) Mr. Swanson estimates that sales would total \$300,000 per year.
 - (iv) Ingredients would cost 20% of sales.
 - (v) Operating costs would include \$70,000 per year for salaries, \$3,500 per year for insurance, and \$27,000 per year for utilities. In addition, Mr. Swanson would have to pay a commission to The Yogurt Place, Inc., of 12.5% of sales.
- Required:
- I. Prepare a contribution format income statement that shows the expected net operating income each year from the franchise outlet. (9)
 - II. Compute the simple rate of return promised by the outlet. If Mr. Swanson requires a simple rate of return of at least 12%, should he acquire the franchise? (3)
 - III. Compute the payback period on the outlet. If Mr. Swanson wants a payback of four years or less, will he acquire the franchise? (3)
- (b) Describe the technology life cycle of a product. (10)
- (c) What is bottom-up budget? What are its merits and demerits? (10)

IPE 493

7. (a) Selected account balances for the year ended December 31 are provided below for Superior Company:

| | |
|---|-----------|
| Selling and administrative salaries | \$110,000 |
| Insurance, factory | \$8,000 |
| Utilities, factory | \$45,000 |
| Purchases of raw materials | \$290,000 |
| Indirect labor | \$60,000 |
| Direct labor | ? |
| Advertising expense | \$80,000 |
| Cleaning supplies, factory | \$7,000 |
| Sales commissions | \$50,000 |
| Rent, factory building | \$120,000 |
| Maintenance, factory | \$30,000 |

Inventory balances at the beginning and end of the year were as follows:

| | Beginning of the Year | End of the Year |
|-----------------------|--------------------------|--------------------|
| Raw materials | \$40,000 | \$10,000 |
| Work in process | ? | \$35,000 |
| Finished goods | \$50,000 | ? |

The total manufacturing costs for the year were \$683,000; the goods available for sale totaled \$740,000; and the cost of goods sold totaled \$660,000.

Required:

- I. Prepare a schedule of cost of goods manufactured and the cost of goods sold section of the company's income statement for the year. (12)
- II. Assume that the dollar amounts given above are for the equivalent of 40,000 units produced during the year. Compute the average cost per unit for direct materials used and the average cost per unit for rent on the factory building. (2)
- III. Assume that in the following year the company expected to produce 50,000 units. What average cost per unit and total cost would you expect to be incurred for direct materials? For rent on the factory building? (Assume that direct materials is a variable cost and that rent is a fixed cost.) (4)
- IV. As the manager in charge of production costs, explain to the president the reason for any difference in average cost per unit between (II) and (III) above. (2)

(b) Northwood Company manufactures basketballs. The company has a ball that sells for \$25. At present, the ball is manufactured in a small plant that relies heavily on direct labor workers. Thus, variable costs are high, totaling \$15 per ball. Last year, the company sold 30,000 of these balls, with the following results:

| | |
|------------------------------|------------------|
| Sales (30,000 balls) | \$750,000 |
| Less variable expenses | 450,000 |
| Contribution margin | 300,000 |
| Less fixed expenses | 210,000 |
| Net operating income | <u>\$ 90,000</u> |

IPE 493

Contd... Q. No. 7(b)

Required:

- I. Compute (a) the CM ratio and the break-even point in balls, and (b) the degree of operating leverage at last year's sales level. (5)
 - II. Due to an increase in labor rates, the company estimates that variable costs will increase by \$3 per ball next year. If this change takes place and the selling price per ball remains constant at \$25, what will be the new CM ratio and break-even point in balls? (5)
 - III. Refer to the original data. The company is discussing the construction of a new, automated manufacturing plant. The new plant would slash variable costs per ball by 40%, but it would cause fixed costs per year to double. If the new plant is built, what would be the company's new CM ratio and new break-even point in balls? (5)
8. (a) What are the steps of power delegation? Describe. (12)
- (b) Discuss the expectancy theory of motivation. (12)
- (c) Explain Gantt plan. How is it different from Taylor's plan and Halsey's plan? (11)
-

SECTION – A

There are **FOUR** questions in this Section. Answer any **THREE**.

Make reasonable assumptions on any missing data. Answer in brief and to the point.

1. (a) Why is line coding essential in digital communication systems? Name three line coding schemes with self-clocking feature and discuss their relative merits and demerits. (4+7)
- (b) The message signal $m(t)$ of a 3-bit PCM system with μ -law ($\mu = 100$) based non-uniform quantization is shown in Fig. for Q. No. 1. The quantizer is symmetric mid-rise type and uses rounding operation. The sampling frequency is 2.5 kHz and the first sample is taken at $t = 0.2$ ms. Calculate – (14)
- (i) the quantization errors for the first 4 samples,
- (ii) the quantization errors if uniform quantization were used and compare them with those in part (i).

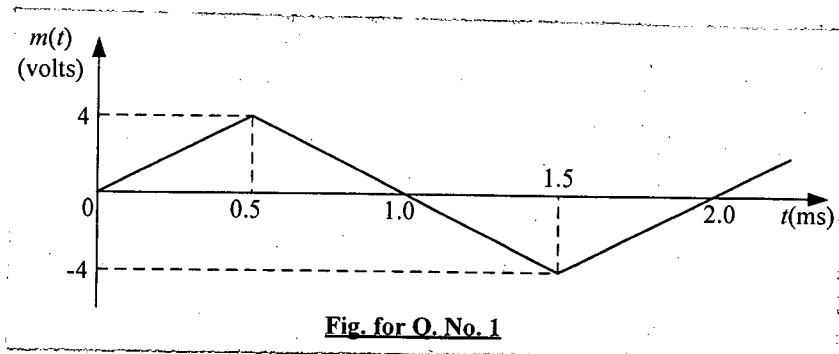

- (c) What are the basic differences between DPCM and DM? A DM system with a message signal $m(t)$ as shown in Fig. for Q. No. 1 uses a sampling frequency equal to 10 kHz. Calculate – (4+6)
- (i) the bit rate of the system,
- (ii) the minimum step size for avoiding slope overload noise.

2. (a) Consider a PCM system with a sinusoidal message signal $m(t)$ having values in the range $[-4, 4]$ volts and power equal to 10 W. Message bandwidth is 4 kHz and the sampling frequency is 150% higher than the Nyquist rate. The system uses uniform mid-rise types symmetric quantization, (13)

EEE 309

Contd ... Q. No. 2(a)

- (i) Calculate the required bit rate to achieve an SQNR equal to 20 dB,
- (ii) If the sampling frequency is doubled, calculate the new SQNR,
- (iii) If DPCM is used with the same bit rate as in part (i) and the DPCM error signal lies in the range $[-0.5, 0.5]$ volts, calculate the SQNR in dB.

(b) Draw the block diagram of a flat-topped PAM transmitter and receiver showing the amplitude spectrum of the signals at each output of system, blocks. Explain why an equalizer is necessary in a PAM receiver. (8+4)

(c) Consider a BPSK system with phase $\pi/4$ for bit '1' and $\pi/2$ for bit '0'. Design and draw the block diagram of the BPSK transmitter and the receiver. The answer should include the decision criteria at the receiver. (10)

3. (a) Write short notes on- (10)

- (i) T-carrier system
- (ii) FH-CDMA system

(b) Consider a joint TDM-FDM system as shown in Fig. for Q. No. 3(b). The Bandwidth of each source is 4 kHz and the sampling frequency is twice that of Nyquist frequency. Source signals are digitized using 8-bit PCM system with A-law compression ($A = 100$). (17)

- (i) Calculate the bit rate at the marked points P_1 to P_6 .
- (ii) Calculate the TDMA frame durations and frame rates at point P_3 and P_5 .
- (iii) If the bandwidth requirement at point P_4 is 512 kHz, calculate the bandwidth requirement at point P_6 assuming a guard band equal to 20 kHz.

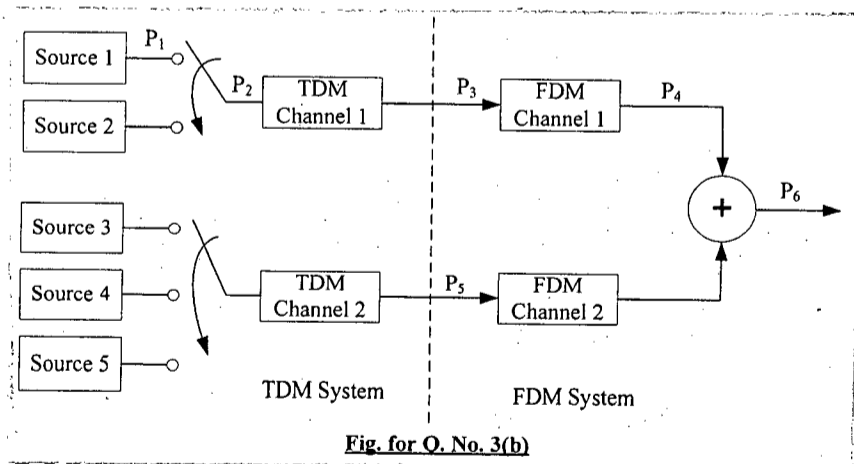

(c) With necessary diagram, explain the multiple access interference (MAI) in a multi-user DS-CDMA system. (8)

4. (a) Discuss the impact of increasing the order of digital modulations on the data rates, bandwidth, bit error rate (BER) and power requirement of a digital communication system. (10)

EEE 309

Contd ... Q. No. 4(a)

(b) A bit sequence [1 0 0 1 1 0 1 0] is to be transmitted using DPSK modulation with the encoding principle 'Bit 1 means a transition'. Assume the encoded reference bit is '0', phase '0' for bit '1' and phase ' π ' for bit '0'. (12)

(i) Design and draw the block diagram of the DPSK transmitter and the receiver.

(ii) Show the phase sequence of the transmitted DPSK signal.

(iii) If for some reasons, the received phase sequence is [$\pi \pi 0 0 \pi \pi 0 0$], Determine how many bits will be erroneously detected.

(c) Consider a DS-CDMA system with 3 transmitter-receiver pairs having PN sequence $C_1 = [0 0 0 0]$, $C_2 = [1 1 1 1]$ and $C_3 = [1 0 1 0]$ respectively. Each Transmitter has a data rate of 1 Mbps. (13)

(i) Determine whether the PN sequences are orthogonal to each other.

(ii) If the signal in the channel is [+1 -3 -3 -1 + 3 -1 -3 +1], determine the bit sequence detected by receiver 3.

(iii) Calculate the data rate and the chip rate of the DS-CDMA system.

(iv) If 2 bits can be transmitted using 1 Hz, calculate the bandwidth requirement of each transmitter and the complete DS-CDMA system.

SECTION – B

There are **FOUR** questions in this Section. Answer any **THREE**.

5. (a) What are the three major impairments in a communication channel? With appropriate sketches, explain how distortionless transmission can be achieved in a communication system ideally. Also mention how these impairments can be mitigated practically. (13)

(b) What are the sources of noise and interference in a communication system? Characterize the thermal noise and intermodulation noise.

The input $x(t)$ and the output $y(t)$ of a certain nonlinear channel is related as $y(t) = x(t) + 0.0025x^2(t)$. If $m(t) = 2\cos(1000\pi t) + \cos(2000\pi t)$, find the bandwidth of the output signal. Also determine the intrermodulation products. (12)

(c) The signal power at the input of an amplifier is 55 μ W. The amplifier has a gain of 50, internal noise power is 5 μ W and external noise power is 1 μ W. Calculate the noise figure in dB and the noise temperature of the amplifier. The room temperature is 27°C. Also find the application of the terms 'noise figure' and 'noise temperature' in communication systems. (10)

EEE 309

6. (a) Characterize the following communication channels and state their particular applications: STP cable and Fiber-optic cable. (10)
- (b) Using DSB-SC modulator as a major component, generate SSB and VSB modulated signals for a message signal of $m(t)$. (12)
- (c) An intelligence signal is $m(t) = 1.2\cos(400\pi t) + \cos(1000\pi t)$, if carrier signal is $C(t) = 2.4\cos(20000\pi t)$, derive the expression of DSB-SC signal showing the sidebands and determine the sideband power. Sketch the amplitude spectrum of DSB-SC signal and after suppressing the LSB spectrum, show the USB spectrum and find its expression in time domain. (13)
7. (a) (a) Write the differences between (10)
- (i) coherent and non-coherent demodulation processes and
- (ii) homodyne and heterodyne detection processes.
- (b) In case of coherent detection, if the phase or frequency of local oscillator output signal is different from input carrier's phase or frequency, what problems will occur? (12)
- (c) Why non-coherent detection can not be used for DSB-SC signal? 'SSB modulation is suitable for voice communication however VSB modulation is suitable for TV signals', Explain.
- Mathematically show that SSB + C can be detected non-coherently for a large carrier signal. (13)
8. (a) What are the merits and demerits of an angle modulated signal compared to an amplitude modulated signal. Show that phase and frequency modulations are inseparable. For a message signal $m(t) = 4\cos(100\pi t) + 20\cos(2000\pi t)$, write the expression of FM and PM signals when the carrier is given as $c(t) = 10\cos(2\pi \times 10^6 t)$, frequency sensitivity $k_f = 2000$ and phase sensitivity $k_p = 2\pi$. Also estimate the bandwidth of FM and PM signals. (15)
- (b) For a sinusoidal single-tone modulation, show that the bandwidth of the angle modulated signal is infinite. (10)
- (c) With block diagrams briefly explain the operation on an FM transmitter and a superheterodyne FM radio receiver. (10)
-

SECTION – A

There are **FOUR** questions in this section. Answer any **THREE**.

Symbols bear their usual meanings.

1. (a) Consider the following difference equation (18)

$$y[n] - 7y[n-1] + 10y[n-2] = 2x[n] + 5x[n-1]$$

Determine the step response of the system which is described by the above difference

equation. Consider $y[-1] = \frac{14}{5}$, $y[-2] = \frac{49}{25}$.

- (b) Using convolution sum property find $y[n]$ when (17)

$$x[n] = 2\delta[n+1] + \delta[n] + 2\delta[n-2]$$

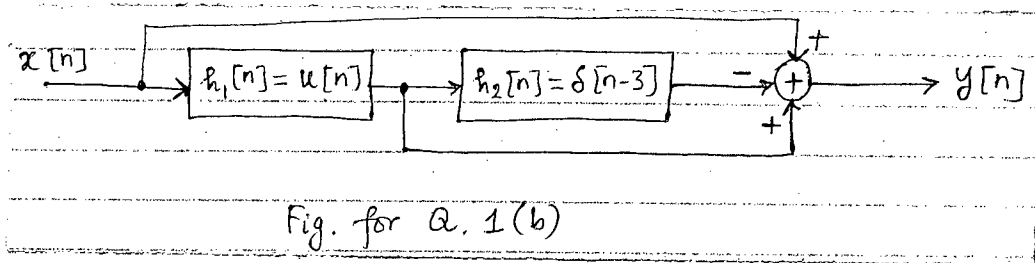

2. (a) An LTI system is described by the following input-output relationship (20)

$$y[n] = x[n] + 2x[n-1] + x[n-2]$$

Find (i) $H(e^{j\omega})$; (ii) Group delay (iii) Sketch the magnitude and phase of the frequency

response. (iv) Find $y[n]$ when $x[n] = \cos\left(\frac{\pi n}{3} + \frac{\pi}{6}\right)$.

- (b) For $x[n] = 2^n u[n-4]$ find $X(e^{j\omega})$.

If $S(e^{j\omega}) = X(e^{j(\omega+\pi)})$, find $\delta[n]$. (15)

3. (a) An LTI system has the following system transfer function (20)

$$H(z) = \frac{1 + z^{-1}}{\left(1 - \frac{1}{2}z^{-1}\right)\left(1 + \frac{1}{4}z^{-1}\right)}$$

(i) Find $h[n]$ considering stable and causal system.

(ii) Find the z-transform $X(z)$ of an input $x[n]$ that will produce the following output:

$$y[n] = -\frac{1}{3}\left(-\frac{1}{4}\right)^n u[n] - \frac{4}{3}2^n u[-n-1]$$

EEE 311

Contd ... Q. No. 3

(b) The pole-zero diagram shown in Fig. for Q. No. 3(b) corresponds to the z-transform $X(z)$ of a causal sequence $x[n]$. Sketch the pole-zero diagram of $Y(z)$, where $y[n] = x[-n + 3]$. Specify the region of convergence for $Y(z)$. (15)

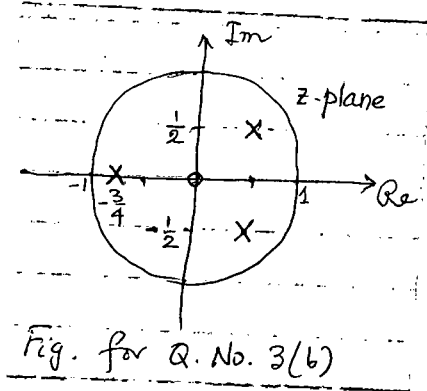

4. (a)

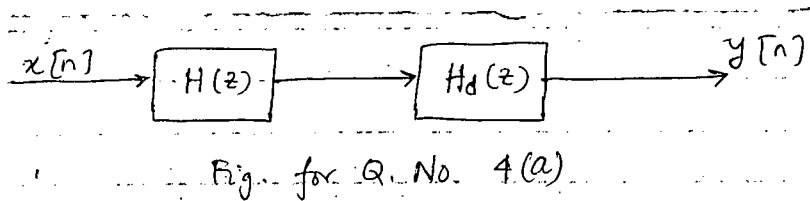

For the above system, given that $H(z)$ is causal, stable but non-minimum phase and $C(z)$ associated with $H(z)$ is given by (17)

$$C(z) = H(z)H^*\left(\frac{1}{z^*}\right) = \frac{(1+2z^{-1})(1+2z)}{(1-p_1z^{-1})(1-p_2z^{-1})(1-p_3z)(1-p_4z)}$$

where $p_1 = \frac{3}{4}e^{j\pi/3}$; $p_2 = p_1^*$;

$p_3 = p_1^*$; $p_4 = p_2^*$

How should $H_d(z)$ be chosen so that it is stable and causal and so that the magnitude of the overall effective frequency response is unity.

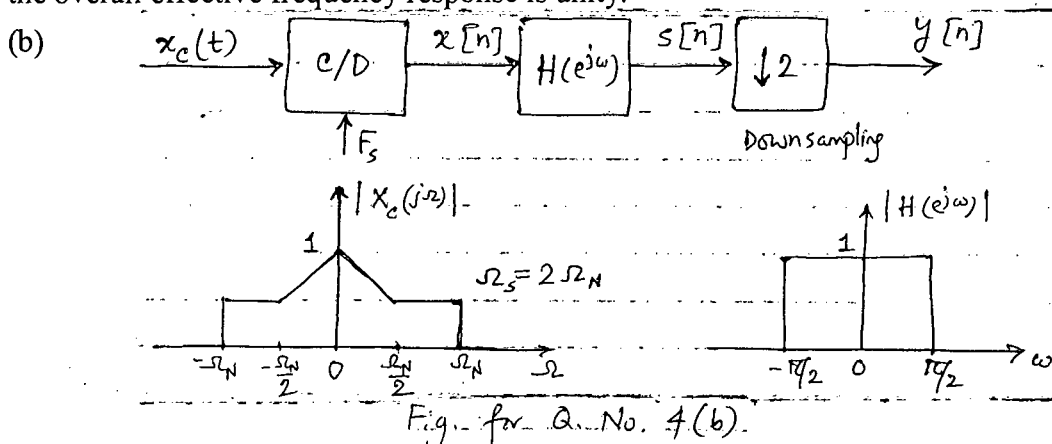

In the system shown in Fig. for Q. No. 4(b), discrete-time signal $x[n]$ is obtained from continuous time signal $x_c(t)$ that follows magnitude spectrum shown in the figure. $s[n]$ is obtained by filtering $x[n]$ using a discrete-time filter with magnitude spectrum shown in the figure. Finally $y[n]$ is obtained by downsampling $s[n]$ with a factor 2. Sketch (i) $|X(e^{j\omega})|$, (ii) $|S(e^{j\omega})|$ and (iii) $Y(e^{j\omega})$. (18)

EEE 311

SECTION – B

There are **FOUR** questions in this section. Answer any **THREE**.

5. (a) Consider the sequences (12)

$$x_1(n) = \{1, 2, 3, 4\} \quad \text{and} \quad s(n) = \{1, 0, 0, 0\}$$

\uparrow \uparrow

Determine the sequence $x_2(n)$ such that

$$s(k) = X_1(k) X_2(k)$$

where $s(k)$, $X_1(k)$ and $X_2(k)$ are 4-point DFTs.

- (b) Determine the Fourier transform $X(\omega)$ of the signal (12)

$$x(n) = \{1, 2, 3, 2, 1, 0\}$$

\uparrow

Using the expression of $X(\omega)$, compute the 6-point DFT $V(k)$ of the signal

$$u(n) = \{3, 2, 1, 0, 1, 2\}$$

\uparrow

- (c) Explain briefly how filtering of long data sequences is performed using 'overlap-save' method. (11)

6. (a) Why does spectral leakage occur during frequency analysis using the DFT? How can you reduce spectral leakage? (12)

(b) Consider $x_a(t)$ be an analog signal with bandwidth $B = 3$ KHz. You need to do an $N = 2^m$ point DFT of the signal with a resolution less than or equal to 50 Hz. Determine

- (i) the minimum sampling rate, and (ii) the minimum number of required samples. (12)

- (c) Obtain the direct form II realization for the system given by (11)

$$y(n) = \frac{3}{4} y(n-1) - \frac{1}{8} y(n-2) + x(n) + \frac{1}{3} x(n-1)$$

7. (a) The impulse response of an FIR filter is given by (10)

$$h(n) = \{0.5, 1, 1, 0.5\}$$

\uparrow

Explain why the filter with the given impulse response is unsuitable as a highpass filter.

- (b) A highpass FIR filter is characterized by the following impulse response coefficients: (10)

$$h(n) = \{0.127, -0.026, -0.237, 0.017, 0.434\}$$

\uparrow

Write down the coefficients of an equivalent lowpass filter with the aid of "frequency shifting" property of the Fourier transform.

- (c) Obtain the first three coefficients of an FIR lowpass filter that meets the following specification using the window method. (15)

passband edge freq : 1.5 kHz
 transition width : 0.5 kHz
 stopband attenuation : > 50 dB
 sampling frequency : 8 kHz

EEE 311

8. (a) In a certain signal processing application, the input signal is contaminated by a 50 Hz component and its harmonic at 150 Hz. The signal is sampled at 500 Hz. Find the transfer function of a simple digital filter to remove the interference and its harmonic. **(10)**

(b) Determine using the impulse invariant method, the transfer function of the digital equivalent of a resistive-capacitive (RC) lowpass filter. Assume a sampling frequency of 150 Hz and a cutoff frequency of 30 Hz. **(10)**

(c) A digital filter is required to remove baseline wander and artefacts due to body movement in a certain biomedical application. The filter is required to meet the following requirements: **(15)**

passband : 1 – 128 Hz

stopband : 0 – 0.5 Hz

passband ripple : 3 dB

stopband attenuation : 20 dB

sampling frequency : 256 Hz

Determine the order of a suitable IIR filter and its transfer function $H(z)$. The transfer function of prototype lowpass filter is given by

$$\text{order 1 : } H(s) = \frac{1}{s+1}$$

$$\text{order 2 : } H(s) = \frac{1}{s^2 + \sqrt{2}s + 1}$$

$$\text{order 3 : } H(s) = \frac{1}{(s+1)(s^2 + s + 1)}$$

BANGLADESH UNIVERSITY OF ENGINEERING AND TECHNOLOGY, DHAKA

L-3/T-2 B. Sc. Engineering Examinations 2013-2014

Sub : **EEE 315** (Microprocessor and Interfacing)

Full Marks: 210

Time : 3 Hours

USE SEPARATE SCRIPTS FOR EACH SECTION

The figures in the margin indicate full marks.

SECTION – AThere are **FOUR** questions in this section. Answer any **THREE**.

Assume reasonable data if necessary. Symbols used have their usual meanings.

Provide necessary comments in assembly language codes.

1. (a) Explain in details how an 8086 microprocessor manages to read data from or write data to a memory with a single read/write cycle. At which condition, does it fail to do so? What can a programmer do to circumvent that condition? (25)
- (b) Why does an 8086 microprocessor behave in a different way when an interrupt occurs at its INTR input? Explain its response with suitable diagram(s). (10)
2. (a) Show how a hex keyboard can be interfaced in a 8086 based system with proper schematic. Also explain the polling method of keyboard interfacing with a suitable flowchart. (15)
- (b) Draw the internal block diagram of an 8259A PIC and explain how it functions. Provide suitable examples. (20)
3. Consider an 8086 microprocessor based system in which eight LEDs are connected to PORTB of an 8255A PPI with base address 28H. Nothing else is connected with this PPI. The odd LEDs and the even LEDs are to be turned on alternatively. (35)
 - (a) Write an assembly language code to perform the task.
 - (b) Also write a C language code for the same task.
 - (c) Based on the experiences gained from writing codes for the given task, discuss advantages and disadvantages for both assembly language and high level language.
4. (a) Describe the asynchronous bit format used for serial data communication. (5)
- (b) Explain simplex, half-duplex and duplex serial data system with suitable examples. (5)
- (c) Suppose that you are asked to design an 8086 microprocessor based system, which will serve as a real time clock (RTC). Draw the schematic with necessary components (you do not need to show in detail how 8086 buses are obtained.) For display purpose, use CA type SSDs. Write a procedure named INIT_ICs which will initialize the ICs

EEE 315

Contd... Q. No. 4(c)

required. Also write an ISR named RTC_INT which will update the second, minute and hour variables of the RTC. Choose base addresses from the range FF00H-FFFFH. (25)

8259A PIC Control Words:

| | A0 | D7 | D6 | D5 | D4 | D3 | D2 | D1 | D0 |
|-------------|----|--------|--------|--------|--------|--------|-----|------|-----|
| ICW1 | 0 | A7 | A6 | A5 | 1 | LTIM | ADI | SNGL | IC4 |
| ICW2 | 1 | A15/T7 | A14/T6 | A13/T5 | A12/T4 | A11/T3 | A10 | A9 | A8 |
| ICW3 Master | 1 | S7 | S6 | S5 | S4 | S3 | S2 | S1 | S0 |
| ICW3 Slave | 1 | 0 | 0 | 0 | 0 | 0 | ID2 | ID1 | ID0 |
| ICW4 | 1 | 0 | 0 | 0 | SFNM | BUF | M/S | AEOI | μPM |
| OCW1 | 1 | M7 | M6 | M5 | M4 | M3 | M2 | M1 | M0 |
| OCW2 | 0 | R | SL | EOI | 0 | 0 | L2 | L1 | L0 |

8254 Control Word:

| D7 | D6 | D5 | D4 | D3 | D2 | D1 | D0 |
|-----|-----|-----|-----|----|----|----|-----|
| SC1 | SC0 | RW1 | RW0 | M2 | M1 | M0 | BCD |

8255A PPI Mode Set Control Word:

| D7 | D6 | D5 | D4 | D3 | D2 | D1 | D0 |
|---------------|------------|----|-----------|---------------|------------|-----------|---------------|
| Mode set Flag | PORTA MODE | | PORTA I/O | PORTC (U) I/O | PORTB MODE | PORTB I/O | PORTC (L) I/O |

8255A PPI Bit Set/Reset Control Word:

| D7 | D6 | D5 | D4 | D3 | D2 | D1 | D0 |
|--------------------|----|----|----|----|----|----|-----------|
| Bit set/reset Flag | X | X | X | B2 | B1 | B0 | Set/Reset |

SECTION – B

There are **FOUR** questions in this section. Answer any **THREE**.

5. (a) Write an assembly program to count the number of vowels in a 20 byte long string. (15)

(b) What is the significance of a high overflow flag after an IMUL operation? What will be the content of AX, DX and OF after the execution of following code snippet? (10)

```
MOV AX, 1
MOV BX, -3
IMUL BX
```

(c) Explain why a certain physical address in 8086 can have multiple segment addresses. A memory location has a physical address 80FD2H. In what segment does it have offset 95A2H? (10)

EEE 315

6. (a) Write an assembly program which most efficiently transposes a 3×3 matrix. A is the transpose of B if the rows of A are Columns in B. Declare both these matrices in row-major format. (20)

(b) Execute the following code snippet line by line and after executing each line, determine the states of the status flags (excluding AF). (10)

```
MOV AX, 0DDDDH
MOV BX, 0EEEEH
ADD AX, BX
ROR AX
NEG BX
```

(c) Why is it important to latch the contents of 8086 address bus? (5)

7. (a) The byte type coordinates of two points on the Cartesian plane is saved in two arrays. Write an assembly program to calculate the distance between them. You only need to find the integer part of the result. For (2,0) and (5,-3), result should be 4. (18)

(b) Determine the function of the following code snippet. Replace it with a faster alternative code. (12)

```
MOV CX, 11
MOV AH, 200
XOR AL, AL
CMP AH, CL
JL EXIT_
Loop1: SUB AH, CL
INC AL
CMP AH, CL
JL EXIT_
Loop Loop1
EXIT_: HLT
```

(c) What are the basic elements of a computer system? (5)

8. (a) Briefly describe the write cycle in an 8086 based microcomputer. (15)

(b) Rewrite the following code snippet replacing 'Loop' with conditional jump. (7)

```
MOV CX, 10
LOOPADD:
ADD AX, CX
LOOP LOOPADD
```

EEE 315

Contd... Q. No. 8

(c) Determine the syntax errors in the following assembly program. Rewrite it correctly.

(13)

CODE SEGMENT

ASSUME CS: CODE, DS: CODE

MOV AX, CS

MOV DS, AX

MOV AX, ABCDH

PUSH AX

MOV A, B

ADD A, AX

POP AL

MOV CL, B

LOOP.?:

SUB AX, CL

LOOP LOOP.?

HLT

SECTION – A

There are **FOUR** questions in this section. Answer any **THREE**.

1. (a) Derive an expression for inductance of a single phase composite conductor transmission line in terms of GMD and GMR. (15)
- (b) Six conductors of ACSR Drake constitute a 60-Hz double circuit three phase line arranged as shown in Fig. for Q. No. 1(b). Find (i) the inductance per phase (in H/mi) and the inductive reactance (in Ω /mi) (ii) the capacitive reactance to neutral (in Ω -mi) and the charging current in A/mi per phase and per conductor at 132 kV. (20)

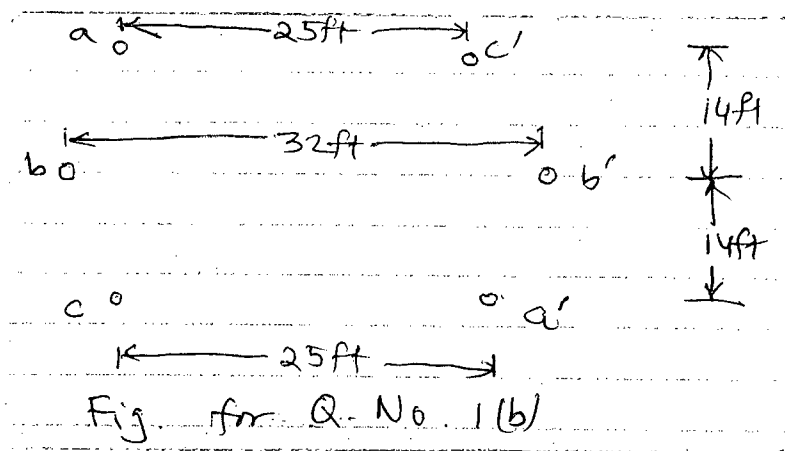

2. (a) Derive an expression for the capacitance of three phase transmission lines considering the effect of earth. (17)
- (b) A three-phase 50 Hz line has flat horizontal spacing. The conductors have an outside diameter of 3.28 cm with 12 m between conductors. (18)
 - (i) Determine the capacitive reactance to neutral in ohm-meters and the capacitive reactance of the line in ohms if its length is 125 mi.
 - (ii) Determine the same as in (i) but take into account the effect of ground. Assume that the conductors are horizontally placed 20 m above ground.

3. (a) A 250-Kcmil, single conductor, synthetic rubber, belted cable has a conductor diameter of 0.575 in and inside diameter of sheath of 1.235 in. The cable has a length of 6000 ft and is going to be used at 50 Hz and 132 kV. Calculate the following: (11)
 - (i) total insulation resistance in $M\Omega$
 - (ii) power loss due to leakage current flowing through insulation resistance.

The resistivity of insulation of synthetic rubber is $1.965 \times 10^{11} \Omega$ -ft.

EEE 371

Contd... Q. No. 3

- (b) Explain how capacitance between conductors (C_c) and that between conductor and sheath (C_s) can be calculated through various methods. (14)
- (c) Explain how location of fault in an underground cable is determined by using Murray loop test. (10)
- 4. (a) Show the typical circuit arrangement of high voltage DC transmission for (10)
 - (i) monopolar arrangement and
 - (ii) bipolar arrangement
- (b) The total power transmission capability of a bipolar DC system and a 3-phase 3-wire AC system are same. The two systems have same thermal unit, crest voltage, length and conductor size. Determine the power factor of the AC system. (15)
- (c) Write the major advantages and disadvantages of DC transmission over AC transmission. (10)

SECTION – B

There are **FOUR** questions in this section. Answer any **THREE**.

- 5. (a) With necessary figures explain the method of step-by-step solution of the swing curve for obtaining P_a , ω_r and δ . What are the assumptions in the solution? (11)
- (b) Consider the single line diagram shown in Fig. for Q. No. 5(b). All the impedances are in per unit. (14)

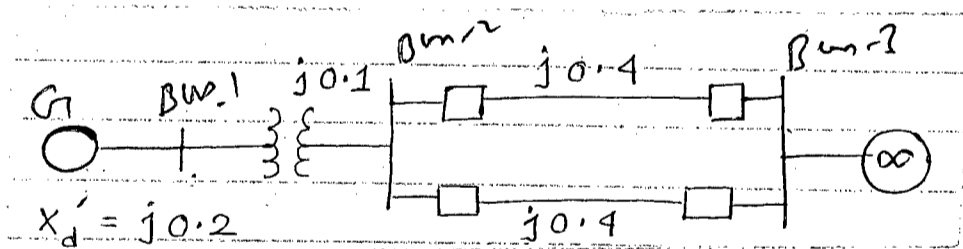

Fig for Q. No. 5 (b)

The generator is delivering 1 p.u. power and both the terminal voltage (Bus-1) and the infinite bus (Bus-3) voltages are 1.0 p.u. Determine,

- (i) the power angle equation of the system
- (ii) corresponding swing equation if $P_m = 1.0$ p.u.
- (iii) operating point of the system and
- (iv) the value of the synchronizing power coefficient at the operating point.
- (c) Derive the swing equation (10)
 - (i) for two coherently swinging machines at the same power plant
 - (ii) for two non-coherent machines.

EEE 371

6. (a) The power angle equations of a generator which was delivering P_m p.u. power to an infinite bus are as follows: (15)

Before the fault: $P_e = P_{max} \sin \delta$

During the fault: $P_e = r_1 P_{max} \sin \delta$

After the fault: $P_e = r_2 P_{max} \sin \delta$

Derive an expressions for the critical clearing angle using the given power angle equations.

- (b) In a one machine to an infinite bus system operating under steady state condition, $P_m = 1.0$ p.u. and $P_e = 2.10 \sin \delta$. A three phase fault occurs in the system and during the fault $r_1 P_{max} \sin \delta = 0.808 \sin \delta$. When the fault is cleared the system returns to the previous operating condition. Calculate the critical clearing angle and the critical clearing time for the system. Assume, $H = 5$ MJ/MVA. (10)

- (c) Explain how additional transmission lines and series capacitor compensation of lines improve transient stability. (10)

7. (a) Draw the topology of thyristor controlled reactor (TCR) and describe the main features of (i) 6-pulse topology and (ii) 12-pulse topology. (10)

- (b) Draw the VAR compensation topology implemented with a voltage source converter in STATCOM. Draw the associated vector diagrams in leading and lagging power factor. (15)

- (c) Draw the topology of unified power flow controller (UPFC). Describe its main features. (10)

8. (a) Determine the magnitude of voltage sag if the fault is at 11 kV and the PCC is at 33 kV. Use the following table: (10)

| Voltage level | Fault level |
|---------------|-------------|
| 400 V | 20 MVA |
| 11 kV | 200 MVA |
| 33 kV | 900 MVA |
| 132 kV | 3000 MVA |
| 400 kV | 17000 MVA |

EEE 371

Contd... Q. No. 8

(b) From the following table, calculate %TDD (Total Demand Distribution) if the fundamental component of load current, $I_L = 100$ A. (10)

| Harmonic Order | Individual current harmonic (A) |
|----------------|---------------------------------|
| 2 | 0.2 |
| 3 | 0.4 |
| 4 | 0.6 |
| 5 | 0.8 |

(c) For a critical voltage of 50%, determine the critical distance for fault at 11 kV. Use the following table: (15)

| Nominal voltage | Fault level | Feeder impedance |
|-----------------|-------------|------------------|
| 400 V | 20 MVA | 230 mΩ/km |
| 11 kV | 200 MVA | 310 mΩ/km |
| 33 kV | 900 MVA | 340 mΩ/km |
| 132 kV | 3000 MVA | 450 mΩ/km |
| 400 kV | 10000 MVA | 290 mΩ/km |

SECTION – A

There are **FOUR** questions in this section. Answer any **THREE**.

All the symbols and notations used in this section have their usual meanings.

1. (a) What are the key principles, concepts, techniques and challenges of analog IC design? Show in a chart how the analog design techniques evolved with time. (10)
- (b) Tabulate the analog IC design process. Also illustrate different types of resistors, capacitors and inductors on silicon substrate. (10)
- (c) Draw all the capacitances related to a MOSFET. Also calculate the source and drain junction capacitances of the two structures shown in the Fig. for Q. No. 1(c) (Answers need not to be in numeric forms). (15)

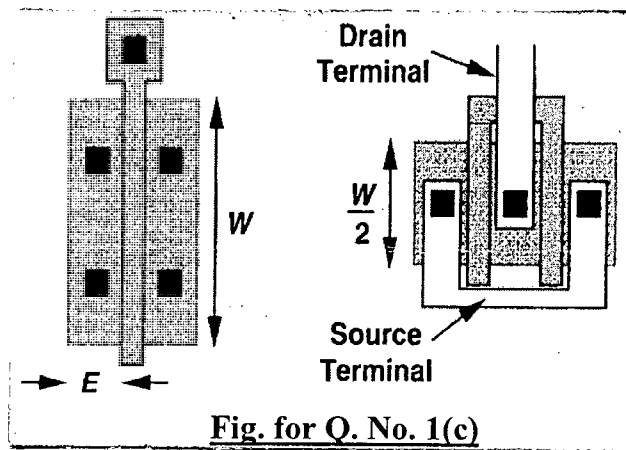

2. (a) What do you understand by a compact model? Draw the small-signal equivalent circuit of a short-channel MOSFET considering body effect. (10)
- (b) Calculate the voltage gain of the circuit shown in the Fig. for Q. No. 2(b). (10)

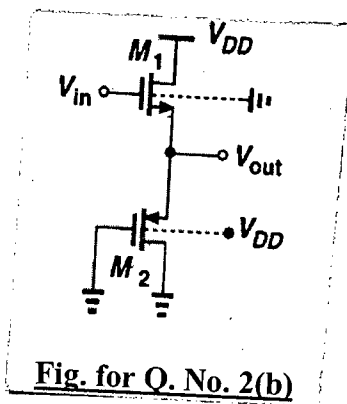

- (c) Define cascade stage of an amplifier. Calculate the transconductance and output impedance of the cascade stage with current-source load. (15)

EEE 351

3. (a) Identify the circuit shown in Fig. for Q. No. 3(a). Explain its operation both in the direct clock and in the complemented clock modes. (10)

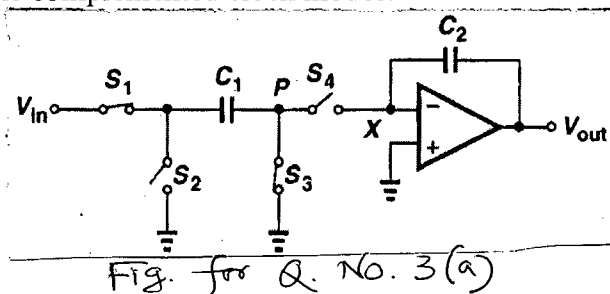

- (b) Discuss the similarities and differences between a unity-gain sampler and a non-inverting amplifier realized with switched capacitors. (10)
- (c) What are channel charge injection and clock feedthrough? Suggest remedies to eliminate their effects on switching. (15)
4. (a) Show the classification of CMOS Op-Amp. Draw the model for a non-ideal Op-Amp. (10)
- (b) Break up the classical two-stage CMOS Op-Amp into voltage-to-current and current-to-voltage stages. (10)
- (c) Describe the compensation schemes of Op-Amp. What will be the required phase margin for good stability? (15)

SECTION - B

There are **FOUR** questions in this section. Answer any **THREE**.

5. (a) Discuss the advantages of single ended operation over differential operation of an analog device. (8)
- (b) Draw the circuit diagram of a basic differential pair and calculate the gain. (12)
- (c) From the circuit of Fig. for Q. No. 5(c), derive the expression of common mode gain A_{CM-DM} . Then calculate the common mode rejection ratio, CMRR. Here, $g_{m1} \neq g_{m2}$. (15)

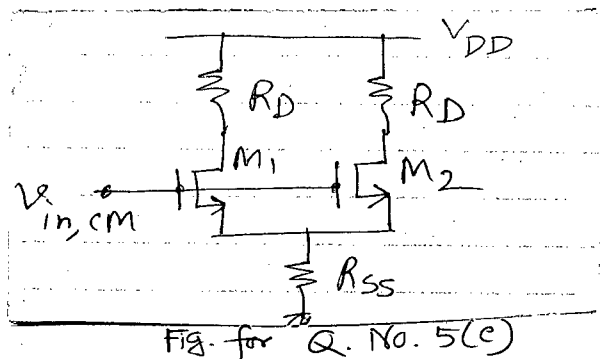

6. (a) What is VGA? Design a Gilbert cell showing different steps of design. (10)
- (b) What is cascode current mirror? Design a "low voltage cascode" and explain its biasing arrangement. (10)

EEE 351

Contd... Q. No. 6

- (c) Derive the expression of gain of the active current mirror shown in Fig. for Q. No. 6(c). (15)

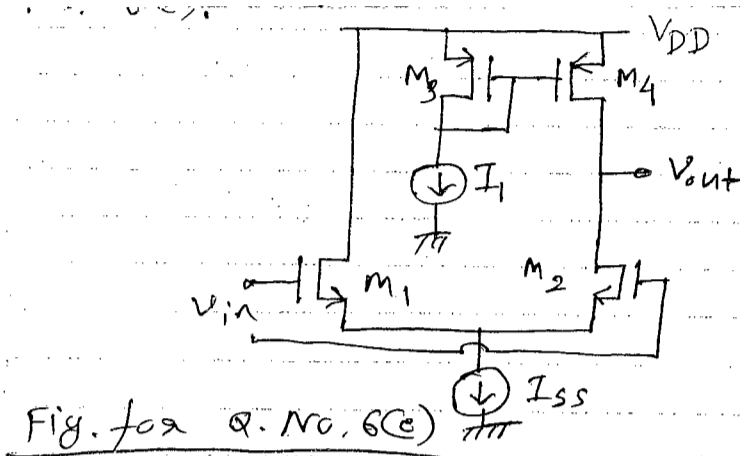

7. (a) Consider the RC circuit shown in Fig. for Q. No. 7(a). Calculate the noise spectrum and the total noise power in V_{out} . (13)

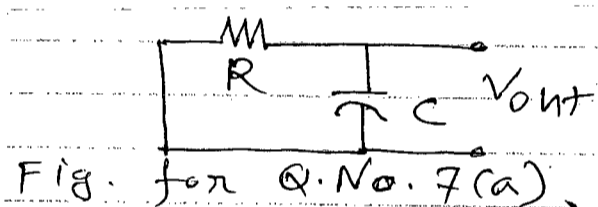

- (b) What is noise Bandwidth? Calculate the input referred and output referred noise voltage of a simple CS stage. (11)

- (c) Calculate the input referred noise voltage of a differential pair. (11)

8. (a) What is negative TC voltage? Prove, (10)

$$\frac{\partial V_{BE}}{\partial T} = \frac{V_{BE} - (4+m)V_T - \frac{E_s}{q}}{T}$$

where the symbols have their usual meanings.

- (b) What is positive TC voltage? Calculate ΔV_{BE} for the circuit of Fig. for Q. No. 8(b). (10)

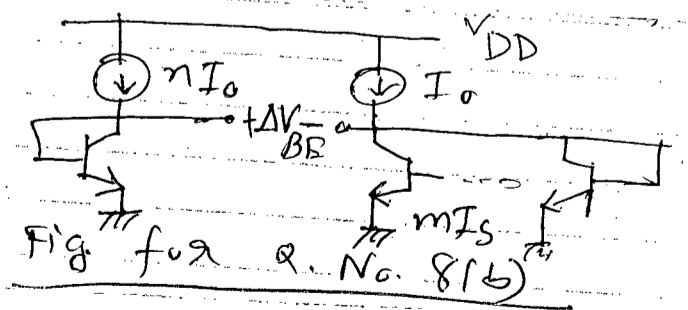

EEE 351

Contd... Q. No. 8

(c)

(15)

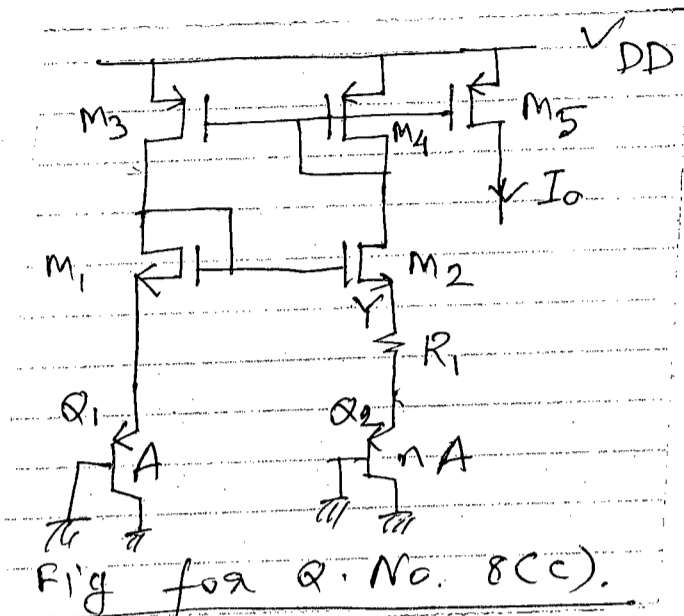

What is the characteristic of the current I_0 ? Analyze the circuit of Fig. for Q. No. 8(c) and explain the characteristic.

SECTION – A

There are **FOUR** questions in this section. Answer any **THREE**.

Table of Fourier Transform Pairs is attached.

1. (a) A random process $Y(t)$ is given by (20)

$$Y(t) = A \cos(\omega t + \phi)$$

where A , ω and ϕ are independent random variables, ϕ and ω are uniformly distributed between $-\pi$ and π and -6 and 6 , respectively. Also, $E(A) = 3$ and $\sigma_A^2 = 9$. Determine if $Y(t)$ is a wide-sense stationary (WSS) process or not. Next, find $S_{yy}(\omega)$. $Y(t)$ is sampled at $T_s = 20$ s to produce $Z(n)$. Find $S_{zz}(\Omega)$.

- (b) The random processes $X(t)$ and $Z(t)$ are given by (15)

$$X(t) = A \cos(\omega t + \theta)$$

$$Z(t) = B$$

where A and θ are independent random variables. Also, $E(A) = 3$ and $\sigma_A^2 = 9$, and the mean and variance of the random variable B are μ_B and σ_B^2 , respectively. Determine if the random processes $X(t)$ and $Z(t)$ are mean-ergodic.

2. (a) The input and output of the following LTI system are $X(t)$ and $Y(t)$, respectively. (20)

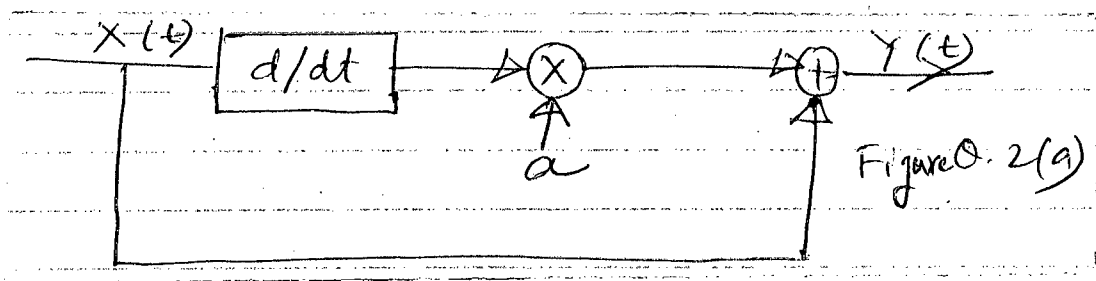

$X(t)$ is a random telegraph process with autocorrelation function

$$R_{XX}(\tau) = \sigma_X^2 e^{-2\pi|\tau|}$$

where $\sigma_X^2 = 5$. a is an arbitrary constant. Find (i) output power (ii) σ_Y^2 , and (iii) whether $Y(t)$ has an integral and derivative in the mean square sense (MSS).

EEE 331

Contd... Q. No. 2

(b) Explain why the following functions can or cannot be the power spectral density of a WSS random process and cross-power spectral density of two jointly WSS random processes. (15)

- (i) $S_{xx}(w) = \frac{4}{w^2 + 4w + 2}$, (ii) $S_{xx}(w) = \frac{5w^2}{j + 3w^2 + 4w^4}$
- (iii) $S_{xx}(w) = \frac{5w}{1 + 4w + 3w^4}$, (iv) $S_{xy}(w) = \frac{1}{-w^2 + j4w + 4}$
- (v) $S_{xy}(w) = \frac{9}{w^2 + 64}$

3. (a) The WSS random process X(t) is given by (20)

$$R_{XX}(T) = 4 \cdot (1/2)^{|T|} + 16(1/4)^{|T|}$$

The output of a RC circuit is Y(t) where the input to the circuit is X(t) as shown in Fig. for Q. 3(a). (20)

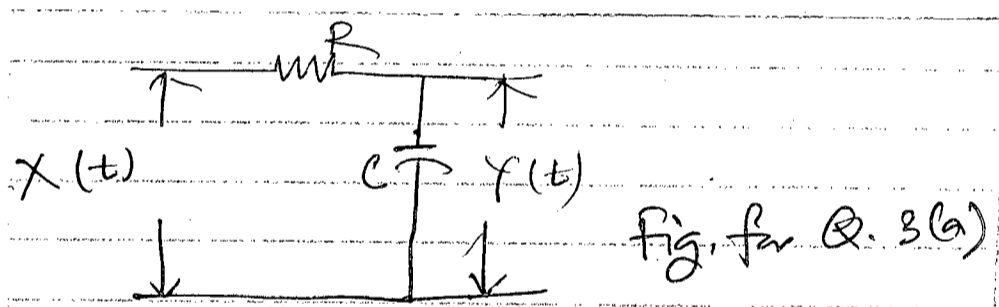

Find (i) $S_{XX}(w)$, (ii) $P_{XX}(\tau)$, (iii) $S_{XY}(w)$, (iv) $R_{XY}(\tau)$. Assume that the circuit is an LTI system.

(b) State and prove the Central Limit Theorem. (15)

4. (a) Two random variables X and Y are jointly Gaussian with $\mu_x = \mu_y = 0$, $\sigma_x^2 = \sigma_y^2$. The parameters of the joint Gaussian pdf are $\mu_x, \mu_y, \sigma_x^2, \sigma_y^2$ and $\rho_{X,Y}$. Using the joint pdf $f_{X,Y}(x,y)$ show that the random variables X and Y can be independent if they are uncorrelated. (20)

(b) For the two networks shown in Figs. Q. 4(b) (i) and Q. 4(b)(ii), determine the reliabilities of the two networks. Assume that the components of the networks fail independently. Also, each of the components has identical reliability of 0.99.

EEE 331

Contd... Q. No. 4(b)

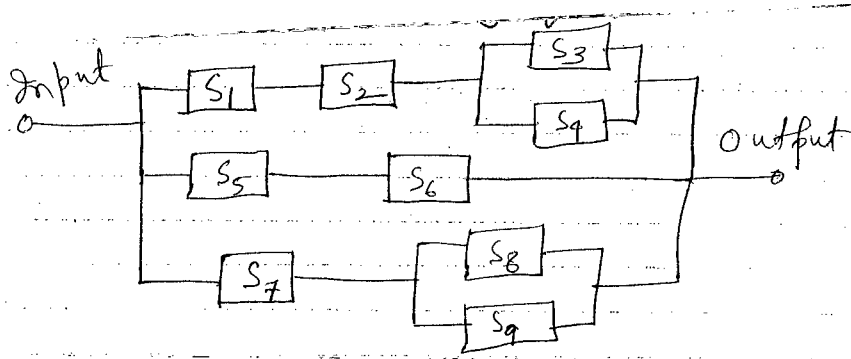

Fig. for Q. 4(b) (i)

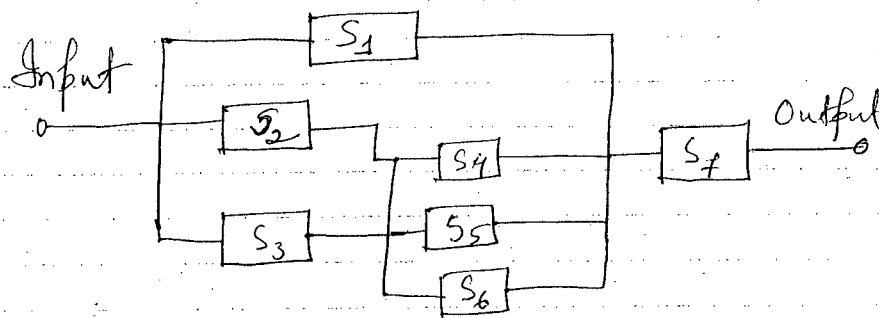

Fig. for Q. 4(b) (ii)

SECTION - B

There are **FOUR** questions in this section. Answer any **THREE**.

5. (a) A company sells high fidelity amplifiers capable of generating 10, 25, and 50 W of audio power. It has on hand 100 of the 10-W units, of which 15% are defective, 70 of the 25-W units with 10% defective, and 30 of the 50-W units with 10% defective. (18)

- (i) What is the probability that an amplifier sold from the 10-W units is defective?
- (ii) If each wattage amplifier sells with equal likelihood, what is the probability of a randomly selected unit being 50 W and defective?
- (iii) What is the probability that a unit randomly selected for sale is defective?

(b) A missile can be accidentally launched if two relays A and B both have failed. The probabilities of A and B failing are known to be 0.01 and 0.03, respectively. It is also known that B is more likely to fail (probability 0.06) if A has failed.

- (i) What is probability of an accidental missile launch?
- (ii) What is the probability that A will fail if B has failed?
- (iii) Are the events "A fails" and "B fails" statistically independent? (17)

EEE 331

6. (a) A rifleman can achieve a "marksman" award if he passes a test. He is allowed to fire six shots at a target's bull's eye. If he hits the bull's eye with at least five of his six shots he wins a set. He becomes a marksman only if he can repeat the feat three times straight, that is, if he can win three straight sets. If his probability is 0.8 of hitting a bull's eye on any one shot, find the probabilities of his: (18)

- (i) winning a set, and
- (ii) becoming a marksman.

- (b) Consider the following table- (17)

Table 1: Numbers of colored balls in two boxes

| (Event) x_i | Ball color | Box | | Total |
|---------------|------------|------------|------------|------------|
| | | 1 | 2 | |
| x_1 | Red | 5 | 80 | 85 |
| x_2 | Green | 35 | 60 | 95 |
| x_3 | Blue | 60 | 10 | 70 |
| Totals | | 100 | 150 | 250 |

Now define a discrete random variable X to have values x_1, x_2, x_3 when a red, green or blue ball is selected from any of the two boxes. Compute probability mass function of X . Draw probability density and distribution functions. [Given probabilities of selecting Box 1 and Box 2 are $\frac{1}{5}$ and $\frac{4}{5}$, respectively.]

7. (a) A random variable X has a probability density function (15)

$$f_X(x) = \begin{cases} \left(\frac{5}{4}\right)(1-x^4) & 0 < x \leq 1 \\ 0, & \text{otherwise} \end{cases}$$

Find (i) $E[X]$ (ii) $E[4X+2]$ (iii) $E[X^2]$ (iv) σ_X^2

- (b) A random variable X is uniformly distributed in $(0, 6)$. If X is transformed to a new random variable $Y = 2(X-3)^2 - 4$, find (i) $f_Y(y)$ (ii) $E[Y]$ (iii) σ_Y^2 . (20)

8. (a) A random variable X has the distribution function (15)

$$F_X(x) = \sum_{n=1}^{12} \frac{n^2}{650} u(x-n).$$

Find the probabilities (i) $P(-\infty < X \leq 6.5)$ (ii) $P(X > 4)$ (iii) $P(6 < X \leq 9)$.

- (b) Let $X \sim U(0, 1)$, $Y \sim U(0, 1)$. Suppose X and Y are independent. Define $Z = X + Y$ $W = X - Y$. Show that Z and W are not independent, but uncorrelated random variables. (20)

Table E.1 Common Fourier Transform Pairs

| Signal (time domain) | Transform (frequency domain) |
|--|--|
| $\text{rect}(t/t_0)$ | $t_0 \text{sinc}(ft_0)$ |
| $\text{tri}(t/t_0)$ | $t_0 \text{sinc}^2(ft_0)$ |
| $\exp\left(-\frac{t}{t_0}\right) u(t)$ | $\frac{t_0}{1 + j2\pi ft_0}$ |
| $\exp\left(-\frac{ t }{t_0}\right)$ | $\frac{2t_0}{1 + (2\pi ft_0)^2}$ |
| $\text{sinc}(t/t_0)$ | $t_0 \text{rect}(ft_0)$ |
| $\text{sinc}^2(t/t_0)$ | $t_0 \text{tri}(ft_0)$ |
| $\exp(j2\pi f_0 t)$ | $\delta(f - f_0)$ |
| $\cos(2\pi f_0 t + \theta)$ | $\frac{1}{2} \delta(f - f_0) e^{j\theta} + \frac{1}{2} \delta(f + f_0) e^{-j\theta}$ |
| $\delta(t - t_0)$ | $\exp(-j2\pi ft_0)$ |
| $\text{sgn}(t)$ | $\frac{1}{j\pi f}$ |
| $u(t)$ | $\frac{1}{2} \delta(f) + \frac{1}{j2\pi f}$ |
| $\exp(-(t/t_0)^2)$ | $\sqrt{\pi t_0^2} \exp(-(\pi ft_0)^2)$ |