

BANGLADESH UNIVERSITY OF ENGINEERING AND TECHNOLOGY, DHAKA

L-1/T-2 B. Sc. Engineering Examinations 2014-2015

Sub : **MATH 193** (Vector, Matrices and Coordinate Geometry)

Full Marks : 280

Time : 3 Hours

The figures in the margin indicate full marks.

Symbols have their usual meaning.

USE SEPARATE SCRIPTS FOR EACH SECTION

**SECTION – A**There are **FOUR** questions in this Section. Answer any **THREE**.

1. (a) Determine whether the vectors  $\underline{u} = (1, -1, 0)$ ,  $\underline{v} = (5, 3, -2)$ ,  $\underline{w} = (1, 3, -1)$  are linearly independent. If not, then find a relation among them. Also determine whether the terminal points are collinear. (22  $\frac{2}{3}$ )
- (b) Use vectors to find an equation for the plane determined by the points P(2, -1, 1), Q(3, 2, -1) and R(-1, 3, 2). (12)
- (c) Give the geometrical interpretation of scalar triple product of vectors  $\mathbf{A} \cdot (\mathbf{B} \times \mathbf{C})$  and show in figure. (12)
2. (a) For three vectors  $\mathbf{A}$ ,  $\mathbf{B}$ ,  $\mathbf{C}$ , derive a formula for  $\mathbf{A} \times (\mathbf{B} \times \mathbf{C})$  and then prove that  $\mathbf{A} \times (\mathbf{B} \times \mathbf{C}) + \mathbf{B} \times (\mathbf{C} \times \mathbf{A}) + \mathbf{C} \times (\mathbf{A} \times \mathbf{B}) = \mathbf{0}$ . (23)
- (b) If  $\underline{a}'$ ,  $\underline{b}'$ ,  $\underline{c}'$  are reciprocal vectors of  $\underline{a}$ ,  $\underline{b}$ ,  $\underline{c}$  then show that any vector  $\underline{r}$  can be expressed as  $\underline{r} = (\underline{r} \cdot \underline{a}')\underline{a} + (\underline{r} \cdot \underline{b}')\underline{b} + (\underline{r} \cdot \underline{c}')\underline{c}$ . (23  $\frac{2}{3}$ )
3. (a) Find the inverse of the matrix  $\mathbf{A} = \begin{pmatrix} 1 & 3 & 3 \\ 1 & 4 & 3 \\ 1 & 3 & 4 \end{pmatrix}$  using (i) adjoint method and (ii) elementary row operations. (23  $\frac{2}{3}$ )
- (b) Reduce the matrix  $\mathbf{A} = \begin{pmatrix} 1 & 2 & -1 & 2 \\ 3 & 1 & -2 & -1 \\ 4 & -3 & 1 & 1 \end{pmatrix}$  to the normal form B and obtain the non-singular matrices P and Q such that  $\mathbf{PAQ} = \mathbf{B}$ . (23)
4. (a) Reduce the quadratic form  $q = X'AX = x^2 + 7y^2 + 8z^2 - 6xy + 4xz - 10yz$  to the canonical form. Write down the transformation matrix P, equivalent diagonal matrix D and the rank, index and signature. (23)
- (b) Find the eigen values, eigen vectors and eigen spaces of the matrix,  $\mathbf{A} = \begin{pmatrix} 0 & 0 & -2 \\ 1 & 2 & 1 \\ 1 & 0 & 3 \end{pmatrix}$ .
- Is the matrix A diagonalizable? Explain your reasoning. (23  $\frac{2}{3}$ )

**MATH 183****SECTION – B**

There are **FOUR** questions in this Section. Answer any **THREE**.

5. (a) Transform the equation  $17x^2 + 18xy - 7y^2 - 16x - 32y - 18 = 0$  to one in which there is no term involving  $x$ ,  $y$  and  $xy$  by suitable translation and rotation of axes. Also identify the conic. (23)
- (b) If  $l_1, m_1, n_1$ ;  $l_2, m_2, n_2$  and  $l_3, m_3, n_3$  be the direction cosines of three mutually perpendicular lines, then find the direction cosines of the line whose direction ratios are  $l_1 + l_2 + l_3, m_1 + m_2 + m_3, n_1 + n_2 + n_3$ . Also show that this line is equally inclined to the given lines. (23  $\frac{2}{3}$ )
6. (a) Find the equation of the plane through the intersection of the planes  $x + 2y + 3z + 4 = 0$  and  $4x + 3y + 2z + 1 = 0$  and perpendicular to the plane  $x + y + z + 9 = 0$  and show that it is perpendicular to the  $xz$  plane. (15)
- (b) A variable plane is at a constant distance  $p$  from the origin and meets the axes in A, B, C. Show that the locus of the centroid of the tetrahedron OABC is  $x^{-2} + y^{-2} + z^{-2} = p^{-2}$  where O is the origin. (15)
- (c) Determine the constant  $k$  so that the planes  $x - 2y + kz = 0$  and  $2x + 5y - z = 0$  are at right angles and find, in that case, the plane through the point  $(1, -1, -1)$  and perpendicular to both the given planes. (16  $\frac{2}{3}$ )
7. (a) Show that the lines  $\frac{x-5}{4} = \frac{y-7}{4} = \frac{z+3}{-5}$  and  $\frac{x-8}{7} = \frac{y-4}{1} = \frac{z-5}{3}$  are coplanar; find their common point and the equation of the plane in which they lie. (23)
- (b) Find the shortest distance between the line  $ax + by + cz + d = 0 = a_1x + b_1y + c_1z + d_1$  and the axis of  $x$ . (23  $\frac{2}{3}$ )
8. (a) Find the equation of the spheres which pass through the circle  $x^2 + y^2 + z^2 - 2x + 2y + 4z - 3 = 0, 2x + y + z = 4$  and touch the plane  $3x + 4y = 14$ . (23)
- (b) Find the equation of the tangent planes of the sphere  $x^2 + y^2 + z^2 - 4x + 2y = 4$  which are parallel to the plane  $2x - y + 2z = 1$  and also find the coordinates of the points of contact. (23  $\frac{2}{3}$ )

**SECTION – A**There are **FOUR** questions in this Section. Answer any **THREE**.

1. (a) Calculate the voltage at all nodes and current through all branches of the circuit of Fig. for Q. No. 1(a). (17)
- (b) Prove, for 3- $\phi$  Y-connection,  $V_L = \sqrt{3} V_P$ , where the symbols have their usual meanings. (12  $\frac{2}{3}$ )
- (c) A balanced 3- $\phi$  source supplies power to the following 3 loads:  
 Load 1: 6 kVA at 0.83 pf lagging  
 Load 2: unknown  
 Load 3: 8 kW at 0.7071 pf lagging
- If the line current is 84.6 A rms, the line voltage is 208 V rms, and the combined load has a 0.8 pf lagging, determine the unknown load. Also, calculate the value of capacitor or inductor to be connected in  $\Delta$  to make the pf unity. (17)
2. (a) For the BJT amplifier shown in Fig. for Q. No. 2(a), determine (i) Voltage gain, (ii) Short-circuit current gain, (iii) input resistance and (iv) output resistance from the small signal equivalent circuit. (23  $\frac{2}{3}$ )
- (b) Calculate the line voltages and line currents for a positive sequence (abc sequence) balanced 3- $\phi$  supply in the circuit of Fig. for Q. No. 2(b). Also calculate the pf (power factor) (23)
3. (a) Find the effective value, form factor and crest factor for the voltage waveshape for figure for Q. No. 3(a). Calculate the average power dissipated in a 6  $\Omega$  resistor. (30)
- (b) For the circuit of Fig. for Q. No. 3(b) calculate  $V_s$ . (16  $\frac{2}{3}$ )
4. (a) Draw the approximate phasor diagrams for the circuit of Fig. for Q. No. 4(a) for (i)  $|i_L| = |i_{C_1}|$  (ii)  $|i_L| < |i_{C_1}|$  (iii)  $|i_L| > |i_{C_1}|$ . (18)
- (b) Determine  $v(t)$  using phasor method. (23  $\frac{2}{3}$ )
- $$\frac{dv}{dt} + 50v + 100 \int_{-\infty}^t v dt = 110 \cos(377t - 10^\circ)$$
- (c) Find  $v_0$  in the circuit of Fig. for Q. No. 4(c) (Use Thevenin's Theorem) (16)

**EEE 167**

**SECTION – B**

There are **FOUR** questions in this Section. Answer any **THREE**.

5. (a) Derive an expression for the small signal resistance of a diode. Also state the condition for which the small-signal approximation is valid. (10 <sup>2</sup>/<sub>3</sub>)  
 (b) Explain with neat sketch the principle of operation of bridge rectifier. Also find the PIV of each diode. (10)  
 (c) Find the values of I and V in the circuit of Fig. for Q. 5(c) (i) and (ii) (assume diodes to be ideal) (13+13=26)
  
6. (a) Find the equivalent resistance  $R_{ab}$  and  $R_{cd}$  of the circuit in Fig. for Q. 6(a) (23 <sup>2</sup>/<sub>3</sub>)  
 (b) Find the current  $I_1, I_2, I_3$ , of the circuit in Fig. for Q. 6(b) (23)
  
7. (a) In Fig. for Q. 7(a) the power absorbed in  $R_L$  is plotted as the value of  $R_L$  is varied. Find the Thevenin voltage and Thevenin Resistance for that linear circuit. (10)  
 (b) What is/are the condition that is needed to be satisfied for the application of superposition theorem in a circuit? Is it applicable for power calculation? Explain. (10 <sup>2</sup>/<sub>3</sub>)  
 (c) Use source transformation to find the voltage  $v_0$  in the circuit shown in Fig. for Q. 7(c)
  
8. (a) Find the Norton equivalent circuit at terminal a – b in Fig. for Q. 8(a) (23)  
 (b) Find the Node voltage  $v_1, v_2$  using Nodal analysis of the circuit shown in Fig. for Q. 8(b) (23 <sup>2</sup>/<sub>3</sub>)

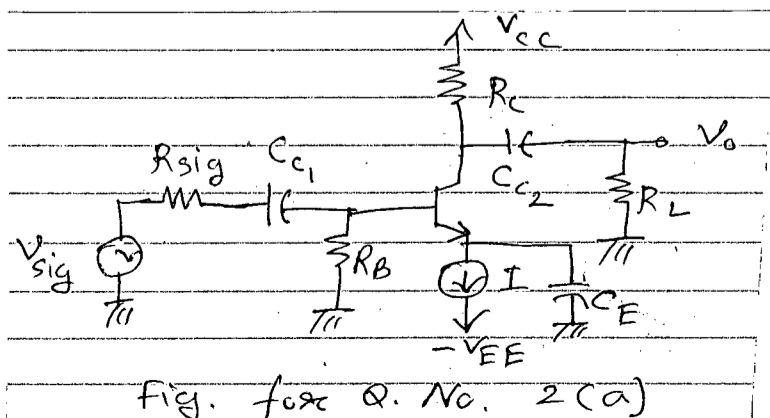
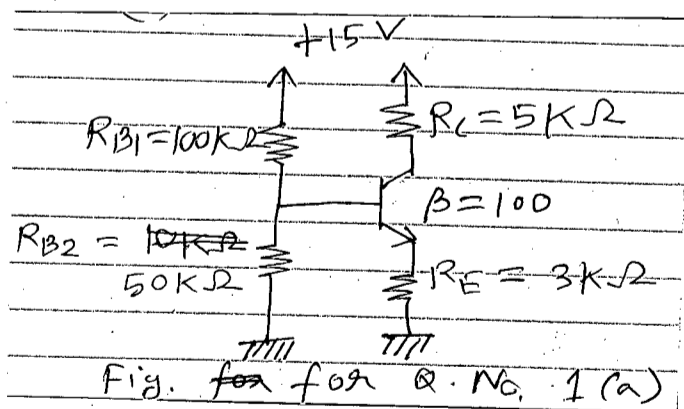

= 3 =

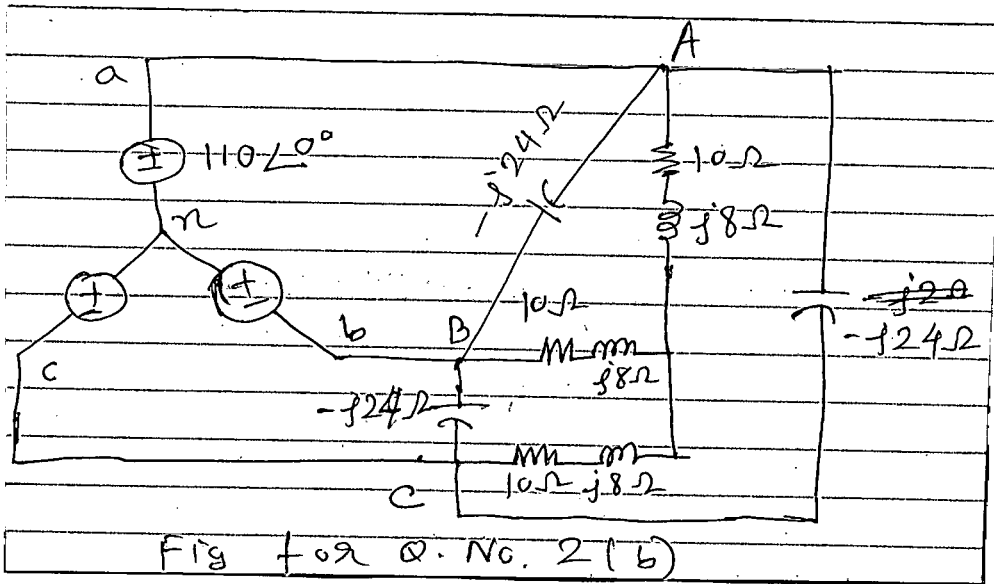

Fig for Q. No. 2 (b)

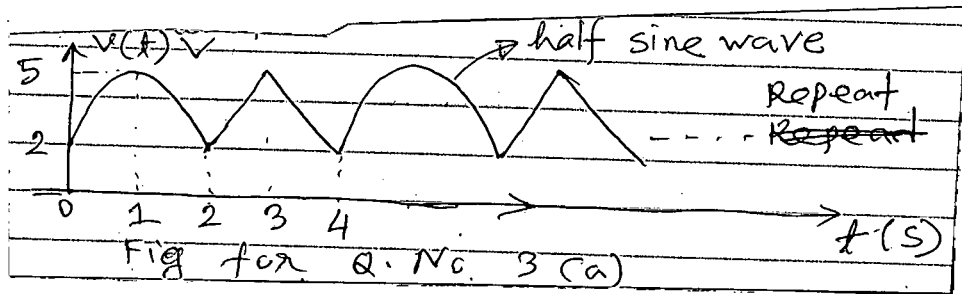

Fig for Q. No. 3 (a)

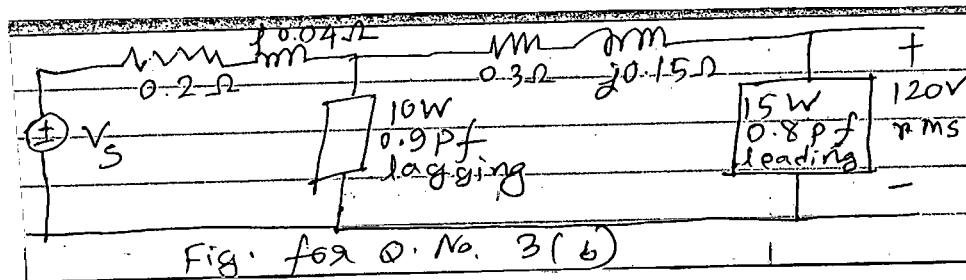

Fig. for Q. No. 3 (b)

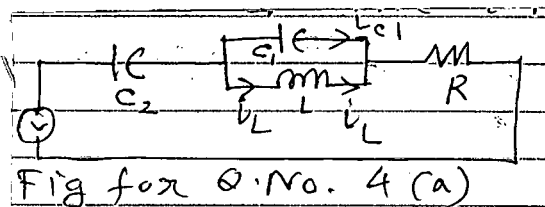

Fig for Q. No. 4 (a)

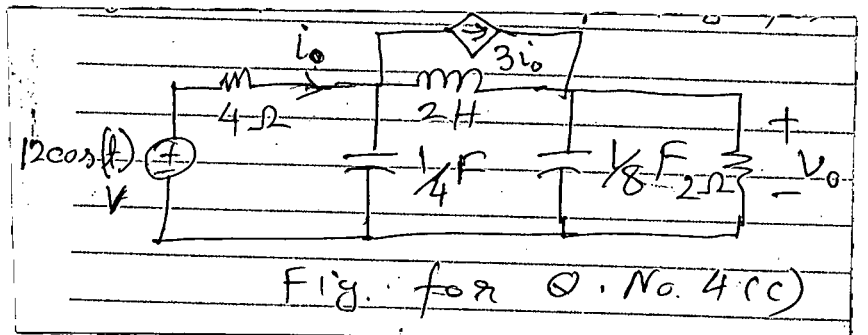

Fig. for Q. No. 4 (c)

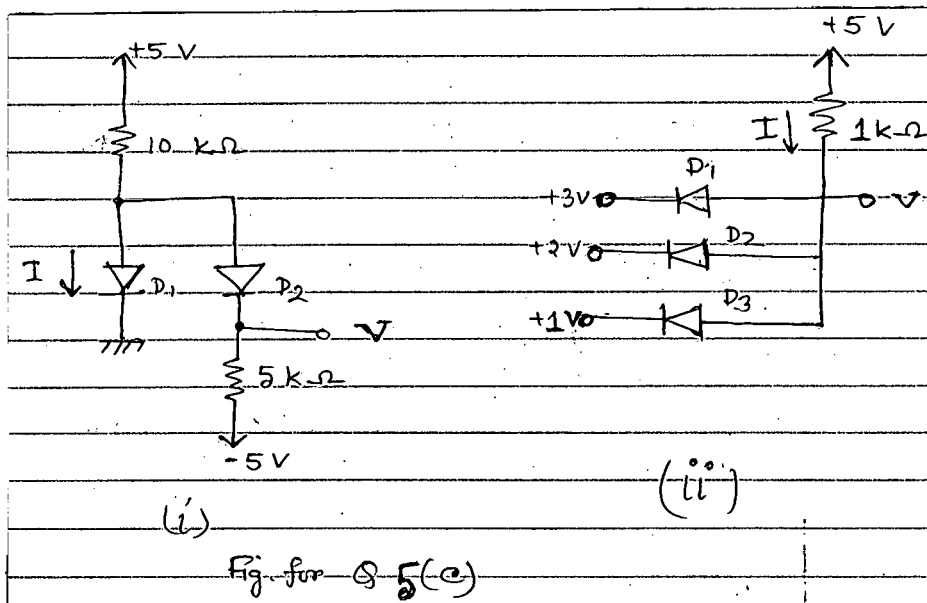
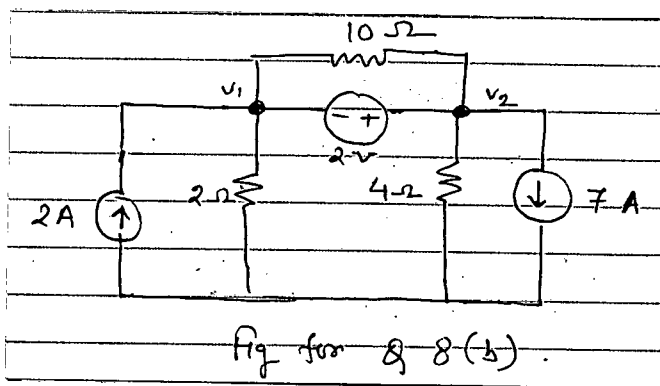
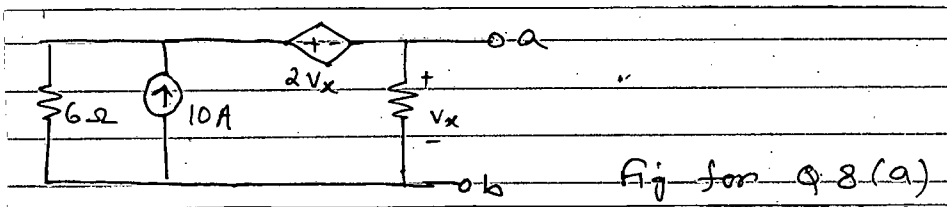
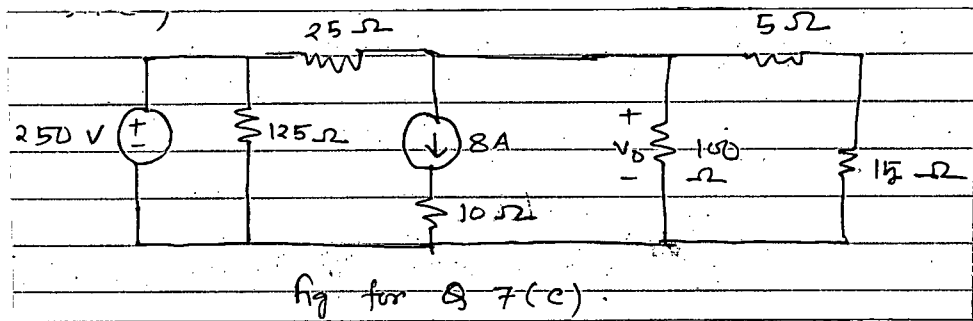
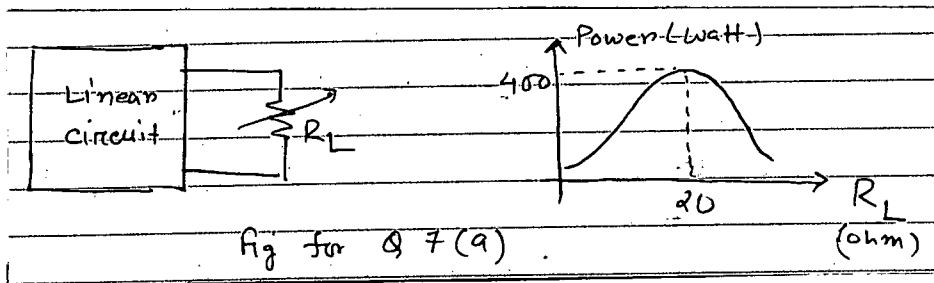
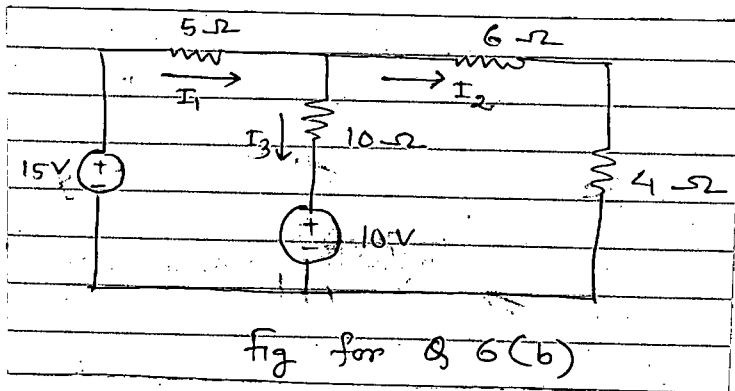
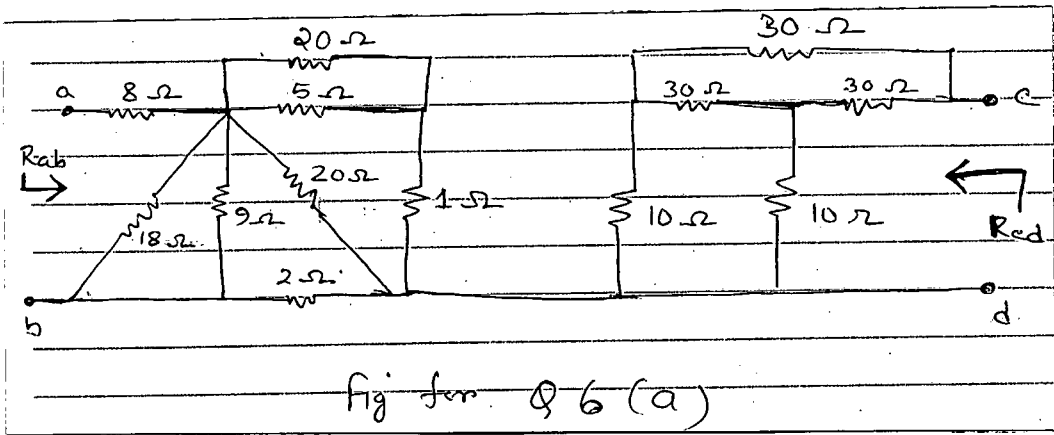

Fig for Q. No. 5 (c)

= 4 =



BANGLADESH UNIVERSITY OF ENGINEERING AND TECHNOLOGY, DHAKA

L-1/T-2 B. Sc. Engineering Examinations 2014-2015

Sub : **CHEM 143** (Chemistry of Materials)

Full Marks : 140

Time : 3 Hours

The figures in the margin indicate full marks.

USE SEPARATE SCRIPTS FOR EACH SECTION

**SECTION – A**There are **FOUR** questions in this Section. Answer any **THREE**.

1. (a) Explain the theory of lubrication. (4 1/3)
- (b) What are the different types of solid lubricants? Write the advantages and disadvantages of solid lubricants. (6)
- (c) Discuss the following properties of lubricating oils: (8)
  - (i) Volatility (ii) Emulsification (iii) Cloud point
- (d) Mention the names and functions of various important additives for lubricating oils. (5)
  
2. (a) With the help of chemical reactions discuss hydrogen evolution and oxygen absorption type underwater corrosion. (6)
- (b) Name the factors which influence the underwater corrosion. Describe their effect in brief. (7)
- (c) Write short notes on any two of the following: (6)
  - (i) Putting corrosion (ii) Uniform corrosion (iii) Prevention of corrosion.
- (d) What do you understand by hydrogen embrittlement and de-carburization? Distinguish between them. (4 1/3)
  
3. (a) What is metallic coating? Describe the different methods of applying protective coatings on the metal surface. (7)
- (b) Give schematic diagram for the manufacture of paint. (6)
- (c) State the functions and required properties of pigments in paint. (5 1/3)
- (d) What is pigment volume concentration (P.V.C) of paint? For a paint manufacturer P.V.C of paint is very important: Explain. (5)
  
4. (a) State the source of the major ingredient of glass and its role in glass making production. (7)
- (b) Write with reactions the melting of the batch materials in the furnace when it is composed of soda, limestone and silica. (5)
- (c) Give some example of refining agents and opalizing agents mentioning their functions in the manufacturer of glass. (6)
- (d) Discuss the prospect of glass industry in Bangladesh. (5 1/3)

**CHEM 143**

**SECTION – B**

There are **FOUR** questions in this Section. Answer any **THREE**.

5. (a) What do you mean by the degree of polymerization? How would you classify polymer based on the degree of polymerization? What are the various forms of the structural polymers? (5 1/3)
- (b) Give the structural formula of each of the following polymers. (4)
- (i) Organic polymer (ii) Inorganic polymer (iii) Homo polymer (iv) Co-polymer
- (c) What are the basic difference between the addition polymerization and condensation polymerization? Explain the mechanistic path of the free radical addition polymerization. (6)
- (d) What are the functions of the following additives that are used for the processing of polymer? (8)
6. (a) What are plastic polymers? Discuss the properties of plastics which render them suitable for their industrial applications. (6)
- (i) Binders (ii) Fillers (iii) Plasticizers (iv) Lubricants
- (b) How the following polymers can be synthesized from its monomer? (6)
- (i) Nylon-6,6 (ii) Bukelite (iii) PVC (iv) Melamine
- (c) What are the basic differences between HDPE and LDPE? Mention some of their industrial applications. (5)
- (d) Describe the industrial manufacturing process of HDPE with flow diagram. (6 1/3)
7. (a) What are the important properties of rubber and how would you differentiate between natural rubber and synthetic rubber? (7)
- (b) Discuss the process of vulcanization of natural rubber. Why it is so important? How vulcanization can be carried out? (8 1/3)
- (c) Describe the functions of the following substances that are used in compounding of natural rubber. (8)
- (i) Accelerator activators (ii) Auto-oxidant (iii) Reinforcing agent (iv) Inert fillers
8. (a) Fibers are polymers but all fibers are not polymer. Explain the statement. (6 1/3)
- (b) Explain the following properties of the synthetic fiber. (8)
- (i) Crimp (ii) Denier (iii) Water absorption capacity (iv) Chemical stability
- (c) What do you mean by rayon? Describe the preparative process of pyroxilin rayon and cuprammonim rayon. (9)
-



**SECTION – A**There are **FOUR** questions in this Section. Answer any **THREE**.

1. (a) What do you mean by torsional pendulum and compound pendulum? Deduce expressions for time periods of both the pendulums. What are the differences between them? (8+18+2)
- (b) A uniform bar of length 100 cm is made to oscillate about an axis through its one end. It's moment of inertia about the axis of suspension is  $\frac{1}{3}ML^2$ . Find the time period and the equivalent length. (7)
2. (a) Define forced oscillation and write down its differential equation mentioning each term. Deduce the solution for steady state. (3+7+15)
- (b) Consider the forced oscillations of a damped block-spring system. Show that at resonance (i) the amplitude of oscillation is  $x_m = \frac{F_m}{b\omega}$  and (ii) the maximum speed of the oscillating block is  $v_{max} = \frac{F_m}{b}$ , where  $b \rightarrow$  damping constant  $\omega \rightarrow$  natural angular frequency and the external driving force  $F = F_m \cos \omega't$ . (10)
3. (a) Write down the characteristics of a mechanical wave. Deduce the one dimensional differential equation of a wave from its displacement equation. (10)
- (b) Define phase velocity and group velocity. Establish a relationship between phase velocity and group velocity of two waves having angular frequencies and wave-lengths are very close. Show that in a non-dispersive medium they are same. (15)
- (c) The motion of ripples of short wavelength on water is controlled by surface tension. The phase velocity of such ripples is given by  $v_p = \left( \frac{2\pi S}{\rho\lambda} \right)^{1/2}$  where S is surface tension and  $\rho$  the density of water. Show that the group velocity for a disturbance made up of wavelengths close to  $\lambda$  is equal to  $\frac{3v_p}{2}$ . (10)

**PHY 163**

4. (a) What do you understand by the term phase space? How many co-ordinates are required to express completely the state of a particle in the phase space? List the main differences between the classical and quantum statistics? (3+2+5)
- (b) Derive the energy distribution function for a photon using Bose-Einstein distribution function. What do you mean by Bose-Einstein condensation? (15)
- (c) Calculate the relative number of atoms of hydrogen gas present in the ground state and the first excited state at room temperature (298 K) and at temperature of 400 K. Assume Maxwell-Boltzman statistics to hold good for the hydrogen gas. (10)

**SECTION – B**

There are **FOUR** questions in this Section. Answer any **THREE**.

5. (a) What is wave function and normalization of wave function of a particle? Write down the postulates of wave function. (2+2+4)
- (b) What do you mean by a particle confined to a Potential box? Show that the energy of an electron in the box varies as the square of the natural numbers. Represent graphically the wave functions and the probabilities of such electron at different quantum states. (4+16)
- (c) Find the probability that a particle trapped in a box of width L can be found between 0.45L and 0.55L for the ground and first excited states. (7)
6. (a) What is operator? Explain what you mean by the expectation value of a particle. How the expectation value differ from average value? (3+3+3)
- (b) Derive the time-dependent schrödinger equation of a particle, and hence find the expression of schrödinger equation at steady state condition. (15+5)
- (c) Write down a typical wave function of a particle. Show that the normalization of that wave function is independent of time. (6)
7. (a) What is meant by coherent Source? Show with a neat diagram how coherent sources are produced in Newton's rings experiment? (7)
- (b) Derive an expression for the radius of the nth dark ring in the case of Newton's rings experiments for reflected light. Why the center is dark in this case? (20)
- (c) If a parallel beam of light of 589.3 nm wavelength is incident at an angle of 45° on a glass plate of refractive index 1.5, calculate the smallest thickness of the glass plate for the fringe of minimum intensity. (8)

**PHY 163**

8. (a) Discuss the Fraunhofer diffraction of light at a circular aperture. (12)
- (b) State Brewster's law. Write down two applications of it. (7)
- (c) Define optic axis and double refraction. (6)
- (d) For a given plane transmission grating having 5000 lines/Cm, answer the followings: (10)
- (i) For a wavelength of 600 nm, what is the highest order of Spectrum observed?
- (ii) If opaque space are exactly twice the transparent Space, which order of Spectra will be absent?

-----

**SECTION – A**

There are **FOUR** questions in this Section. Answer any **THREE**.

1. (a) What is a phase diagram? What do you understand by the terms “phase” and “component”? Give example. (5)
- (b) For the equilibrium diagram shown in Fig. 1 answer the following questions. (15)
  - (i) Which alloy composition has the lowest melting point?
  - (ii) At 600°C what composition range(s) will give only a single phase?
  - (iii) In  $\alpha$  and  $\beta$  what is the solvent and what is the solute?
  - (iv) What is the maximum solubility of Ag in Cu and Cu in Ag and at what temperature?
  - (v) The eutectic mixture contains alternate lamellae of  $\alpha$  and  $\beta$ . When the eutectic mixture first forms (at 780° C), what is the relative amount of each phase inside the mixture and what is their composition?
- (c) What is coring? Using schematic diagrams explain why non-equilibrium cooling results in a cored structure. (15)
2. (a) Write short notes on (i) Ferrite, (ii) austenite (iii) cementite and (iv) pearlite (2.5×4=10)
- (b) Sketch and label the slow cooled microstructure of a 0.3% C and a 0.9% C steel. Considering the composition of pearlite to be 0.76% C and that of ferrite to be 0.008% C, which steel will contain more pearlite? Comment, with reasoning, on the mechanical properties of these two steels. (17)
- (c) What are the types of cast iron? Mention their main features and properties. (8)
3. (a) Give a simplified flowchart of steel production from raw materials to continuous casting. (8)
- (b) “Iron making is a reductive process, while steel making is an oxidative process”- Justify this statement. Discuss the steel making process in an LD converter. (6+15=21)
- (c) Write three advantages and three disadvantages of the LD process. (6)
4. (a) Briefly discuss the four basic heat treatment processes. In your opinion, which one is the most different from the other three? Give reason(s). (7+3)
- (b) The hardness of martensite depends on what factor? Discuss in your own words why martensite forms instead of ferrite during quenching. (3+8=11)
- (d) Write down the working principle and applications of forging, rolling, extrusion and drawing. (3.5×4=14)

**MME 195**

**SECTION – B**

There are **FOUR** questions in this Section. Answer any **THREE**.

5. (a) Define atomic packing factor. Show that the atomic packing factor for body centered cubic crystal is 0.68. (15)
- (b) Differentiate between single crystal and poly crystalline materials. (9)
- (c) Why do atoms assemble into ordered structures (crystals)? (11)
6. (a) With the help of a typical stress-strain diagram, explain (i) modulus of elasticity, (ii) yield strength, (iii) yield strength at a strain off-set of 0.002 and (iv) tensile strength. (20)
- (b) Compare between ductility and malleability. (6)
- (c) A cylindrical specimen of steel having gauge length of 50 mm is tensile tested to fracture. Tensile strength is 450 MPa. If the final gauge length after fracture is 69 mm, determine the ductility of the steel. (9)
7. (a) Discuss the stages of fatigue failure of metal. List four measures that may be taken to increase the resistance to fatigue. (20)
- (b) “Most nonferrous materials do not show any fatigue limit”- explain. (7)
- (c) What do you understand by creep failure of materials? (8)
8. (a) Explain the brittle and ductile fracture of materials. (10)
- (b) Briefly discuss the steps involved in making a casting. (13)
- (c) Write down the causes and remedies of the following casting defects: (12)
- (i) Swell, (ii) Gas holes, (iii) Hot tear and (iv) Misrun
-

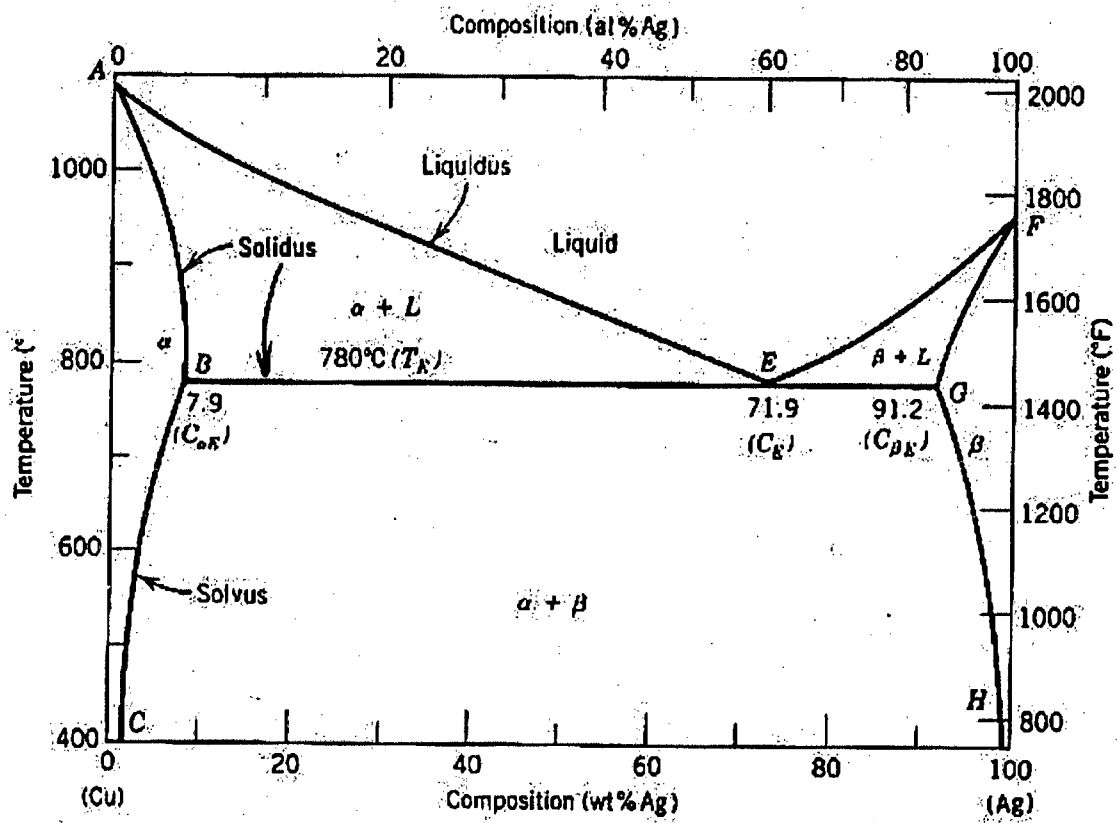

Fig 1 for question 1 (b)

