

SECTION – A

There are **FOUR** questions in this Section. Answer any **THREE**.

1. (a) In the Figure for Q. 1(a) block B starts from rest and moves downward with a constant acceleration. Knowing that after slider block A has moved 9 in. its velocity is 6 ft/s, determine (i) the accelerations of A and B, (ii) the velocity and the change in position of B after 2 s. (20)

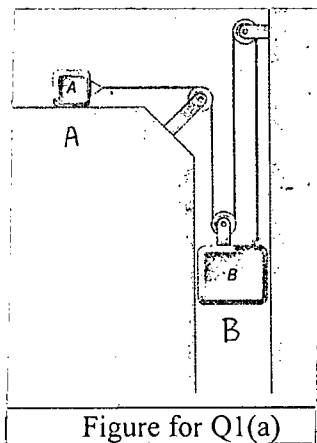

Figure for Q1(a)

- (b) In the Figure for Q. 1(b) a bullet is fired with a horizontal velocity of 1500 ft/s through a 6-lb block A and becomes embedded in a 4.95-lb block B. Knowing that blocks A and B start moving with velocities of 5 ft/s and 9 ft/s, respectively, determine (i) the weight of the bullet, (ii) its velocity as it travels from block A to block B. (15)

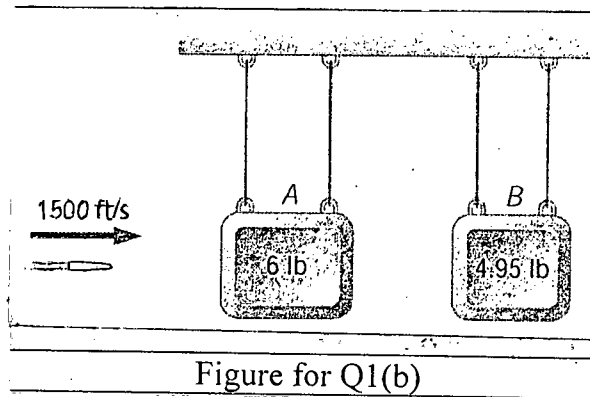

Figure for Q1(b)

2. (a) Rod OA in the Figure for Q. 2(a) rotates about O in a horizontal plane. The motion of the 0.5-lb collar B is defined by the relations $r = 10 + 6 \cos \pi t$ and $\theta = \pi (4t^2 - 8t)$, where r is expressed in inches, t in seconds, and in radians. Determine the radial and transverse components of the force exerted on the collar when $t = 0.5$ s. (20)

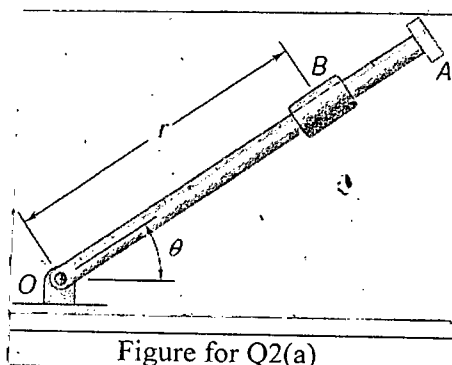

Figure for Q2(a)

ME 141(MME)

Contd ... Q. No. 2

(b) The double gear shown in the Figure for Q2(b) rolls on the stationary left rack R. Knowing that the rack on the right has a constant velocity of 2 ft/s, determine (i) the angular velocity of the gear, (ii) the velocities of points A and D. Use the method of the instantaneous center of rotation.

(15)

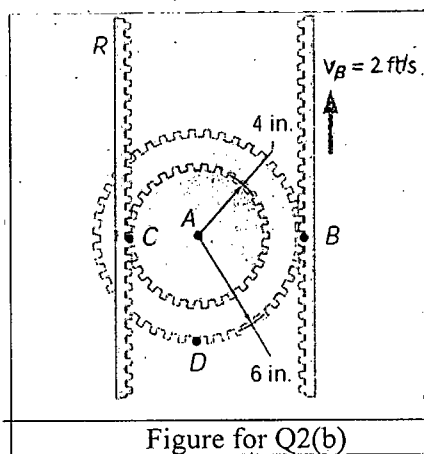

3. (a) In the Figure for Q 3(a) the coefficients of friction between blocks A and C and the horizontal surfaces are $\mu_s = 0.24$ and $\mu_k = 0.20$. Knowing that $m_A = 5$ kg, $m_B = 10$ kg, and $m_C = 10$ kg, determine (i) the tension in the cord, (ii) the acceleration of each block.

(20)

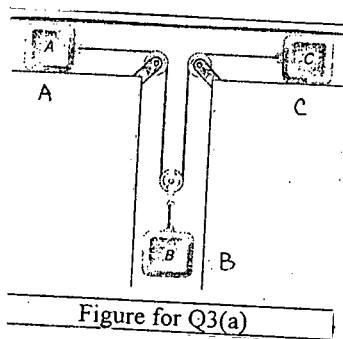

(b) The motion of the 2.5-kg rod AB is guided by two small wheels which roll freely in horizontal slots as shown in the Figure for Q 3(b). If a force P of magnitude 8 N is applied at B, determine (i) the acceleration of the rod, (ii) the reactions at A and B.

(15)

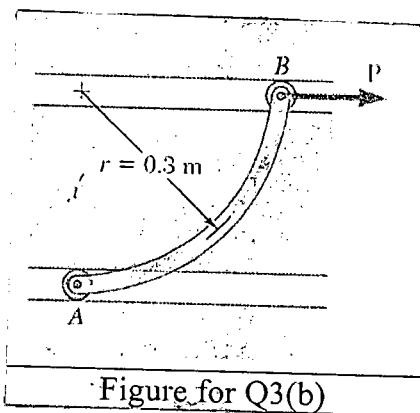

4. (a) A 3-lb collar is attached to a spring and slides without friction along a circular rod in a horizontal plane as shown in the Figure for Q 4(a). The spring has an undeformed length of 7 in. and a constant $k = 1.5$ lb/in. Knowing that the collar is in equilibrium at A and is given a slight push to get it moving, determine the velocity of the collar (i) as it passes through B, (ii) as it passes through C.

(18)

ME 141(MME)

Contd ... Q. No. 4(a)

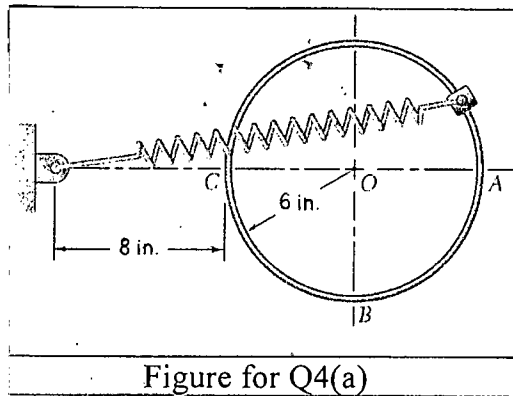

Figure for Q4(a)

- (b) Knowing that at the instant shown in the Figure for Q 4(b) bar AB has a constant angular velocity of 19 rad/s clockwise, determine (i) the angular acceleration of bar BGD, (ii) the angular acceleration of bar DE.

(17)

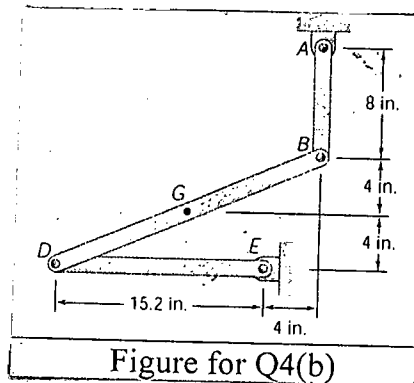

Figure for Q4(b)

SECTION - B

There are **FOUR** questions in this Section. Answer any **THREE**.

5. (a) A 60-kg cylinder is supported by two cables AC and BC, which are attached to the top of vertical posts as shown in Fig. Q. 5(a). A horizontal forces P, perpendicular to the plane containing the posts, holds the cylinder in the position shown. Draw the free-body diagram of point C and determine the magnitude of P.

(20)

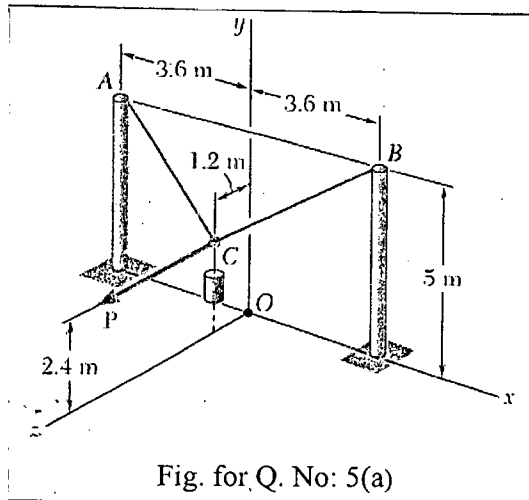

Fig. for Q. No: 5(a)

- (b) A single force **P** acts at **C** in a direction perpendicular to the handle **BC** of the crank shown in Fig. Q. 5(b) . Knowing that $M_x = + 20$ N-m and $M_y = - 8.75$ N-m and $M_z = - 30$ N-m, determine the magnitude of **P**, θ and ϕ .

Contd P/4

ME 141(MME)

Contd ... Q. No. 5(b)

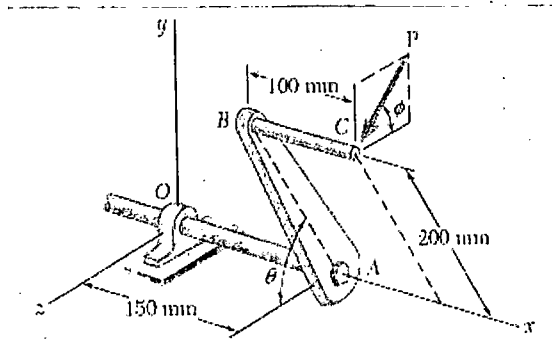

Fig. for Q. No: 5(b)

6. (a) Two Links AB and DE are connected by a bell crank as shown in Fig. Q. 6(a). Knowing that the tension in link AB is 720 N, determine (i) the tension in link DE , (b) the reaction at C .

(15)

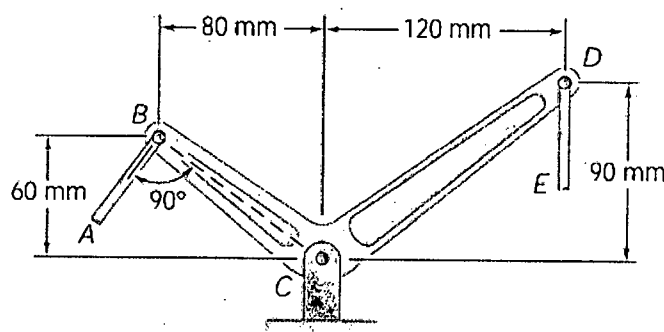

Fig. for Q. No: 6(a)

- (b) Determine by direct integration the centroid of the area shown in Fig. Q. 6(b). Express your answer in terms of a and b .

(20)

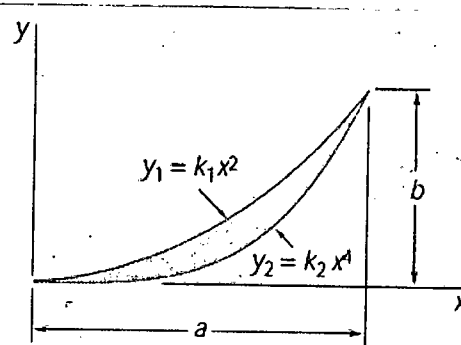

Fig. for Q. No: 6(b)

7. (a) Determine the components of the forces acting on member ACF of the frame shown in Fig. Q. 7(a).

(17)

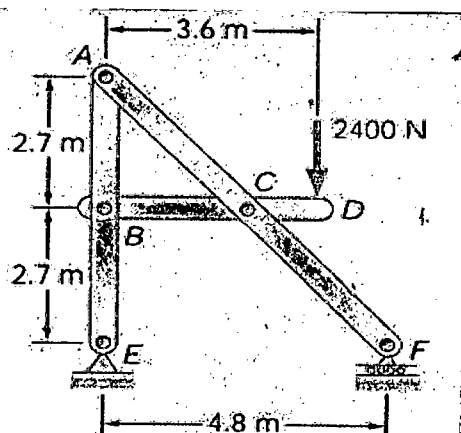

Fig. for Q. No: 7(a)

Contd P/5

ME 141(MME)

Contd ... Q. No. 7

(b) Determine the force in members *CD* and *DF* of the truss shown in Fig. Q. 7(b). (18)

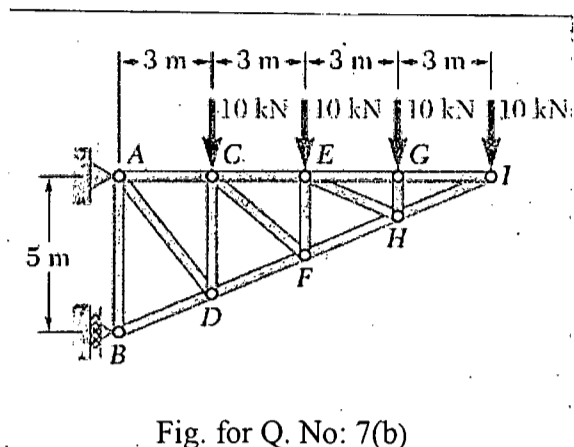

Fig. for Q. No: 7(b)

8. (a) The 20 kg block *A* and the 30 kg block *B* are supported by an incline that is held in the position shown in Fig. Q. 8(a). Knowing that the coefficient of static friction is 0.15 between the two blocks and zero between block *B* and the incline, determine the value of θ for which motion is impending. (17)

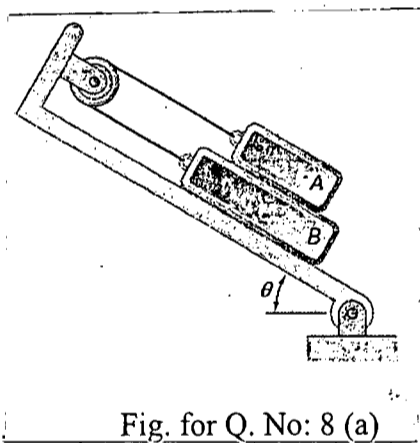

Fig. for Q. No: 8 (a)

(b) Determine the moment of inertia and the radius of gyration of the shaded area shown in Fig. Q. 8(b), with respect to the *x* axis. (18)

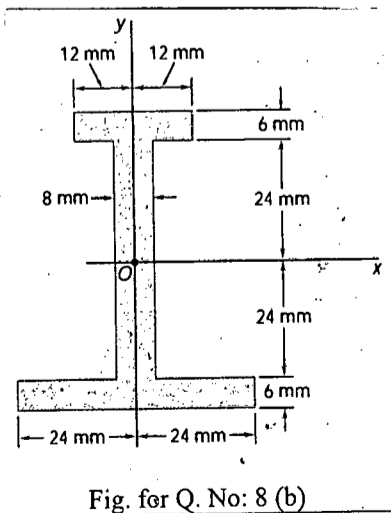

Fig. for Q. No: 8 (b)

BANGLADESH UNIVERSITY OF ENGINEERING AND TECHNOLOGY, DHAKA

L-1/T-2 B. Sc. Engineering Examinations 2014-2015

Sub : **MATH 173** (Vector Analysis and Matrices)

Full Marks : 210

Time : 3 Hours

The figures in the margin indicate full marks.

Symbols have their usual meaning.

USE SEPARATE SCRIPTS FOR EACH SECTION

SECTION - AThere are **FOUR** questions in this Section. Answer any **THREE**.

1. (a) If \vec{u} , \vec{v} and \vec{w} are linearly independent then test whether the given set of vectors $\vec{u} + \vec{v} - 2\vec{w}$, $\vec{u} - \vec{v} - \vec{w}$, $\vec{u} + \vec{w}$ are linearly dependent or independent. (15)

- (b) Suppose that a force \mathbf{F} with a magnitude of 9 lb. is applied to the lever-shaft assembly shown in the accompanying figure (10)

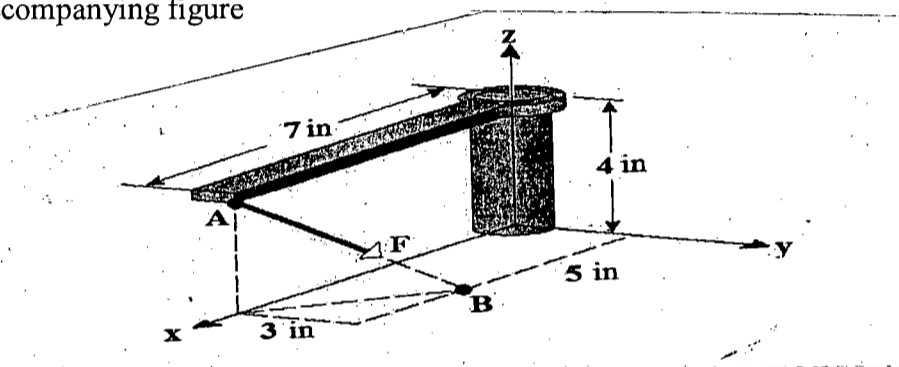

- (i) Express the force \mathbf{F} in component form.
- (ii) Find the magnitude of vector moment of \mathbf{F} about the origin.
- (c) Find the set of reciprocal vectors to the three vectors $2\hat{j} - 3\hat{j} + \hat{k}$, $\hat{i} - \hat{j} - \hat{k}$ and $-\hat{i} + 2\hat{j} + 2\hat{k}$. (10)
2. (a) Find the directional derivative of $f(x, y, z) = x^2 y^2 z^2$ at the point $(1, 1, -1)$ in the direction of the tangent to the curve $x = e^t$, $y = 2 \sin t + 1$, $z = t - \cos t$ at $t = 0$. (10)
- (b) Show that $\text{curl curl } \vec{F} = \text{grad}(\text{div } \vec{F}) - \nabla^2 \vec{F}$. (10)
- (c) Show that $\int_{(1,2)}^{(3,4)} (xy^2 + y^3) dx + (x^2 y + 3xy^2) dy$ is independent of path joining the points $(1, 2)$ and $(3, 4)$. Hence evaluate the integral. (15)
3. (a) Find the angle between the surfaces $x^2 + y^2 + z^2 = 9$ and $x^2 + y^2 - 3 = z$ at the point $(2, -1, 2)$. Also find the equation of tangent line and normal plane to the curve $x^2 + y^2 + z^2 = 9$ and $x^2 + y^2 - 3 = z$ at the point $(2, -1, 2)$. (15)
- (b) State Green's theorem for the plane. Verify Green's theorem in the plane for $\oint_C (3x^2 - 8y^2) dx + (4y - 6xy) dy$, where C is the region bounded by the parabolas $y = x^2$, $x = y^2$. Also determine the area of the region bounded by the parabolas $y = x^2$, $x = y^2$. (20)

MATH 173

4. (a) Evaluate $\iint_S \bar{F} \cdot \hat{n} ds$, where $\bar{F} = z\hat{i} + x\hat{j} - 3y^2z\hat{k}$ and S is the surface of the cylinder $x^2 + y^2 = 16$ included in the first octant between $z = 0$ and $z = 5$. (20)

- (b) If $\bar{F} = x\hat{i} + z^2\hat{j} + y^2\hat{k}$ then evaluate $\iiint_V \vec{\nabla} \cdot \bar{F} dV$, where V is the region bounded by the surface $x + y + z = 1$ and the coordinate planes. (15)

SECTION - B

There are **FOUR** questions in this Section. Answer any **THREE**.

5. (a) Prove that $(I + AB)^{-1} = I - A(I + BA)^{-1}B$. (10)

- (b) Prove that a square matrix A is invertible if and only if it can be written as a product of elementary matrices. Hence express $A = \begin{bmatrix} -1 & -2 \\ 3 & 8 \end{bmatrix}$ as a product of elementary matrices. (17)

- (c) Prove that the points (x_1, y_1) , (x_2, y_2) , (x_3, y_3) are collinear if and only if the rank of

- the matrix $\begin{bmatrix} x_1 & y_1 & 1 \\ x_2 & y_2 & 1 \\ x_3 & y_3 & 1 \end{bmatrix}$ is less than 3. (8)

6. (a) If $A = \begin{bmatrix} 3 & -3 & 4 \\ 2 & -3 & 4 \\ 0 & -1 & 1 \end{bmatrix}$ find two non-singular matrices P and Q such that $PAQ = I$. Hence find A^{-1} . (18)

- (b) For what values of λ and μ , the equations $x + y + z = 6$; $x + 2y + 3z = 10$; $x + 2y + \lambda z = \mu$ have (i) no solution (ii) unique solution and (iii) infinite solutions. (11)

- (c) Prove that A is singular if and only if 0 is an eigenvalue of A . (6)

7. (a) Use Cayley-Hamilton theorem to find the inverse of the matrix $A = \begin{bmatrix} 4 & 3 & 1 \\ 2 & 1 & -2 \\ 1 & 2 & 1 \end{bmatrix}$ and

hence deduce the value $A^5 - 6A^4 + 6A^3 - 11A^2 + 2A + 3I$. (15)

- (b) Find the eigenspace, algebraic multiplicity and geometric multiplicity for each

- eigenvalue for the matrix $A = \begin{bmatrix} -4 & -3 & 6 \\ 0 & -1 & 0 \\ -3 & -3 & 5 \end{bmatrix}$ (20)

8. (a) Reduce the quadratic form $q = x_1^2 + 6x_2^2 + 4x_3^2 - 4x_1x_2 + 6x_1x_3 - 18x_2x_3$ to the canonical form and find rank, index and signature of q . Also write down the corresponding equations of transformation. (23)

- (b) Find the minimal polynomial of the matrix $A = \begin{bmatrix} 2 & 5 & 0 & 0 & 0 \\ 0 & 2 & 0 & 0 & 0 \\ 0 & 0 & 4 & 2 & 0 \\ 0 & 0 & 3 & 5 & 0 \\ 0 & 0 & 0 & 0 & 7 \end{bmatrix}$ (12)

SECTION – A

There are **FOUR** questions in this Section. Answer any **THREE** Questions including No. 1. as compulsory.

1. Read the following passage carefully and answer the questions that follow:

(45)

Like other tyrannies, the tyranny of the majority was first, and is still vulgarly, what in dread chiefly as operating through the acts of the public authorities. But reflecting persons perceived that when society is itself the tyrant – society collectivity, over the separate individuals who compose it – its means of tyrannizing are not restricted to the acts which it may do by the hands of its political functionaries. Society can and does execute its own mandates : and if it issues wrong mandates instead of right, or any mandates at all in things with which it ought not to meddle; it practices a social tyranny more formidable than many kinds of political oppression, since, through not usually upheld by such extreme penalties, it leaves fewer means of escape, penetrating much more deeply into the details of life and enslaving the soul itself. Protection, therefore, against the tyranny of the magistrate is not enough: there needs protection also against the tyranny of the prevailing opinion and feelings, against the tendency of society to impose, by other means than civil penalties, its own ideas and practices as rules of conduct on those who dissent from them; to fetter the development, and if possible, prevent the formation of any individuality not in harmony with its ways and compel all characters to fashion themselves upon the model of its own. There is a limit to the legitimate interferences of collective opinion with individual independence: and to find that limit, and maintain it against encroachment, is as indispensable to a good condition of human affairs, as protection against political despotism.

Questions:

- (i) What does “the tyranny of the majority” mean?
- (ii) When does a society practice social tyranny?
- (iii) How is social tyranny different from political oppression?
- (iv) In a society what sort of protection does an individual require?
- (v) What is essential for nurturing individualism?
- (vi) Write down the meanings of the following words as used in the passage:

Tyranny, meddle, fetter, encroachment, despotism.

HUM 101

2. (a) Write in brief the principles of writing a business letter. (10)
- (b) Draft a suitable reply to a claim made by one of your business clients seeking appropriate steps to be taken in his favour regarding the problems that were identified with the electrical products supplied by you. (10)
- (c) Write the phonetic transcriptions of the following words. (Any five). (10)
- Basic, doulet, among, finger, bone, son.
3. (a) What are the parts of a formal report? Briefly discuss "Back Matter" of a report. (10)
- (b) Write a short essay on any one of the following topics: (10)
- (i) My Favourite subject of study
- (ii) Reading Books : A Habit on the Wane
- (iii) Global Peace : A Need of the Time
- (c) Write a dialogue between two students of MME department sharing their experience of 'MME Day Fest' 2015. (10)
4. (a) Transform the following sentences as directed. (Any five) (10)
- (i) Nobody loves me as much as my mother. (Simple)
- (ii) A lost moment is lost for ever (Complex)
- (iii) A relationship needs to be tended like a plant. (Compound)
- (iv) Hasan was educated at Dhaka University and he joined the Defense service. (Simple)
- (v) Begum Rokeya hit the society for its injustice against women. (Compound)
- (vi) Be just and fear not. (Complex)
- (b) What are the characteristic features of a sales letter? (5)
- (c) Write short notes on any three of the following: (15)
- (i) The Diphthongs
- (ii) Annual Confidential Report
- (iii) Qualities of a good paragraph.
- (iv) Barriers to Communication

SECTION – B

There are **FOUR** questions in this Section. Answer question No. 5 and any 2 (**Two**) from the rest.

5. (a) Explain with reference to the context any two of the following: (15)
- (i) "But the more I read the more complicated the subject seemed to me and the more conscious I grew of my ignorance."
- (ii) "He had a working analysis of mankind's troubles; marriage, money and the tangles of human ties"
- (iii) "Besides legally I had done the right thing, for a mad elephant has to be killed, like a mad dog, if its owner fails to control it."

HUM 101

Contd ... Q. No. 5

- (b) Answer any one of the following: (15)
- (i) The way the children organize themselves parallels the progress of civilization bringing into being the institutions of science, war and religion. --- Justify your answer according to the story of 'Fire on the Mountain'
 - (ii) Do you think that the death of the elephant in 'Shooting an Elephant' symbolizes the probable extinction of imperialism on earth? Give your opinion.
- (c) Answer any three of the following: (15)
- (i) How was the astrologer relieved of the burden he had so long been carrying in his mind?
 - (ii) Why was the author so annoyed with the Burmese natives?
 - (iii) Give a description of the island in which the children found themselves after the plane crash.
 - (iv) What was Maugham's opinion about Bertrand Russell?
 - (v) What did the astrologer do to attract customers?
6. (a) Recast and correct any ten of the following sentences. (15)
- (i) We had a large amount of students on hand for the rally.
 - (ii) Somewheres there must be an answer.
 - (iii) The jury is arguing among itself.
 - (iv) It's a long way home.
 - (v) If I were him, I should not accept the post.
 - (vi) Abraham Lincoln was on of the great men in American history.
 - (vii) If Mary was here now she could show you how to cook.
 - (viii) He is something better today.
 - (ix) Illiteracy is when a man cannot read or write.
 - (x) He didn't speak but once.
 - (xi) He told me what to do with a smile.
 - (xii) He had a need and interest in athletics.
- (b) Give the meanings of and make sentences with any ten of the following words.
Assuage, brandish, concurrence, deprecate, eulogy, moron, pauper, posterity, ratify, sinuous, tyro, vestige. (15)
7. Amplify any one of the following ideas: (30)
- (a) To a good man whether alive no evil can happen.
 - (b) Where there is a wall, there is a way.

HUM 101

8. (a) Write a précis of the following passage with a suitable title:

(30)

A blind reverence for the past is bad and so also is contempt for it, for no future can be founded on this. The present and the future inevitably grow out of the past and bear its stamp, and to forget this is to build without foundations and to cut off the roots of national growth. It is to ignore one of the most powerful forces that influence people. Nationalism is essentially the memory of the past achievements, traditions and experiences; and nationalism is stronger today than it has ever been. Many people thought that nationalism had its day and must inevitably give place to ever-growing international tendencies of the modern world. Trade and commerce, easy communications and rapid transport, the radio and cinema, all helped to create an international atmosphere and to produce the delusion that nationalism was doomed. Yet whenever a crisis has arisen, nationalism has emerged again and dominated the scene, and people have sought comfort and strength in their old traditions.

SECTION – AThere are **FOUR** questions in this Section. Answer any **THREE**.

1. (a) What are the differences between inertial and non-inertial frame of references? (6)
 (b) Derive an expression for the number of interference fringes using Michelson-Morley experiment. (20)
 (c) A certain star is 10.6 light-years away (A light-year is the distance that light travels in one year. $1 \text{ lt - y} = 9.6 \times 10^{15} \text{ m}$). How long does a spaceship take when it's travelling at a speed of $0.96 c$ to reach the star: (9)
 - (i) As measured by stationary observers on earth?
 - (ii) As measured by an observer on the spaceship?
 - (iii) What is the distance traveled according to observer on the spaceship?

2. (a) Briefly describe an automatic bell alarm circuit on the basis of photoelectric effect with a schematic diagram. (11)
 (b) What is de-Broglie hypothesis? Show that wavelength of a matter wave is inversely proportional to the mass of the object. (15)
 (c) A photon of 1 MeV collides with a free and stationary electron which scatters off at 90° . What are the energy of the scattered photon and the kinetic energy of the recoil electron? (9)

3. (a) Define mass defect and binding energy of a nucleus. Draw the graph of binding energy per nucleon vs atomic mass number. Explain nuclear fission and fusion from the graph. (16)
 (b) Write a short note on liquid drop model of the nucleus. (10)
 (c) Find the mean-life of ^{55}Co radionuclide if its activity is decreased by 4% per hour, the decay product is non.-radioactive. (9)

4. (a) What do you mean by ductility, plasticity, elastic hysteresis and elastic after effect?
 (b) What do you mean by torsional rigidity of a material? With suitable diagrams and detailed calculation, show that the twisting couple on a solid cylinder (or wire shaft) can be expressed by the equation: $\tau = \frac{\pi\theta\eta R^4}{2L}$, where the symbols have their usual meanings.

PHY 157

Contd ... Q. No. 4

(c) A copper wire 2 m long and 0.5 mm in diameter, supports a mass of 10 kg. It is stretched by 2.33 mm. Calculate the Young's modulus of the wire.

(7)

SECTION – B

There are **FOUR** questions in this Section. Answer any **THREE**.

5. (a) What do you mean by working stress and factor of safety? Briefly describe the factors that can affect elasticity. (3+3+6)

(b) Explain in details the stress-strain diagram. From the diagram, indicate permanent set, yield point, breaking stress and breaking point along with their corresponding definitions. (15)

(c) Calculate the Poisson's ratio and rigidity modulus of silver. Given, Young's modulus and bulk modulus of the silver are 7.25×10^{11} dyns/cm² and 11×10^{11} dyns/cm² respectively. (4+4)

6. (a) What do you mean by surface tension of a liquid? When the flow of a fluid is said as a steady flow, and for what condition it is a turbulent flow? (2+3+3)

(b) By deriving the Bernoulli's theorem for steady flow of liquid through a horizontal pipe, show that the sum of static pressure and dynamic pressure is constant. (20)

(c) Calculate the limiting velocity of a rain drop. Given that, the diameter of the rain drop is 10^{-3} m, density of water is 10^3 kg/m³, density of air relative to water is 1.3×10^{-3} and the coefficient of viscosity of air is 1.81×10^{-5} Nsm⁻². (7)

7. (a) Explain the statement "Charge is conserved". (8)

(b) Derive an expression for the electric field due to a ring of charge q at a point on its axis passing through the centre. (20)

(c) Two charges $q_1 = +1.0 \times 10^{-6}$ C and $q_2 = +2 \times 10^{-6}$ C are situated 1.0 m apart, at what point on the line joining the two charges, the electric field strength is zero. (7)

8. (a) State and explain Kirchhoff's rules. (8)

(b) Obtain an expression for the growth of charge, q when a capacitor is charged through a resistor for a constant emf. (20)

(c) What is capacitive time constant? Show that the product RC has the dimension of time. (7)

BANGLADESH UNIVERSITY OF ENGINEERING AND TECHNOLOGY, DHAKA

L-1/T-2 B. Sc. Engineering Examinations 2014-2015

Sub : **CHEM 121** (Organic Chemistry)

Full Marks : 210

Time : 3 Hours

The figures in the margin indicate full marks.

USE SEPARATE SCRIPTS FOR EACH SECTION

SECTION – AThere are **FOUR** questions in this Section. Answer any **THREE**.

1. (a) What is conformation? Give the possible conformers of methyl cyclohexane. Draw the Newman projections of the conformers of cyclohexane. (8)
- (b) Write structural formula for each of the following compounds: (10)
 - (i) Allene (ii) (E)-3-Methyl-2-hexene (iii) (E)-2-Bromo-1-Chloro-1-fluoro ethene
 - (iv) (Z)-2-Bromo-2-pentene (v) Trans-3, 4-dimethyl-2-Pentene
- (c) Write equation showing the initiation, propagation and termination steps for the chlorination of methane. Why iodination of methane is not feasible? (8)
- (d) Show the preparation of alkene with mechanism using the following reactions. (9)
 - (i) Dehydrohalogenation of alkylhalides.
 - (ii) Dehydration of alcohol
 - (iii) Boord at al synthesis
2. (a) Explain, why alkynes are more acidic than alkenes and alkanes. (5)
- (b) Write the structure and name of the products expected from the reaction of 2-methyl-2-butene with : (12)
 - (i) O_3 followed by Zn with H^+ (ii) Br_2, H_2O (iii) $C_6H_5CO_3H$
 - (iv) $CHCl_3, (CH_3)_3COK, (CH_3)_3COH$
- (c) Show the preparation of Hexyne-3, vinyl chloride, Vinyl acetate and Butyne-2 from acetylene. (12)
- (d) Give name and examples of three types of unsaturated hydrocarbon with double bonds. (6)
3. (a) Describe a mechanism for the SN^1 reaction showing transition state, configuration and order of reaction. (12)
- (b) Explain the solvent effect on SN^1 and SN^2 reactions. (5)
- (c) What is Lipid? Give the classification of lipids. (10)
- (d) Describe the importance of Lipids in Biological processes. (8)

CHEM 121

4. (a) Make a list of O, P-directing groups which affects the substitution reaction on aromatic compounds. (6)
- (b) Give outline of the preparation of the following: (16)
- (i) Preparation of P-Toluic acid from Toluene
 - (ii) Preparation of m-bromophenol from nitrobenzene
 - (iii) Preparation of Salicylaldehyde from phenol
 - (iv) Preparation of 3-bromo-4-aminotoluene from P-Toluidine.
- (c) Discuss the effects of electron withdrawing group on substitution reactions of aromatic compounds. (6)
- (d) Write the structure of the following compounds. (7)
- (i) Benzylalcohol (ii) Allylbenzene (iii) 1-phenyl-1-chloroethane (iv) Styrene
 - (v) Benzophenone (vi) Vanillin (vii) Piperonal

SECTION – B

There are **FOUR** questions in this Section. Answer any **THREE**.

5. (a) Give a commercial method for the synthesis of pyridine. (3)
- (b) Explain why pyridine is more basic than pyrrole but less basic than trimethyl amine. (5)
- (c) Justify that pyrrole undergoes electrophilic substitution reaction primarily at C-2 position where as pyridine undergoes electrophilic substitution reaction at position C-3. (12)
- (d) Write with reaction how would you bring out the following conversions. (3×5=15)
- (i) Piperidine from pyridine
 - (ii) 2-Aminopyridine from pyridine
 - (iii) 3-Nirtopyridine from pyridine
 - (iv) 2-Phenylazopyrrole from pyrrole
 - (v) 2, 5 – Dihydropyrrole from pyrrole
6. (a) How can you convert tetrahydrofuran into hexamethylene diamine and adipicacid? (9)
- (b) Describe the Bischler-Napieralski synthesis of isoquinoline and a commercial method for the synthesis of indigo. (10)
- (c) Show that furfural undergoes Claisen-Schmidt condensation (4)
- (d) How would you carry out the following conversions? (4×3=12)
- (i) Anthranilic acid from indigo
 - (ii) 2-Hydroxyquinoline from quinoline
 - (iii) Pyridine-3, 4-dicarboxylic acid from isoquinoline
 - (iv) Duahydroisoquinoline from isoquinoline

CHEM 121

7. (a) What are the various degradation methods for the determination of the structure of alkaloids? Describe the Emde method of degradation of alkaloids in brief. (10)
- (b) Explain the Zeisel's method for the determination and estimation of methoxyl groups in an alkaloid. (8)
- (c) Briefly discuss how the structure of coniine was established. (11)
- (d) Mention the various methods for the detection of alkaloids. (6)
8. (a) Describe the structure of benzene in terms of resonance and orbital concept. (9)
- (b) Define aromaticity and write down the conditions for a compound to be aromatic. (9)
- (c) Discuss the bromination of benzene with mechanism. (9)
- (d) Starting with benzene how can you prepare the following: (i) Lindane (ii) DDT (8)
-