

**SECTION – A**

There are **FOUR** questions in this section. Answer any **THREE**.

Assume reasonable values for missing data.

1. (a) Briefly discuss the classification of force systems with examples. (10)
- (b) From the coplanar concurrent force system shown in Figure-1 acting on the irregular body through point "A", determine the resultant force and its direction. Given, weight of the body is 10 lb and acting through point A. (13 1/3)

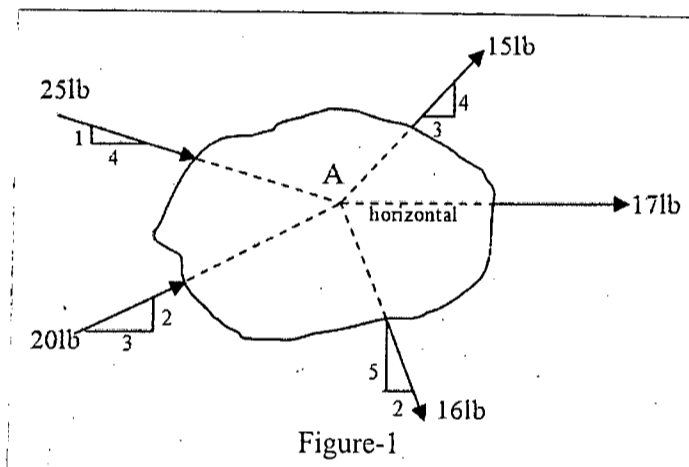

2. (a) There are two spheres A and B shown in Figure-2. Weight and diameter of each sphere is 100 N and 200 mm respectively. Determine the surface reactions on spheres A and B both from vertical and horizontal surfaces in touch with them. (15)

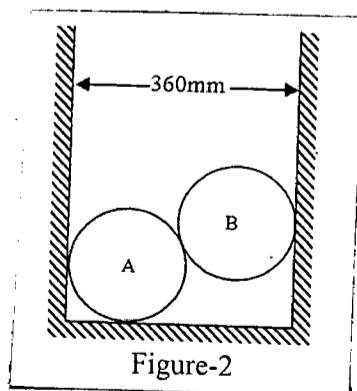

**CE 265**

**Contd... Q. No. 2**

(b) A 3000 lb wheel with a radius of 3 ft is acted upon by a force "F": (Figure-3), which tends to pull the wheel over the obstruction at A. At the instant the wheel is about to move, the pressure between the wheel and the ground is zero. What is the magnitude of the force F at this instant?

**(8 1/3)**

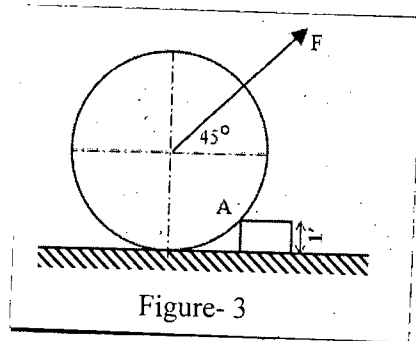

3. (a) Develop an equation showing "Shape of Uniformly loaded cable". Derive equations for maximum tension and the slope of the cable at the supports.

**(10)**

(b) What do you mean by "Catenary"?

**(5)**

(c) A cable is suspended with its ends at the same elevation and 500 ft apart. The load is uniformly distributed horizontally. When the sag is 5% of the span, the maximum tension is 3000 lb. What is the load in pounds per foot?

**(8 1/3)**

4. (a) Define shear force and bending moment with brief discussion on their sign convention.

**(5)**

(b) Find the reactions of the beam shown in Figure-4 and draw its free body diagram.

**(10)**

(c) Draw shear force diagram of the beam (Figure-4).

**(8 1/3)**

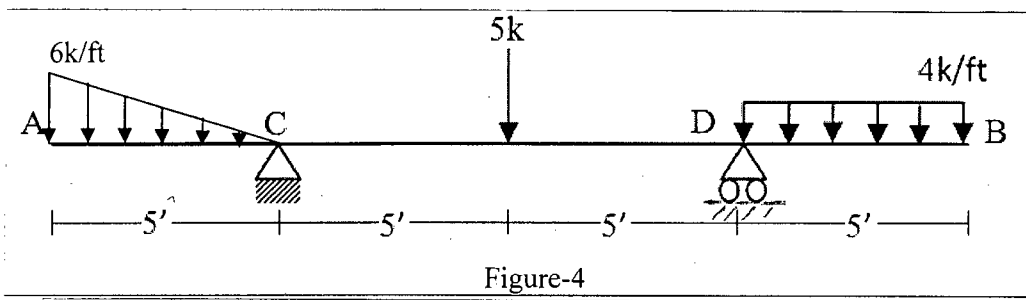

**CE 265**

**SECTION – B**

There are **FOUR** questions in this section. Answer any **THREE**.

5. (a) Define centre of gravity. (3 ⅓)  
(b) Determine the centre of gravity of the area (in the first quadrant) bounded by the curve  $x^2 = 8y$ , the straight line  $x = 4$  inch and the x-axis. (10)  
(c) Determine the x and y coordinates of the centroid of the shaded area shown in Figure-5. (10)
6. (a) Using direct integration method, calculate the moment of inertia of the area mentioned in Q. No. 5(b) about the x-axis. (10)  
(b) Determine the moment of inertias of the unsymmetrical I-section shown in Figure-6 about its centroidal axes. (13 ⅓)
7. (a) For the beam shown in Figure-7, calculate the reactions at the supports. (10)  
(b) Draw the shear force and bending moment diagrams of the simply supported beam loaded as shown in Figure-8. (13 ⅓)
8. (a) Write down the assumptions of an ideal truss. (4)  
(b) For the truss shown in Figure-9, find the forces in the members 'bk', 'cd', 'dj', 'di', 'ij', 'ef' and 'fh'. (19 ⅓)
-

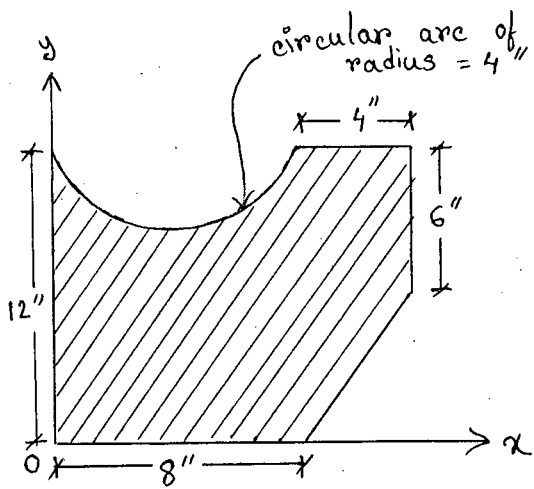

Figure 015

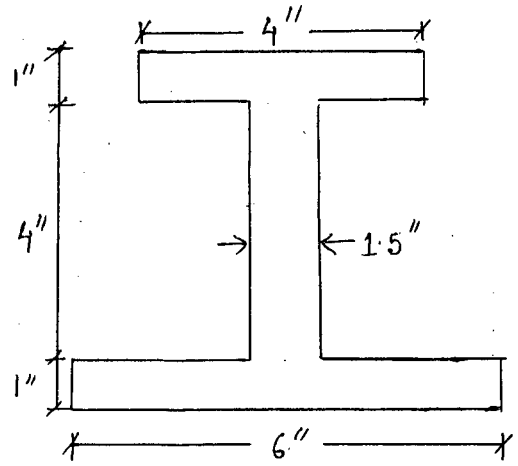

Figure 026

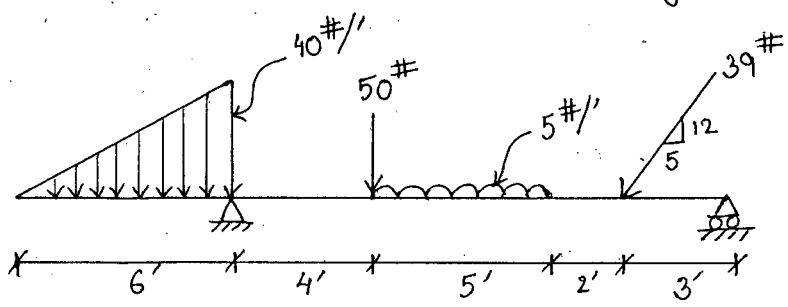

Figure 037

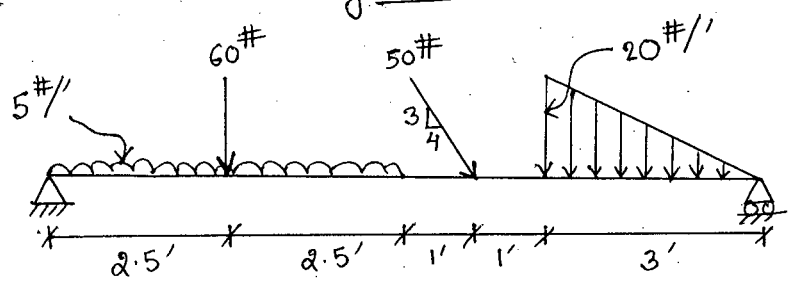

Figure 048

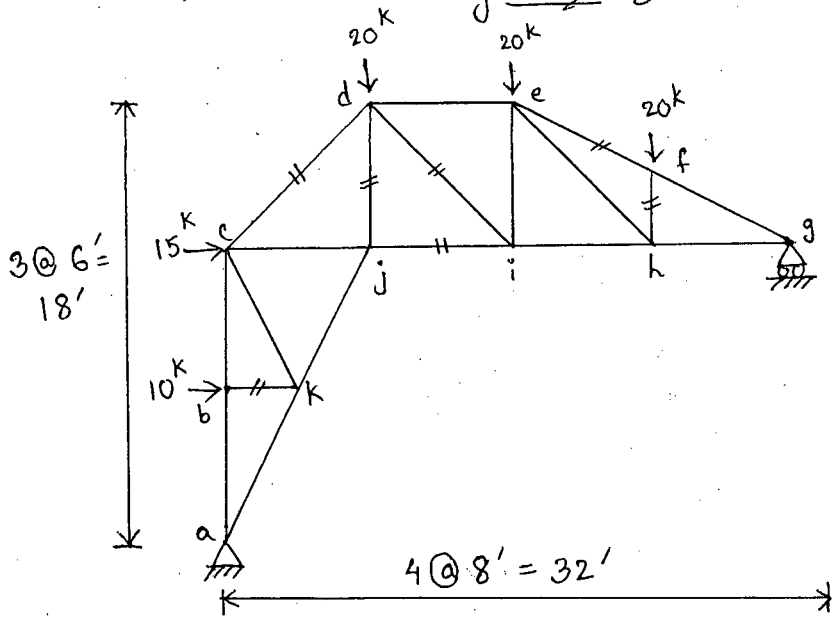

Figure 059

**SECTION – A**

There are **FOUR** questions in this section. Answer Q. No. 1 and any **TWO** from the rest.

1. Write short notes on: (10×3=30)
  - (a) Scalar illumination and illumination vector
  - (b) Sunpath diagram
  - (c) IRC nomogram
  
2. (a) Discuss the concept of Daylight Factor. (5)
  - (b) Explain the use of the BRE Protractor to estimate the sky component of an interior daylight space. (15)
  
3. (a) Differentiate between daylight and electric lights as sources of illuminating interiors. (10)
  - (b) Elaborate on Supplementary Artificial Lighting Systems and their benefits. (10)
  
4. Why do we need to use daylight in buildings? Discuss the benefits and disadvantages of daylight inclusion. (20)

**SECTION – B**

There are **FIVE** questions in this section. Answer Q. No. 5 and any **THREE** from the rest.

5. (a) Write down the appropriate words to fill in the gaps: (5)
  - (i) Basic elements for an acoustic situation are: source, ..... and a receiver.
  - (ii) Frequencies within human hearing capacity are from 20 Hz to ..... kHz.
  - (iii) Noise can be defined as an .....sound.
  - (iv) Lower threshold of human hearing is a sound pressure level of ..... N/m<sup>2</sup>.
  - (v) An ..... chamber has almost no echo, reverberence or background noise within it.
  
- (b) Determine the total absorption at 1 kHz by the wall (including the opening) as shown in Fig. 1. (6)
  
- (c) As shown in Fig. 2, the outdoor noise level of an area is 80 dBA. What will be the indoor noise level, if a brick wall of STC 30 dBA is placed as a noise barrier? (2)

**ARCH 231**

- (d) Does the ceiling in Fig. 3 perform as a diffuser for a 100 Hz sound with a velocity of 340 m/s? (3)
- (e) Write short notes (any TWO): (3×2=6)
- (i) Acoustics
  - (ii) Octave Band
  - (iii) Loudness Level
6. (a) How does sound behave in an enclosed space for reflection, diffraction and refraction? (4×3=12)
- (b) Mention any FOUR significant properties of Sound. (4)
7. (a) With schematic drawings, explain effects of absorption, transmission and diffusion of sound in an enclosed space. (4×3=12)
- (b) (i) What is Reverberation Time? (2+2=4)
- (ii) What are the ranges of recommended Reverberation Times for speech in English and Bangla?
8. (a) Explain the following singular phenomena: (4×3=12)
- (i) Echo
  - (ii) Sound focus and dead spot
  - (iii) Whispering Gallery
- (b) Explain the statement: "Acoustic performance of a space should not be assumed as a post-construction assignment, rather it should be ensured in the design phase". (4)
9. (a) (i) What are the adverse effect of noise on human being? (4×3=12)
- (ii) What are the types of noise in terms of source and transmission path?
  - (iii) Show in schematic drawings, how building elements can act as reflectors for outdoor noise.
- (b) In schematic sections, show examples of 'poor' and 'good' acoustic options for ceiling and balcony design of an auditorium. (4)
-

Fig. 1

Absorption Coefficient of Materials			
Materials	Absorption Coefficient		
	250 Hz	500 Hz	1 kHz
Exposed Concrete	0.02	0.04	0.06
Wood panel	0.25	0.20	0.17
Exposed Brick	0.03	0.03	0.04

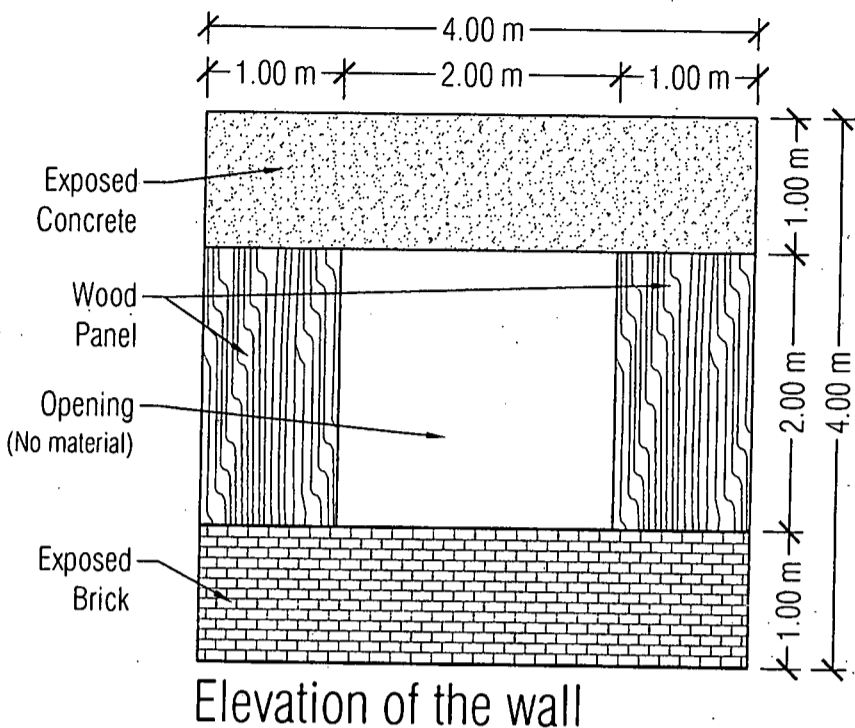

Fig. 2

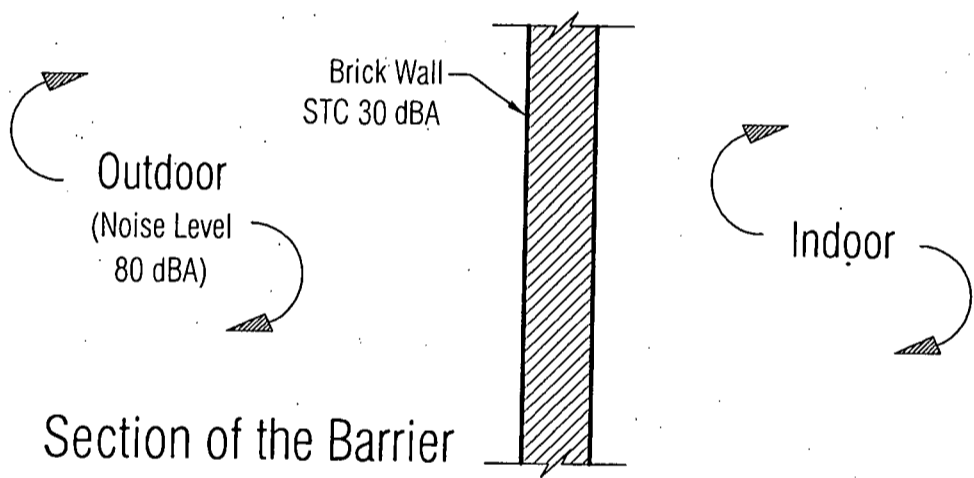
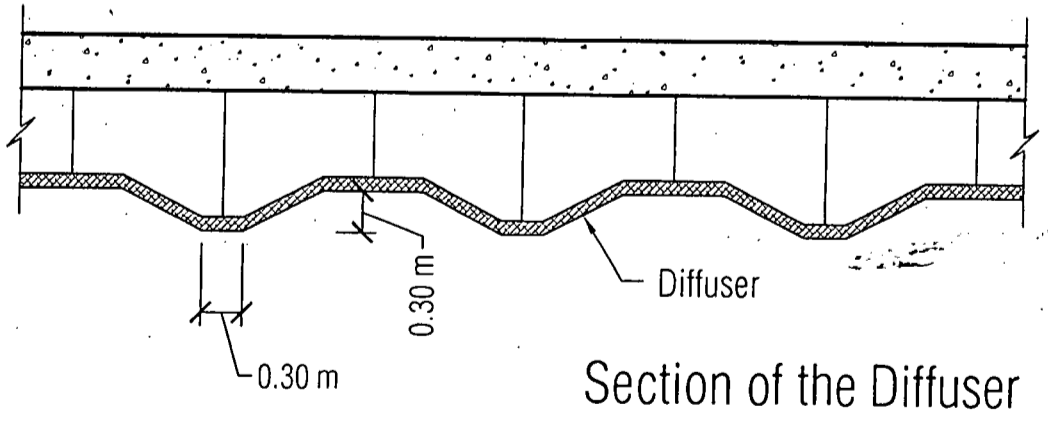

Fig. 3



**SECTION – A**

There are **FOUR** questions in this section. Answer **Q. No. 4** and any **TWO** from the rest.

1. Describe briefly the following types of foundation with sketches. (10×2=20)
  - (a) Wall footing
  - (b) R.C.C column footing
  
2. Discuss the general principles to be followed in brick masonry construction. (20)
  
3. (a) Describe the construction technique of Terrazzo floor. (15)  
(b) Draw the following types of Pitch roof with necessary labeling: (5×1=5)
  - (i) Couple close roof
  - (ii) Collar beam roof
  - (iii) King-post truss
  - (iv) Queen-post truss
  - (v) Mansard roof truss
  
4. Write short notes on the following: (3×10=30)
  - (a) Raft foundation
  - (b) R.C.C beam and slab flooring
  - (c) Cast-in-situ piles

**SECTION – B**

There are **FOUR** questions in this section. Answer **Q. No. 5** and any **TWO** from the rest.

5. (a) Draw the following brick bonds: (6)  
Stretcher bond, Flemish bond, English bond, Garden wall bond, Header bond, Diagonal bond.
- (b) Draw a section of a basement in damp soil showing the method of damp proofing. (8)
- (c) Write short notes (with necessary sketches) (6)
  - (i) Flight (ii) Landing (iii) Balustrade



**ARCH 261**

6. (a) Elaborate on the requirements for a good stair? (10)  
(b) Describe the various types of stairs used in buildings. Illustrate the answer with sketches. (15)
7. (a) Discuss the effects of dampness in buildings in Bangladesh. (10)  
(b) Describe the various methods of prevention of dampness in buildings. (15)
8. (a) Define windows. Write down the design consideration for windows. (10)  
(b) Name various types of windows including figures for each. (15)

-----

**SECTION – A**

There are **FOUR** questions in this section. Answer any **THREE**.

1. (a) Briefly explain the concept of "planning". (7)
- (b) What are the characteristics of planning? "Planning has little or nothing in common with trial and error approaches to problem solving" — do you agree with this statement? Justify your answer with examples. (5+6)
- (c) Describe the procedure of evaluating an alternatives in planning process. (5 $\frac{1}{3}$ )
  
2. (a) State the benefits of stakeholder analysis in the planning process. (7)
- (b) Explain different levels of planning with a neat diagram. (5 $\frac{1}{3}$ )
- (c) Differentiate between indicative planning and imperative planning. (4+7)

What are the key features of innovative planning? Briefly explain them.

  
3. (a) Draw a neat diagram showing different zones in the Concentric Zone Model and explain the functions of each zone. (13 $\frac{1}{3}$ )
- (b) Discuss the criticisms of Multiple Nuclei Theory and Sector Theory. (5+5)
  
4. (a) Describe the purpose and objectives of Spatial Planning. (9)
- (b) Dhaka Transport Coordination Authority (DTCA) is planning to ban private Car movement along Mirpur Road (from New Market to Asad Avenue) to reduce traffic congestion. But before implementing the plan, they want to run a stakeholder analysis. Now develop a stakeholder matrix showing different stakeholders of this plan/decision with relevant examples. (14 $\frac{1}{3}$ )

**PLAN 219**

**SECTION – B**

There are **FOUR** questions in this section. Answer any **THREE**.

5. (a) Mention the factors responsible for the form of cities. Discuss three recognized and basic form of early cities along with their origin. **(7+6)**
- (b) Do you think administrative arrangement or politics can affect the plan and form of cities? Explain in the light of early medieval towns. **(7 1/3)**
6. (a) Among different civilizations of ancient period which one do you think shows best planned features? Discuss its major characteristics. **(2+15)**
- (b) Do you think invention of gunpowder affected the form of Neoclassic cities? Justify your answer. **(6 1/3)**
7. (a) Mention factors responsible for the basic characteristics of any city. Do you think these factors are interconnected? Explain your reasoning. **(12)**
- (b) What rules were formulated in Greek cities to protect open spaces and to improve the environment for the population? **(7 1/3)**
- (c) How do you think King Hamurabi helped to retain the quality of structures built in Babylon in ancient days? **(4)**
8. Discuss the features of early Greek Cities. With time and increased knowledge of architecture and planning, what changes were observed in private dwellings of the city? **(10+13 1/3)**
-

USE SEPARATE SCRIPTS FOR EACH SECTION

The figures in the margin indicate full marks.

Symbols indicate their usual meaning.

**SECTION – A**There are **FOUR** questions in this section. Answer any **THREE**.

1. (a) Define supply function. (5)
- (b) What are the main causes of shifting of the supply curve? Explain them. (10)
- (c) Why do demand curve generally slope downward? (8 1/3)

2. (a) How would you measure price elasticity of demand at any point of a straight line demand curve? Explain graphically. (13 1/3)
- (b) From the following table calculate elasticity of demand if you move from point A to C and explain what you understand from the result. (10)

POINT	Y	Q
A	5000	500
B	6000	600
C	7000	700

3. (a) Explain the properties of an indifference curve. (10)
- (b) Explain consumer's equilibrium with the help of budget line and indifference curve. (8 1/3)
- (c) What are the assumptions of the indifference curve analysis? (5)
4. (a) How is price determined in an economy under competition? What will happen to the price and quantity due to change in supply? (10)
- (b) From the following demand and supply functions, calculate equilibrium price and quantity and show the result in a graph. (13 1/3)

$$P = 0.20 Q + 10$$

$$P = -0.10 Q + 40$$

- (i) What will happen to the equilibrium price and quantity if government imposes a unit tax of Tk 10 per unit?
- (ii) Describe the change in equilibrium. Show the equilibrium coordinates on the same graph.

**HUM 113**

**SECTION – B**

There are **FOUR** questions in this section. Answer any **THREE**.

5. (a) Briefly define the factors of production. Distinguish between a fixed factor and a variable factor with examples. (10)
- (b) Explain the law of diminishing marginal returns with graphical presentations. (13 1/3)
6. (a) Describe the relationship between average and marginal costs of a firm in the short run. Use diagrams. (10)
- (b) What do you mean by revenue of a firm? Derive average and marginal revenue curves for a price-taking firm and also for a firm facing a downward sloping demand curve. (13 1/3)
7. (a) Define an isoquant and an isocost line. Illustrate the least-cost combination of factors to produce a given level of output. (8 1/3)
- (b) Explain the short run profit maximization rule using average and marginal curves. (10)
- (c) What is an envelope curve? (5)
8. Write short notes on any THREE of the following (23 1/3)
- (i) Economies of scale of production
  - (ii) Long run and short run
  - (iii) Gross Domestic Product (GDP) and Gross National Production (GNP)
  - (iv) Circular flow of income of a country.
-