

**SECTION – A**

There are **FOUR** questions in this section. Answer any **THREE**.

All the symbols and notations used in this part have their usual meanings.

1. (a) Explain the concept of "white noise" and "noise bandwidth" as applicable for analog signals processed by integrated circuits. (10)
- (b) Determine the input referred noise voltage of the circuit depicted in Fig. for Q. 1(b) assuming  $M_1$  and  $M_2$  are in saturation. (15)
- (c) For a differential pair circuit, show that (10)

$$\Delta I_D = g_{m0} \left( 1 + \frac{I_n}{2I_{SS}} \right) \Delta V_{in}$$

where,  $g_{m0}$  is the transconductance of the noiseless circuit and  $I_n$  is the noise in  $I_{SS}$ .

2. (a) What is bandgap reference? Explain the concept of temperature-independent voltage generation and actual implementation of that concept in a circuit. (8)
- (b) Draw the PTAT current generation circuit. (5)
- (c) "Constant- $G_m$  biasing" circuit is supply voltage independent but suffers from temperature variation. What can be done to make it temperature independent? (5)
- (d) Address the problems of channel charge injection and clock feedthrough of MOSFET switches. How these problems can be mitigated? (17)
3. (a) Illustrate differential realization of unity gain sampler operated by MOSFET switches from a single clock. (8)
- (b) What will be the output voltage of a switched-capacitor integrator at the  $k^{\text{th}}$  sequence of clock? (5)
- (c) In the circuit of Fig. for Q. 3(c),  $(W/L)_1 = 20/0.5$  and  $C_H = 1$  pF. Calculate the maximum error at the output due to charge injection. Compare this error with that resulting from clock feedthrough. (12)
- (d) Illustrate the conceptual operation of a PFD and implement it using D-FF. (10)

**EEE 351**

- 4. (a) Explain the mechanism of "charge pumping" in PLL. (11)
- (b) Show the effect of skew between  $\bar{Q}_A$  and  $Q_B$  on  $V_{cont}$  of the circuit shown in Fig. for Q. 4(b). (12)
- (c) What is DLL? Draw a 3-buffer stage DLL with PD/CP/LPF combination and determine the closed-loop transfer function of the DLL. (12)

**SECTION - B**

There are **FOUR** questions in this section. Answer any **THREE**.

- 5. (a) On which factors does the threshold voltage of a MOSFET depend? (10)
- (b) For an n-channel MOSFET, show the variation of gate-source and gate-drain capacitances versus  $V_{GS}$ . (10)
- (c) A "ring" MOS structure is shown in Fig. for Q. 5(c). Explain how the device operates and estimate its equivalent aspect ratio. Also calculate the drain junction capacitance of this device structure in terms of  $C_j$ ,  $C_{jsw}$ ,  $W$  and  $L$ . (15)

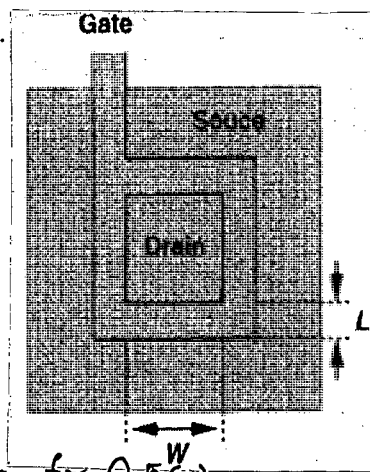

Fig. for Q.5(c)

- 6. (a) Using the small signal equivalent circuit of a "source follower" amplifier, derive an expression for the voltage gain of this amplifier. (10)
- (b) Calculate the voltage gain of the circuit shown in Fig. for Q. 6(b). (10)

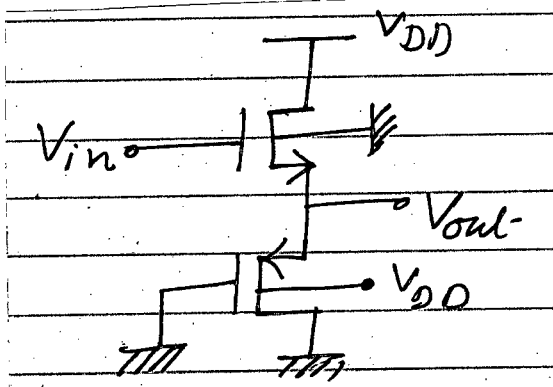

Fig. for Q. 6(b)

- (c) Calculate the output impedance of the folded cascode shown in Fig. for Q. 6(c) where  $M_3$  operates as a current source. (15)

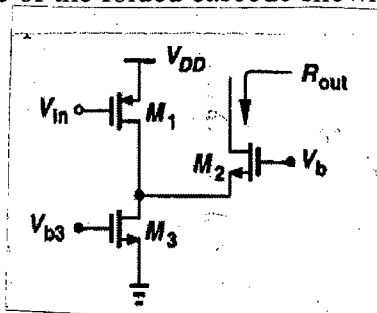

Fig. for Q. 6(c)

**EEE 351**

7. (a) Determine the common-mode response of a differential pair in the presence of resistor mismatch. (8)
- (b) Draw a differential pair with MOSFET load. What measure can be taken to increase the differential voltage gain of this differential pair? (10)
- (c) For the circuit of Fig. for Q. 7(c),  $R_{SS} = 500 \Omega$ . Assume,  $(W/L)_{1,2} = 25/0.5$ ,  $\mu_n C_{ox} = 50 \mu A/V^2$ ,  $V_{TH} = 0.6 V$ ,  $\lambda = \gamma = 0$ , and  $V_{DD} = 3 V$ . (17)
- (i) What is the required input CM voltage for which  $R_{SS}$  sustains 0.5 V?
- (ii) Calculate  $R_D$  for a differential gain of 5.
- (iii) What happens at the output if the input CM level is 50 mV higher than the value calculated in (i)?

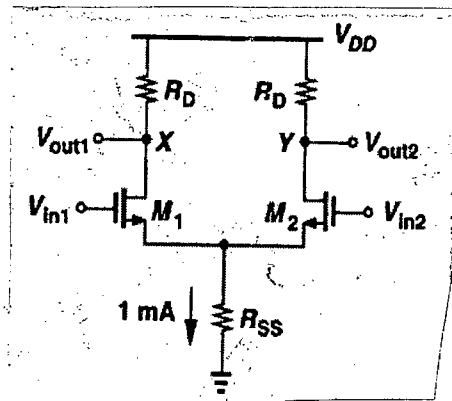

Fig. for Q. 7(c)

8. (a) Explain the conceptual means of copying current in a CMOS Analog Circuit. (7)
- (b) Draw a circuit showing generation of gate voltage  $V_b$  for cascode current mirrors. (10)
- (c) Due to a manufacturing defect, a large parasitic resistance  $R_1$ , has appeared in the circuit of Fig. for Q. 8(c). Calculate the differential gain of the circuit. (18)

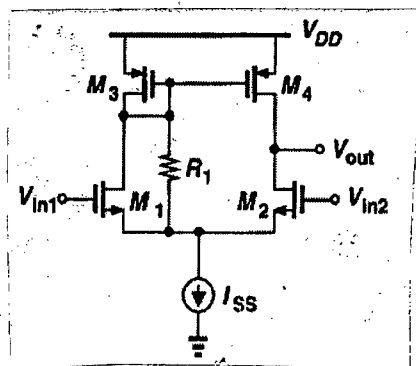

Fig. for Q. 8(c)

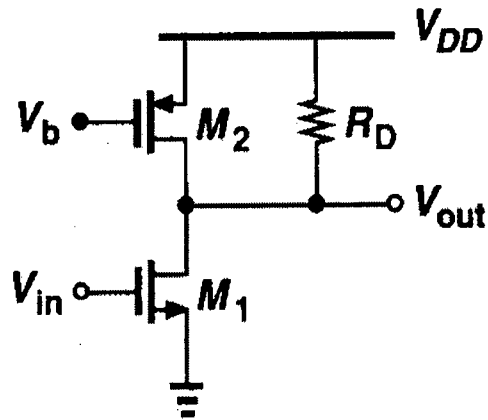

Fig. for Q. 1(b)

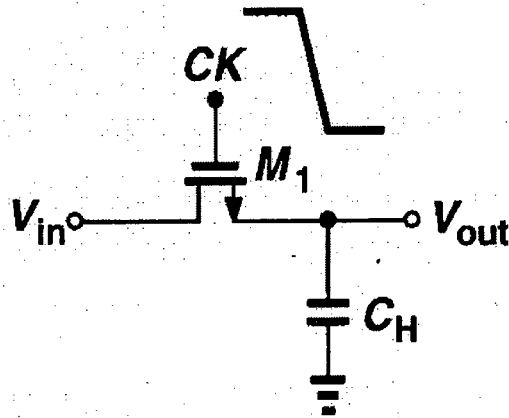

Fig. for Q. 3(c)

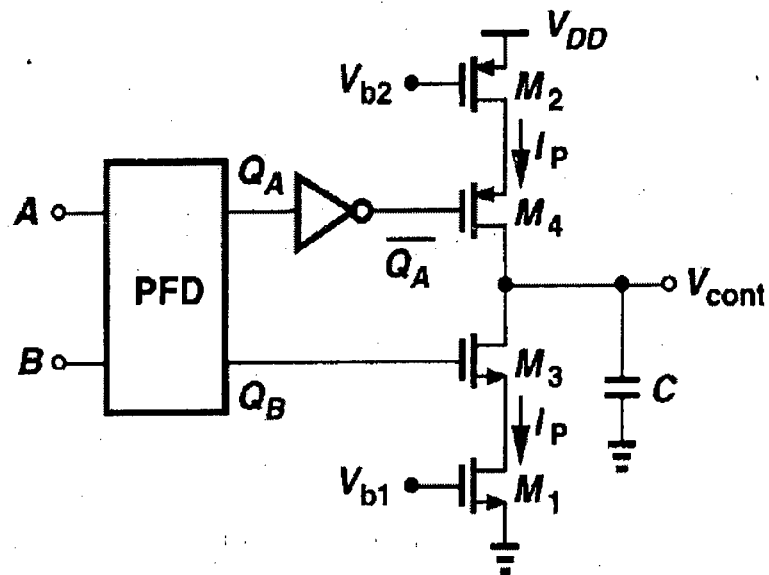

Fig. for Q. 4(b)

The figures in the margin indicate full marks.

Symbols have their usual meanings.

USE SEPARATE SCRIPTS FOR EACH SECTION

**SECTION – A**

There are **FOUR** questions in this Section. Answer any **THREE**.

1. (a) A company purchases ICs from the supplier A, B and C of amount 5,000, 6,000 and 10,000, respectively. There are 50, 100 and 50 defective ICs in the lot provided A, B and C, respectively. If the ICs are mixed, find the probability of an IC being defective. Next, determine the probability that a defective IC is from supplier B. Determine the probability that in the mixed lot, at least 3 ICs are defective. (15)

- (b) The joint probability density function (pdf) of two random variables X and Y is given by (20)

$$f_{X,Y}(x,y) = 25e^{-5y}; \quad 0 < x < 0.2, \quad y > 0$$

Find (i) COV (X, Y) and (ii)  $\rho_{X,Y}(x, y)$  where  $\rho_{X,Y}$  denotes the correlation coefficient.

2. (a) A random variable X has the following pdf:  $f_X(x) = Ce^{-2x}U(x)$  (15)

Determine (i) the value of C, (ii)  $F_X(x)$ , (iii)  $\Pr(X > 2)$  and  $\Pr(X < 3 | X > 2)$

- (b) The joint pdf of two random variables X and Y is given by

$$f_{X,Y}(x,y) = \frac{1}{2}e^{-(x+y)}; \quad 0 \leq x \leq 4 \text{ and } 0 \leq y \leq 6 \quad (20)$$

For the random variable Z, where  $Z = \frac{X^2}{Y}$ , find  $f_Z(z)$ .

3. (a) The probability distribution function (PDF) of an electronic equipment is given by (35)

$$F_X(x) = 1 - e^{-x/5}; \quad x \geq 0$$

$$= 0; \text{ otherwise}$$

where X represents the lifetime. Determine:

(i) the mean lifetime

(ii) the variance of the lifetime

(iii)  $\Pr(X > 20)$  and its upper bound using Markov's inequality. Comment on the results.

(iv)  $\Pr(10 < X \leq 20)$  and  $\Pr(30 < X \leq 40)$ . Comment on the results.

If an electronic system is built by connecting several such electronic equipments, (mentioned above), as shown in Fig. 1, find the reliability and hazard function of the system. Assume that the various components of the system are independent of each other.

**EEE 331**

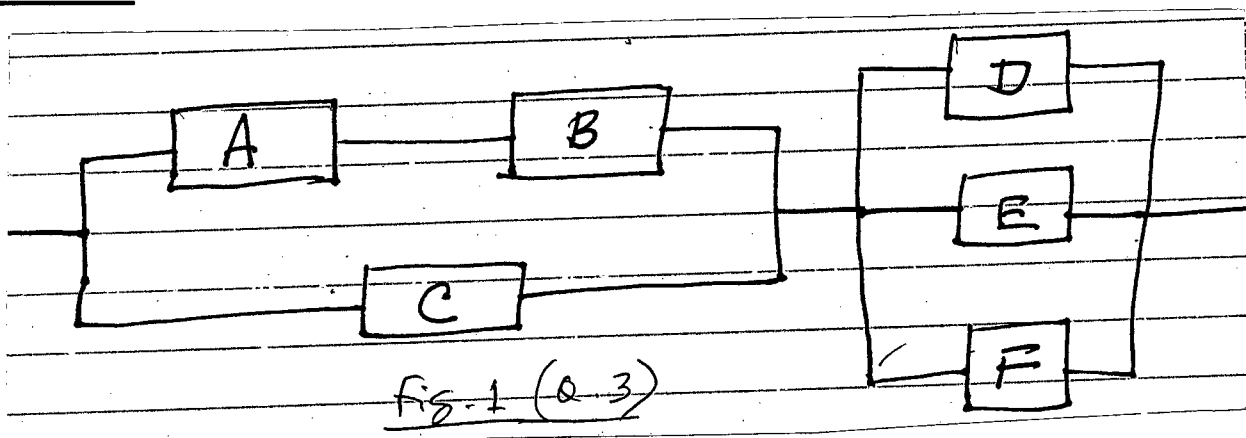

4. (a) The pdf of the random variable Y is given by (15)

$$f_Y(y) = 0.1; 30 \leq y \leq 40$$

$$= 0; \text{ otherwise}$$

Find  $E(X | X \leq 35)$ .

(b) Two random variables X and Y are known to be Gaussian. Their joint pdf is given by (20)

$$f_{X,Y}(x, y) = \frac{1}{\pi\sqrt{3}} \exp\left\{-\frac{2}{3}(x^2 - xy + y^2)\right\}$$

Determine (i)  $f_X(x | y)$ , (ii)  $E(X | Y)$  and (iii)  $\text{Var}(X | Y)$

**SECTION - B**

There are **FOUR** questions in this Section. Answer any **THREE**.

5. (a) Define characteristic function of a random variable X, denoted as  $\Phi_X(\omega)$ . Show that  $\Phi_X(\omega)$  holds the following properties: (18)

- (i)  $\Phi_X^*(\omega) = \Phi_X(-\omega)$ .
- (ii)  $|\Phi_X(\omega)| \leq 1$ , for real  $\omega$ .
- (iii)  $\Phi_X(\omega)$  is real if the p.d.f. of X is even symmetric.
- (iv)  $\Phi_X(\omega)$  cannot be purely imaginary.

(b) In a video processing system, a video sequence consists of  $512 \times 512$  pixels. Assume that the pixels are gray level and can be considered as independent and identically distributed (i.i.d.) random variable X. Determine the following

- (i)  $\text{Pr}\{X \leq 100\}$
- (ii)  $\text{Pr}\{128 \leq X \leq 200\}$ .

6. (a) The impulse response of an LTI system is  $h(t) = 4 e^{-2t} u(t)$ . (20)

The output of this system for an applied input X(t) is Y(t). Given that the autocorrelation function of the random process X(t) is

$$R_{XX}(\tau) = 5 e^{-|\tau|}$$

Find (i)  $S_{XX}(\omega)$ ,  $S_{XY}(\omega)$  and  $S_{YY}(\omega)$

**EEE 331**

**Contd ... Q. No. 6**

(ii)  $R_{XY}(\tau)$  and  $R_{YY}(\tau)$

(iii)  $S_{XX}(\omega)$  and  $S_{YY}(\omega)$

(b) Two discrete-time random processes  $P(n)$  and  $Q(n)$  are obtained by sampling random process  $X(t)$  and  $Y(t)$  at 10 sec. sampling interval. Determine (15)

(i)  $S_{PP}(\omega)$  and  $S_{QQ}(\omega)$

(ii)  $R_{PP}(\tau)$  and  $R_{QQ}(\tau)$ .

7. A random process  $X(t)$  has the following autocorrelation function (15)

$$R_{XX}(\tau) = \frac{4\tau^2 + 6}{\tau^2 + 1}$$

(a) Find (i)  $E\{x\}$ , (ii)  $\sigma_x^2$  and (iii)  $C_{XX}(\tau)$

(b) (i) Is  $X(t)$  an uncorrelated random process? (20)

(ii) Does  $X(t)$  have a DC component?

(iii) Find if  $X(t)$  is mean ergodic in the mean-square sense.

(iv) Determine if  $X(t)$  has derivative in the mean-square sense.

8. (a)  $X(t)$  and  $Y(t)$  are zero mean independent WSS random process.  $X(t)$  and  $Y(t)$  are jointly stationary. Given that (18)

(i)  $S_{XX}(\omega) = \frac{4}{\omega^2 + 4}$  and

(ii)  $S_{YY}(\omega) = \frac{\omega^2}{\omega^2 + 4}$

and  $V(t) = X(t) + Y(t)$

$W(t) = X(t) - Y(t)$

Determine (i)  $\sigma_x^2$  and  $\sigma_y^2$

(ii)  $S_{VW}(\omega)$

(iii)  $R_{VW}(\tau)$ .

(b) A random process  $X(t)$  is expressed as (17)

$$X(t) = A \cos(\omega_0 t + \theta)$$

Where  $\omega_0 = \text{constant}$ ,  $\theta$  is a random variable uniformly distributed in the interval 0 to  $2\pi$ , and  $A$  is a WSS random process independent of  $\theta$ .

Another random process  $Y(t)$  can be expressed in a similar fashion as

$$Y(t) = A \cos((\omega_0 + \omega_1)t + \theta)$$

Where  $\omega_1 = \text{constant}$ , verify whether

(i)  $X(t)$  and  $Y(t)$  are WSS or not

(ii)  $X(t)$  and  $Y(t)$  are jointly stationary or not.

-----

**SECTION – A**

There are **FOUR** questions in this Section. Answer any **THREE**.

1. (a) Consider an investment project with the following net cash flow: **(16)**

Year	Net cash flow (\$)
0	- 1,000
1	- 800
2	500
3	500
4	500
5	1,200

Compute the IRR for this investment.

- (b) What is market segmentation? Give two example of each of the following target market pattern: **(1+8)**

- i) Product specialization
- ii) Market specialization
- iii) Selective specialization
- iv) Full market coverage

- (c) Suppose you need to perform the periodic performance review of your class representative. Now prepare a performance evaluation sheet using Behavior Observation Scale (BOS) method of performance appraisal. (Mention at least five observed behavior) **(10)**

2. (a) Consider the following LP model: **(25)**

Minimize,  $Z = 3x_1 + 2x_2 + 7x_3$

Subject to,

$$-x_1 + x_2 = 10$$

$$2x_1 - x_2 + x_3 \geq 10$$

and  $x_1 \geq 0, x_2 \geq 0, x_3 \geq 0$

- (b) Identify the market leader and the market challenger in the following product market: **(10)**

- i) Portable music player
- ii) Social networking website
- iii) Internet search (web search engine)
- iv) Personal computer processor
- v) Mobile phone



**IPE 493**

3. (a) Mention one, company who segments its target market on the basis of user status. How it is done? (7)
- (b) Suppose you are the owner of a company. You need to recruit few employees for your company from outside. What are the available sources of recruitment for you? (8)
- (c) All leaders are managers. Do you agree? Justify your answer. (6)
- (d) How does Maslow’s need theory differ from ERG theory? (6)
- (e) What do you understand by span of management control? Which span of management is better and why? (8)
4. (a) Consider the following problem. (20)
- Maximize,  $Z = 4x_1 + 3x_2 + 6x_3$
- Subject to,  $3x_1 + x_2 + 3x_3 \leq 30$
- $2x_1 + 2x_2 + 3x_3 \leq 40$
- and  $x_1 \geq 0, x_2 \geq 0, x_3 \geq 0$
- (b) What are the stages of product life cycle? Name at least two product of each life cycle stage. (2+8)
- (c) Give one example of the following business concepts: (5)
- i) Production concept
  - ii) Product concept
  - iii) Selling concept
  - iv) Marketing concept
  - v) Societal marketing concept

**SECTION – B**

There are **FOUR** questions in this Section. Answer any **THREE**.

5. (a) Compare quantitative techniques and qualitative techniques in forecasting. (10)
- (b) The manager of a seafood restaurant was asked to establish a pricing policy on lobster dinners. Experimenting with prices produce the following data. (15)

Average number Sold per day	Price	Average number sold per day	Price
200	\$ 6.00	160	\$ 8.00
190	6.50	155	8.25
188	6.75	156	8.50
180	7.00	148	8.75
170	7.25	140	9.00
162	7.50	133	9.25

**IPE 493**

**Contd . . . Q. No. 5(b)**

- i) Determine the formula which relates average number sold per day and price.
- ii) Determine co-efficient of correlation.

(c) Processing times and due dates for six jobs waiting to be processed at a work center are given in the following table. Determine the sequence of jobs with average flow time and average lateness using SPT and DDATE rules. **(10)**

Job	Processing time (Days)	Due Date (Days)
A	2	7
B	8	16
C	4	4
D	10	17
E	5	15
F	12	18

6. (a) A jewelry firm buys semiprecious stones to make bracelets and rings. The suppliers quotes a price of \$ 8 per stone for quantities of 600 stones or more, \$9 per stone for orders of 400 to 599 stones and \$10 per stone for lesser quantities. The jewelry firm operates 200 days per year. Usage rate is 25 stones per day, the cost of placing an order is \$28 and receiving an order is \$20. **(20)**

- i) If carrying costs are \$2 per year for each stone, find the order quantity that will minimize the total annual cost.
- ii) If annual carrying costs are 30 percent of unit cost, what is the optimal order size?
- iii) If lead time is 6 working days, find the reorder point.

(b) A group of six jobs is to be processed through a two-machine flow shop. The first operation involves cleaning and the second involves painting. Determine a sequence that will minimize the total completion time for this group of jobs. Also determine total minimum completion time. **(15)**

Job	Processing Time (Hours)	
	Work center 1	Work center 2
A	5	5
B	4	3
C	8	9
D	2	7
E	6	8
F	12	15

**IPE 493**

7. (a) A company sold 1,000 units of mobile sets at \$100 per unit in last month. Variable expenses was \$60 per unit and total fixed expenses was \$20000. Now company wants to increase sales by 505 then variable expenses will be increased by 10% and total fixed expenses will also increase by \$ 11,000. What will happen to company's net operating income? Should company increase their sales? **(15)**
- (b) What are the different costs of quality? Explain with examples. **(20)**
8. (a) "Three skills are essential to a manager and their relative importance depends on the manager's rank in the organization." Justify this statement. **(8)**
- (b) "The effectiveness of a decision depends on the quality of the decision, the commitment made to the decision and the time expended to make the decision." How does Vroom Jago model stand this statement? **(6)**
- (c) "The most effective leadership style varies with the "readiness" of employees." Which leadership model holds this observation and how? **(15)**
- (d) McGrigor identified two different sets of assumptions about employees. What are those? Explain. **(6)**
-

**SECTION – A**

There are **FOUR** questions in this Section. Answer any **THREE**.

1. (a) Discuss various measures for improving the transient stability of a power system. (15)  
 (b) A 50 Hz synchronous machine with an inertia constant (H) of 8.0 p.u. -sec was delivering 1.0 p.u. power to a large grid system through a double circuit transmission line. When its rotor was at angle of  $28.44^\circ$  from the references a 3- $\phi$  fault occurred at the midpoint of the second circuit. The faulted circuit was tripped by breakers at both ends in 5 cycles. Calculate the rotor positions in electrical degrees from the instant of fault occurrence up to 0.1 seconds at an interval of  $\Delta t = 0.05$  seconds. Note that the maximum deliverable power from the machine during the fault was 0.808 p.u. while that after clearing the fault was 1.5 p.u. (20)
  
2. (a) The transformers required in each of the following configurations have a secondary line to line voltage of 100 kV. Find the maximum DC voltage of the corresponding HVDC link formed in each case. (12)
  - i) 3- $\phi$  3 valve converters on both sides-of a monopoler link.
  - ii) 3- $\phi$  6 valve converters on both sides of a monopolar link
  - iii) 3- $\phi$  12 pulse converters on both sides of a bipoler link.
  - iv) Two sets of 12 pulse converters on both sides of a bipoler link
  
- (b) How can the current in a HVDC link be controlled? (8)
  
- (c) A HVDC line connects two AC systems via 6 pulse converters respectively connected to transformers with line to line secondary voltages of 100 kV and 90 kV. At the 100 kV end the converter operates with a delay angle of  $10^\circ$  and at the 90 kV end the converter operates with an extinction angle ( $\delta$ ) of  $15^\circ$ . The effective reactance per phase of each converter transformer is  $15\Omega$  and the loop resistance of the link is  $10\Omega$ . Determine the magnitude and direction of the DC current. Also find the percentage change required in the secondary voltage of the transformer which was originally at 90 kV so that the DC current becomes 800 Amps. (15)

**EEE 371**

3. (a) Using necessary derivations show that reactive power and voltage control are interrelated. (10)
- (b) Explain sub-synchronous resonance (SSR) phenomenon in static series compensation of long transmission lines. (8)
- (c) Why is the tap changing feature usually provided on the low tension side of a transformer? (5)
- (d) With diagrams explain the differences among a static compensator (STATCOM), a Static Synchronous Series Compensator (SSSC) and a Unified Power Flow Controller (UPFC). (12)
4. (a) What are the typical power quality events? Why not the disturbances like blackout, brownout and overvoltage are managed in the same way as the power quality events? (10)
- (b) Discuss the causes, effects and remedies of the event flicker. (10)
- (c) A single phase 2.5 km long cable has the following specifications. (15)
- Opening voltage: 11 kV line to neutral  
frequency : 50 Hz  
cable core dia : 20 mm  
internal sheath radius : 15 mm  
dielectric relative permittivity : 2.4  
loss angle : 0.031 radians.
- Determine its (i) capacitance in  $\mu\text{F}/\text{km}$ , (ii) total charging current, (iii) total VAR generated, (iv) total dielectric loss and (v) total equivalent insulation resistance in  $\text{M}\Omega$ .

**SECTION – B**

There are **FOUR** questions in this Section. Answer any **THREE**.

All the symbols have their usual meanings

5. (a) Derive the expression of internal inductance of an overhead conductor of unit length.. (12)
- (b) Derive the expression of total inductance of a single phase composite conductor line. (13)
- (c) The distances between the single strand conductors of an unsymmetrical 3-phase system are 6 m, 11 m and 9 m. The radius of each conductor is 10 cm and the system is operating at a frequency of 50 Hz. Find the inductive reactance per phase of the system for 10 km length of the line. (10)

**EEE 371**

6. (a) Derive the expression of capacitance of a 3-phase unsymmetrical transmission line considering the effect of earth. (17)  
 (b) What is transposition of conductors? Why is it used in unsymmetrical 3-phase lines? Derive the expression of capacitance of a 3-phase, 2-strand bundled unsymmetrical transmission line.
7. (a) Why does the frequency of a power system increase when the electrical output is less than the mechanical input and the frequency decrease when the electrical output is greater than mechanical input?  
 (b) Using rotor dynamics, derive the swing equation of an alternator. What is synchronizing power coefficient? (17)  
 (c) Derive the power-angle equation of a power system. (13)
8. (a) Derive and explain the equal area criterion using the single-line diagram shown in figure below, where a 3-phase fault occurs at point P and is cleared by circuit breaker A after a short period of time. (13)

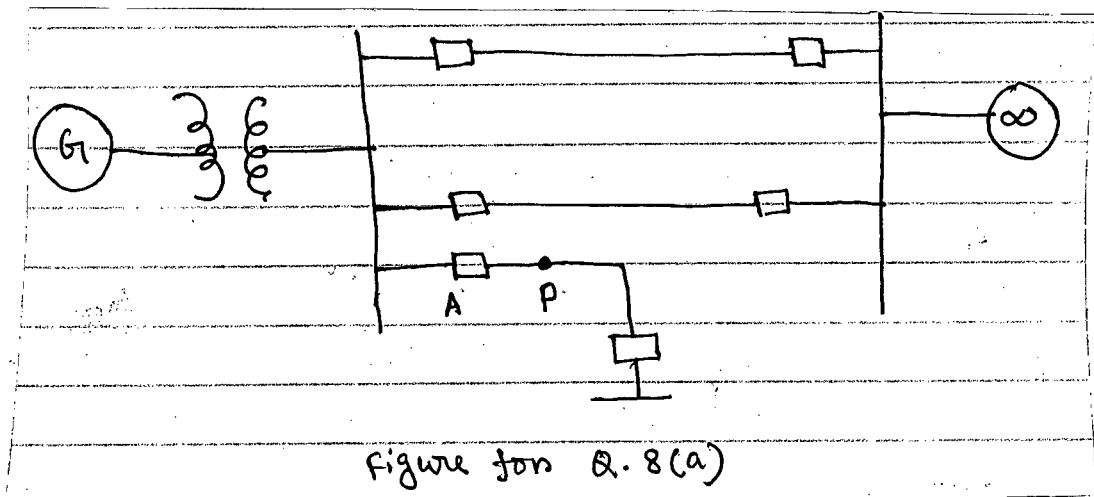

- (b) What is critical clearing angle? Derive the expressions of critical clearing angle and critical clearing time for the system described in 8(a). (12)
- (c) For the power system described in 8(a), mechanical power input,  $P_m = 0.45 P_{max}$ , where  $P_{max}$  is the maximum value of power-angle curve. Determine the critical clearing angle of the system. Now if  $P_{max} = 2.1$  p.u. and  $H = 5\text{MJ/MVA}$ , what is the critical clearing time of the system? (10)

-----

**SECTION – A**

There are **FOUR** questions in this Section. Answer any **THREE**.  
Answer in brief and to the point

1. (a) Mention the fundamental limitations of a telecommunication system. Explain in how many ways a communication channel can distort a signal, as it travels through the channel. Mention the two conditions for distortionless transmission of a signal. (15)
- (b) Write down the equation for thermal noise in an electrical circuit and from there derive an expression for the maximum noise power that may be transferred to a resistive termination. (12)
- (c) Calculate the maximum thermal noise (in watt) that a resistive termination in a standard band-limited telephone channel (300 Hz – 3400 Hz) will produce at an ambient temperature of 17°C. Also, express it in dBm. (6+2=8)
  
2. (a) Mention the purposes of performing modulation. Define amplitude modulation (AM) and modulation index for AM. Discuss the method of generating a DSB-SC signal. (11)
- (b) Suppose that an AM signal is represented by (12)

$$s(t) = 100 \cos(2\pi \times 10^4 t) + 50 \sin(2\pi \times 10^3 t) \times \cos(2\pi \times 10^4 t).$$

Draw the spectrum of the AM signal and determine

  - (i) modulation index
  - (ii) power in side-bands and
  - (iii) total power in the AM signal.
- (c) Why is DSB – FC signal transmitted in AM although it is less efficient? Draw a complete envelope – detector circuit for demodulating an AM signal and explain its operation with necessary signals at each point. (12)  
Will it work for an over-modulated signal?
  
3. (a) Define frequency modulation (FM). With necessary equations, distinguish between FM and PM. Suppose that you have an FM modulator. How can you use it to achieve PM? (10)
- (b) An FM transmitter is radiating 20 KW at a carrier frequency of 88 MHz with a carrier amplitude of  $A_c$  and modulation index  $\beta = 0.85$ . Determine (12)
  - (i) the carrier power
  - (ii) power in the side-bands

**EEE 309**

Contd ... Q. No. 3(b)

(iii) bandwidth of the FM signal using Carson's rule.

(c) What is a frequency discriminator? Draw the block diagram of a balanced frequency discriminator and explain its operation in brief. **(13)**

4. (a) Mention the main purpose of sampling an analog signal. For a sin wave input, show the gating pulse train and output of a sampler. **(12)**

Why is the sampled version called a PAM signal?

(b) Write down the equation for the output  $x_s(t)$  of a sampler, for an analog input signal  $x(t)$  and a periodic gating pulse train  $g(t)$ , with a duty cycle  $d = \frac{\tau}{T}$  and unity pulse amplitude. **(12)**

Using this equation, explain, how one can reconstruct the original analog signal  $x(t)$  from the sampled version of the signal  $x_s(t)$ .

(c) Compute the frequency components that will appear at the output of the two filters shown in Fig. for Q. No. 4(c) for the input signal **(11)**

$$x(t) = 5 \cos (1500 \pi t) - 0.4 \sin (5000 \pi t) + 0.12 \cos (10000 \pi t).$$

**SECTION - B**

There are **FOUR** questions in this Section. Answer any **THREE**.

The Symbols have their usual meanings

5. (a) Draw the block diagram of a PCM encoder. Derive the expression of signal-to-quantization noise ratio (SQNR). Explain the purpose of companding. **(15)**

(b) 1 volt (rms) sinusoidal message signal of frequency 10 KHz is given input to a PCM encoder. The required SQNR is 30 dB. Determine **(10)**

(i) How many bits are needed to encode each sample?

(ii) The output bit rate.

(c) Explain the purpose of DPCM with its functional block diagram. Compare DPCM and DM. Calculate the bit rate of a single channel DM that uses the standard band-limited telephone channel. **(10)**

6. (a) For an OOK signal, with a general block diagram, show the output of the synchronous detector if the locally generated Carrier is (i) not at the same frequency (ii) not synchronized in phase with the transmitted carrier. It is possible to detect a PSK signal by an envelope detector? Justify your answer. **(15)**

(b) With neat sketches, compare MSK and BPSK in terms of phase and power spectral density (PSD). **(8)**



**EEE 309**

Contd ... Q. No. 6

- (c) Write down Nyquist's maximum capacity theorem and Shannon's maximum capacity theorem. Using these theorems, compute the number of amplitude levels that can be correctly detected if one wants to send a signal through a standard band-limited telephone channel. Assume an SNR of 1023. Is such a choice of number of amplitude levels realizable in practice? Justify your answer. (12)
7. (a) With specific examples and figures, show that in a digital communication system, bit rate is doubled if 4-level modulation is adopted instead of 2-level (Binary) modulation. (7)
- (b) With general block diagram and sketches, derive the outputs of 4-PSK modulator and that of demodulator. What are the phase states of the carrier when the bit stream 1001011100 is applied to the 4-PSK modulator? If the recovered carrier at the demodulator is out of phase by  $\pi$  radians, what will be the output when the above 4-PSK carrier is applied to the demodulator? (18)
- (c) Draw the block diagram of a differential BPSK modulator. Summarize the encoder logic and rule of a differential BPSK. With a sketch of the phase states, explain 16 quadrature amplitude modulation (QAM). How the presence of amplitude modulation in QAM can be understood? (10)
8. (a) With an appropriate voltage-time diagram, derive the equations for information content (I) and system capacity (C) (10)
- (b) A 10-channel PCM system multiplexes 10-band-limited voice channels. The sampling rate is 8000 samples/sec. The encoder has 8 levels at the input and gives a 3-bit encoded digital pulse. Calculate the band width required at the output of the encoder. If an 8-bit encoder is used instead of the 3-bit encoder, and if the available channel bandwidth at the output of the encoder is 150 MHz, calculate how many voice channels can be multiplexed? (15)
- (c) Write short notes on any one of the following: (10)
- (i) 30 Channel and 24 channel PCM systems
  - (ii) Modem and data multiplexers.
  - (iii) TDMA and FDMA
-

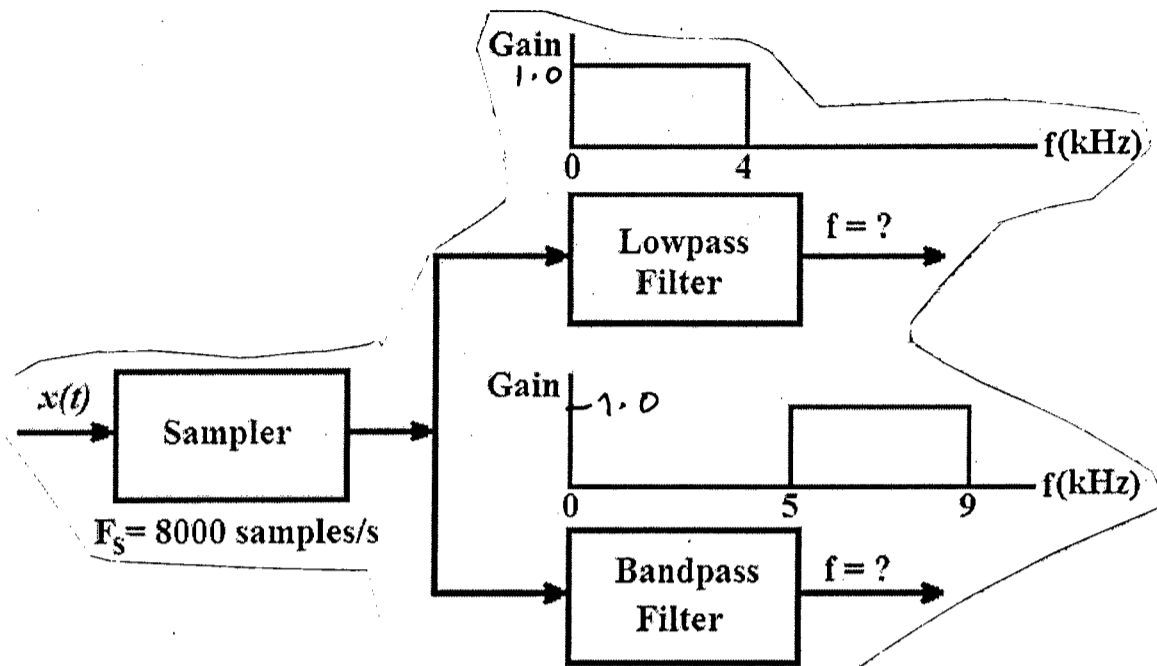

**Fig. for Q. No. 4(c)**

**SECTION – A**There are **FOUR** questions in this Section. Answer any **THREE**.

1. (a) (i) A memory location has a physical address 4A37H. If the segment number is 40FFH, compute the offset address and if the offset address is 123BH compute the segment number. (6)

(ii) Determine the physical address of a memory location given by 0A51:CD90H. (3)

(iii) Define (with example) any four of the following: (12)

(I) Immediate Addressing Mode

(II) Bus Interface Unit

(III) Paragraph Boundary

(IV) Single-flag Jump

(V) Divide Overflow

(b) Suppose A is an M×N byte array arranged in row major order. Write an assembly code to compute the transpose of the matrix A. Store the answer in an N×M byte array B arranged in row major order. For example, (14)

$$\text{if } A = \begin{bmatrix} 1 & 3 & 4 \\ 2 & 8 & 9 \\ 3 & 7 & 8 \end{bmatrix} \quad \text{then } B = \begin{bmatrix} 1 & 2 & 3 \\ 3 & 8 & 7 \\ 4 & 9 & 8 \end{bmatrix}$$

So A will be given as

A DB 1, 3, 4, 2, 8, 9, 3, 7, 8

The resulting B will be stored as

B DB 1, 2, 3, 3, 8, 7, 4, 9, 8

2. (a) In the code segment given in table, there are some syntax as well as logical errors. Find the errors and correct them with proper explanation. Provide the corrections in a tabular form given as

Line No.	Correct Instruction	Explanation
.	.	.
.	.	.
.	.	.
.	Answer to be written Here	Answer to be written here
.	.	.
.	.	.
.	.	.

**EEE 315**

**Contd . . . Q. No. 2(a)**

```
1      CODE SEGMENT
2          ASSUME CS:CODE, DS: CODE
3      LEA DX, 3N
4      MOV AL, [DX]
5      REPEAT: CALL SQR
6      ADD S&P, [S&P + BX]
7      DEC AL
8      JNZ REPEAT
9      HLT
10     SQR : PUSH AL
11     XOR AH, AH
12     MUL AL
13     MOV BX, 4
14     MOV [S&P + BX], AX
15     POP AL
16     RET
17
18     3N    DB    7
19     S&P   DB    ?
20
```

This code also computes the summation of a series. Write the series in mathematical form. (18)

(b) For the following declaration and instructions given mention the addressing modes of both the source and destination operand. If the instruction is illegal explain why it is illegal. (10)

WRD 1 DW OF38CH, 1259H, 3986H

BTE 1 DB OF3H, 53H, 1FH

(i) MOV AX, 32H

(ii) XCHG BTE1 + 2, WRD 1

(iii) MOV CX, WRD1 + 3

(iv) LEA SI, BTE 1 + 2

MOV DX, [ST] - 2

(v) ADD DH, [SI] 3

(vi) MOV [SI], 0F8H

(vii) INC WRD1 [BX] [BP]

(viii) PUSH 3618H

(ix) XCHG [BX], [DI]

(x) ADD BTE1, AX

**EEE 315**

**Contd . . . Q. No. 2**

(c) What will be the value of CF, SF, ZF, OF after executing each of the following instructions. (7)

- (i) MOV AL, 80H  
MOV BL, 0FFH  
IMUL BL
- (ii) MOV AL, - 15  
MOV CL, 4  
SHL AL, CL
- (iii) MOV AX, 0EF36H  
MOV CX, 01CF8H  
ADD AX, CX  
RCL AX  
AND AX, CX  
NOT CX.  
CMP CL, 03FH

3. (a) Design an 8086 system with two 2K×8 RAM, one 1K×8 RAM, two 2K×8 ROM and 8 I/O devices with each having 4 internal addresses. For the two 2K×8 RAM the address range will be 1C800H - 1CFFFH and 1D400H - 1DBFFH. For the one 1K×8 RAM the address range will be 1D000H- 1D3FFH. For the two 2K×8 ROM the address range will be 0F800H - 107FFH. For the I/O devices provision for a dedicated 1K memory mapped I/O should be kept in the range 01001H-01400H. 8 I/O devices must be shown each having 4 internal addresses in the address range 01100H - 0111FH. All the odd addressed data must be connected to the upper byte of the data bus and even addressed data must be connected to the lower byte of the data bus. Provide a neat connection diagram with proper labeling. (25)

(b) Sketch the timing diagram of the write cycle of 8086. (10)

4. (a) Suppose, a string is given in the memory. Write an assembly program that will change the case of the string. Use string instructions for accessing string elements. For example if the given string is 'BaNGLadeSH', the resulting string will be 'bAnglADEsh'. (15)

(b) Suppose, complex numbers are defined as

CMPLX	LABEL	WORD
REAL	DB	35
IMG	DB	23

Where, the declaration means 35 + 23\*j.

(j = imaginary unit). Write an assembly program that will multiply two complex numbers. (15)

**EEE 315**

**Contd . . . Q. No. 4**

(c) In the instruction

RET pop-value

What is the significance of 'pop-value'?

(5)

**SECTION – B**

There are **FOUR** questions in this Section. Answer any **THREE**.

5. (a) The owner of a newly established movie theatre has decided to employ a microprocessor based automatic door-control system in two gates. A feature of this system is to count the number of persons entering the theatre through the gates. For GATE 1, the maximum count is 1200 and for GATE 2, the maximum count is 1500. If the counts reach maximum for a gate, it should be closed. The system should run on an interrupt basis because the 8086 microprocessor has some more work to do.

(i) Draw the schematic of the system, with address decoding, using an interrupt controller (8259 IC), a timer (8254 IC) and decoder ICs (74LS138). The internal addresses for the interrupt controller and the timer should be FF20H, FF40H and F120H, F320H, F520H and F720H respectively. Assume that only the IR4 and IR5 inputs of the 8259 are available for use.

(16)

(ii) In which mode should you RUN the 8254? What should be the initial values? Let the interrupt types of the IR4 and IR5 inputs be type 44 and 45 respectively. Write a code in assembly language to initialize both the 8259 and 8254. Also write an ISR for IR4 at memory location 0000: 1200H and for IR5 at memory location 000: 1300H so that if interrupt occurs the timer would be stopped and two variables FLAG 1 and FLAG 2 will be set for GATE1 and GATE 2 respectively.

(19)

8259 Control Words:

	A <sub>0</sub>	D <sub>7</sub>	D <sub>6</sub>	D <sub>5</sub>	D <sub>4</sub>	D <sub>3</sub>	D <sub>2</sub>	D <sub>1</sub>	D <sub>0</sub>
ICW1	0	A <sub>7</sub>	A <sub>6</sub>	A <sub>5</sub>	1	LTIM	ADI	SINGL	IC4
ICW2	1	A <sub>15</sub> /T <sub>7</sub>	A <sub>14</sub> /T <sub>6</sub>	A <sub>13</sub> /T <sub>5</sub>	A <sub>12</sub> /T <sub>4</sub>	A <sub>11</sub> /T <sub>3</sub>	A <sub>10</sub>	A <sub>9</sub>	A <sub>8</sub>
ICW3	1	S <sub>7</sub>	S <sub>6</sub>	S <sub>5</sub>	S <sub>4</sub>	S <sub>3</sub>	S <sub>2</sub>	S <sub>1</sub>	S <sub>0</sub>
ICW4	1	0	0	0	SFNM	BUF	M/S	AEOI	μPM
OCW1	1	M <sub>7</sub>	M <sub>6</sub>	M <sub>5</sub>	M <sub>4</sub>	M <sub>3</sub>	M <sub>2</sub>	M <sub>1</sub>	M <sub>0</sub>
OCW2	0	R	SL	EOI	0	0	L <sub>2</sub>	L <sub>1</sub>	L <sub>0</sub>

8254 Control Words:

SC1	SC0	RW1	RW0	M2	M1	M0	BCD
-----	-----	-----	-----	----	----	----	-----

**EEE 315**

6. (a) Draw the connection diagram for connecting four seven segment displays in cascaded form with port A and port B of an 8255A-PPI (using proper buffering) so that the addresses of PORTA, PORTB, PORTC and the CWR are F008H, F00AH, F00CH and F00EH. It is given that the data and the address bus are already separated by means of latches and transceivers. Also connect two switches at PC0 and PC1 pins of 8255A. (13)

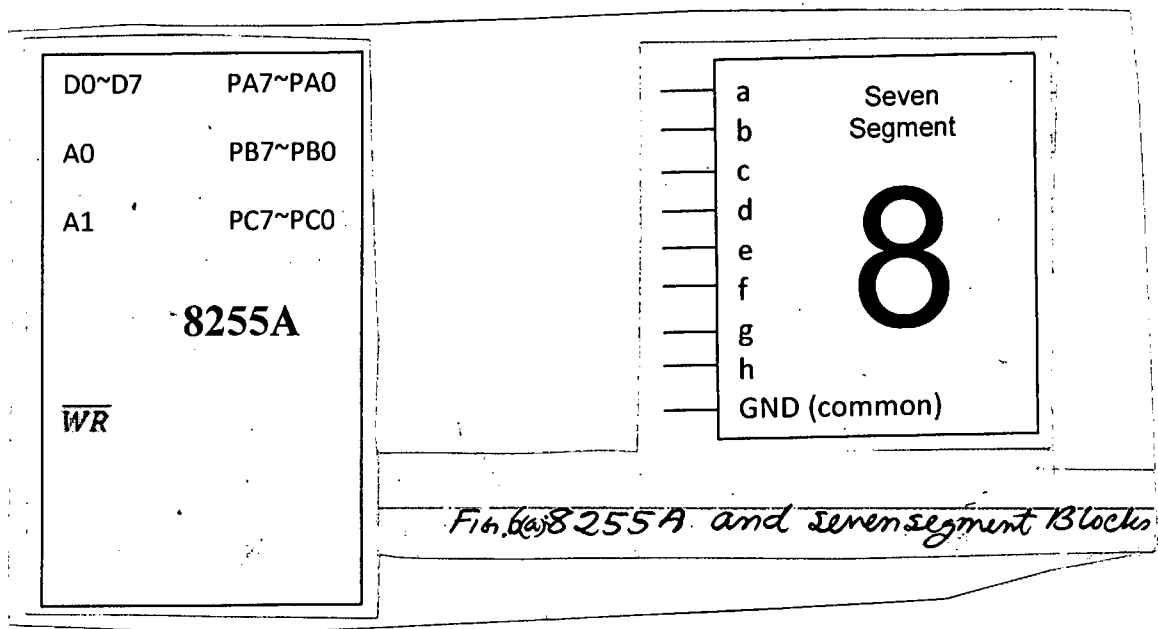

- (b) Initialize Ports A and B of 8255A as output and Port C as input by writing proper assembly codes. (10)

- (c) If the switch at PC0 is pressed, the four seven segment displays should show

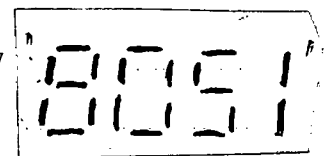

and if PC1 is pressed, it would show

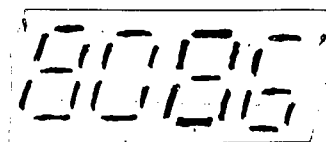

. If no switch is pressed it

would simply show

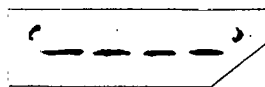

. Write an assembly code segment for

detecting a switch press using polling and for showing these outputs at the seven segment combinations. (12)

**EEE 315**

7. (a) Assume that an 8251 is connected at FF08H and FF0A addresses. Now write the initialization sequence in assembly language for the 8251 considering: baud rate factor of 64, 7bits/ character, even parity, 1 stop bit, transmit and receive interrupts enabled,  $\overline{DTR}$  and  $\overline{RTS}$  asserted, error flag reset. (10)
- (b) Show the sequence of instructions that can be used to poll this 8251A to determine when the receiver buffer has a character ready to read? How can you determine whether a character received by 8251 contains parity error? (7+5=12)
- (c) What frequency of transmit and receive clock will these 8251A require in order to send data at 2400 Bd? What other ways besides polling does the 8251A provide for determining when a character can be sent to the device for transmission? Describe the additional hardware connections required for this method. (5+8=13)

Table : MW CW and SW for 8251A IC.

MW	S2	S1	EP	PEN	L2	L1	B2	B1
CW	EH	IR	RTS	ER	SBRK	RxE	DTR	TxEN
SW	DSR	SYNDET	FE	OE	PE	TXE	RXRDY	TXRDY

8. (a) What are the major differences between SAP1 and SAP2 architecture? Explain the idea of Bidirectional Registers employed in SAP2. (10)
- (b) What is the function of presettable counter in SAP1 architecture? (5)
- (c) What instruction can be used to disable the INTR input of 8086? What is the significance of ICW3 for master and slave 8259 devices? Why is the INTR input automatically disabled as a part of the response to an INTR interrupt? (2+4+6=12)
- (d) Describe the double handshake data transfer with the help of simple timing diagram. (8)

-----



**SECTION – A**

There are **FOUR** questions in this Section. Answer any **THREE**.

If otherwise stated, symbols have their usual meanings.

The figures in the margin indicate full marks.

1. (a) The impulse response of a discrete-time LTI system is given by

$$h(n) = \begin{cases} 1 & \text{if } n = 0 \\ -1 & \text{if } n = 1 \\ 0 & \text{otherwise} \end{cases}$$

- (i) let  $x(n)$  and  $y(n)$  be the input and output, respectively of this system. Find the real numbers  $\alpha$ ,  $\beta$ , and  $\gamma$  such that  $y(n) = \alpha x(n+1) + \beta x(n) + \gamma x(n-1)$  (5)

- (ii) Is the system causal? Justify your answer. (3)

- (iii) Find the output  $y(n)$ , when the input of the system is given by, (7)

$$x(n) = \begin{cases} 1 & \text{if } n = -1 \\ 1 & \text{if } n = 0 \\ 0 & \text{otherwise} \end{cases}$$

- (b) There are two kinds of particles inside a nuclear reactor. In every second an  $\alpha$  particle splits into eight  $\beta$  particles and at the same time a  $\beta$  particle splits into an  $\alpha$  particle and two  $\beta$  particles.

- (i) Determine the difference equations that describe the number of particles in the reactor at a given second. (10)

- (ii) If there is a single  $\alpha$  particle in the reactor at time  $n = 0$  second, how many particles are there altogether at time  $n = 100$  second? (10)

2. (a) Design a causal discrete-time LTI system such that if the input is

$$x(n) = \left(\frac{1}{2}\right)^n u(n) - \left(\frac{1}{4}\right) \left(\frac{1}{2}\right)^{n-1} u(n-1) \text{ then the output is } y(n) = \left(\frac{1}{3}\right)^n u(n).$$

- (i) Determine the impulse response  $h(n)$  and the system function  $H(z)$ . (7)

- (ii) Sketch the pole-zero plots and ROC of  $H(z)$ , if the system is stable. (4)

- (iii) Find the difference equation that characterizes this system. (3)

- (iv) Realize the system with a minimum requirement of memory. (6)

**EEE 311**

(b) Consider the system shown in Fig. for Q. 2(b) for processing a continuous-time signal with a discrete-time system. (15)

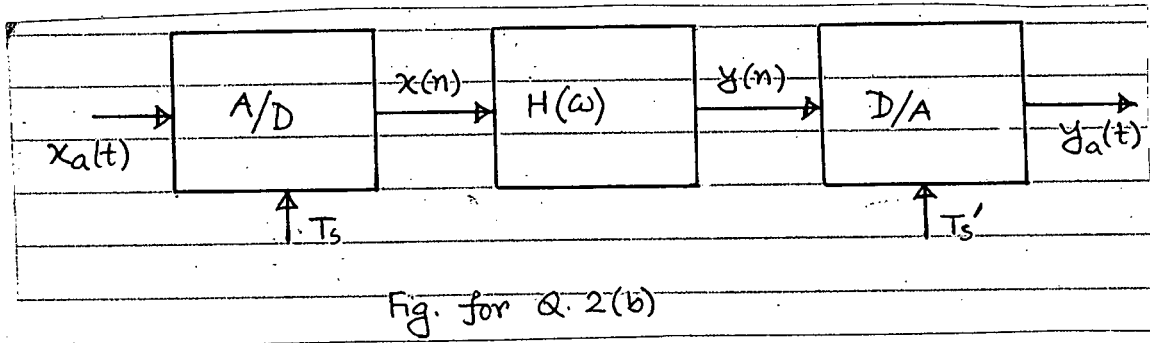

The frequency response of the discrete-time system is

$$H(e^{j\omega}) = \frac{2\left(\frac{1}{3} - e^{-j\omega}\right)}{\left(1 - \frac{1}{3}e^{-j\omega}\right)}$$

The sampling frequencies of the A/D and D/A converters are 2 kHz and 5 kHz, respectively. Find the output  $y_a(t)$  when the input signal  $x_a(t) = \sin\left(1000\pi t + \frac{\pi}{4}\right)$ .

3. (a) The system function of a communication channel is given by (10)

$$H(z) = (1 - 0.9e^{j0.4\pi}z^{-1})(1 - 0.9e^{-j0.4\pi}z^{-1})(1 - 1.5e^{j0.6\pi}z^{-1})(1 - 1.5e^{-j0.6\pi}z^{-1})$$

Determine the system function  $H_c(z)$  of a causal and stable compensating system so that the cascaded interconnection of the two systems has a flat magnitude response.

(b) The discrete time system shown in Fig. for Q. 3(b) is characterized by the following input-output relationships:

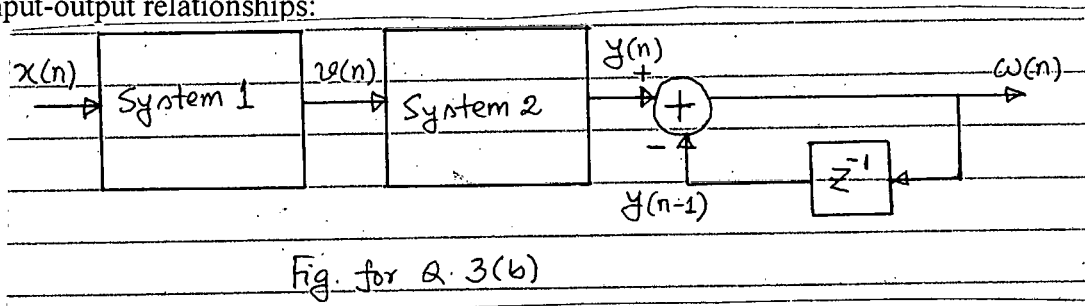

System 1:  $v(n) = x(n-1) + x(n) + x(n+1)$

System 2:  $y(n) = v(n-1) + v(n) + v(n+1)$

Consider that the input to this system is the periodic signal  $x(n) = \sum_{k=-\infty}^{k=\infty} \delta(n-6k)$

(i) Determine the Fourier series coefficients of  $x(n)$  denoted as  $a_k$  for all  $k$ . (5)

(ii) Determine and plot several periods of  $y(n)$  and  $w(n)$ . (8)

(iii) Determine the Fourier series coefficients of  $y(n)$  denoted as  $b_k$  for all  $k$ . (8)

(iv) Determine the Fourier series coefficients of  $w(n)$  denoted as  $C_k$  in terms of  $b_k$  for all  $k$ . (4)

**EEE 311**

4. (a) Let  $X_m(\omega)$  ( $m = 1, 2, 3$ ) be the DTFT of the discrete-time signal  $x_m(n)$ . If  $x_3(n) = x_1(n)$

$x_2(n)$ , then prove that  $X_3(\omega) = \frac{1}{2\pi} \int_{-\pi}^{\pi} X_1(\lambda)X_2(\omega - \lambda)d\lambda$  (7)

(b) Consider a discrete-time LTI system described by the following difference equation:

$$y(n) = -x(n + 1) + 2x(n) - x(n - 1)$$

(i) Find and plot the magnitude of the frequency response function, i.e.,  $|H(\omega)|$ . (8)

(ii) A discrete-time input signal  $x(n)$  is obtained by sampling an analog signal (8)

$x_a(t) = 1 + \cos 3t + 2 \cos\left(6t + \frac{\pi}{4}\right)$  with a sampling period  $T_s = \frac{\pi}{4}$ . Does any aliasing

happen? Plot the magnitude spectrum of the DTFT of the sampled signal  $x(n)$  denoted as  $|X(\omega)|$ .

(iii) Plot the magnitude spectrum of the corresponding sampled output signal  $y(n)$  denoted as  $|Y(\omega)|$ . (6)

(iv) Determine the numerical value of  $\sum_{n=-\infty}^{n=\infty} |y(n)|^2$  (6)

**SECTION - B**

There are **FOUR** questions in this Section. Answer any **THREE**.

The questions are of equal value.

5. (a) An LTI system with frequency response  $H(\omega)$  is excited with the periodic input

$$x(n) = \sum_{k=-\infty}^{\infty} \delta(n - kN)$$

If  $Y(k)$  is the  $N$ -point DFT of  $y(n)$ ,  $0 \leq n \leq N - 1$ , then find the relation between  $Y(k)$  and  $H(\omega)$ .

(b) Describe overlap-add method of filtering of long data sequence using DFT. Discuss the implications of finite data record in frequency analysis using DFT.

6. (a) Define DFT of an arbitrary sequence  $x(n)$  and find its relations with Fourier series coefficients and also with  $Z$ -transform.

(b) Show that circular convolution between 2-sequences is equivalent to multiplication of their DFTs. Find  $N$ -point circular convolution of the sequences,

$$x_1(n) = \sin \frac{2\pi}{N} n \quad \text{and} \quad x_2(n) = \cos \frac{2\pi}{N} n \quad \text{for} \quad 0 \leq n \leq N - 1$$

**EEE 311**

7. (a) Discuss windowing in calculating FIR filter coefficients. Using window method, find the first 5 coefficients of an FIR BPF to meet the following specifications:

Pass band : 150 - 250 Hz

Transition width : 50 Hz

Stop band attenuation : 60 dB

Sampling frequency : 1 kHz

(b) Describe the alternation theorem to determine FIR filter coefficients by optimum equiripple method.

8. (a) "Analog filters can be transformed into IIR type more easily than into FIR ones"-

Explain. Convert a simple analog filter with  $H(S) = \frac{C}{S-p}$  into equivalent IIR digital

filter by impulse invariant method.

(b) Deduce the relations between s - and Z - parameters to convert an analog filter into its equivalent IIR digital filter by bilinear Z transformation method. Convert the analog filter

with transfer function  $H(s) = \frac{s+0.1}{(s+0.1)^2+16}$  into digital IIR filter using BZT method.

The digital filter is to have a resonant frequency of  $\omega_r = \pi/2$

-----

BANGLADESH UNIVERSITY OF ENGINEERING AND TECHNOLOGY, DHAKA

L-3/T-1 B. Sc. Engineering Examinations 2009-2010

Sub : **EEE 307** (Electrical Properties of Materials)

Full Marks : 210

Time : 3 Hours

The figures in the margin indicate full marks.

USE SEPARATE SCRIPTS FOR EACH SECTION

**SECTION – A**There are **FOUR** questions in this Section. Answer any **THREE**.

1. (a) Define 'Lattice' and 'Basis'. Draw reduced sphere representation of FCC, BCC and HCP crystal structure. Define 'Atomic Packing Factor'. (15)
- (b) Consider the FCC unit cell of the copper crystal. (20)
  - (i) How many atoms are there per unit cell?
  - (ii) If  $R$  is the radius of the  $C_u$  atom, show that the lattice parameter  $a$  is given by  $a = R2\sqrt{2}$ .
  - (iii) Calculate the atomic packing factor (APF).
  - (iv) If the lattice parameter  $a$  is given as 0.362 nm, calculate the planar concentration for (111) plane.
  
2. (a) State and discuss 'Fourier's law' of heat conduction. How is the Ohm's law of electrical conduction is related to the 'Fourier's law' of heat conduction in metals? (12)
- (b) Discuss 'Matthiessen's rule'. Define 'Temperature coefficient of Resistivity' (TCR). (13)
- (c) Consider a 40 W, 120 V incandescent light bulb. The Tungsten filament is 0.381 m long and has a diameter of 33  $\mu\text{m}$ . Its resistivity at room temperature is  $5.51 \times 10^{-8} \Omega\text{-m}$ . Given that the resistivity of the tungsten filament varies at  $T^{1.2}$  ( $T$  = temperature), estimate the temperature of the bulb at steady state condition when it is operated at the rated voltage. Consider that the room temperature is 300° K. (10)
  
3. (a) What is photoelectric effect? Discuss the results from the photoelectric experiments and its interpretations given by Einstein. (20)
- (b) In the photoelectric experiment, green light, with a wavelength of 522 nm, is the longest wavelength radiation that can cause the photoemission of electrons from a clean sodium surface. (15)
  - (i) What is the work function of sodium, in electron-volts?
  - (ii) If UV radiation of wave length 250 nm is incident to the sodium surface, what will be the kinetic energy of photoemitted electrons in electron-volts?
  - (iii) Consider that the UV light of wavelength 250 nm has an intensity of 20 mW  $\text{cm}^{-2}$ . If the emitted electrons are collected by applying a positive bias to the opposite electrode, what will be the photoelectric current density?

**EEE 307**

4. (a) Using Linear Combination of Atomic Orbitals (LCAO) method explain why hydrogen can form molecule ( $H_2$ ) but helium can not. (12)
- (b) By solving schrodinger's equation for an infinite potential well, derive the expression for wavefunctions and show it graphically. (15)
- (c) Discuss Heisenberg's uncertainty principle. (8)

**SECTION – B**

There are **FOUR** questions in this Section. Answer any **THREE**.

5. (a) Derive Clausius-Mossotti equation. (18)
- (b) Classify magnetic materials. Briefly discuss the main characteristics of each type. (17)
6. (a) What is piezoelectricity? Write three applications of piezoelectric materials. (10)
- (b) For a crystal structure show that effective mass
- $$m^* = \frac{1}{\frac{1}{\hbar^2} \cdot \frac{d^2 E}{dk^2}}; \text{ where the symbols have their usual meanings.} \quad (15)$$
- (c) If  $E = 1 \times 10^{-36} k^2 + 1.2 \times 10^{-18} k + 0.002$ , find the value of  $m^*$ . (10)
7. (a) What is super conductivity? Briefly describe the characteristics of Type I and Type II superconductors. (17)
- (b) Show that in an infinite potential well the density of states per unit volume at a particular energy level is proportional to square root of that energy. (18)
8. (a) What is dielectric of loss? Discuss the effect of frequency on dielectric loss. Find the expression of loss per unit volume. (18)
- (b) Water has a static relative dielectric constant of 80. Individual molecule has a permanent dipole of  $6 \times 10^{-30}$  Coul-m with a relaxation time of  $10 \times 10^{-9}$  s. Calculate the dielectric loss per unit volume with an electric field of 1 kV/cm at 3 GHz. (17)
-