

**SECTION - A**

There are **FOUR** questions in this Section. Answer any **THREE** questions.

1. (a) Derive the expression for impedance, instantaneous power, real power, reactive power, average power and volt-ampere of a series RLC circuit. Also draw the necessary waveshapes. (20)
- (b) Find the value of L of the circuit shown in Fig. 1(b). Also draw the corresponding phasor diagram. (15)

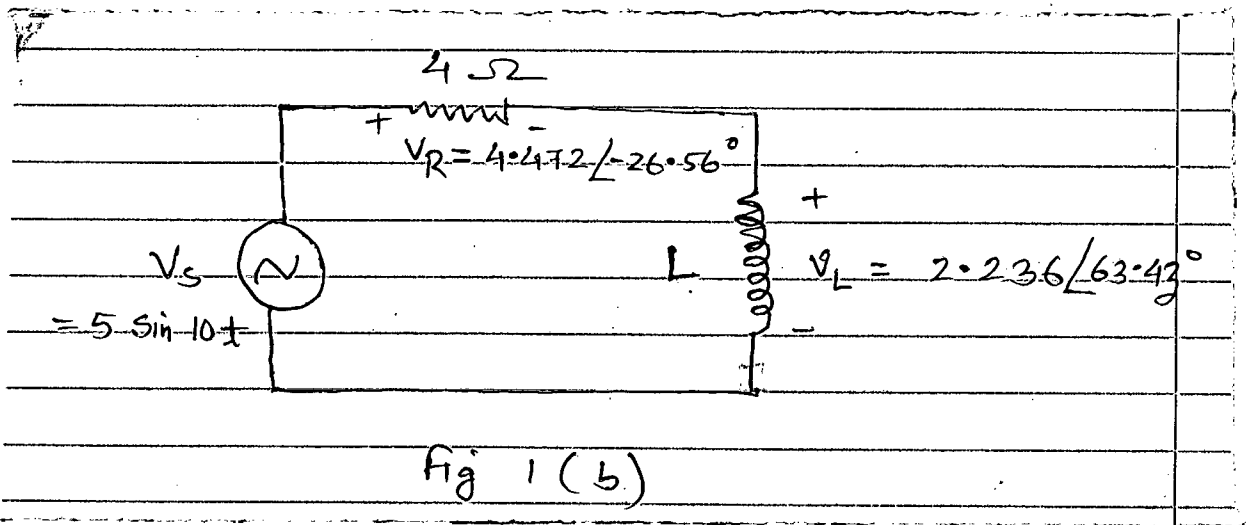

2. (a) Determine the load impedance  $Z_L$  that maximizes the average power drawn from the circuit of Fig. 2(a). What is the maximum average power? (17)

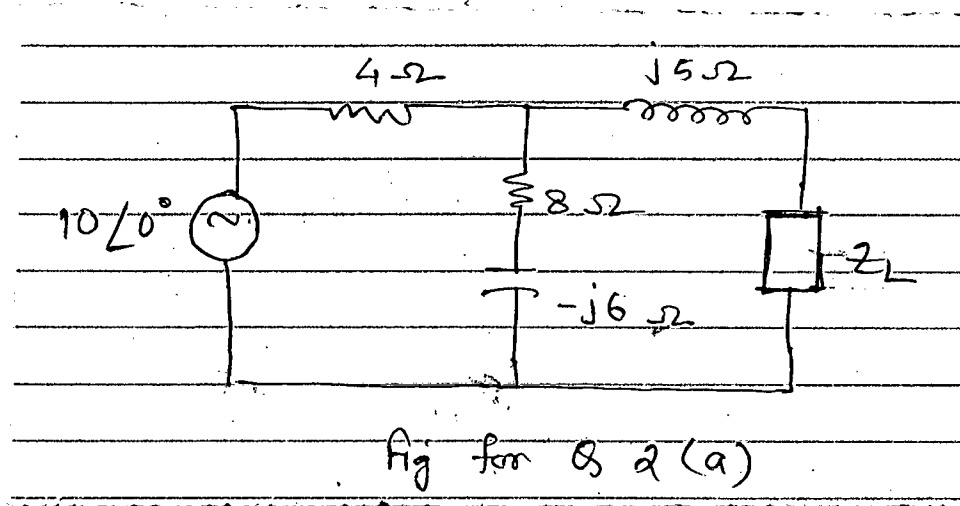

**EEE 155**

**Contd ... Q. No. 2**

(b) A load Z draws 12 kVA at a lagging power factor of 0.856 from a 120 V (rms) sinusoidal source. Calculate: (18)

(i) Average and reactive powers delivered to the load (ii) peak current (iii) load impedance

3. (a) Find the RMS value of the wave shown in Fig. for Q. 3(a), if the current is passed through a resistor of  $10 \Omega$ , find the average power absorbed by the resistor. (18)

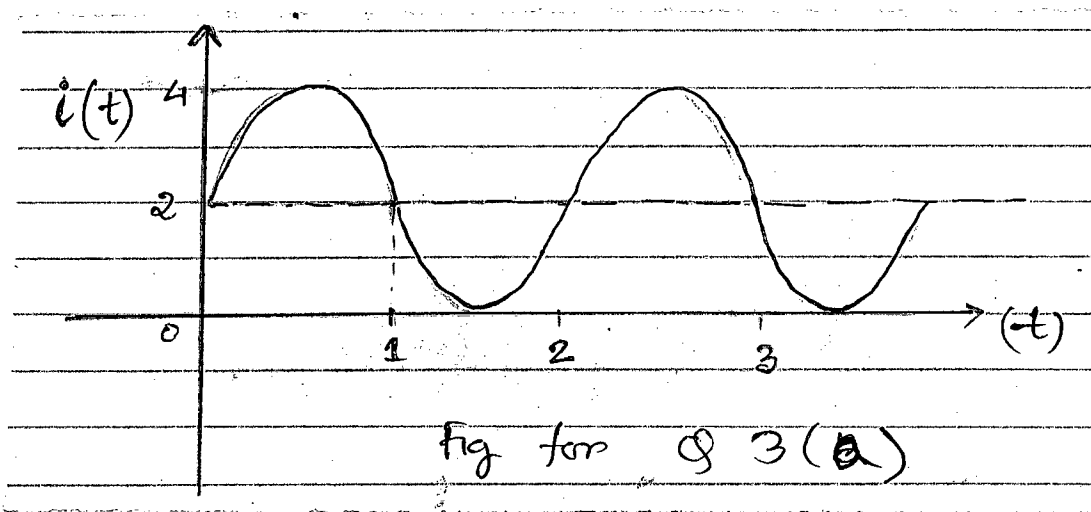

(b) Find  $v_0$  in the circuit in Fig. for Q. 3(b). (17)

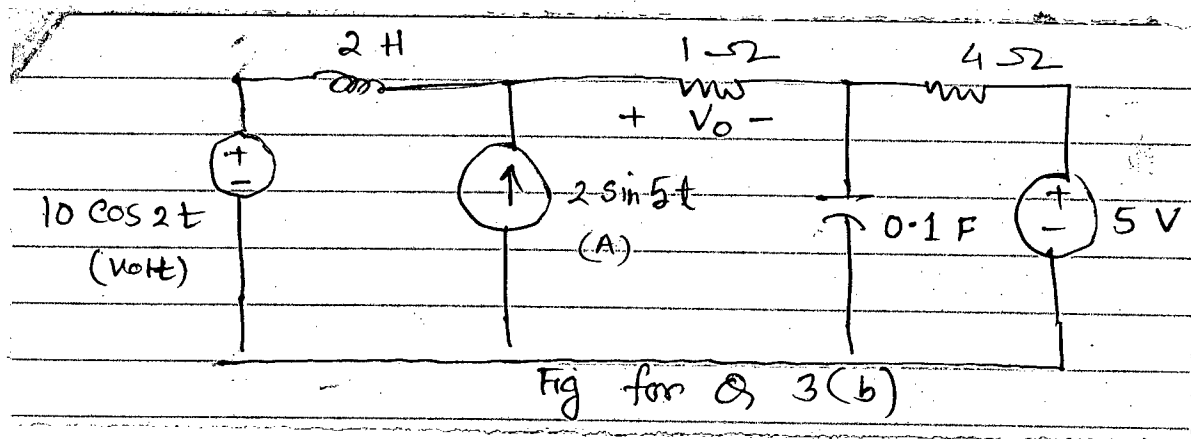

4. (a) When connected to a 120 V (RMS), 60 Hz power line, a load absorbs 4 kW at a lagging power factor of 0.8. Find the value of capacitance necessary to raise the p.f to 0.95. How will you connect the capacitance? Also draw corresponding phasor diagram and power triangle. (18)

(b) Find the value of I required to establish a magnetic flux of  $\Phi = 0.75 \times 10^{-4}$  Wb in the circuit shown in Fig. for Q. 4(b). (17)

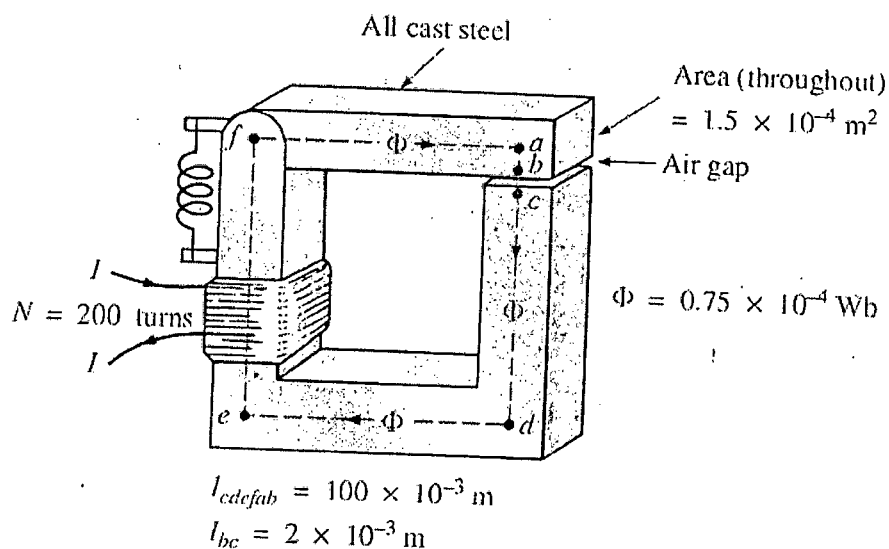
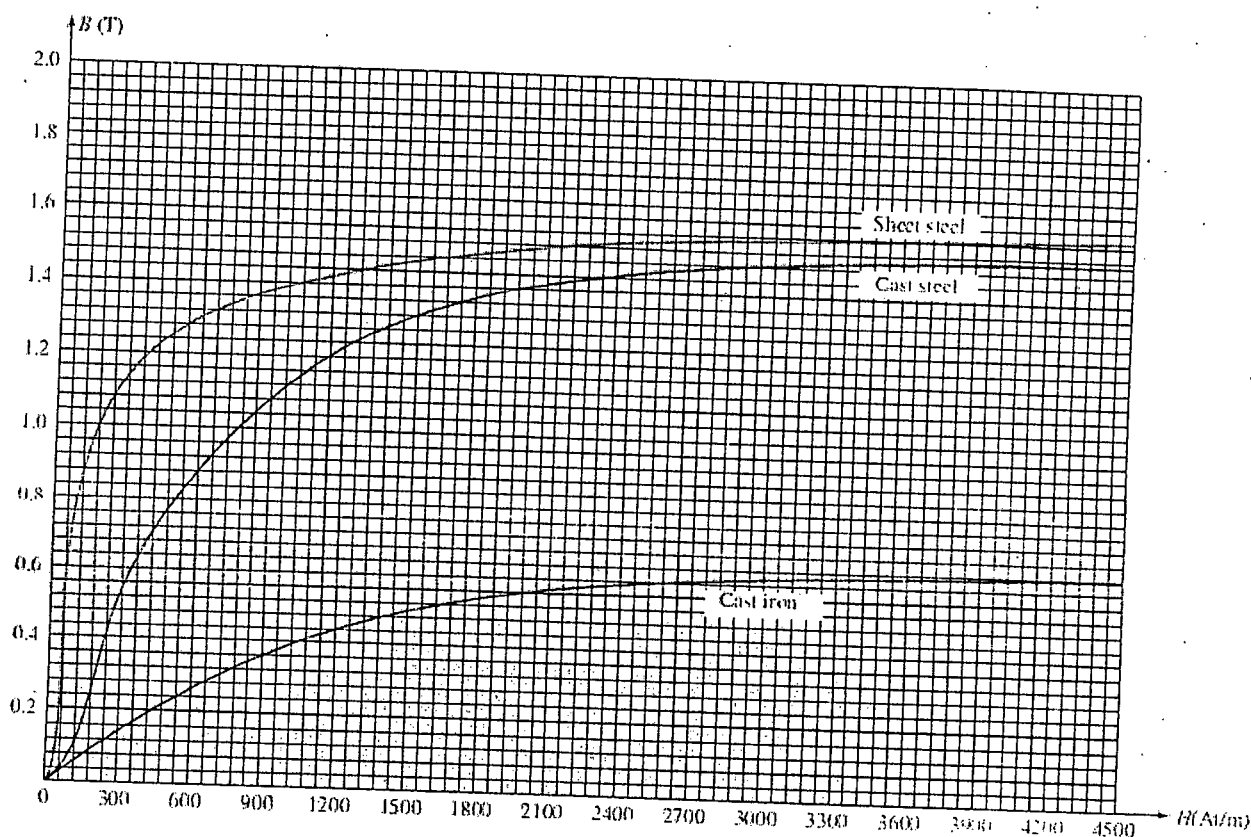

Fig for Q 4(b)



B-H curve for question no 4(b)

**EEE 155**

**SECTION – B**

There are **FOUR** questions in this Section. Answer any **THREE** questions.

5. (a) Fig. for Q. 5(a) shows the current through and voltage across a device. (20)
- (i) Sketch the power delivered to the device for  $t > 0$ .
- (ii) Find the total energy absorbed by the device for period of  $0 < t < 4$  sec.

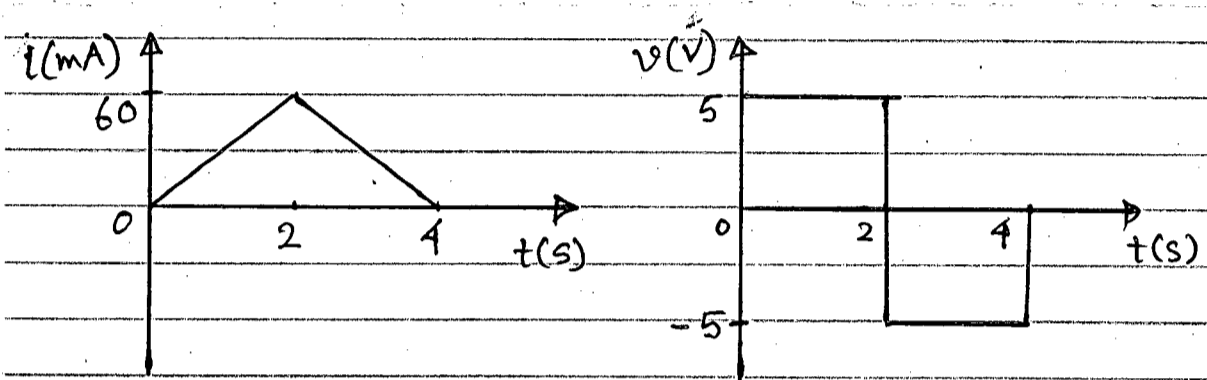

Fig. for Q. 5(a)

- (b) A battery may be rated in ampere-hours (Ah). A lead acid battery is rated at 160 Ah.
- (i) What is the maximum current it can supply for 40 h? (15)
- (ii) How many days will it last if it is discharged at 1 mA?

6. (a) Find  $V_{AB}$  and  $I$  in the circuit shown in Fig. for Q. 6(a). (20)

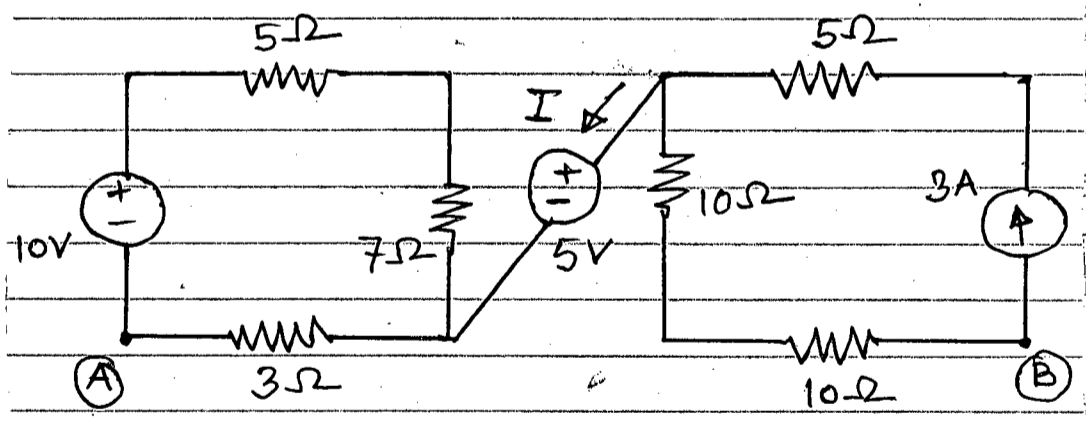

Fig. for Q. 6(a)

- (b) Calculate the equivalent resistance  $R_{ab}$  at terminals a-b for the circuit shown in Fig. for Q. 6(b) (15)

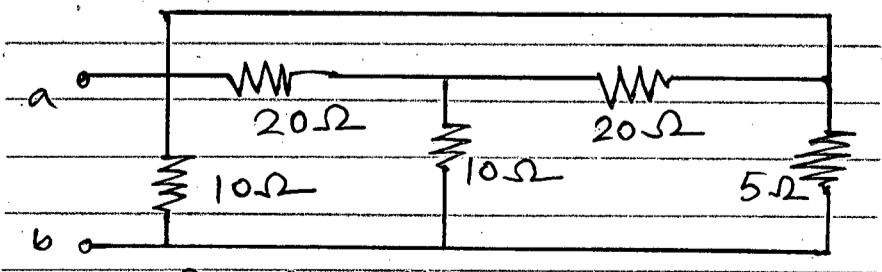

Fig. for Q. 6(b)

**EEE 155**

7. (a) Find  $v_0$  and  $i_0$  in the circuit shown in Fig. for Q. 7(a).

(17)

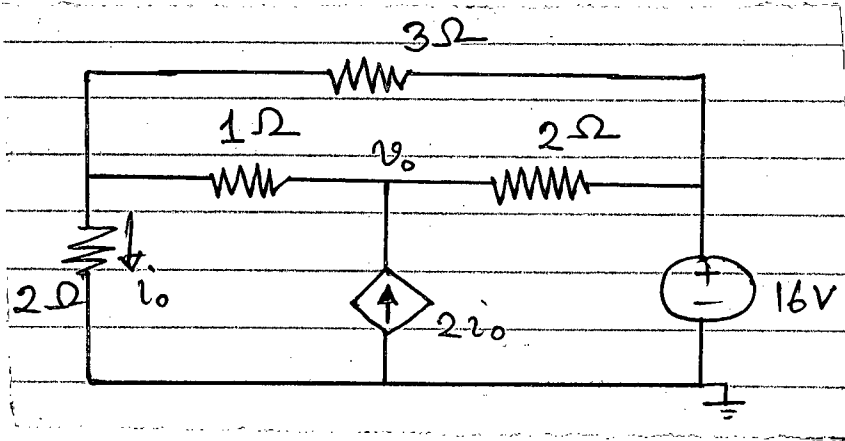

fig. for Q. 7(a)

(b) For the circuit shown in Fig. for Q. 7(b), find the terminal voltage  $V_{ab}$  using the principle of superposition.

(18)

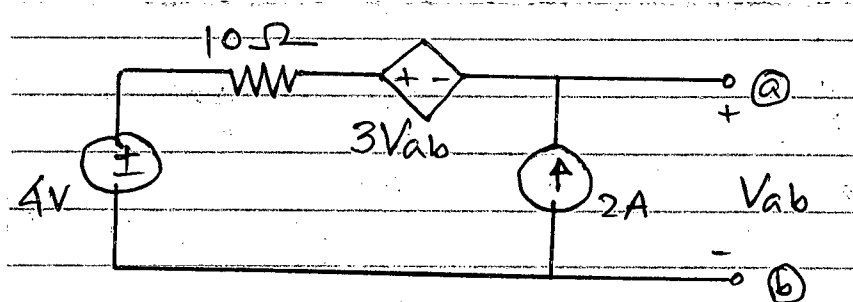

fig. for Q. 7(b)

8. (a) For the transistor model shown in Fig. for Q. 8(a), obtain the Thevenin's equivalent at terminals a-b.

(17)

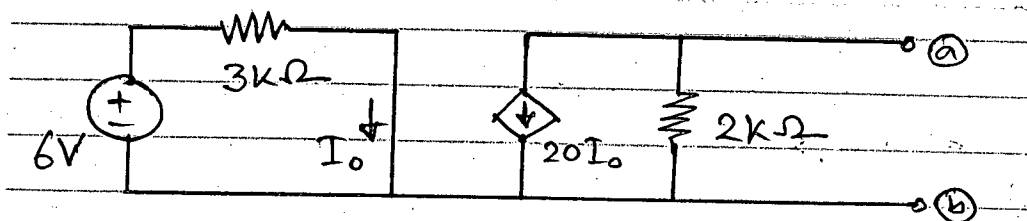

fig. for Q. 8(a)

(b) Compute the value of  $R$  that results in maximum power transfer to the  $10\Omega$  resistor shown in circuit of Fig. for Q. 8(b). Also find the maximum power.

(18)

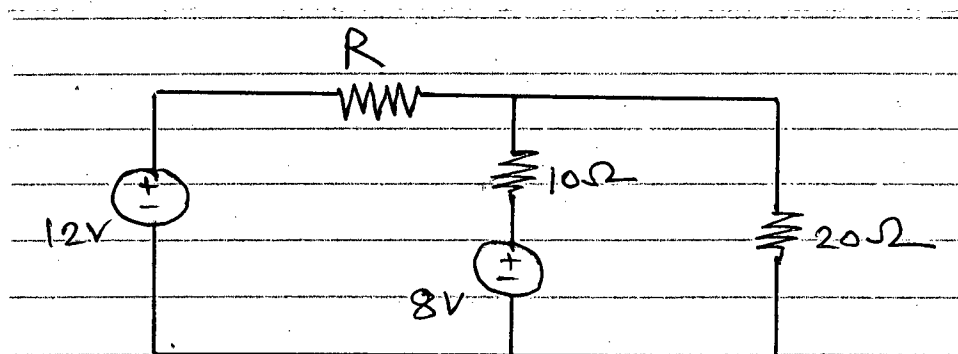

fig. for Q. 8(b)

**SECTION – A**

There are **FOUR** questions in this section. Answer any **THREE** questions.

Symbols indicate their usual meaning. Assume any missing data.

1. (a) Automobile *A* is travelling along a straight highway, while *B* is moving along a circular exit ramp of 150-m radius. The speed of *A* is being increased at the rate of  $1.5 \text{ m/s}^2$  and the speed of *B* is being decreased at the rate of  $0.9 \text{ m/s}^2$ . For the position shown in Fig. for Q. 1(a), determine the acceleration of *A* relative to *B*. (18)

- (b) A 160-lb pilot flies a small plane in a vertical loop of 500-ft radius as shown in Fig. for Q. 1(b). Determine the speed of the plane at points *A* and *B*, knowing that at point *A* the pilot experiences weightlessness and that at point *B* the pilot's apparent weight is 550 lb. (17)

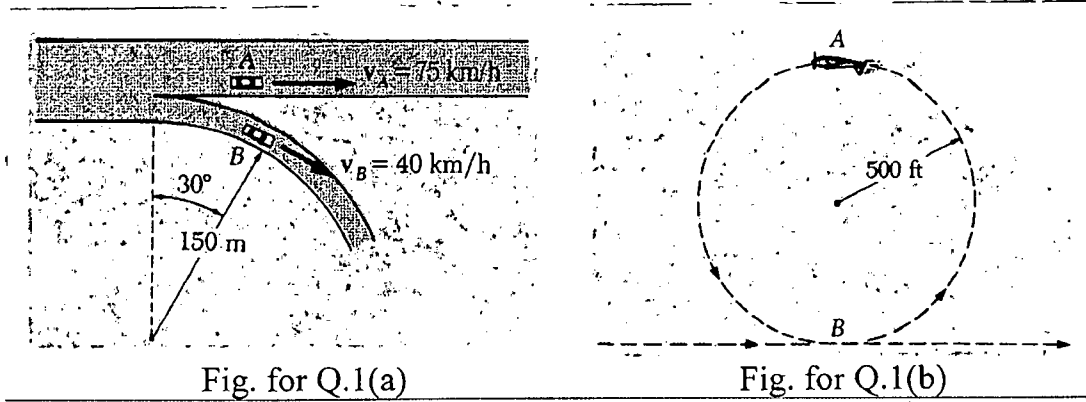

2. (a) Packages are thrown down an incline at *A* with a velocity of 1 m/s as shown in Fig. for Q. 2(a). The packages slide along the surface *ABC* to a conveyor belt which moves with a velocity of 2 m/s. Knowing that  $\mu_k = 0.25$  between the packages and the surface *ABC*, determine the distance *d* if the packages are to arrive at *C* with a velocity of 2 m/s. (17)

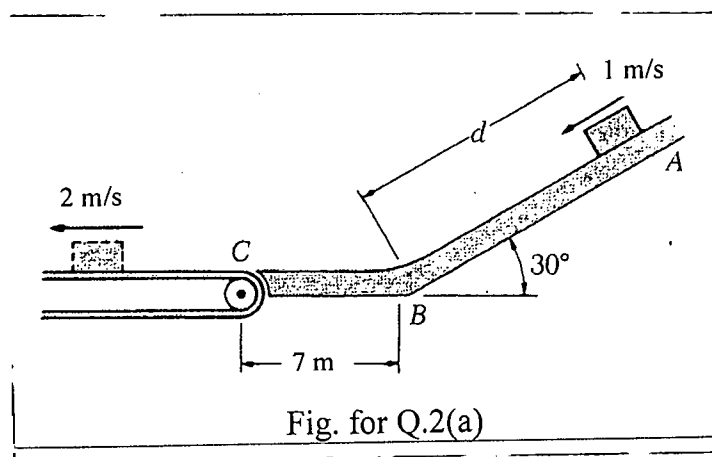

**ME 141/CHE**

**Contd ... Q. No. 2**

(b) A 750-g collar may slide along the horizontal rod as shown in Fig. for Q. 2(b). It is attached to an elastic cord with an undeformed length of 300 mm and a spring constant of 150 N/m. Knowing that the collar is released from rest at *A* and neglecting friction, determine the speed of the collar at *E*. (18)

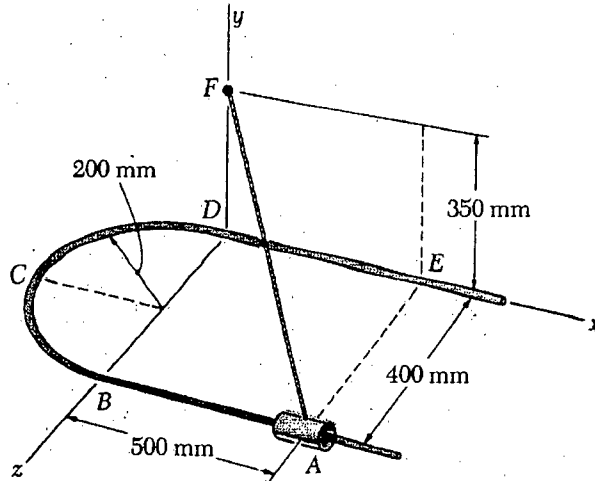

Fig. for Q.2(b)

3. (a) An 18-kg cannon ball and a 12-kg cannonball are chained together and fired horizontally with a velocity of 165 m/s from the top of a 15-m wall as shown in Fig. for Q. 3(a). The chain breaks during the flight of the cannon balls and the 12-kg cannonball strikes the ground at  $t = 1.5$  s, at a distance of 240 m from the foot of the wall, and 7 m to the right of the line of fire. Determine the position of the other cannon ball at that instant. Neglect the resistance of the air. (17)

(b) Knowing that at the instant shown in Fig. for Q. 3(b) the angular velocity of rod *BE* is 4 rad/s counterclockwise, determine (i) the angular velocity of rod *AD*, (ii) the velocity of collar *D*. (18)

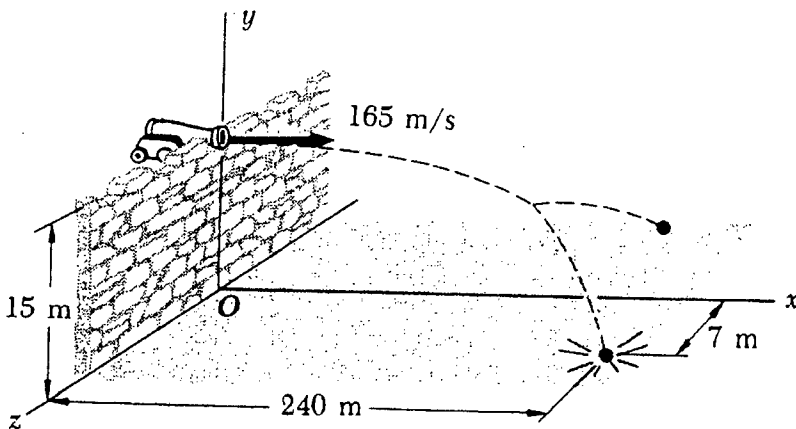

Fig. for Q.3(a)

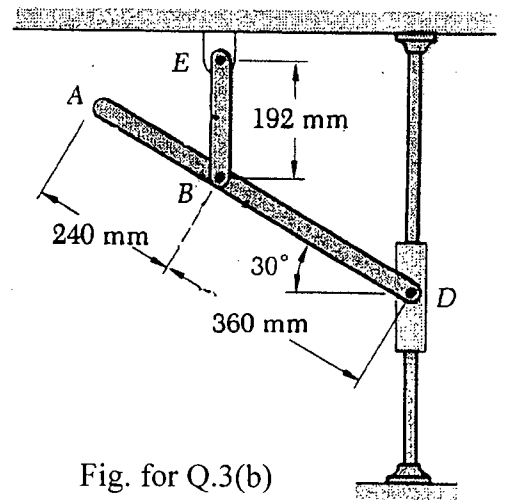

Fig. for Q.3(b)

**ME 141/CHE**

4. (a) A pulley and two loads are connected by inextensible cords as shown in Fig. for Q. 4(a). Load *A* has a constant acceleration of  $300 \text{ mm/s}^2$  and an initial velocity of  $240 \text{ mm/s}$ , both directed upward. Determine (i) the velocity and position of load *B* after 3 s, (ii) the acceleration of Point *D* on the rim of the pulley at  $t = 0$ . (17)

- (b) A 20- kg cabinet is mounted on casters that allow it to move freely ( $\mu = 0$ ) on the floor. If a 100-N force is applied as shown in Fig. for Q. 4(b), determine (i) the acceleration of the cabinet, (ii) the range of values of  $h$  for which the cabinet will not tip. (18)

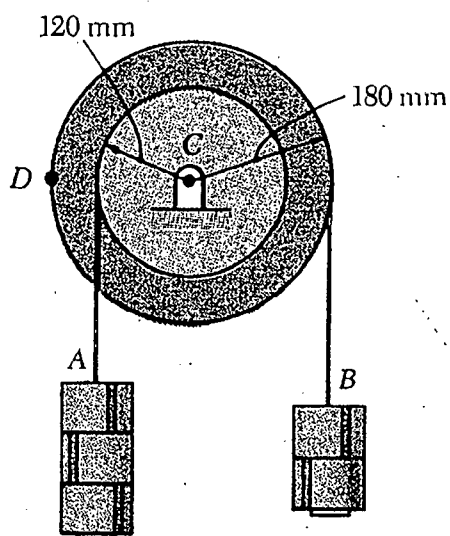

Fig. for Q.4(a)

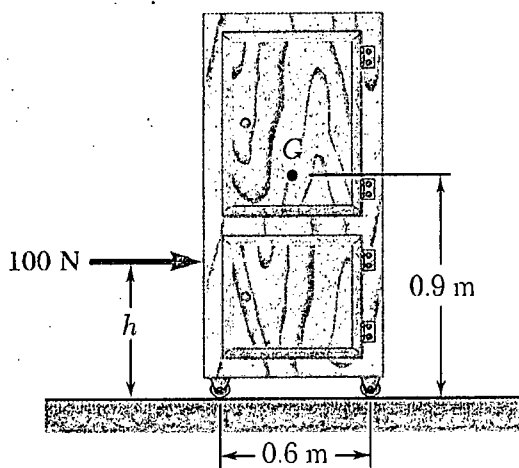

Fig. for Q.4(b)

**SECTION – B**

There are **FOUR** questions in this Section. Answer any **THREE**.

5. (a) Two cables are tied together at C and loaded as shown in Fig. 5(a) Knowing that  $P = 500 \text{ N}$  and  $\alpha = 60^\circ$ , determine the tension in AC and BC. (17)

- (b) Rod AB is held in place by the cord AC as shown in Fig. 5(b). Knowing that the tension in the cord is  $1200 \text{ N}$  and that  $c = 0.5 \text{ m}$ , determine the moment about B of the force exerted by the cord at A. (18)

6. (a) A vertical load  $P$  is applied at end B of rod BC as shown in Fig. 6(a). Neglecting the weight of the rod, (i) express the angle  $\theta$  corresponding to the equilibrium position in terms of  $P$ ,  $l$ , and the counter weight  $W$ . (ii) Determine the value of  $\theta$  corresponding to equilibrium if  $P = 2W$ . (15)

- (b) Determine the location of the centroid of the half right circular cone shown in Fig. 6(b). (20)



**ME 141/CHE**

7. (a) Determine the force in members FG and FH of the truss, shown in Fig. 7(a) when  $P = 35 \text{ kN}$ . (15)

(b) The hydraulic cylinder CF, which partially controls the position of rod DE, has been locked in the position shown in Fig. 7(b). Knowing that  $\theta = 60^\circ$ , determine (i) the force P for which the tension in the link AB is 410 N, and (ii) the corresponding force exerted on member BCD at point C. (20)

8. (a) A slender rod of length L is lodged between peg C and the vertical wall and supports a load P at end A as shown in Fig. 8(a). Knowing that  $\theta = 35^\circ$ , and the coefficient of static friction is 0.20 at both B and C, find the range of values of the ratio L/a for which equilibrium is maintained. (17)

(b) Determine the moments of inertia of the shaded area shown in Fig. 8(b) with respect to x axis when  $a = 20 \text{ mm}$ . (18)

-----

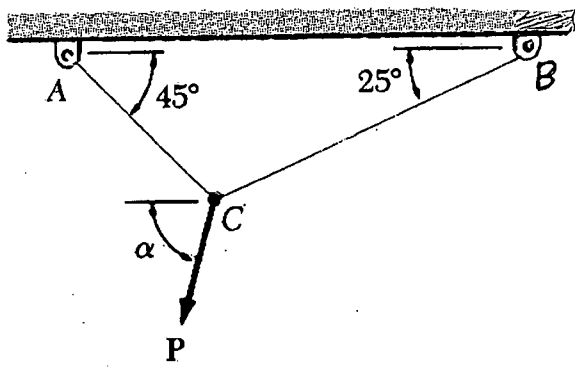

Fig. 5(a)

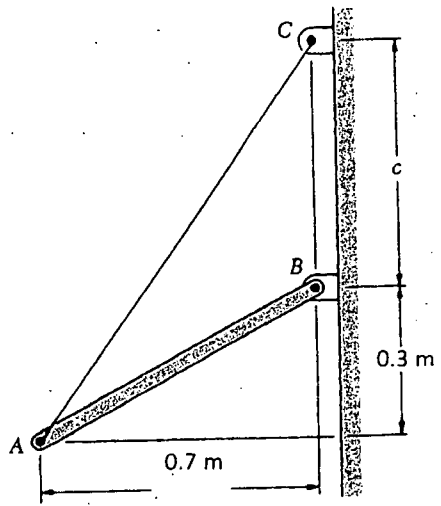

Fig. 5(b)

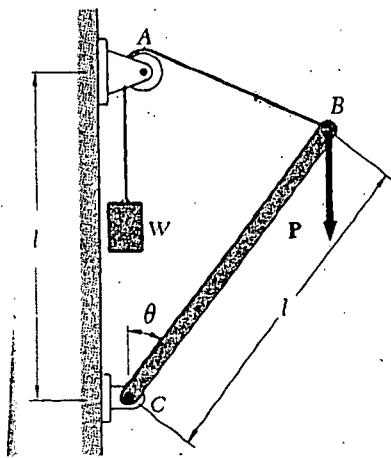

Fig. 6(a)

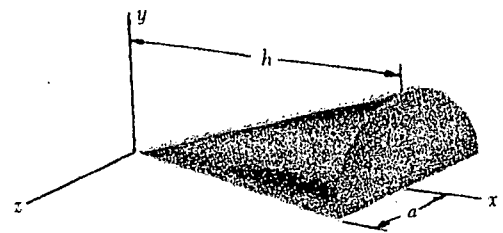

Fig. 6(b)

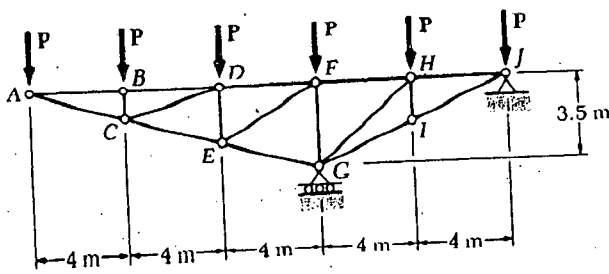

Fig. 7(a)

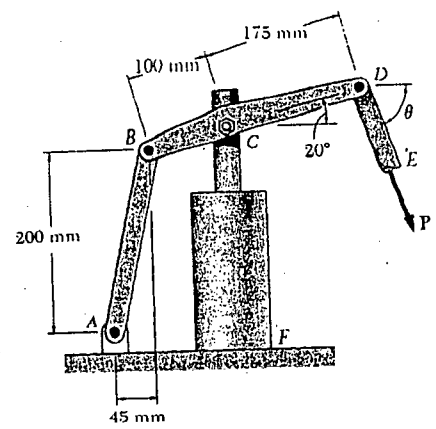

Fig. 7(b)

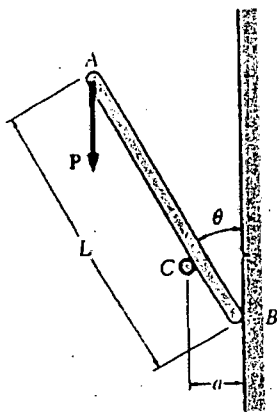

Fig. 8(a)

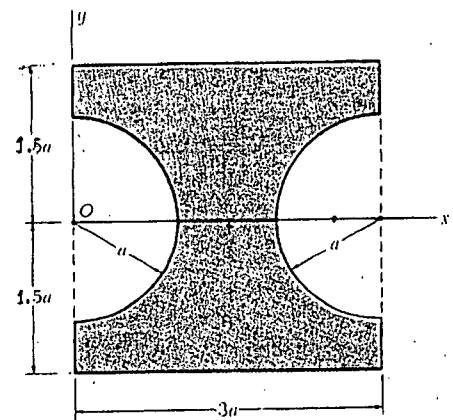

Fig. 8(b)

The figures in the margin indicate full marks.

Symbols have their usual meaning.

USE SEPARATE SCRIPTS FOR EACH SECTION

SECTION – A

There are **FOUR** questions in this Section. Answer any **THREE** questions.

1. (a) Find values of the constants  $k$  and  $m$ , if possible, that will make the function (20)

$$f(x) = \begin{cases} x^2 + 5 & x > 2 \\ m(x+1) + k & -1 < x \leq 2 \\ 2x^3 + x + 7 & x \leq -1 \end{cases} \quad \text{continuous everywhere.}$$

- (b) Evaluate (i)  $\lim_{x \rightarrow 0} \left[ \frac{1}{x^2} - \frac{1}{\sin^2 x} \right]$  (ii)  $\lim_{x \rightarrow +\infty} (\ln x)^{1/x}$  (15)

2. (a) If  $x = \sin\left(\frac{\ln y}{m}\right)$ , then show that  $(1-x^2)y_{n+2} - (2n+1)xy_{n+1} - (m^2+n^2)y_n = 0$ . Also find the value of  $y_n$ , when  $x = 0$ . (17)

- (b) If  $u = \ln(x^3 + y^3 + z^3 - 3xyz)$  then (i) show that  $\frac{\partial u}{\partial x} + \frac{\partial u}{\partial y} + \frac{\partial u}{\partial z} = \frac{3}{x+y+z}$  and

- (ii) Find the value of  $\left(\frac{\partial}{\partial x} + \frac{\partial}{\partial y} + \frac{\partial}{\partial z}\right)^3 u$ . (18)

3. (a) Given  $f(x) = \sin x - \cos x$ ,  $[-\pi, \pi]$ . Analyze the trigonometric function  $f$  over the specified interval, stating where  $f$  is increasing, decreasing, concave up and concave down, and stating the  $x$ -coordinates of all critical points and inflection points. Draw the graph of  $f$  by using the above information. (22)

- (b) Find an interval  $[a, b]$  on which the function  $f(x) = x^4 + x^3 - x^2 + x - 2$  satisfies the hypotheses of Rolle's Theorem and find all values of  $c$  in the interval that satisfy the conclusion of the theorem. (13)

4. (a) Expand the function  $\sin x$  in powers of  $\left(x - \frac{\pi}{2}\right)$  with remainder  $R_n$  in Lagrange's and Cauchy's form. (17)

- (b) Find the polar tangent, normal, subtangent and subnormal for the curve  $r = a(1 - \cos \theta)$ . (18)

**MATH 121****SECTION – B**

There are **FOUR** questions in this Section. Answer any **THREE** questions.

5. (a) Transform the equation  $17x^2 + 18xy - 7y^2 - 16x - 32y - 18 = 0$  to one in which there is no term involving  $x$ ,  $y$  and  $xy$ . (18)
- (b) Find the values of  $k$  so that the equation  $3x^2 + 10xy + 8y^2 - kx - 26y - 21 = 0$  represents a pair of straight lines. Also find their point of intersection and the angle between the lines. (17)
6. (a) Prove that the straight line joining the origin to the points of intersection of the straight line  $kx + hy = 2hk$  with the curve  $(x-h)^2 + (y-k)^2 = c^2$  are at right angles if  $h^2 + k^2 = c^2$ . (18)
- (b) Prove that the necessary and sufficient condition that two of the lines represented by the equation  $ay^4 + bxy^3 + cx^2y^2 + dx^3y + ex^4 = 0$  should be at right angles is  $(b+d)(ad+bc) + (e-a)^2(a+c+e) = 0$ . (17)
7. (a) Tangents are drawn from the point  $(h, k)$  to the circle  $x^2 + y^2 = a^2$ , prove that the area of the triangle formed by them and their chord of contact is  $\frac{a(h^2 + k^2 - a^2)^{3/2}}{h^2 + k^2}$ . (18)
- (b) Find the co-ordinates of limiting points of the coaxial system to which circles  $x^2 + y^2 + 4x + 2y + 5 = 0$  and  $x^2 + y^2 + 2x + 4y + 7 = 0$  belong. (17)
8. (a) Obtain the equation of the asymptotes of the hyperbola  $2xy + 3x^2 + 4x - 9 = 0$ . Also find the equation of conjugate hyperbola. (18)
- (b) Find the locus of the middle point of chords of the parabola  $y^2 = 4ax$  which subtends a right angle at the vertex. (17)
-

BANGLADESH UNIVERSITY OF ENGINEERING AND TECHNOLOGY, DHAKA

L-1/T-1 B. Sc. Engineering Examinations 2015-2016

Sub : **PHY 111** (Physical optics, Waves and Oscillation, Heat and Thermodynamics)

Full Marks : 210

Time : 3 Hours

The figures in the margin indicate full marks.

USE SEPARATE SCRIPTS FOR EACH SECTION

**SECTION – A**There are **FOUR** questions in this Section. Answer any **THREE** questions.

1. (a) Describe the working principles of platinum resistance thermometer and thermo-electric thermometer. Draw both the thermometers mentioning each part. (19)
- (b) Explain the relative merits of thermoelectric and platinum resistance methods of measuring temperature. (8)
- (c) The resistance  $R_t$  of a platinum wire at temperature  $t^\circ\text{C}$ , measured on the gas scale, is given by  $R_t = R_0 (1 + at + bt^2)$  where  $a = 3.8 \times 10^{-3}$  and  $b = -5.6 \times 10^{-7}$ . What temperature will the platinum thermometer indicate when the temperature on the gas scale is  $200^\circ\text{C}$ ? (8)
2. (a) State second law of thermodynamics in terms of entropy. Draw the P-V and T-S diagrams for a Carnot cycle. (10)
- (b) Obtain expression for the change in entropy of a gas when it is heated (i) at constant volume, (ii) at constant pressure and (iii) in a general manner. (17)
- (c) Find the difference in entropy between 10 gm of water at  $100^\circ\text{C}$  and 10 gm of steam at  $100^\circ\text{C}$ . (8)
3. (a) Why maxwell's thermodynamic relations are important? Show that (17)

$$(i) \left(\frac{\partial Q}{\partial V}\right)_T = T \left(\frac{\partial P}{\partial T}\right)_V \quad (ii) \left(\frac{\partial T}{\partial P}\right)_S = T \left(\frac{\partial V}{\partial Q}\right)_P$$

The symbols have their usual meanings.
- (b) Derive Clausius Clapeyron's latent heat equation using Maxwell's thermodynamic relation. (10)
- (c) The specific volume of steam at  $100^\circ\text{C}$  and 76 cm of mercury pressure is 1671 cc per gm, and the latent heat of vaporisation of water = 540 cal/gm. Find the change in boiling point of water due to change in pressure of 1 cm of mercury. (8)
4. (a) Derive an expression for the intensity at a point on a screen due to a Fraunhofer type of diffraction at a single slit and obtain the condition for the secondary maxima. (25)
- (b) A light of 500 nm wavelength is incident normally on a single slit. The first minimum of the Fraunhofer diffraction is observed to lie at a distance of  $5 \times 10^{-3}$  m from the central maximum on a screen placed at a distance of 2 m away from the slit. What is the width of the slit? (10)

**PHY 111****SECTION – B**

There are **FOUR** questions in this Section. Answer any **THREE** questions.

5. (a) What do you mean by Interference of light ? Show with a neat diagram how coherent sources are produced in Newton's rings experiment. (2+5)
- (b) Derive an expression for the diameter of the n-th dark ring in the case of Newton's rings arrangement for reflected light. (18)
- (c) Light of wavelength  $6000\text{\AA}$  falls normally on a thin wedge shaped film of refractive index 1.4, forming fringes that are 2 mm apart. Find the angle of the wedge. (10)
6. (a) Distinguish between positive and negative crystals. Show with a neat diagram how Nicol prism acts as a polarizer. (5+5)
- (b) What do you mean by double refraction? Explain the phenomena of double refraction in uniaxial crystal. (15)
- (c) Calculate the thickness of a calcite plate which would convert plane polarized light into circularly polarized light. The refractive indices for o-ray and e-ray are 1.658 and 1.486, respectively at wavelength of  $5890\text{\AA}$ . (10)
7. (a) Define the characteristics of simple harmonic motion. Establish the differential equation of simple harmonic motion. (8)
- (b) Calculate the total energy of a body executing simple harmonic motion. Show that the principle of conservation of energy is obeyed by a harmonic oscillator. (18)
- (c) A particle performs simple harmonic motion given by the equation  $y = 20 \sin (wt + \alpha)$ . If the time period is 30 sec and the particle has a displacement of 10 cm at  $t = 0$ , find (i) epoch; (ii) the phase angle at  $t = 5$  sec, and (iii) the phase difference between two positions of the particle 15 sec apart. (9)
8. (a) What are reverberation and reverberation time? (6)
- (b) By using the Sabine's assumptions show that the intensity of sound in an auditorium increases exponentially with time. Deduce an expression for reverberation time. (22)
- (c) Calculate the reverberation time of a  $2400\text{ m}^3$  hall room from the following data: (7)

Surface	Area ( $\text{m}^2$ )	Coefficient of absorption
Plaster ceiling	500	0.02
Plaster walls	600	0.03
Wood floor	500	0.06
Wood doors	20	0.06

-----