

BANGLADESH UNIVERSITY OF ENGINEERING AND TECHNOLOGY, DHAKA

L-1/T-1 B. Sc. Engineering Examinations 2015-2016

Sub : **PHY 103** (Waves and Oscillation, Optics)

Full Marks : 210

Time : 3 Hours

The figures in the margin indicate full marks.

USE SEPARATE SCRIPTS FOR EACH SECTION

**SECTION – A**There are **FOUR** questions in this Section. Answer any **THREE** questions.

1. (a) Can two independent light sources (eg. Candles) produce observable interference pattern on a screen? (5)
- (b) Explain the formation of coherent sources in the case of Fresnel's biprism. How can the separation between such coherent sources be measured in the experiment with a biprism? (20)
- (c) If a parallel beam of light of wavelength 589.3 nm is incident at an angle of  $45^\circ$  on a glass plate of refractive index 1.5, calculate the smallest thickness of the glass plate for a fringe of minimum intensity. (10)
2. (a) Distinguish between interference and diffraction of light. (7)
- (b) Define resolving power of an optical instrument. Discuss the Fraunhofer diffraction of light at a circular aperture. (3+15)
- (c) In a Fraunhofer diffraction pattern due to a circular aperture, the screen is at a distance of 1.5 m from a convex lens. The aperture is illuminated by sodium light of wavelength 589.3 nm. The diameter of the aperture is  $0.2 \times 10^{-3}$  m. Calculate the separation between the central disc and the first minimum. (10)
3. (a) What do you mean by positive and negative uniaxial crystals? (10)
- (b) Explain the phenomenon of double refraction in a uniaxial crystal. (15)
- (c) Two polarizing sheets have polarizing directions parallel so that the intensity of the transmitted light is maximum. Through what angle must either sheet be turned if the intensity is to drop by half? (10)
4. (a) What do you mean by simple harmonic motion? Briefly discuss the impact of oscillation in our daily life. (7)
- (b) While studying spring-mass system we consider the spring to an ideal spring having point-mass. But in reality the spring has a finite mass and it affects the motion of the spring-mass system. With a detailed mathematical analysis show that the time period of oscillation for spring-mass system is  $2\pi\sqrt{\frac{M + M_s}{K}}$  if the springs have a finite mass  $M_s$ . (20)

**PHY 103**

**Contd ... Q. No. 4**

(c) A load  $M$  is attached to two spring having spring constant  $k_1$ , and  $k_2$  respectively as shown in the following figures.

(8)

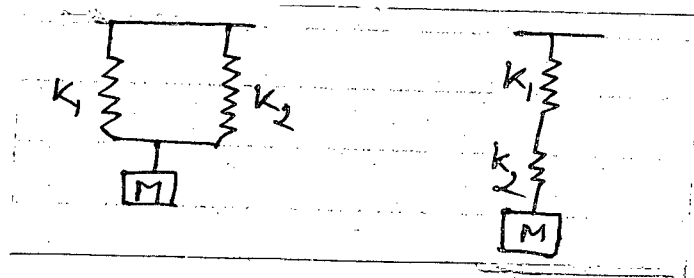

If the spring is considered massless, what would be the period of oscillation?

**SECTION – B**

There are **FOUR** questions in this Section. Answer any **THREE** questions.

5. (a) What do you mean by damped harmonic motion. Write down a general expression for the displacement of damped oscillation and from this show how the energy of a damped oscillator decays with time.

(12)

(b) Define 'Q-factor' for an oscillator and briefly explain the physical significance of  $Q$  of an oscillator.

(8)

(c) According to the classical electromagnetic theory an accelerated electron radiates energy at the rate  $ke^2a^2/c^3$ , where  $k = 6 \times 10^9 \text{ N-m/c}^2$ ,  $e =$  electronic charge (c),  $a =$  instantaneous acceleration ( $\text{m/sec}^2$ ), and  $c =$  speed of light ( $\text{m/sec}$ ).

(15)

(i) If an electron oscillating along a straight line with frequency  $\nu$ (Hz) and amplitude  $A$ , how much energy would it radiate away during 1 cycle. (Assume that the motion is describe by  $x = A \sin 2\pi\nu t$ )

(ii) What is the Q function of the oscillation?

6. (a) Consider that a one-dimensional oscillator of mass  $m$  is subjected to periodic force and a resistive force is present during oscillation. Set up an expression for the differential equation of motion of the system.

(8)

(b) Using the differential equation you write in (Question 6a) derive an expression for the displacement of the oscillator for steady state condition.

(17)

(c) Consider a damped oscillator of mass  $m = 0.2 \text{ kg}$ ,  $b = 4 \text{ N-m}^{-1} \text{ sec}$  and  $k = 80 \text{ N-m}^{-1}$ . Suppose that the oscillator is driven by a force  $F = F_0 \cos \omega t$  with  $F_0 = 2 \text{ N}$  and  $\omega = 30 \text{ sec}^{-1}$ .

(10)

**PHY 103**

**Contd ... Q. No. 6(c)**

- (i) What are the value of the amplitude and phase for steady state response?  
(ii) How much energy is dissipated against the resistive force in one cycle?
7. (a) What do you mean by cardinal points of a thick lens? Indicate each cardinal point with suitable diagram. (10)
- (b) Show that the equivalent power of two coaxial thin lenses separated by a certain distance (d) can be expressed by the equation:  $P = P_1 + P_2 - dP_1P_2$ , where the symbols have their usual meanings. (17)
- (c) Two coaxial thin convex lenses of focal length 20 cm and 10 cm are 3 cm apart. Calculate (i) the value of equivalent focal length of the combination and (ii) find the distance ( $\alpha, \beta$ ) of the principal points from the individual lenses. (8)
8. (a) What do you mean by distortion in lens? Briefly describe the ways of minimization of spherical aberration. (10)
- (b) Show that a single lens can not produce an image free from chromatic aberration. (17)
- (c) Two lenses have dispersive powers in the ratio of 2:3. The lenses are used in the manufacture of an achromatic object of focal length 20 cm. What are the focal lengths of the lenses? (8)
-

BANGLADESH UNIVERSITY OF ENGINEERING AND TECHNOLOGY, DHAKA

L-1/T-1 B. Sc. Engineering Examinations 2015-2016

Sub : **MATH 171** (Calculus and Differential Equations)

Full Marks : 210

Time : 3 Hours

The figures in the margin indicate full marks.

Symbols have their usual meaning.

USE SEPARATE SCRIPTS FOR EACH SECTION

**SECTION – A**There are **FOUR** questions in this Section. Answer any **THREE**.

1. (a) A function  $f(x)$  is defined as follows:  $f(x) = \begin{cases} -x & \text{when } x \leq 0 \\ x & \text{when } 0 < x < 1 \\ 1-x & \text{when } x \geq 1 \end{cases}$

Discuss the continuity and differentiability at  $x = 0$  and  $x = 1$ . Also sketch the graph of the function. (17)

(b) Evaluate (i)  $\lim_{x \rightarrow 1} \frac{x^2 - x \log x + \log x - 1}{x - 1}$  (ii)  $\lim_{x \rightarrow 0} \frac{x \tan 2x - 2x \tan x}{(1 - \cos 2x)^2}$ . (18)

2. (a) Find  $(y_n)_0$ , where  $y = \cos(2 \cos^{-1} x)$ . (13)

(b) State Euler's theorem and verify this theorem for the function

$$u = \sin^{-1}\left(\frac{x}{y}\right) + \tan^{-1}\left(\frac{y}{x}\right). \quad (11)$$

(c) Find the equation of the tangent and normal to the curve  $y(x-2)(x-3) - x + 7 = 0$  at the point where it cuts the axis of  $x$ . (11)

3. (a) Find the maximum and minimum values of  $u$  where  $u = \frac{4}{x} + \frac{36}{y}$  and  $x + y = 2$ . (13)

(b) A wire of length 20 metre is bent so as to form a circular sector of maximum area.

Find the radius of the circular sector. (11)

(c) Find the angle of intersection of the curves  $r^n = a^n \cos n\theta$  and  $r^n = b^n \sin n\theta$ . (11)

4. Find the following:

(a)  $\int \frac{x^3}{(a+bx)^4} dx$  (12)

(b)  $\int \frac{x^2+1}{x^4+1} dx$  (13)

(c)  $\int e^x \frac{2 - \sin 2x}{1 - \cos 2x} dx$  (10)

**MATH 171****SECTION – B**

There are **FOUR** questions in this Section. Answer any **THREE**.

5. (a) Evaluate  $\int_{\pi/2}^{\pi/6} \sec^2 2x dx$  by the process of summation. (15)

(b) Evaluate the following  $\int_0^1 \frac{dx}{(1-x^2)\sqrt{1-x^2}}$ . (10)

(c) Prove that  $\int_0^1 \frac{\sin^2 x}{1 + \sin x \cos x} dx = \frac{\pi}{3\sqrt{3}}$ . (10)

6. (a) Find the area between the curve  $r = a(\sec\theta + \cos\theta)$  and its asymptote. (15)

(b) Find the volume and the surface area of the sphere formed by the revolution of the circle  $x^2 + y^2 = r^2$  about its diameter. (20)

7. (a) Determine whether or not the following differential equation is exact. If possible, solve it.  $(\theta^2 + 1)\cos r dr - 2\theta \sin r d\theta = 0$ . (15)

(b) The population  $x$  of a certain city satisfies the logistic law  $\frac{dx}{dt} = \frac{1}{100}x - \frac{1}{(10)^8}x^2 \dots (*)$ . (20)

where time  $t$  is measured in years. Given that the population of this city is 100,000 in 1980, determine the population as a function of time for  $t > 1980$ . In particular, answer the following questions:

(i) What will be the population in 2020?

(ii) In what year does the 1980 population double?

(iii) Assuming the given differential equation (\*) applies for all  $t > 1980$ , how large will the population ultimately be?

8. Solve the following:

(a)  $\left(x \tan \frac{y}{x} + y\right) dx - x dy = 0$ . (10)

(b)  $\frac{d^3 y}{dx^3} - 5 \frac{d^2 y}{dx^2} + 7 \frac{dy}{dx} - 3y = 0$ . (10)

(c)  $\frac{d^2 y}{dx^2} + 2 \frac{dy}{dx} + 10y = 5xe^{-2x}$ . (15)

-----

BANGLADESH UNIVERSITY OF ENGINEERING AND TECHNOLOGY, DHAKA

L-1/T-1 B. Sc. Engineering Examinations 2015-2016

Sub : **CHEM 107** (Inorganic and Physical Chemistry)

Full Marks : 210

Time : 3 Hours

The figures in the margin indicate full marks.

USE SEPARATE SCRIPTS FOR EACH SECTION

**SECTION – A**There are **FOUR** questions in this Section. Answer any **THREE** questions.

- What are photons? What role did Einstein's explanation of the photoelectric effect play in the development of the particle – wave interpretation of the nature of electromagnetic radiation? (9)
  - What do you mean by Eigen values and Eigen functions? (6)
  - An electron in the hydrogen atom makes a transition from an energy state of principal quantum numbers  $n_i$  to the  $n = 2$  state. If the photon emitted has a wavelength of 434 nm, what is the value of  $n_i$ ? (8)
  - State and discuss Heisenberg uncertainty principle? How this principle goes against Bohr's theory? (6)
  - Give the values of four quantum numbers of an electron in the following orbitals (i) 3s, (ii) 4p, (iii) 3d. (6)
- Explain Why, for isoelectronic ions, the anions are larger than the cations. List the following ions in order of increasing ionic radius:  $N^{3-}$ ,  $Na^+$ ,  $F^-$ ,  $Mg^{2+}$ ,  $O^{2-}$ . (4+5=9)
  - Ionization energy is usually measured in the gaseous state. Why? (7)
  - What are the limitations of Valence Bond Theory of complexes? (5)
  - Write balanced equations for the reactions of Cr and Cu metals with HCl(aq). (4)
  - When water ligands in  $[Ti(H_2O)_6]^{3+}$  are replaced by  $CN^-$  ligands to give  $[Ti(CN)_6]^{3-}$  the maximum absorption shifts from 500 nm to 450 nm. Is this shift in the expected direction? Explain. What color do you expect to observe for this ion? (10)
- Discuss the basic features of the VSEPR model. Predict the geometry of the following molecules or ions, using the VSEPR method: (i)  $BeCl_2$ , (ii)  $NO_2^-$ , (iii)  $SiCl_4$ . (7+6=13)
  - Explain the significance of Bond Order. Can bond order be used for quantitative comparisons of the strengths of chemical bonds? Explain why the bond order of  $N_2$  is greater than that of  $N_2^+$  but the bond order of  $O_2$  is less than that of  $O_2^+$ . (4+4+4=12)
  - Give the IUPAC name for each of the following: (i)  $[Fe(CO)_5]$  (ii)  $[Rh(CN)_2(en)_2]^+$  (en = ethylene diamine) (iii)  $[Cr(NH_3)_4 SO_4]Cl$  (iv)  $[MnO_4]^-$ . (4)

## CHEM 107

### Contd ... Q. No. 3

- (d) Do any of the following stable octahedral complexes have geometric isomers? If so, draw then (i)  $[\text{Co}(\text{NH}_3)_5\text{Cl}]^{2+}$  (ii)  $\text{Co}(\text{NH}_3)_4(\text{H}_2\text{O})_2^{3+}$ . (6)
4. (a) Define hexagonal close-packed structure and cubic close-packed structure. (8)
- (b) Tungsten has a body-centered cubic lattice with all atoms at the lattice points. The edge length of the unit cell is 316.5 pm. The atomic mass of tungsten is 183.8 amu. Calculate its density. (8)
- (c) What do you mean by Buffer solution? Which of the following solution can act as a buffer? (i) KCN/HCN, (ii)  $\text{Na}_2\text{SO}_4/\text{NaHSO}_4$ , (iii)  $\text{NH}_3/\text{NH}_4\text{NO}_3$  (iv) NaI/HI. (3+4=7)
- (d) Define coordination number. What is the coordination number of  $\text{Cs}^+$  in CsCl? of  $\text{Na}^+$  in NaCl? of  $\text{Zn}^{2+}$  in ZnS? (3+9=12)

### SECTION – B

There are **FOUR** questions in this Section. Answer any **THREE** questions.

5. (a) Describe the factors that affect the solubility of an ionic solid in liquid. The hypothetical ionic compound  $\text{XB}_2$  is very soluble in water. The lattice energies for these compounds are about the same. Provide an explanation for the solubility difference between these compounds. (10)
- (b) Define Raoult's law. Define each term in the equation representing Raoult's law, and give its units. What is an ideal solution? (10)
- (c) Each of the following substances is dissolved in a separate 10.0 L container of water: 1.5 mol NaCl, 1.3 mol  $\text{Na}_2\text{SO}_4$ , 2.0 mol  $\text{MgCl}_2$  and 2.0 mol KBr. Without doing extensive calculations, rank the osmotic pressure of the solutions from highest to lowest. Justify your answer. (7)
- (d) A solution of 2.50 g of a compound of empirical formula  $\text{C}_6\text{H}_5\text{P}$  in 25.0 g of benzene is observed to freeze at  $4.3^\circ\text{C}$ . Calculate the molar mass of the solute and its molecular formula [Use the attached data sheet]. (8)
6. (a) Briefly explain the Clausius-Clapeyron equation plotting the logarithm of vapor pressure versus  $1/T$ . Carbon disulfide,  $\text{CS}_2$ , has a normal boiling point of  $46^\circ\text{C}$  and a heat of vaporization of 26.8 kJ/mol. What is the vapor pressure of  $\text{CS}_2$  at  $35^\circ\text{C}$ ? (6+7=13)
- (b) Use graph paper and sketch the phase diagram of Argon (Ar) from the following information: normal melting point,  $-189^\circ\text{C}$ ; normal boiling point,  $-186^\circ\text{C}$ ; triple point,  $-191^\circ\text{C}$ , 0.68 atm; critical point,  $-122^\circ\text{C}$ , 48 atm. Label each phase region on the diagram. (8)

**CHEM 107****Contd ... Q. No. 6**

(c) Describe how you could liquefy the following gases: (i) Methyl chloride,  $\text{CH}_3\text{Cl}$  (critical point,  $144^\circ\text{C}$ , 66 atm) (ii) Oxygen,  $\text{O}_2$  (critical point,  $-119^\circ\text{C}$ , 50 atm) (6)

(d) Given the following hypothetical thermochemical equations:

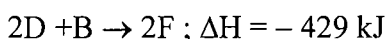
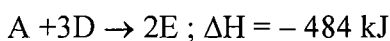
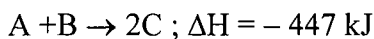

Calculate  $\Delta\text{H}$  for the equation:  $4\text{E} + 5\text{B} \rightarrow 4\text{C} + 6\text{F}$ . (8)

7. (a) Briefly discuss the factors that affect the rates of chemical reactions. Which of the factors affect the magnitude of the rate constant? Which factor(s) do not affect the magnitude of the rate constant? Why? (10)

(b) The decomposition of  $\text{H}_2\text{O}_2$  is a first order reaction: (4+7+7=18)

$\text{H}_2\text{O}_2(\text{aq}) \rightarrow \text{H}_2\text{O}(\text{l}) + \frac{1}{2}\text{O}_2(\text{g})$ . The half life of the reaction is 17.0 minutes.

(i) What is the rate constant of the reaction?

(ii) If you had a bottle of  $\text{H}_2\text{O}_2$ , how long would it take for 86.0% to decompose?

(iii) If you started the reaction with  $[\text{H}_2\text{O}_2] = 0.100 \text{ M}$ . What would be the  $\text{H}_2\text{O}_2$  concentration after 15.0 minutes?

(c) Draw a potential energy diagram for an uncatalyzed exothermic reaction. On the same diagram, indicate the change that results on the additions of a catalyst. (7)

8. (a) What is reaction quotient? What are the uses of it? The following reaction has an equilibrium constant  $K_c$  equal to  $3.07 \times 10^{-4}$  at  $24^\circ\text{C}$ . (5+7=12)

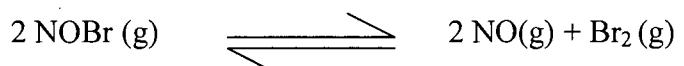

For each of the following compositions, decide whether the reaction mixture is at equilibrium. If it is not, decide which direction the reaction should go.

(i)  $[\text{NOBr}] = 0.0720 \text{ M}$ ,  $[\text{NO}] = 0.0162 \text{ M}$ ,  $[\text{Br}_2] = 0.0123 \text{ M}$

(ii)  $[\text{NOBr}] = 0.121 \text{ M}$ ,  $[\text{NO}] = 0.0159 \text{ M}$ ,  $[\text{Br}_2] = 0.0139 \text{ M}$

A standard electrochemical cell is made by dipping an iron electrode into a  $1.0 \text{ M Fe}^{2+}$  solution and a copper electrode into a  $1.0 \text{ M Cu}^{2+}$  solution. Use the attached data sheet.

(i) What is the spontaneous chemical reaction, and what is the maximum potential produced by this cell?

(ii) What would be the effect on the potential of this cell if sodium carbonate were added to the  $\text{Cu}^{2+}$  half-cell and  $\text{Cu}^{2+}$  is precipitated as  $\text{CuCO}_3$ ? (8)

(c) Construct a pH meter using the following cell:



What is the pH of the solution when the cell potential is  $0.475 \text{ V}$  at  $25^\circ\text{C}$ ? (8)

(d) Explain the electrochemical process of the rusting of iron. How does iron itself can act as anode as well as cathode during this process? (7)



Appendixes - Chem 107

Appendix A. Boiling-Point-Elevation Constants ( $K_b$ ) and Freezing-Point-Depression Constants ( $K_f$ )

Solvent	Boiling Point (°C)	Freezing Point (°C)	$K_b$ (°C/m)	$K_f$ (°C/m)
Acetic Acid (CH <sub>3</sub> COOH)	118.5	16.60	3.08	3.59
Benzene (C <sub>6</sub> H <sub>6</sub> )	80.2	5.455	2.61	5.065
Camphor (C <sub>10</sub> H <sub>16</sub> O)	---	179.5	---	40
Carbon disulfide (CS <sub>2</sub> )	46.3	---	2.40	---
Cyclohexane (C <sub>6</sub> H <sub>12</sub> )	80.74	6.55	2.79	20.0
Ethanol (C <sub>2</sub> H <sub>5</sub> OH)	78.3	---	1.07	---
Water (H <sub>2</sub> O)	100.000	0.000	0.512	1.858

Appendix B. Standard Reduction Potentials in Aqueous Solution at 25 °C

Cathode (Reduction) Half-Reaction	Standard Potential, $E^\circ$ (V)
$\text{Li}^+(aq) + e^- \rightleftharpoons \text{Li}(s)$	-3.04
$\text{K}^+(aq) + e^- \rightleftharpoons \text{K}(s)$	-2.92
$\text{Ca}^{2+}(aq) + 2e^- \rightleftharpoons \text{Ca}(s)$	-2.76
$\text{Na}^+(aq) + e^- \rightleftharpoons \text{Na}(s)$	-2.71
$\text{Mg}^{2+}(aq) + 2e^- \rightleftharpoons \text{Mg}(s)$	-2.38
$\text{Al}^{3+}(aq) + 3e^- \rightleftharpoons \text{Al}(s)$	-1.66
$2\text{H}_2\text{O}(l) + 2e^- \rightleftharpoons \text{H}_2(g) + 2\text{OH}^-(aq)$	-0.83
$\text{Zn}^{2+}(aq) + 2e^- \rightleftharpoons \text{Zn}(s)$	-0.76
$\text{Cr}^{3+}(aq) + 3e^- \rightleftharpoons \text{Cr}(s)$	-0.74
$\text{Fe}^{2+}(aq) + 2e^- \rightleftharpoons \text{Fe}(s)$	-0.41
$\text{Cd}^{2+}(aq) + 2e^- \rightleftharpoons \text{Cd}(s)$	-0.40
$\text{Ni}^{2+}(aq) + 2e^- \rightleftharpoons \text{Ni}(s)$	-0.23
$\text{Sn}^{2+}(aq) + 2e^- \rightleftharpoons \text{Sn}(s)$	-0.14
$\text{Pb}^{2+}(aq) + 2e^- \rightleftharpoons \text{Pb}(s)$	-0.13
$\text{Fe}^{3+}(aq) + 3e^- \rightleftharpoons \text{Fe}(s)$	-0.04
$2\text{H}^+(aq) + 2e^- \rightleftharpoons \text{H}_2(g)$	0.00
$\text{Sn}^{4+}(aq) + 2e^- \rightleftharpoons \text{Sn}^{2+}(aq)$	0.15
$\text{Cu}^{2+}(aq) + e^- \rightleftharpoons \text{Cu}^+(aq)$	0.16
$\text{ClO}_4^-(aq) + \text{H}_2\text{O}(l) + 2e^- \rightleftharpoons \text{ClO}_3^-(aq) + 2\text{OH}^-(aq)$	0.17
$\text{AgCl}(s) + e^- \rightleftharpoons \text{Ag}(s) + \text{Cl}^-(aq)$	0.22
$\text{Cu}^{2+}(aq) + 2e^- \rightleftharpoons \text{Cu}(s)$	0.34
$\text{ClO}_3^-(aq) + \text{H}_2\text{O}(l) + 2e^- \rightleftharpoons \text{ClO}_2^-(aq) + 2\text{OH}^-(aq)$	0.35
$\text{IO}^-(aq) + \text{H}_2\text{O}(l) + 2e^- \rightleftharpoons \text{I}^-(aq) + 2\text{OH}^-(aq)$	0.49
$\text{Cu}^+(aq) + e^- \rightleftharpoons \text{Cu}(s)$	0.52
$\text{I}_2(s) + 2e^- \rightleftharpoons 2\text{I}^-(aq)$	0.54
$\text{ClO}_2^-(aq) + \text{H}_2\text{O}(l) + 2e^- \rightleftharpoons \text{ClO}^-(aq) + 2\text{OH}^-(aq)$	0.59
$\text{Fe}^{3+}(aq) + e^- \rightleftharpoons \text{Fe}^{2+}(aq)$	0.77
$\text{Hg}_2^{2+}(aq) + 2e^- \rightleftharpoons 2\text{Hg}(l)$	0.80
$\text{Ag}^+(aq) + e^- \rightleftharpoons \text{Ag}(s)$	0.80
$\text{Hg}^{2+}(aq) + 2e^- \rightleftharpoons \text{Hg}(l)$	0.85
$\text{ClO}^-(aq) + \text{H}_2\text{O}(l) + 2e^- \rightleftharpoons \text{Cl}^-(aq) + 2\text{OH}^-(aq)$	0.90
$2\text{Hg}_2^{2+}(aq) + 2e^- \rightleftharpoons \text{Hg}_2^{2+}(aq)$	0.90
$\text{NO}_3^-(aq) + 4\text{H}^+(aq) + 3e^- \rightleftharpoons \text{NO}(g) + 2\text{H}_2\text{O}(l)$	0.96
$\text{Br}_2(l) + 2e^- \rightleftharpoons 2\text{Br}^-(aq)$	1.07
$\text{O}_2(g) + 4\text{H}^+(aq) + 4e^- \rightleftharpoons 2\text{H}_2\text{O}(l)$	1.23
$\text{Cr}_2\text{O}_7^{2-}(aq) + 14\text{H}^+(aq) + 6e^- \rightleftharpoons 2\text{Cr}^{3+}(aq) + 7\text{H}_2\text{O}(l)$	1.33
$\text{Cl}_2(g) + 2e^- \rightleftharpoons 2\text{Cl}^-(aq)$	1.36
$\text{Ce}^{4+}(aq) + e^- \rightleftharpoons \text{Ce}^{3+}(aq)$	1.44
$\text{MnO}_4^-(aq) + 8\text{H}^+(aq) + 5e^- \rightleftharpoons \text{Mn}^{2+}(aq) + 4\text{H}_2\text{O}(l)$	1.49
$\text{H}_2\text{O}_2(aq) + 2\text{H}^+(aq) + 2e^- \rightleftharpoons 2\text{H}_2\text{O}(l)$	1.78
$\text{Co}^{3+}(aq) + e^- \rightleftharpoons \text{Co}^{2+}(aq)$	1.82
$\text{S}_2\text{O}_8^{2-}(aq) + 2e^- \rightleftharpoons 2\text{SO}_4^{2-}(aq)$	2.01
$\text{O}_3(g) + 2\text{H}^+(aq) + 2e^- \rightleftharpoons \text{O}_2(g) + \text{H}_2\text{O}(l)$	2.07
$\text{F}_2(g) + 2e^- \rightleftharpoons 2\text{F}^-(aq)$	2.87



The figures in the margin indicate full marks.

Symbols have their usual meaning.

USE SEPARATE SCRIPTS FOR EACH SECTION

**SECTION – A**

There are **FOUR** questions in this Section. Answer any **THREE** questions.

1. (a) A resistance of  $10 \Omega$  is in series with a  $303 \mu\text{F}$  capacitor. If the voltage drop across the capacitor is  $150 \sin(220 t - 60^\circ)$  volts, find the expression of the voltage drop across the entire series circuit. Also find the expression of the current flowing through the circuit. (17)

- (b) A 110-V rms, 60 Hz source is applied to a load impedance  $Z$ . The apparent power entering the load is 120 VA at a power factor of 0.707 lagging. (18)

- (i) Calculate the complex power.
- (ii) Find the current supplied to the load.
- (iii) Determine  $Z$ .
- (iv) Assuming  $Z = R + j\omega L$ , find the values of  $R$  and  $L$ .

2. (a) Determine  $i_0$  in the circuit of Fig. for Q. No. 2(a). (25)

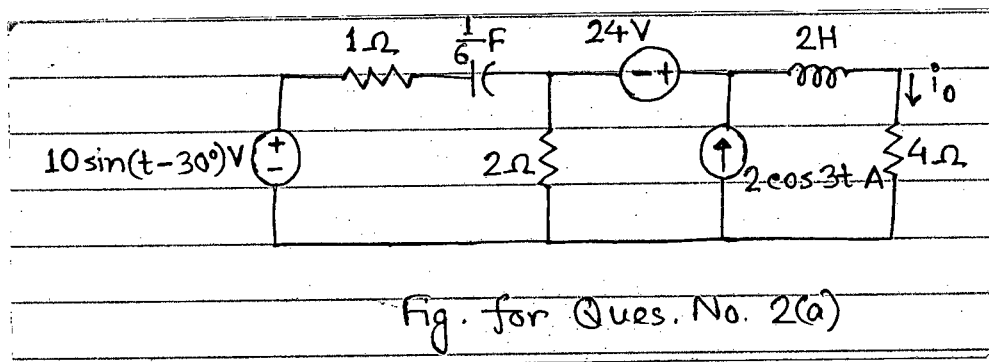

- (b) Find the value of parallel capacitor needed to correct a load of 140 kVAR at 0.85 lagging p.f. to unity p.f. Assume the load is supplied by a 110 V (rms). 60 Hz line. (10)

3. (a) Which of the two periodic current waveforms,  $i_1(t)$  and  $i_2(t)$ , in the Fig. for Q. No. 3(a) will deliver more average power to a resistor? (15)

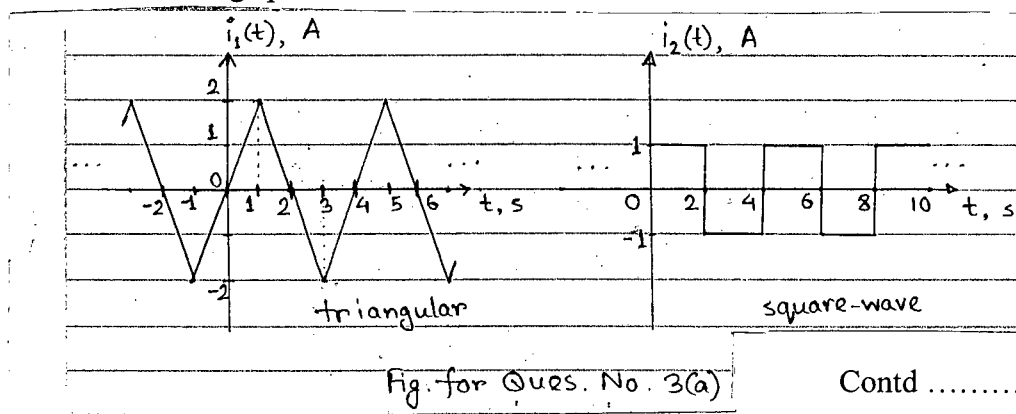

**EEE 155**

**Contd ... Q. No. 3**

(b) For the circuit in Fig. for Q. No. 3(b), find the value of  $R_L$ , for which the reading of the wattmeter will be maximum. (20)

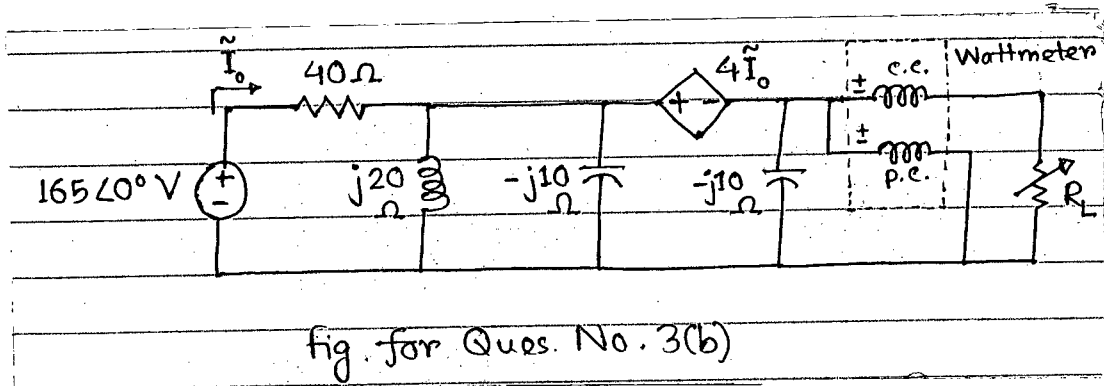

4. (a) For the circuit in Fig. for Q. No. 4(a), find the wattmeter reading. (12)

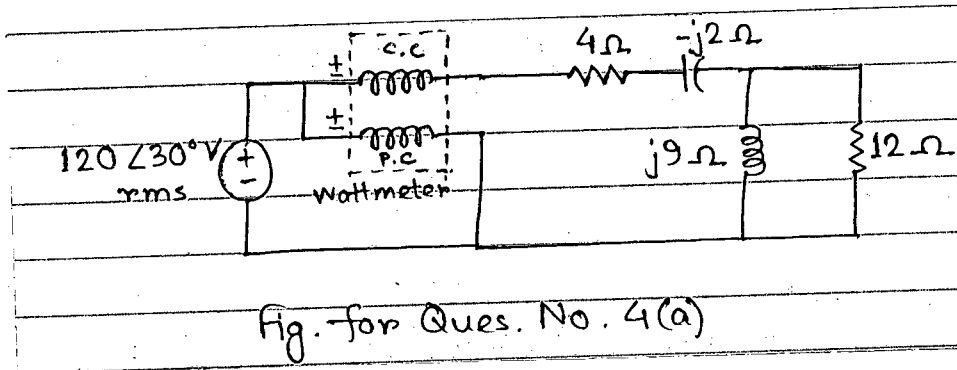

(b) (i) For the series-parallel magnetic circuit of Fig. for Q. No. 4(b) (see page-5), find the value of  $I$  required to establish a flux of  $\Phi_g = 2 \times 10^{-4}$  Wb in the air gap. (18)

(ii) Refer to the question in the part (i). "To increase the air gap flux twofold, the value of  $I$  has to be doubled." – Do you agree? Why or why not? (5)

**SECTION – B**

There are **FOUR** questions in this Section. Answer any **THREE** questions.

Please box your answers.

5. (a) Find the equivalent resistance  $R_{ab}$  in the circuit of Fig. for Q. No. 5(a). If a voltage source of 50 V is connected between a and b, what will be the voltage across the resistance  $R_1 = 2 \text{ k}\Omega$ ? (20)

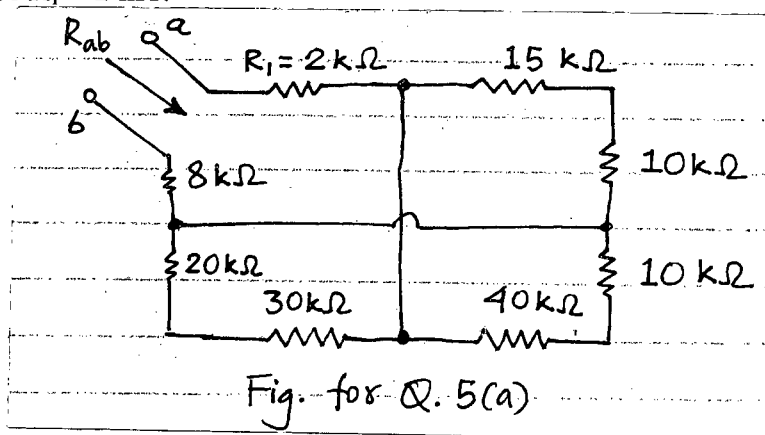

**EEE 155**

**Contd ... Q. No. 5**

(b) Derive the corresponding equations to transform a general 'Delta ( $\Delta$ )' resistive network to 'Wye ( $Y$ )' resistive network. (15)

6. (a) Use nodal analysis to find the voltages  $V_A$ ,  $V_B$  and  $V_C$  in the circuit of Fig. for Q. No. 6(a). (20)

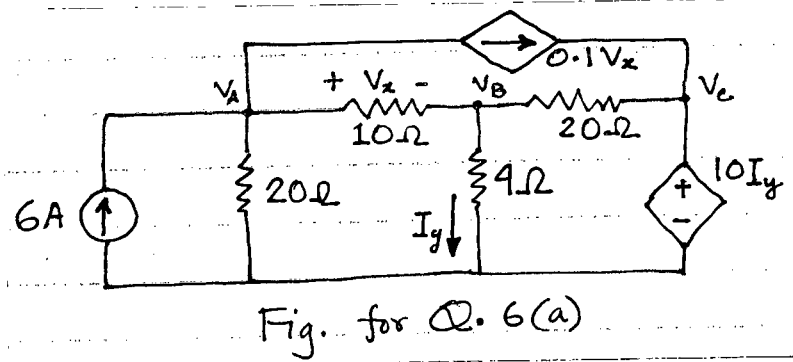

(b) Use mesh analysis to find the power dissipated in the resistance labelled  $R_1 = 500 \Omega$  in Fig. for Q. No. 6(b). (15)

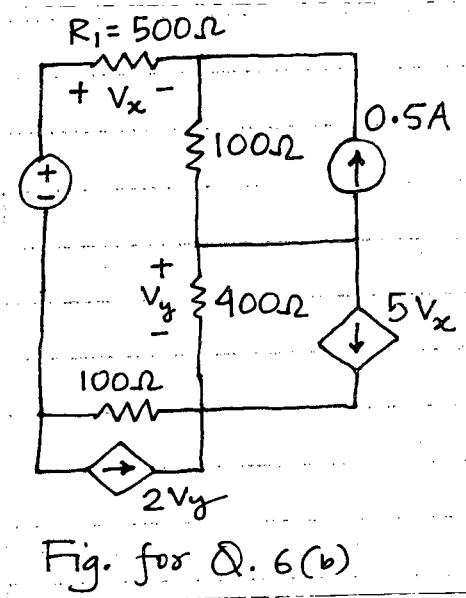

7. (a) Use source transformation to find  $i_x$  in the circuit of Fig. for Q. No. 7(a). (18)

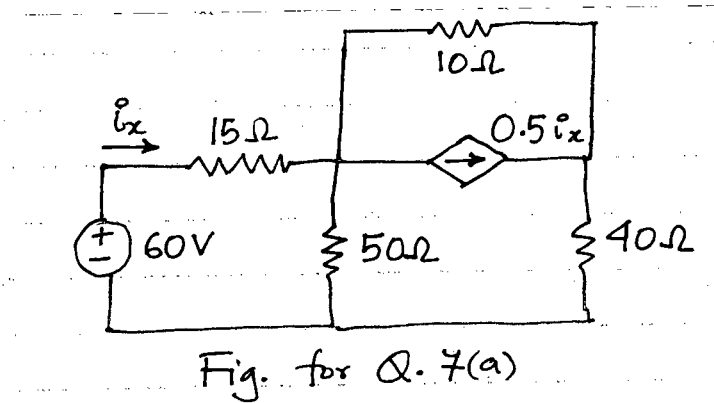

**EEE 155**

**Contd ... Q. No. 7**

(b) Determine  $v_0$  in the circuit of Fig. for Q. No. 7(b) using the superposition principle. (17)

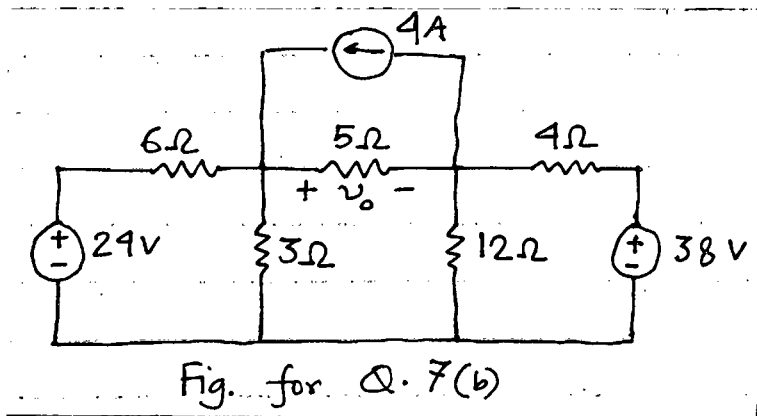

8. (a) Find the value of  $R_L$  for maximum power transfer in the circuit of Fig. for Q. No. 8(a). Also find the maximum power. (20)

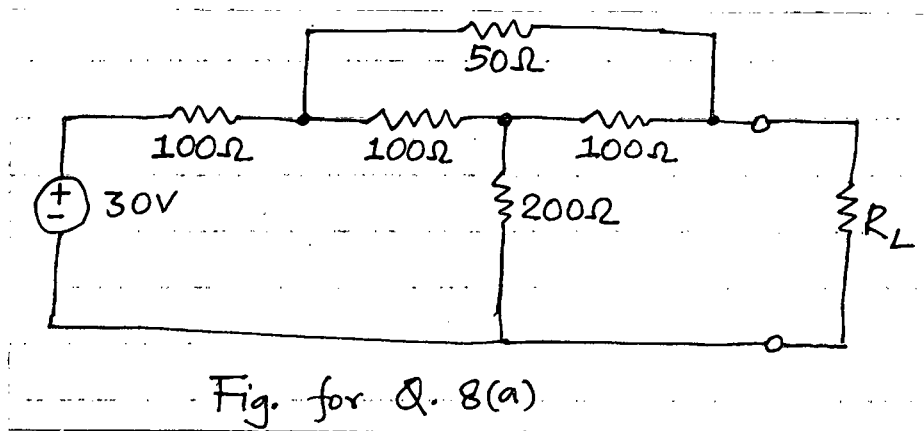

(b) Find the Norton equivalent circuit at terminals a – b in the circuit of Fig. for Q. No. 8(b). (15)

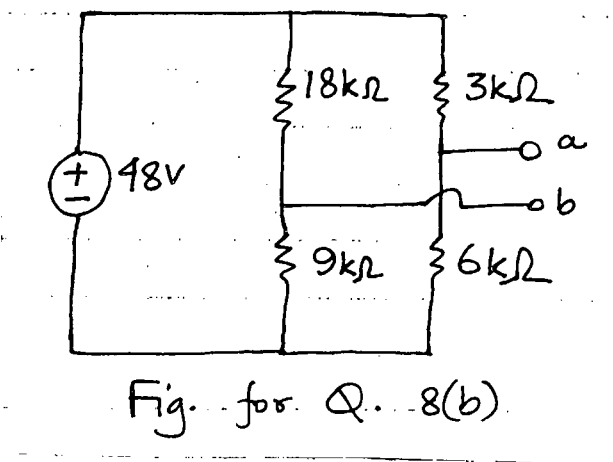

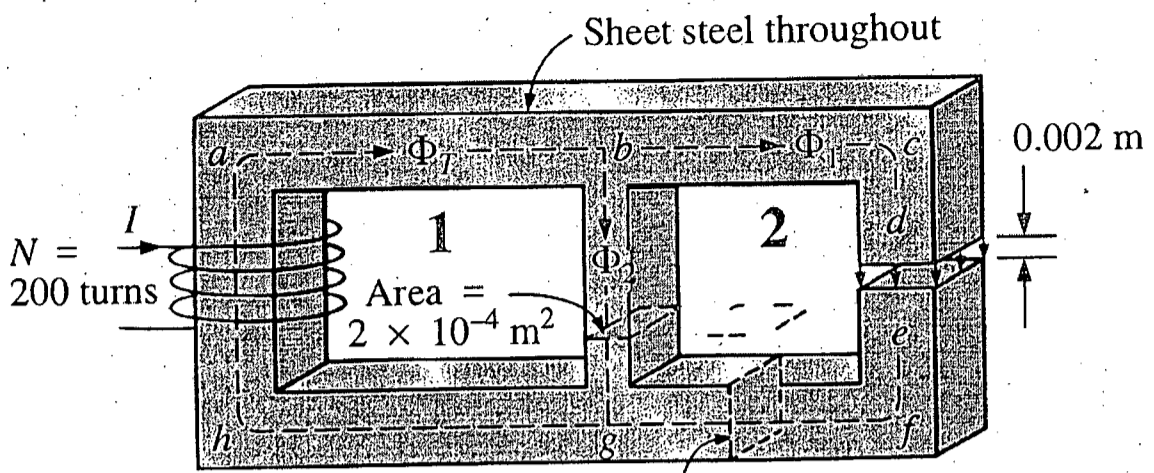

Area for sections other than  $bg = 5 \times 10^{-4} \text{ m}^2$

$l_{ab} = l_{ba} = l_{gh} = l_{ha} = 0.2 \text{ m}$

$l_{bc} = l_{fg} = 0.1 \text{ m}, l_{cd} = l_{ef} = 0.099 \text{ m}$

Fig. for Ques. No. 4(b)

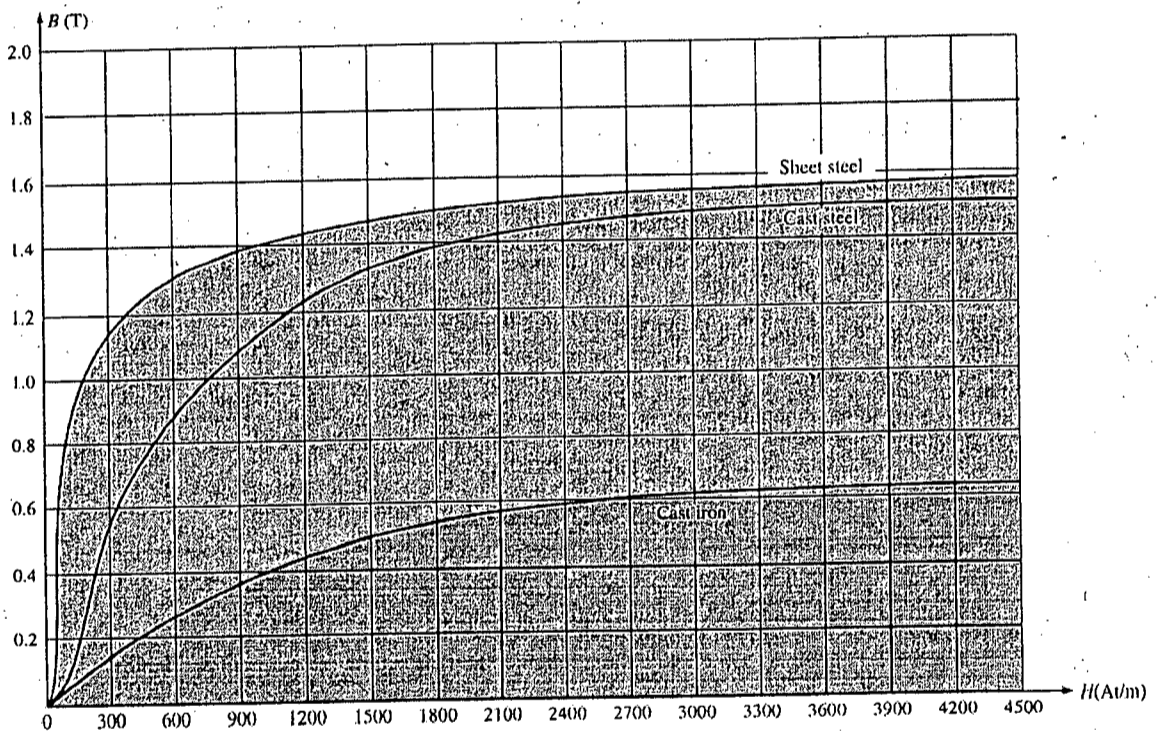

Magnetization curve