

SECTION – AThere are **FOUR** questions in this section. Answer any **THREE**.

1. (a) Show that the total average power of a balanced 3-phase. Wye-connected load can be measured by using only two wattmeters. (15)

(b) A Y-connected balanced three-phase generator with an impedance of $0.4 + j0.3 \Omega$ per phase is connected to a Y-connected balanced load with an impedance of $24 + j19 \Omega$ per phase. The line joining the generator and the load has an impedance of $0.6 + j.7 \Omega$ per phase. Assuming the abc sequence for the source voltages and that

$V_{an} = 120 \angle 30^\circ \text{ V}$, find: (20)

- (i) the line voltages,
- (ii) the phase currents,
- (iii) the total 3-phase average power, reactive power and apparent power.

2. (a) Draw the phasor diagrams of a single phase transformer at the secondary side by neglecting the effect of excitation at lagging, leading and unit power factor loads. From these phasor diagrams derive the formula for no-load voltage: (15)

$$\frac{V_p}{a} = V_s + R_{eq,s} I_s \cos \theta + X_{eq,s} I_s \sin \theta,$$

where symbols have their usual meanings.

How voltage regulation and efficiency of transformer are found?

- (b) A 1000 VA, 230/115-V transformer has been tested to determine its equivalent circuit. The results of the tests are shown below. (20)

Open-circuit test	Short-circuit test
$V_{OC} = 230 \text{ V}$	$V_{SC} = 19.1 \text{ V}$
$I_{OC} = 0.45 \text{ A}$	$I_{SC} = 8.7 \text{ A}$
$P_{OC} = 30 \text{ W}$	$P_{SC} = 42.3 \text{ W}$

- (i) Find the equivalent circuit of this transformer referred to the low-voltage side of the transformer.
 - (ii) Determine the transformer's efficiency at rated conditions and 0.8 PF lagging.
3. (a) What are the conditions of parallel operation of an alternator with an infinite bus? If the frequency of the oncoming generator is not same what is the solution? Why the frequency of the oncoming generator is kept little higher during synchronization? (15)

EEE 267 (CHE)
Contd... Q. No. 3

(b) A 480-V, 100-kW, 2-pole, three phase, 50 Hz alternator's prime mover has a no-load speed of 3630 rpm and a full-load speed of 3570 rpm. It is operating in parallel with a 480 V, 75 kW, 4-poles, 50 Hz alternator whose prime mover has a no-load speed of 1800 rpm and a full-load speed of 1785 rpm. The loads supplied by these two alternators consist of 100 kW at 0.85 PF (lagging). (20)

- (i) Calculate the speed droop of each alternator.
- (ii) Find the operating frequency of the power system.
- (iii) Find the power supplied by each alternator.

4. (a) Is a synchronous motor's field circuit in more danger of overheating when it is operating at a leading or at a lagging power factor? Explain, using phasor diagrams. (15)

(b) A 208-V, 45-kVA, 0.8-PF-leading, Δ -connected, 50 Hz synchronous machine has synchronous reactance of 2.5Ω and a negligible armature resistance. Its friction and windage losses are 1.5 kW, and its core losses are 1.0 kW. Initially, the shaft is supplying a 15-hp load, and the motor's power factor is 0.80 leading. (20)

- (i) Find the values of I_A , I_L and E_A and sketch the phasor diagram of this motor.
- (ii) If the shaft load is increased to 30 hp, then what will be the values of I_A , I_L and E_A . Sketch the behavior of the phasor diagram in response to this change.

SECTION – B

There are **FOUR** questions in this section. Answer any **THREE**.

5. (a) Derive an expression for the diode small signal resistance. When does small signal approximation valid? (15)

(b) Assuming ideal diode, find the values of I and V in the circuit shown in Fig. for Q. 5(b). (10)

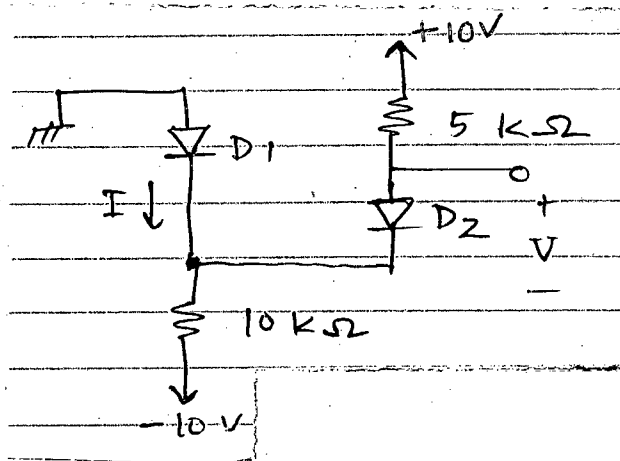

Fig. for Q. 5(b)

(c) Explain how Zener diode can be used as shunt regulator. (10)

EEE 267 (CHE)

6. (a) Explain with necessary graph why a BJT has to operate in active mode to be used as a linear-amplifier. (10)
- (b) How a BJT can be used as a switch? (10)
- (c) Determine all the node voltages and branch current in the circuit shown in Fig. for Q. 6(c). (15)

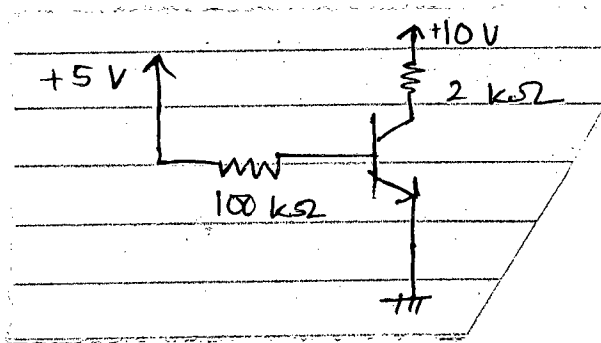

Fig. for Q. 6(c)

7. (a) A 460 V, 25 HP, 60 Hz, 4-pole, Y-connected induction motor has following impedances in ohm per phase referred to stator circuit: (20)

$$R_1 = 0.641 \Omega, \quad R_2 = 0.332 \Omega, \quad X_1 = 1.106 \Omega$$

$$X_2 = 0.464 \Omega, \quad X_M = 26.3 \Omega$$

Assume total rotational losses are 1100 W and neglect other losses.

For a rotor slip of 2.2% at the rated voltage and frequency, find:

- (i) Stator current
 - (ii) Power factor
 - (iii) P_{conv} and P_{out}
 - (iv) τ_{ind} and τ_{load}
 - (v) Efficiency
- (b) Suppose a shunt DC motor is operated on rated voltage, power and field current and running at 1200 rpm at this condition. Briefly explain the methods of speed control if you want to run the motor at 1000 rpm and 1500 rpm. (15)
8. (a) Briefly explain with necessary graph how voltage is buildup in a shunt DC generator. Write down several possible cases for the voltage to fail to build-up during starting. (15)
- (b) Design a circuit with op-amp so that it can perform following operation (20)

$$V_o = -5V_a + 4V_b + V_c,$$

where V_a, V_b, V_c are the input voltages and V_o is the output voltage.

Sub : **MATH 221** (Vector Analysis, Matrices and Laplace Transforms)

Full Marks: 280

Time : 3 Hours

USE SEPARATE SCRIPTS FOR EACH SECTION

The figures in the margin indicate full marks.

Symbols used have their usual meaning.

SECTION – AThere are **FOUR** questions in this section. Answer any **THREE**.

1. (a) If M and N are the middle points of AB and CD of the parallelogram ABCD, prove that DM and BN are trisected by AC and AC is trisected by them as well. (20)
- (b) If \mathbf{a} , \mathbf{b} , \mathbf{c} are non-coplanar vectors then prove that the following four points are coplanar: (16 $\frac{2}{3}$)
- $-\mathbf{a} + 4\mathbf{b} - 3\mathbf{c}$, $3\mathbf{a} + 2\mathbf{b} - 5\mathbf{c}$, $-3\mathbf{a} + 8\mathbf{b} - 5\mathbf{c}$, $-3\mathbf{a} + 2\mathbf{b} + \mathbf{c}$
- (c) Give the geometrical interpretation of the scalar triple product. (10)
2. (a) Show that acceleration of a particle along a curve is a vector in the plane of the tangent and the normal with $\frac{dv}{dt}$ and $v^2\kappa$ as its tangential and normal components respectively. (26 $\frac{2}{3}$)
- (b) Find the curvature, principal normal and binormal vectors of the space curve $r(t) = \cosh t\mathbf{i} + \sinh t\mathbf{j} + t\mathbf{k}$. (20)
3. (a) Find the equation of the tangent plane and the normal line to the surface (15)
- $z = 2x^2 - 3y^2$ at the point $A(1, -1, -1)$.
- (b) Show that the gradient of a scalar function f is a vector along the normal to the level surface whose magnitude is the greatest rate of change of f . (16 $\frac{2}{3}$)
- (c) Find curl of \mathbf{F} where $\mathbf{F} = (x^2 - y^2 + 2xz)\mathbf{i} + (xz - xy + yz)\mathbf{j} + (z^2 + x^2)\mathbf{k}$. Also show that the vectors given by curl \mathbf{F} at the points P(1, 2, -3) and Q(2, 3, 12) are orthogonal. (15)
4. (a) State and verify Green's theorem in the plane for $\int_C (2x - y^3)dx - xydy$ where C is the boundary of the region enclosed by $x^2 + y^2 = 1$ and $x^2 + y^2 = 4$. (26 $\frac{2}{3}$)
- (b) Evaluate $\iiint_V (2x + y)dV$ where V is the closed region bounded by the cylinder $z = 4 - x^2$ and the planes $x = 0$, $y = 0$, $y = 2$ and $z = 0$. (20)

MATH 221/CHE

SECTION – B

There are **FOUR** questions in this section. Answer any **THREE**.

5. (a) Determine the values of a for which the system has no solution, exactly one solution,

$$\begin{aligned} x + y + 7z &= -7 \\ 2x + 3y + 17z &= -16. \\ x + 2y + (a^2 + 1)z &= 3a \end{aligned}$$

(16 $\frac{2}{3}$)

- (b) Using elementary row transformations find the inverse of the matrix

(18)

$$A = \begin{bmatrix} 1 & 2 & -2 & -1 \\ -1 & -4 & 4 & 1 \\ 2 & -7 & 4 & -7 \\ 1 & 6 & -5 & 1 \end{bmatrix}$$

- (c) If A and B are symmetric matrices, then prove that AB is symmetric if and only if A and B commute.

(12)

6. (a) Reduce the real quadratic form $q = x_1^2 + 2x_2^2 - 2x_3^2 + 4x_1x_2 + 6x_3x_1$ to the canonical form and find the rank, index and signature of the form.

(14 $\frac{2}{3}$)

(b) Let $A = \begin{bmatrix} 1 & -3 & 3 \\ 3 & -5 & 3 \\ 6 & -6 & 4 \end{bmatrix}$;

- (i) Find the eigenvalues and corresponding eigenvectors.

(10)

- (ii) Is A diagonalizable? Justify your conclusion to find P , that diagonalizes the matrix A .

(10)

- (iii) Verify Cayley-Hamilton Theorem for the matrix A , and find A^{-1} .

(12)

7. (a) If $\mathcal{L}\{F(t)\} = f(s)$, then show that, $\mathcal{L}\{t^n F(t)\} = (-1)^n \frac{d^n}{ds^n} f(s)$, where $n = 1, 2, 3, \dots$

(16 $\frac{2}{3}$)

(b) Find $\mathcal{L}\left\{\frac{\cos \sqrt{t}}{\sqrt{t}}\right\}$

(15)

(c) Use Laplace transformation to evaluate $\int_0^{\infty} e^{-x^2} dx$.

(15)

8. (a) Find the following

(16)

(i) $\mathcal{L}^{-1}\left\{\frac{s}{(s^2 + a^2)^2}\right\}$ (ii) $\mathcal{L}^{-1}\left\{\frac{1}{\sqrt{s}(s-1)}\right\}$

- (b) Solve the following simultaneous differential equations using Laplace transformation:

(16 $\frac{2}{3}$)

$$\frac{dX}{dt} = 2X - 3Y$$

$$\frac{dY}{dt} = Y - 2X$$

Subject to $X(0) = 8, Y(0) = 3$.

- (c) Convert the following differential equation into integral equation.

(14)

$$Y''(t) + 2Y'(t) - 8Y(t) = 5t^2 - 3t, \quad Y(0) = -2, Y'(0) = 3.$$

BANGLADESH UNIVERSITY OF ENGINEERING AND TECHNOLOGY, DHAKA

L-2/T-1 B. Sc. Engineering Examinations 2015-2016

Sub : **CHE 201** (Material and Energy Balance)

Full Marks: 210

Time : 3 Hours

USE SEPARATE SCRIPTS FOR EACH SECTION

The figures in the margin indicate full marks.

SECTION – AThere are **FOUR** questions in this section. Answer **Q. No. 1** and any **TWO** from the rest.**Q. No. 1** is COMPULSORY.

1. (COMPULSORY) (a) Why boiler is used in a chemical process industry? Describe how firetube boilers and water tube boilers work. (7)
- (b) What is the 'Lever Rule'? Explain with appropriate diagram. (7)
- (c) Write a short note on differential and integral balance of a transient system. (6)
- (d) Describe the two approaches for computer aided process design. (6)
- (e) Determine (i) the absolute humidity (ii) wet bulb temperature (iii) humid volume (iv) Dew point (v) specific enthalpy of humid air at 47°C and 35% relative humidity. (9)

2. (a) The latest weather report includes the following statement: (17)
 "The temperature is 78°F, barometric pressure is 29.9 inches, and the relative humidity is 87%". From this information, estimate the mole fraction of water in the air and the dew point (°F), molal humidity, absolute humidity, and percentage humidity of the air. (17)
- (b) n-C₄H₁₀ is catalytically isomerized to iso-C₄H₁₀. A fresh feed stream containing pure n-butane at temperature T₁°C is mixed adiabatically with a recycle stream containing n-C₄H₁₀ and iso-C₄H₁₀, and the combined stream is fed to the reactor, where some but not all of the n-C₄H₁₀ in the feed is converted. The reactor effluent is pumped to a distillation column. The overhead distillation product contains primarily iso-C₄H₁₀ and a small amount of n-C₄H₁₀. The bottom product, which also contains both species, is the stream recycled to the reactor. Determine the number of degrees of freedom associated with the feed mixer, the reactor, the distillation column, and the entire process. Specify the design variables that must be known to solve the problem completely. (18)

3. A fuel gas containing 95 mole % methane and the balance ethane is burned completely with 25% excess air. The stack gas leaves the furnace at 900°C and is cooled to 450°C in a waste heat boiler, a heat exchanger in which heat lost by cooling gases is used to produce steam from liquid water for heating, power generation, or process applications. (35)

Contd P/2

CHE 201

Contd... Q. No. 3(a)

- (i) Taking as a basis of calculation 100 mol of the fuel gas fed to the furnace, calculate the amount of heat (kJ) that must be transferred from the gas in the waste heat boiler to accomplish the indicated cooling.
 - (ii) How much saturated steam at 50 bar can be produced from boiler feedwater at 40°C for the same basis of calculation?
 - (iii) At what rate (Kmol/s) must fuel gas be burned to produce 1250 kg steam per hour in the waste heat boiler? What is the volumetric flow rate (m³/s) of the gas leaving the boiler?
 - (iv) Briefly explain how the waste heat boiler contributes to the plant profitability.
4. (a) Fifty milliliters 100% H₂SO₄ at 25°C and 84.2 mL of liquid water at 15°C are mixed. The heat capacity of the product solution is 2.43 J/(g.°C). Estimate the maximum temperature attainable by the product solution and state the conditions under which this temperature would be attained. (17)
- (b) A 10 wt% aqueous solution of sodium chloride is fed to an evaporative crystallizer operated under a partial vacuum. Evaporation of water concentrates the remaining solution beyond its saturation point at the crystallizer temperature and causes crystallization of NaCl. The crystallizer product is a slurry of solute crystals suspended in a saturated solution at 80°C. The unit is to produce 1000 kg NaCl(s)/h. The solubility of NaCl in water is given in Figure for Q. 4(b). (18)
- (i) Derive expressions for the required rate of evaporation of water (kg/m) and the mass flow rate of solution in the exit slurry in terms of the mass flow rate of the feed stream to the crystallizer.
 - (ii) Determine the minimum possible feed rate and the corresponding values of the evaporation rate and exit solution flow rate.

SECTION – B

There are **FOUR** questions in this section. Answer any **THREE**.

Data booklet for CHE 201 is attached.

5. A double effect evaporator is used to produce fresh water from seawater containing 3.5 wt% dissolved salt. A flowchart of the process is shown in Fig. 5. Seawater enters the first effect at 300 K at a rate of 5000 kg/h and saturated steam at 4.0 bar absolute is fed into a tube bundle in the first effect. The steam condenses at 4.0 bar, and the condensate is withdrawn at the saturation temperature corresponding to this pressure. The operating pressures of the first and second effects are 0.6 bar and 0.2 bar, respectively. The exiting brine solution from the first effect contains 5.5 wt% salt. Assume brine solution from both effects have the same physical properties of water and the effects operate adiabatically.

CHE 201

Contd... Q. No. 5

- (a) Draw and label the flow chart including the temperature and specific enthalpy of each stream. (10)
- (b) At what rate must steam be fed in the first effect? (15)
- (c) What is the production rate of fresh water? What is the salt concentration of the final brine solution? (10)

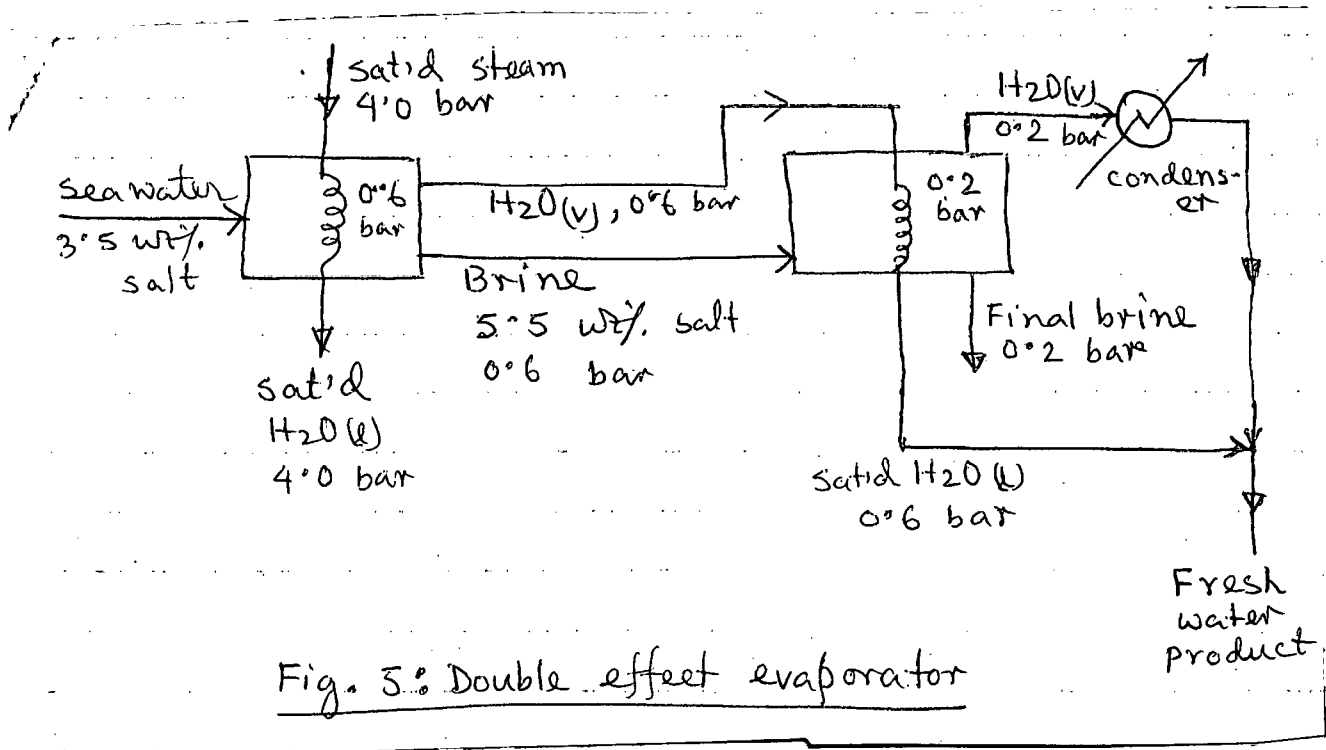

6. In a small pilot plant reactor, sulfur dioxide is oxidised to sulfur trioxide. Sulfur dioxide and 100% excess air are fed to the reactor at 400°C. The reaction proceeds to 75% SO₂ conversion, and the products emerge at 500°C. The production rate of SO₃ is 100 kg/min. The reactor is surrounded by a water jacket into which water at 25°C is fed. Calculate the heat in kW that must be transferred from the reactor to the cooling water. Find the minimum flow rate of cooling water, if its temperature rise is to be kept below 15°C. (30+5)
7. A flowchart for ethanol production is shown in Fig. 7. The steam input with fresh ethylene (96 mole% pure) is adjusted such a way that the combined feed composition is 54.75 mole% C₂H₄, 35.59% H₂O and the balance inerts. A single pass conversion of 5% ethylene is achieved in the reactor. The reaction is (35)

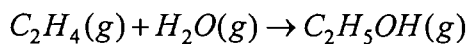

The output stream from the reactor is passed to a separator where all the ethanol and water are removed as product, and the off-gases are recycled back. In order to control the inert concentration in the combined feed to the reactor, a small quantity of the recycle stream is purged. For 100 kmol/h of fresh ethylene feed, calculate

CHE 201

Contd... Q. No. 7

- (i) the molar flow rate of purge stream.
- (ii) the composition and molar flow rate of the recycle stream.

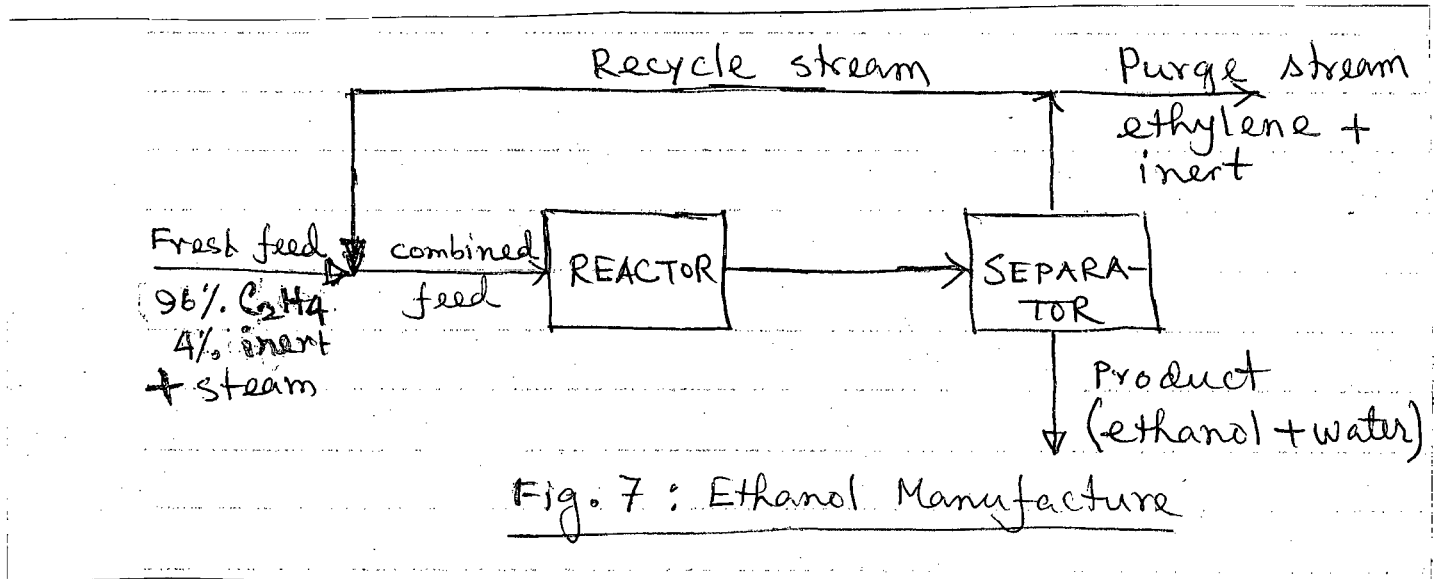

8. (a) A gas phase reaction with stoichiometry $2A \rightarrow 2B + C$ follows a second order rate equation, $r_A = kC_A^2$ (molA/m³.S), where C_A is the reactant concentration in molA/m³ and k is the rate constant. Suppose the reaction is carried out in a closed batch reactor of constant volume, V (m³) at a constant temperature T (K) beginning with pure A at concentration C_{A0} . Write a differential balance on A and integrate it to obtain an expression of $C_A(t)$ in terms of C_{A0} and k . If P_0 (atm) is the initial pressure of the reactor, prove that the time required to achieve a 50% conversion of A in the reactor equals to RT/kP_0 . Assume ideal gas behaviour. (17)

(b) If pure methane is burned with 10% excess air, what will be the adiabatic flame temperature? Assume inlet temperatures of both methane and air are 25°C. (18)

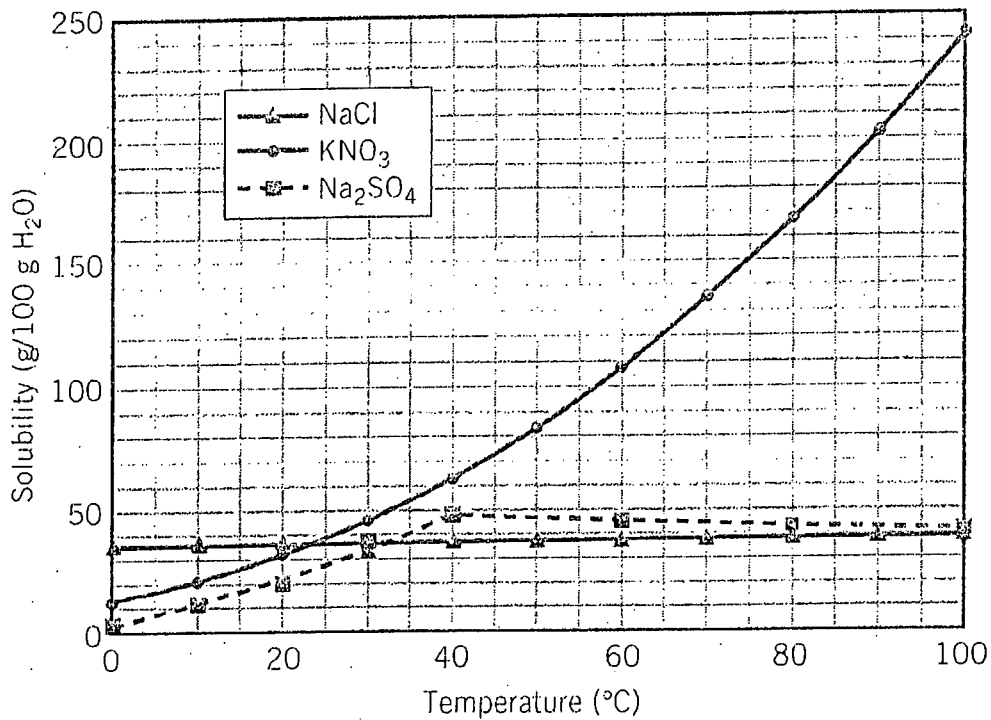

Figure for Q.4(b): Solubilities of inorganic solutes.

SECTION – A

There are **FOUR** questions in this section. Answer any **THREE**.

Assume reasonable values for any missing data.

1. (a) Rationalize the following: (6×5=30)
- (i) AC-source is used to measure the conductance of electrolyte solution.
 - (ii) Specific conductance increases but equivalent conductance decreases with increasing electrolyte concentration.
 - (iii) Kohlrausch's law is applied to measure the Λ° values of weak electrolytes.
 - (iv) H^+ and OH^- show abnormally high ionic mobilities.
 - (v) The activity coefficient initially decreases and then increases with increasing ionic strength of electrolyte solution.
- (b) The molar conductivities at infinite dilution of NaCl, HCl and CH_3COONa are 126.4, 426.1 and $91.0 \text{ ohm}^{-1}\text{cm}^2\text{mol}^{-1}$ respectively. What will be the value of Λ° for acetic acid? (5)
2. (a) Define the term 'hydrolysis'. Derive an expression for the hydrolysis constant of solution of a salt of a weak base and a strong acid. (10)
- (b) Define buffer capacity. Establish the conditions under which acidic and basic buffers work effectively. Under what condition a buffer solution show maximum buffer capacity? (17)
- (c) What will be the pH of a solution obtained by mixing 5.0 g of acetic acid and 7.5 g of sodium acetate and making the volume to 500 mL? (8)
3. (a) What are electrophoretic effect and relaxation effect? (10)
- (b) Derive Debye-Huckel limiting law. Applying the law show that the solubility of a sparingly soluble salt increases with increasing the concentration of an added electrolyte having no common ion. (17)
- (c) Calculate the ionic strength and mean activity coefficient of a 2:1 electrolyte at a molality of 0.001 in aqueous solution at 25°C . (8)
4. (a) Define reversible and irreversible cells. (8)
- (b) What is meant by junction potential? Show that the sign and magnitude of the junction potential depends on the transference numbers of the anion and the cation. (12)
- (c) Explain how you can determine the thermodynamic parameter from cell emf measurement. (7)
- (d) The emf of the cell (8)
- $$\text{Ag}|\text{AgCl(s)}|\text{KCl(aq)}|\text{Hg}_2\text{Cl}_2(\text{s})|\text{Hg}$$
- is $+0.0455 \text{ V}$ at 25°C and the temperature coefficient is $+3.38 \times 10^{-4} \text{ V deg}^{-1}$. What is the reaction taking place in the cell and what are the enthalpy and entropy changes at 25°C ?

CHE 235**SECTION – B**

There are **FOUR** questions in this section. Answer any **THREE**.

5. (a) Define half-life of a reaction. Why the concept of half-life is important? Show that the concept of half-life can be applied for the determination of order of a reaction. (3+4+8=15)
- (b) What are the basic assumptions in collision theory? 'A reaction of forth or higher order is improbable' — Justify the statement with collision theory. (8+4=12)
- (c) What is a parallel reaction? Draw the reaction profile for the following parallel reaction when (i) $k_1 > k_2$ and (ii) $k_2 > k_1$. (3+5=8)

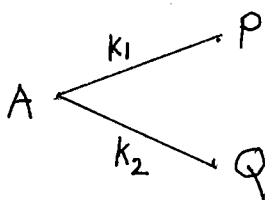

6. (a) What are the origins of absorption spectra for inorganic compounds in the analysis by UV-Vis spectroscopy? (12)
- (b) Explain (i) Amines absorb at higher wavelength as compared to alcohols (ii) the orange color of $\text{Cr}_2\text{O}_7^{2-}$ is not due to d-d transitions. (3+4=7)
- (c) Infrared spectra is a finger print of a molecule — Explain. Show that asymmetric stretching of CO_2 is infrared active. (8+8=16)
7. (a) What is multilayer adsorption? Why solid surface follows multilayer adsorption rather than monolayer? How BET considers multilayer adsorption model? (3+6+8=17)
- (b) Select and discuss two important chemical processes where the concept of adsorption is important. (10)
- (c) What is a catalytic promoter? Explain the activity of promoters in catalysis process by applying adsorption theory. (8)
8. (a) Derive the phase rule where P is the phase C is component and F is degrees of freedom. What are the number of phases and components in the following system (i) A saturated solution of NaCl (ii) A heterogeneous mixture of this type $\text{MgCO}_3(\text{s}) \rightleftharpoons \text{MgO}(\text{s}) + \text{CO}_2(\text{g})$. (10+4=14)
- (b) What is a metastable equilibrium? Show a suitable phase diagram when a metastable equilibrium exist. (7)
- (c) Draw and explain the phase diagram of water and CO_2 system. Compare the diagram and explain that CO_2 sublimates at room temperature but ice does not. (14)

SECTION – A

There are **FOUR** questions in this section. Answer any **THREE**.

1. (a) Draw the P-V diagram of a typical pure substance. Show important points and areas on the diagram. (10)
- (b) The Vander Walls equation of state is given by (13)

$$\left(P + \frac{a}{V^2}\right)(V - b) = RT$$
 where, a and b are constants for the given substance. Show that

$$a = \frac{27R^2T_c^2}{64P_c} \text{ and } b = \frac{RT_c}{8P_c}$$
- (c) Derive the Clapeyron-Clausius equation. (start from basic equation) (12)
2. (a) Discuss the basic ideas behind the second law of thermodynamics. (9)
- (b) Write the two official statements of the second law of thermodynamics. (6)
- (c) Show that the above two statements are equivalent. (5)
- (d) Prove that the absolute temperature scale based on ideal gas is actually a thermodynamic temperature scale. (15)
3. (a) Write the background observations that lead to the discovery of "entropy". (8)
- (b) What is the physical meaning of entropy? Discuss with examples. (7)
- (c) Write a few lines on the "principle of increasing entropy". (8)
- (d) What is co-generation? With a simple diagram describe the operation of a co-generation plant. (12)
4. (a) Derive the expression for the thermal efficiency of a air-standard ideal diesel cycle. (13)
- (b) Describe the working of a basic Rankine power cycle. (9)
- (c) Discuss the different ways of improving the efficiency of a basic Rankine power cycle. (13)

SECTION – B

There are **FOUR** questions in this section. Answer any **THREE**.

5. (a) Starting from basic definition show that (12)

$$\Delta S = \int_{T_1}^{T_2} \frac{C_v}{T} dT + \int_{V_1}^{V_2} \left(\frac{\delta P}{\delta T} \right)_V dV$$

- (b) Write a short note on Joule-Thomson co-efficient (include inversion temperature and related terms in your answer). (10)

- (c) Discuss the modifications that are used over the basic cycle to improve the efficiency of gas-turbines. Elaborate your answer by using P-V and T-S diagrams. (13)

6. (a) Write a few words to elaborate the statement "the second law of thermodynamics indicates that energy has quality as well as quantity". (12)

- (b) Describe the working principle of a simple vapor-compression refrigeration cycle. Use proper thermodynamic diagrams to explain how refrigeration is obtained in the above cycle. (13)

- (c) Write a short account on how to select the right refrigerant for a given situation. (10)

7. (a) State and explain the increase of entropy principle? (6)

- (b) Discuss the meaning of "entropy" from molecular viewpoint. Include Boltzmann relation and the third law of thermodynamics in your discussion. (15)

- (c) A 25 kg iron block ($C_p = 0.465 \text{ kJ/kg}^\circ\text{C}$) initially at 350°C is quenched in an insulated tank that contains 100 kg water at 18°C . Assuming no water vaporize during the process, determine the total entropy change during the process. (14)

8. (a) How does reversible work differ from useful work? Explain with examples. (9)

- (b) What is the second-law of efficiency? How does it differ from the first-law efficiency? (7)

- (c) A heat engine that receives heat from a furnace at 1200°C and rejects waste heat to a river at 20°C has a thermal efficiency of 40 percent. Determine the second-law of efficiency of this engine. (7)

- (d) Which is a more valuable resource for work production in a closed system – (12)

0.3 m^3 of air at 700 kPa and 150°C or 0.6 m^3 of helium at 550 kPa and 95°C ? Surrounding temperature is 25°C and pressure is 100 kPa.

Substance	Molar mass kg/kmol	Gas constant, R kJ/kg.k	C_p kJ/kg.k	C_v kJ/kg.k
Air	28.97	0.2870	1.005	0.718
Helium	4.003	2.0769	5.1926	3.1156
