

The figures in the margin indicate full marks.

Symbols used have their usual meaning.

USE SEPARATE SCRIPTS FOR EACH SECTION

**SECTION – A**

There are **FOUR** questions in this section. Answer any **THREE**.

1. (a) Determine the relationships among the constants p, q and r under which the following system has unique solution and infinite solution (if any). (16<sup>2</sup>/<sub>3</sub>)

$$x + 2y - 3z = p$$

$$3x - y + 2z = q$$

$$x - 5y + 8z = r$$

- (b) Find the canonical matrix and hence find the rank of the matrix  $A = \begin{bmatrix} 2 & 7 & 3 & 5 \\ 1 & 2 & 3 & 4 \\ 3 & 8 & 1 & -2 \\ 4 & 13 & 1 & -1 \end{bmatrix}$ . (18)

- (c) If A and B are non-singular square matrices, then prove that (i)  $(AB)^{-1} = B^{-1}A^{-1}$  and (ii)  $(A^{-1})^T = (A^T)^{-1}$ . (12)

2. (a) Using elementary row transformations find the inverse of the matrix  $\begin{bmatrix} 1 & 4 & 3 & 1 \\ 0 & 5 & 4 & 3 \\ 2 & 5 & 3 & 1 \\ 0 & 1 & 2 & 0 \end{bmatrix}$ . (20)

- (b) Find the eigenvalues and corresponding eigenvectors of matrix A. Find a matrix P

that diagonalizes the matrix A and also find  $P^{-1}AP$ , where  $A = \begin{bmatrix} 0 & 0 & -2 \\ 1 & 2 & 1 \\ 1 & 0 & 3 \end{bmatrix}$ . (26<sup>2</sup>/<sub>3</sub>)

3. (a) Examine whether the followings are subspace or not: (16<sup>2</sup>/<sub>3</sub>)

(i)  $S = \{(x, y, z) : 3x + 2y - z = 0\}$

(ii)  $S = \{(x, y, z) : x^2 \geq 1\}$

- (b) Find standard basis vectors for  $\mathbf{R}^4$  that can be added to the set  $(\mathbf{v}_1, \mathbf{v}_2)$  to produce a basis for  $\mathbf{R}^4$ , where  $\mathbf{v}_1 = (1, -4, 2, -3)$ ,  $\mathbf{v}_2 = (-3, 8, -4, 6)$ . (15)

- (c) Let  $\mathbf{T} : \mathbf{R}^3 \rightarrow \mathbf{R}^3$  be a linear transformation, where  $\mathbf{T}(x, y, z) = (x + 2y + z, y + z, x + y - 2z)$ , then find the basis of  $\mathbf{Im}(\mathbf{T})$  and  $\mathbf{Ker}(\mathbf{T})$ , also find rank and nullity of  $\mathbf{T}$ . (15)

= 2 =

**MATH 243/CSE**

4. (a) Prove that if two vectors are linearly dependent, one of them is a scalar multiple of the other. Examine whether the vectors  $\mathbf{u} = (8, -1, 3)$  and  $\mathbf{v} = (4, 0, 1)$  are linearly dependent or independent. (18)
- (b) Find a unit vector parallel to the plane containing the vectors  $2\mathbf{i} - \mathbf{j} + 2\mathbf{k}$  and  $3\mathbf{i} - 2\mathbf{j} - \mathbf{k}$  but perpendicular to  $2\mathbf{i} + 5\mathbf{j} - 3\mathbf{k}$ . (16  $\frac{2}{3}$ )
- (c) Find the volume of the parallelepiped whose edges are represented by  $\mathbf{a} = 2\mathbf{i} - 3\mathbf{j} + 4\mathbf{k}$ ,  $\mathbf{b} = \mathbf{i} + 2\mathbf{j} - \mathbf{k}$ , and  $\mathbf{c} = 3\mathbf{i} - \mathbf{j} + 2\mathbf{k}$ . (12)

**SECTION - B**

There are **FOUR** questions in this section. Answer any **THREE**.

5. (a) Find the equation of the tangent line and normal plane to the curve of intersection of (12)  
 $x^2 + y^2 + z^2 = 1$  and  $x + y + z = 1$ , at  $(1, 0, 0)$   
Also, find the angle between the surfaces.
- (b) Verify Green's theorem in the plane for  $\oint_C (xy + y^2) dx + x^2 dy$ , where C is the closed curve of the region bounded by  $y = x$  and  $y = x^2$ . (12)
- (c) State and prove Stokes' theorem. Verify Stokes' theorem for  $\mathbf{A} = (2x - y)\mathbf{i} - yz^2\mathbf{j} - y^2z\mathbf{k}$ , where S is upper half surface of the sphere  $x^2 + y^2 + z^2 = 1$  and C is its boundary. (22  $\frac{2}{3}$ )
6. (a) Show that  $L \left\{ \operatorname{erf}(\sqrt{t}) \right\} = \frac{1}{s\sqrt{s+1}}$ , where  $\operatorname{erf}(t)$  is the error function. (15  $\frac{2}{3}$ )
- (b) State Heaviside's expansion formula and using this formula evaluate (16)

$$L^{-1} \left\{ \frac{3s+1}{(s-1)(s^2+1)} \right\}$$

- (c) Using Laplace Transform show that  $\int_0^{\infty} \cos x^2 dx = \frac{1}{2} \sqrt{\frac{\pi}{2}}$ . (15)

7. (a) Use the Laplace transform to solve the given initial-value problem: (13  $\frac{2}{3}$ )

$$y'' + y = f(t), y(0) = 1, y'(0) = 0$$

where  $f(t) = \begin{cases} 1, & 0 \leq t < \frac{\pi}{2} \\ \sin t, & t \geq \frac{\pi}{2} \end{cases}$

Contd ..... P/3

**MATH 243/CSE****Contd ... Q. No. 7**

(b) Solve the following system:

**(15)**

$$L \frac{di_1}{dt} + Ri_2 = E(t)$$

$$RC \frac{di_2}{dt} + i_2 - i_1 = 0$$

under the conditions  $E(t) = 60$  V,  $L = 1$  h,  $R = 50 \Omega$ ,  $C = 10^{-4}$  f, and the currents  $i_1$  and  $i_2$  are initially zero.

(c) Solve the following system of differential equations using Laplace Transform

**(18)**

$$\frac{dx}{dt} + \frac{dy}{dt} = t$$

$$\frac{d^2x}{dt^2} - y = e^{-t}; \quad x'(0) = -2, \quad y(0) = 0, \quad x(0) = 3$$

8. (a) Find the Fourier series for

**(16 $\frac{2}{3}$ )**

$$f(x) = \begin{cases} x + \frac{\pi}{2} & -\pi < x < 0 \\ \frac{\pi}{2} - x & 0 \leq x < \pi \end{cases}$$

Hence find the sum:  $\frac{1}{1^2} + \frac{1}{3^2} + \frac{1}{5^2} + \dots$

(b) Solve the integral equation,  $\int_0^{\infty} f(t) \cos ut \, dt = \begin{cases} 1-u, & 0 \leq u < 1 \\ 0, & u > 1 \end{cases}$ . Hence show that

$$\int_0^{\infty} \frac{\sin^2 u}{u^2} \, du = \frac{\pi}{2}. \quad (10)$$

(c) Use finite Fourier transformation to solve

**(20)**

$$\frac{\partial u}{\partial t} = \frac{\partial^2 u}{\partial x^2}, \quad 0 < x < 6, \quad t > 0, \quad u(0, t) = u(6, t) = 0$$

$$u(x, 0) = \begin{cases} 1; & 0 < x < 3 \\ 0; & 3 < x < 6 \end{cases}$$

Also give a physical interpretation of the solution.

-----

**SECTION – A**

There are **FOUR** questions in this section. Answer any **THREE**.

Use sketch where necessary.

1. (a) What is 'Shikhara'? Show the changes in Shikhara of North Indian temples through sketches. (8 1/3)
- (b) Illustrate the distinctive features of Khajuraho group of temples. (15)
2. (a) Discuss the theme and layout of the Sun temple at Konarak. Show the evidences to justify why it appears to be 'never completed'. (13 1/3)
- (b) Draw the different parts of a typical Orissan temple with necessary sketches. (10)
3. (a) What can you tell us about 'Gopuram'? (5)
- (b) What were the underlying thoughts that generated the 'Fort' like planning layout of Madurai temple? (10)
- (c) Write about 'Vastu Purusha Mandala'. (8 1/3)
4. (a) Evaluate Durga temple as 'the adoption of apsidal ended Chaitya hall for Hindu Worship' by the Chalukyan builders. (10)
- (b) It was a 'Double Towered Monument' with unusual position and 'plan was not according to custom – justify in relation to Shore temple. (13 1/3)

**SECTION – B**

There are **FOUR** questions in this section. Answer any **THREE**.

5. (a) Name the principal contribution made by Asokan School of Art and Architecture. (3)
- (b) Briefly write about 'Sonsara' and 'Nirvana'. (8 1/3)
- (c) Illustrate Asokan pillar in relation to 'Wheel of Law". (12)

**ARCH 243**

6. (a) 'Rock cut caves were sculptures on a grand and magnificent scale' – Explain. (10)  
(b) What is a Chaitya Hall? Write about the main features of Karli, which is considered as the climax of Chaitya Hall architecture. (13  $\frac{1}{3}$ )
7. (a) Write down the basic difference between the marble stupa at Amravati and the stupa at Sanchi. (5  $\frac{1}{3}$ )  
(b) "The great stupa at Sanchi culminates the solution of stupa development" – Explain with sketches. (18)
8. (a) Write about the 'Frescos of Ajanta'. (8  $\frac{1}{3}$ )  
(b) Illustrate the plan and three dimensional features of the monastic sanctuary Takht-i-Bahai at Taxila. (15)
-

**SECTION – A**

There are **FOUR** questions in this section. Answer any **THREE**.

1. (a) Design a DFA  $M$  with alphabet  $\Sigma = \{0, 1, 2, 3, R\}$ , which recognizes the language  $A$ . The language  $A$  is the set of all strings where the sum of the numbers is a multiple of 3, except that the sum is reset to 0 whenever the symbol  $R$  appears. Only a diagrammatic description of  $M$  should suffice. (10)
- (b) For the DFA in Question 1(a) we change the alphabet to  $\Sigma = \{0, 1, 2, R\}$ , and you decide to use the states to remember actual sums of the numbers. Show diagrammatically how this DFA can be constructed. What is the problem with this DFA? Explain clearly. (13  $\frac{1}{3}$ )
2. (a) Use pumping lemma for regular languages to find out, whether the unary language,  $\{1^{n^2} \mid n \geq 0\}$ , is a regular language or not. (10)
- (b) Design a DFA which accepts all and only the binary number strings divisible by 4. Explain how the DFA works. (13  $\frac{1}{3}$ )
3. (a) Design an NFA over the alphabet  $\Sigma = \{a, b\}$  which accepts all and only the strings of nonzero length having nonzero even number of  $a$ 's at the end. (13  $\frac{1}{3}$ )  
Thus, this NFA will accept,  $aa, aaaa, abbaa, abaababaaaa$ , but will reject,  $aaa, ab, b, abbaaa$  and  $abaabbbb$ .
- (b) Provide regular expressions generating the following languages. (4+3+3)
  - (i)  $\Sigma = \{0, 1, 2, 3, 4, 5, 6, 7, 8, 9\}$ . The members of this language are numbers divisible by 5. A number cannot start with a 0 except for standalone 0s.
  - (ii) Binary strings consisting of either an odd number of 0s (and any number of 1s) or an odd number of 1s (and any number of 0s).
  - (iii) Binary strings that do not contain the sequence 101 embedded anywhere.
4. (a) Construct an NFA over the alphabet  $\Sigma = \{0, 1\}$  that accepts the set of strings that contain an even number of occurrences of substring 01. Then convert this NFA to an equivalent DFA. Give only the portion of the DFA that is reachable from the start state. (7  $\frac{1}{3}$  +4)
- (b) State and prove pumping lemma for regular language. First, explain your ideas about the proof and then carry out the actual proof. (12)

**CSE 211****SECTION - B**

There are **FOUR** questions in this section. Answer any **THREE**.

5. (a) Consider the following context free grammar: (7)
- $$S \rightarrow abScB \mid \varepsilon$$
- $$B \rightarrow bB \mid b$$
- What language does it generate?
- (b) Construct context free grammars to accept the following languages over  $\Sigma = \{0, 1\}$ : (7)
- (i)  $\{w \mid w \text{ starts and ends with the same symbol}\}$ .
- (ii)  $\{w \mid |w| \text{ is odd and its middle symbol is } 0\}$ .
- (c) What is Chomsky normal form? convert the following context free grammar into an equivalent free grammar in Chomsky normal form: (9 1/3)
- $$A \rightarrow BAB \mid B \varepsilon$$
- $$B \rightarrow 00 \mid \varepsilon$$
6. (a) Explain why the context free grammar below is ambiguous: (7)
- $$S \rightarrow 0A \mid 1B$$
- $$A \rightarrow 0AA \mid 1S \mid 1$$
- $$B \rightarrow 1BB \mid 0S \mid 0$$
- (b) Show that the following language over  $\Sigma = \{a, b, c\}$  is not context free: (7)
- $$L = \{a^n b^j c^k : k = jn\}.$$
- (c) Construct the state diagram of a pushdown automaton that recognizes the following language  $L = \{wcw^R \mid w \in \{a,b\}^* \text{ and } w^R \text{ is the reverse of } w\}$ . Trace the computation that accepts "bbcbb" by configuration. (9 1/3)
7. (a) Prove that for any pushdown automaton P, there exists a context free grammar G such that  $L(P) = L(G)$ . (7)
- (b) Prove that the set of infinite binary sequences is not countable. (7)
- (c) Prove that a non-deterministic Turing machine is equivalent to a deterministic Turing machine. (9 1/3)
8. (a) What do you mean by decidable, Turing recognizable, and undecidable languages? (7)
- (b) Let  $L = \{w - w \mid w \in \{a, b\}^*\}$  be a language. Draw a state diagram of a Turing machine that decides L. (7)
- (c) Prove that the language  $A_{TM} = \{\langle M, w \rangle \mid M \text{ is a Turing machine accepting } w\}$  is undecidable. (9 1/3)
-

**SECTION - A**

There are **FOUR** questions in this section. Answer any **THREE**.

1. (a) State the parenthesis theorem for the depth-first search. Prove the theorem. (10)  
 (b) Find the different types of edges if DFS is applied to the following graph from vertex A. Discuss the edges' properties with respect to the following graph. (7)

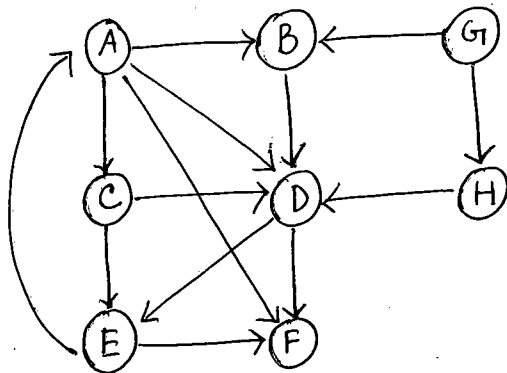

Fig : Q.1 (b)

- (c) Show the topological sorting order of the graph in Question 1(b) with explanation of discovery and finishing time of the node exploration. [Note: There will be no edge from E to A]. (8)  
 (d) Let C and C' be distinct strongly connected components in directed graph  $G = (V, E)$ . Suppose that there is an edge  $(u, v) \in E$ , where  $u \in C$  and  $v \in C'$ , then prove that  $f(C) > f(C')$ , where  $f(U)$  = the latest finishing time of any vertex in U. (10)

2. (a) Let  $G = (V, E)$  be a connected, undirected graph with a real-valued weight function  $w$  defined on E. Let A be a subset of E that is included in some minimum spanning tree for G, let  $(S, V-S)$  be any cut that 'respects' A and let  $(u, v)$  be a "light" edge crossing  $(S, V-S)$ . Then prove that edge  $(u, v)$  is "safe" for A. (8)  
 (b)

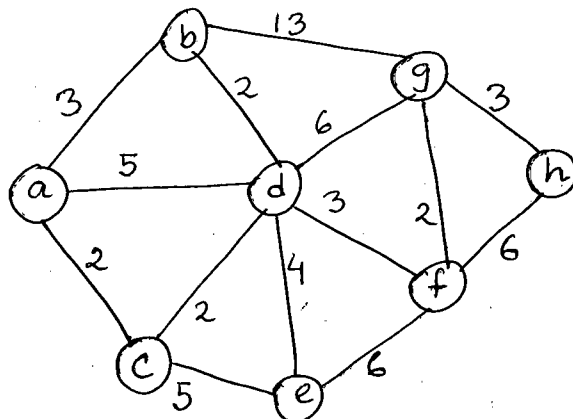

Fig : Q. 2 (b)



**CSE 207**

**Contd ... Q. No. 2(b)**

Find the "light" and "respectful" crossing edges for each step of Kruskal's method for building MST of the graph shown in Figure for Q. 2(b). (12)

(c) What will be the cost of finding and joining (union) of sets in Kruskal's method? (5)

(d) For the graph in Q. 2(b), show the value of u, v.key, Q for the following algorithm (show each step) (10)

```

MST (G, w, r)
  Q = V[G]
  for each u ∈ Q
    u.key = ∞
  r.key = 0, p[r] = NULL
  while (Q ≠ empty)
    u = extract min (Q)
    for each v ∈ Adj [u]
      if ((v ∈ Q) and w(u,v) < v.key)
        p[v] = u
        v.key = w(u, v)
    
```

3. (a) State and prove the convergence property of edge relaxation in the context of shortest paths. (5)

(b) Provide the correctness proof of the Dijkstra's algorithm. (10)

(c) Find the transitive closure for the following graph. Show the matrices computed at each step. What will be the cost to find the transitive closure? (10)

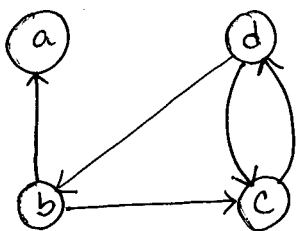

Fig: Q. 3 (c)

(d) Apply Belman-Ford algorithm to the following graph to find the shortest paths. Show the relaxation. (10)

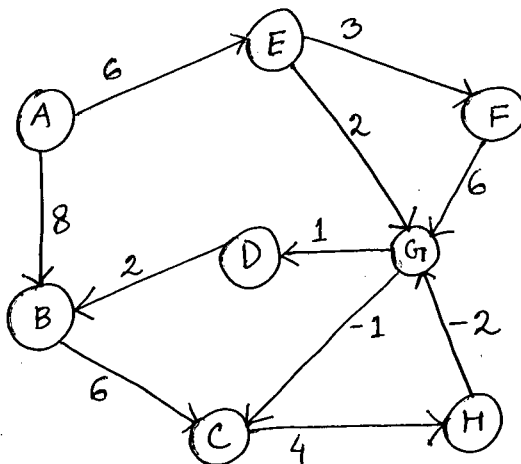

Fig: Q. 3 (d)

**CSE 207**

4. (a) A traffic engineer needs to decide to widen the road for allowing maximum traffic from A to G for the following road-network. Which roads are to be widened? (12)

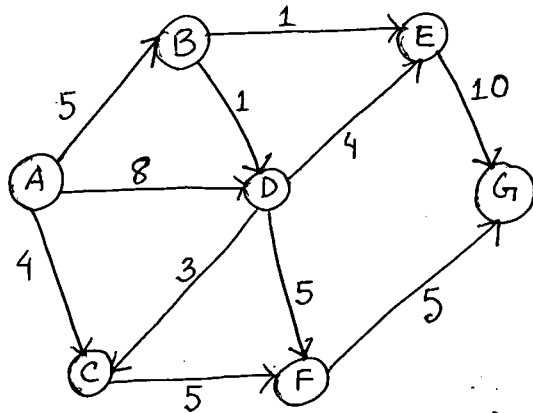

Fig. Q. 4 (a)

- (b) Define and explain super sink node, augmented path, residual capacity, super source node in a network flow model. (8)
- (c) What is the pitfall of Ford-Fulkerson's max-flow-min-out method? How can it be improved? (5)
- (d) Find the maximum job assignment for the following graph. (10)

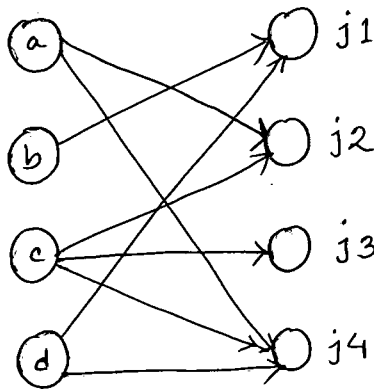

Fig. Q. 4 (d)

**SECTION - B**

There are **FOUR** questions in this section. Answer any **THREE**.  
All the symbols have their usual meanings unless explicitly mentioned.

5. (a) What is asymptotic analysis of algorithms? Define big  $O$ -notation,  $\Omega$ -notation and  $\Theta$ -notation. Accordingly, for the following functions:  $f(n) = n \log n$  and  $g(n) = 10n \log 10n$ , show whether  $f$  is  $O(g)$ , or  $f$  is  $\Omega(g)$ , or  $f$  is  $\Theta(g)$ . (3+6+8)
- (b) State master theorem. Explain why master method cannot be used to solve the following recurrence:  $T(n) = 2T(n/2) + n \log n$ . Using substitution method, prove that  $T(n)$  is  $O(n \log^2 n)$ . (6+6+6)

**CSE 207**

6. (a) *GreedyCell*, a mobile phone operator, wants to place cell towers (base stations) along a long straight country road, to provide network coverage to  $n$  houses sparsely scattered along the road. The distance of these houses from the start of the road are, in miles and in increasing order,  $d_1, d_2, \dots, d_n$ . Each cell tower has coverage of  $R$  miles, i.e., if a house is within  $R$  miles of a tower, it would get service from that tower. Now give an efficient algorithm for finding a placement of cell towers that uses as few cell towers as possible to provide coverage to all the  $n$  houses. (12)
- (b) Given a sorted array of distinct integers  $A[1 \dots n]$ , we want to find out whether there is an index  $i$  for which  $A[i] = i$ . Give a divide-and-conquer algorithm that runs in time  $O(\log n)$ . Write the pseudocode of the algorithm and then prove the runtime based on that code. (12)
- (c) Prove that the lower bound on any comparison-based sorting is  $n \log n$ , i.e., any comparison sort algorithm requires  $\Omega(n \log n)$  comparison in the worst case. (11)
7. (a) What are the key properties of an optimization problem such that the problem can be solved using dynamic programming? Compare top-down memorized dynamic programming with bottom-up dynamic programming and identify the types of problems for which one outperforms the other. (4+4)
- (b) The balanced partition problem is defined as follows. Given a set of  $n$  integers, each in the range  $[0, N]$ , we want to divide the set into two subsets such that difference of sum of the two subsets is minimum. For example, for the set of integers:  $S = \{1, 7, 3, 5, 9\}$ , a balanced partition will be the subsets,  $S_1 = \{1, 7, 5\}$  and  $S_2 = \{3, 9\}$  since for this partition, the difference of sum of numbers on  $S_1$  and  $S_2$  is 1 which is the minimum. Now, formulate a dynamic programming solution for the balanced partition problem. Determine the time complexity of your algorithm. (15)
- (c) Consider the following instance of the maximum satisfiability (MAX-SAT) problem. (12)
- Set of Boolean variables,  $V = \{w, x, y, z\}$   
 Set of clauses,  $C = \{C_1, C_2, C_3, C_4, C_5, C_6\}$   
 where  $C_1 = (w \vee \bar{x} \vee \bar{y} \vee z)$ ,  $C_2 = (w \vee \bar{y})$ ,  $C_3 = (x \vee \bar{y})$ ,  $C_4 = (y \vee \bar{z})$   
 $C_5 = (z \vee \bar{w})$ ,  $C_6 = (\bar{w} \vee \bar{x})$
- Now find an assignment of variables such that maximum number of clauses is satisfied. Compute your solution using branch and bound algorithm. Write down a suitable bound function for the problem. Show detailed calculation steps through a branch and bound search tree.
8. (a) Define the following classes of problems: P, NP and NP-complete. (8)
- (b) What are the steps to prove a problem X is NP-Complete? Prove that decision version of independent set problem is NP-complete using reduction from 3-CNF satisfiability (3-CNF-SAT or 3-SAT) problem. (3+12)
- (c) Give a sketch (intuitive explanation) of the proof of Cook-Levin theorem which states that circuit-satisfiability (CIRCUIT-SAT) problem is NP-Complete. (12)

-----

**SECTION – A**

There are **FOUR** questions in this section. Answer any **THREE**.

1. (a) Draw the I-V characteristics curve of a real diode. Find out the transfer function for the given circuit and input (Fig. 1(a)) and draw the transfer function. Please use piecewise linear model for diodes ( $V_\gamma = 0.7 \text{ V}$  and  $R_f = 100 \Omega$ ). (15)
- (b) Find out the range(s) of input for which both D1 and D2 diodes will be forward biased in Fig. 1(b). Also, find out the output of the circuit in this scenario. Consider piecewise linear model for diodes ( $V_\gamma = 0.7 \text{ V}$  and  $R_f = 100 \Omega$ ). (10)
- (c) For any periodic input waveform, what should be the average level of the steady state output of a Low Pass RC circuit? Provide mathematical analysis to support your answer. (10)
  
2. (a) The signal shown in Fig. 2(a)-1 is fed to the circuit of Fig. 2(a)-2 as input. Derive output equation and draw the output wave shape. Use  $R = 1 \text{ K}\Omega$  and  $C = 1 \mu\text{F}$ . You can assume no initial capacitor voltage. (10)
- (b) Find out the output equation if the signal shown in Fig. 2(a)-1 is fed to the circuit of Fig. 2(b)-2 as input. Find out the relationship between output curve and input curve, and mathematically prove that relationship. Use  $R = 1 \text{ K}\Omega$  and  $C = 1 \mu\text{F}$ . You can assume no initial capacitor voltage. [You can use the general formula to find out the output equation.] (10)
- (c) Write down the difference(s) between transient analysis and steady state analysis of RC circuits. How can RC circuits be used as an integrator or a differentiator? (15)
  
3. (a) Design a square wave generator, which is an astable multivibrator. Write down the transition conditions (low to high and vice versa) of your generator. (15)
- (b) What are the features of a Schmitt trigger? Represent a scenario where Schmitt trigger performs better than a normal comparator. (10)
- (c) Find out the transmission error for a ramp input in High Pass RC circuit, where RC is very large compared to T ( $RC \gg T$ ). (10)
  
4. (a) Consider the triangular wave generator shown in Fig. 4(a)-1. The output is shown in Fig. 4(a)-2. Write down the equation for  $V_1$  and mathematically derive the values of positive sweep time and negative sweep time. You can use the given values of  $V_{\max}$  and  $V_{\min}$  is needed. (10)

$$V_{\max} = (R_2/R_1) * v_0 + (R_1 + R_2)/R_1 * v_R$$

$$V_{\min} = -(R_2/R_1) * v_0 + (R_1 + R_2)/R_1 * v_R$$

**CSE 209**

**Contd ... Q. No. 4**

(b) Design a 4-bit inverted ladder Digital to Analog Converter (DAC). Clearly draw the circuit diagram and derive the output equation. (15)

(c) Write down the disadvantages of weighted resistance DAC. What can we do if the input of weighted resistance DAC is given in 1's complement form? (10)

**SECTION - B**

There are **FOUR** questions in this section. Answer any **THREE**.

5. (a) For each transistor in Figure 5(a), assume that  $f_{HE} = 100$ ,  $V_{BE(sat)} = 0.75V$ ,  $V_{\gamma} = 0.65V$  and  $V_{CE(sat)} = 0.2V$  at  $\sigma = 0.85$ . The drop across each conducting diode is  $0.75V$  and  $V_{\gamma}(\text{diode}) = 0.65V$ . The inputs are obtained from the outputs of similar gates. **(5+5+8+6+5)**

- (i) Calculate  $\Delta 0$  noise margin when T2 unloaded.
- (ii) Calculate  $\Delta 1$  noise margin when T2 is unloaded.
- (iii) Calculate fan-out of the gate.
- (iv) Keeping the temperature of the environment fixed, suggest the simplest modification of the circuit to increase the  $\Delta 0$  noise margin.
- (v) Draw the input-output characteristics curve of the modified circuit.

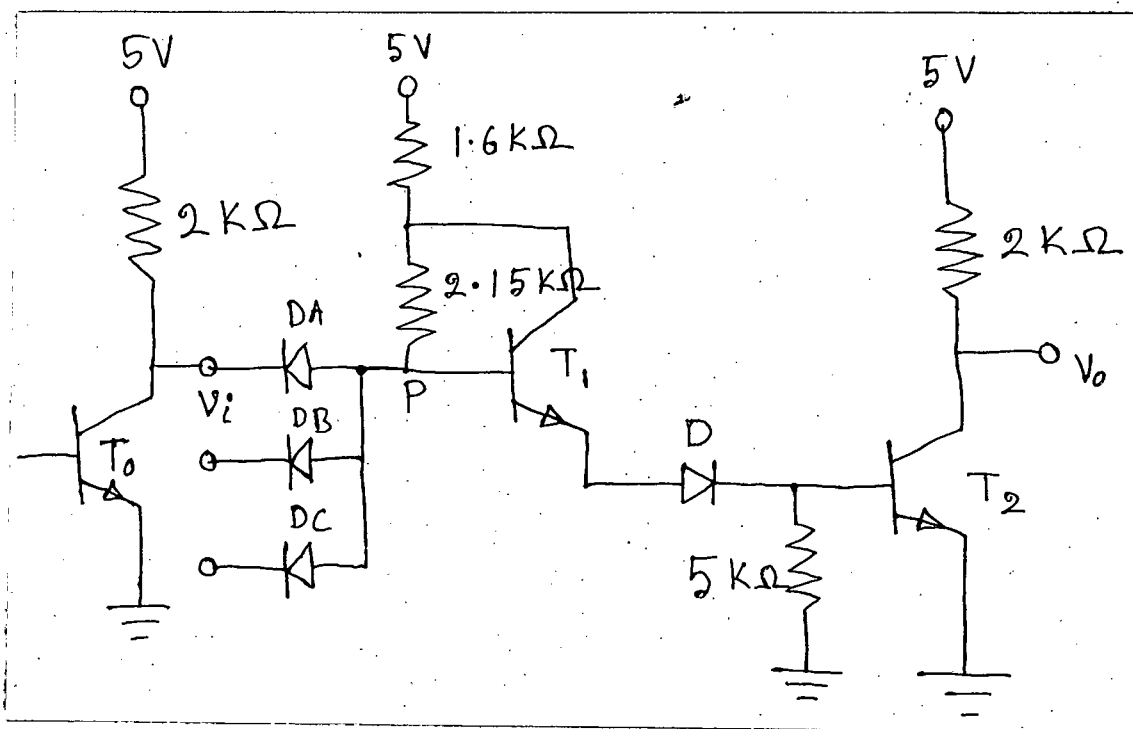

Figure - 5 (a)

(b) Draw the basic circuit of an ECL OR-NOR gate. (6)

**CSE 209**

6. (a) Briefly explain the active pull-up mechanism of TTL logic family. Explain the advantages of TTL logic family over DTL logic family. **(10+8)**
- (b) Draw the basic circuit of an HTL inverter. Derive and illustrate its input-output characteristics. Mention the assumed values required in your derivation. **(5+7)**
- (c) Explain the WIRED-AND connection of two 3-input NAND gates. **(5)**
7. (a) Draw the voltage transfer curve of a CMOS inverter. In your figure, mention the modes of operation of the p-channel and the n-channel in different regions of the curve. **(8)**
- (b) Simplify the following function in POS form and implement the simplified function using **(10+10)**
- (i) NMOS gates only
- (ii) PMOS gates only
- $$f(A, B, C, D) = \sum m (1, 2, 4, 5, 6, 9, 12, 13) + d (0, 11, 15)$$
- You can use both positive and negative literals.
- (c) Draw the circuit diagram of a CMOS SR flip-flop. **(7)**
8. (a) draw the block diagram of basic RAM organization. **(6)**
- (b) Draw a 4-MOSFET dynamic RAM cell with refresh circuit. Briefly explain its operation. **(6+6)**
- (c) Compare MOS/CMOS logic gates with BJT logic gates in terms of power consumption. **(7)**
- (d) Draw the basic circuits of a 2-input diode AND gate and a 2-input RTL NOR gate. **(5+5)**
-

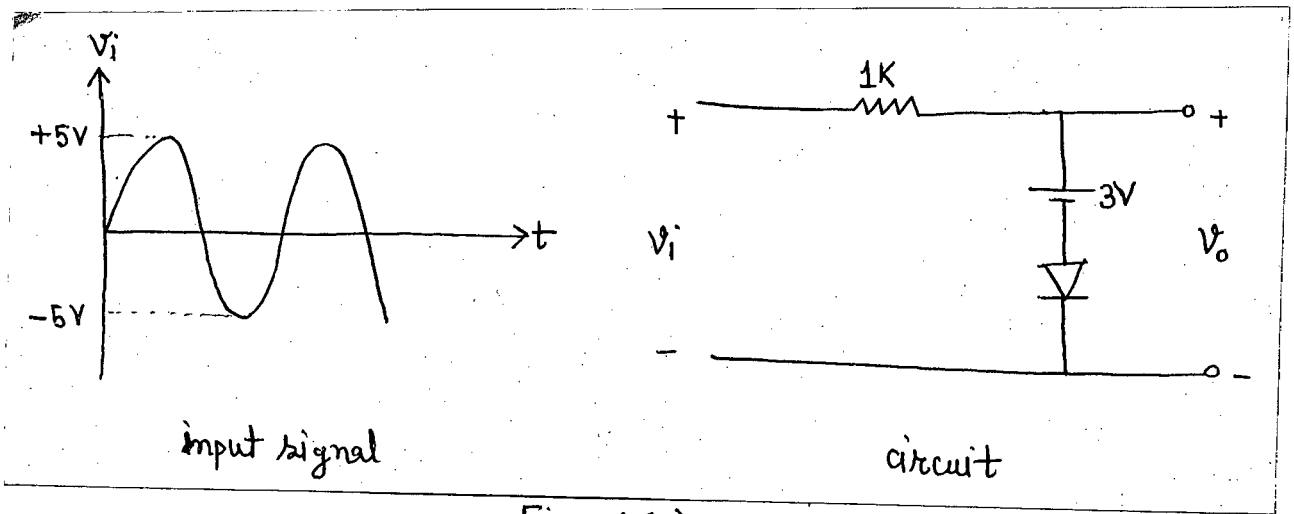

Fig. 1(a)

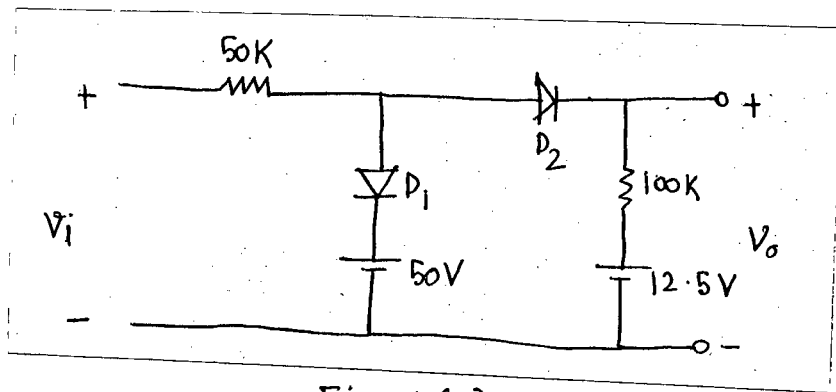

Fig. 1(b)

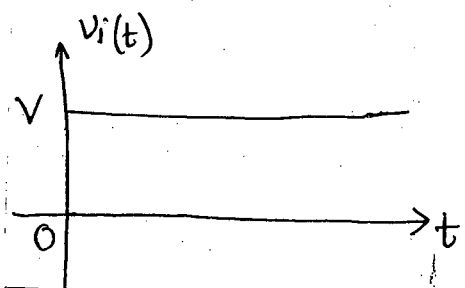

Fig. 2(a)-1 : step voltage input

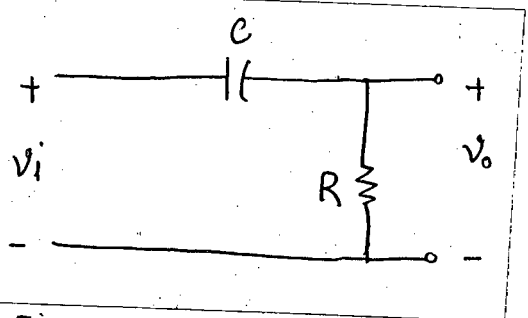

Fig. 2(a)-2 : Circuit

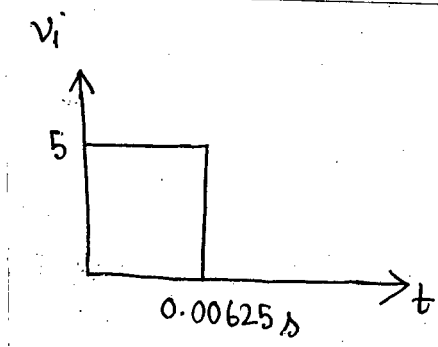

Fig. 2(b)-1 : Pulse input

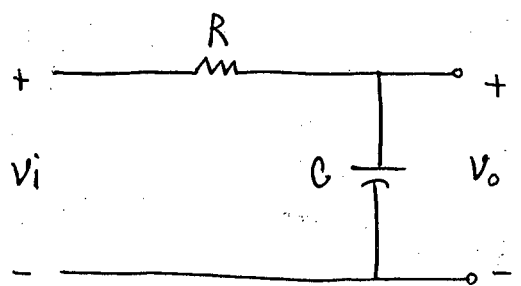

Fig. 2(b)-2 : Circuit

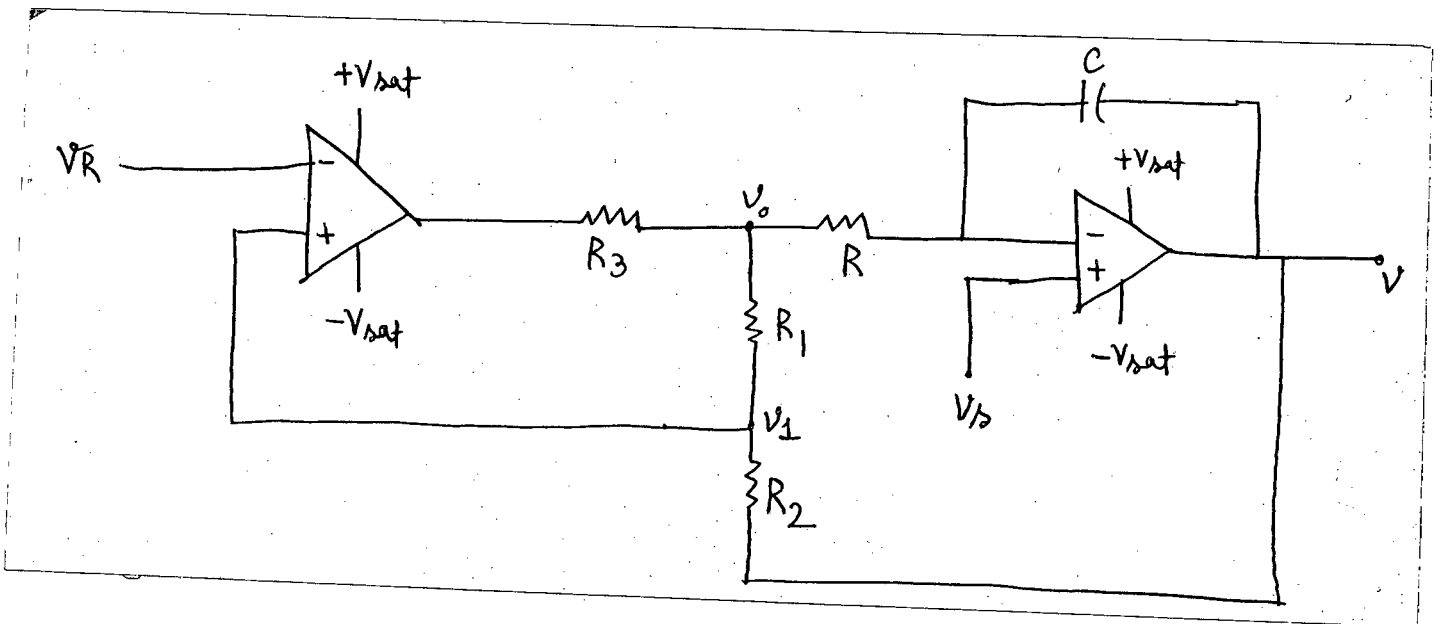

Fig. 4(a) - 1

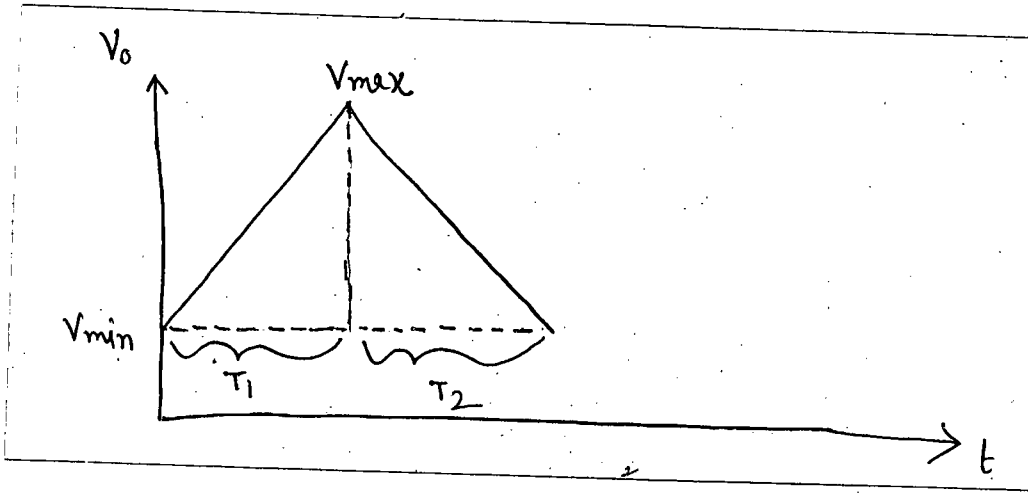

Fig. 4(a) - 2



**SECTION - A**

There are **FOUR** questions in this section. Answer any **THREE**.

If any question has missing data, make a reasonable assumption and state it in your solution.

1. (a) Under what conditions is a three phase electrical power system more economical than a single phase system? Provide analysis for your answer. (18)

- (b) A three-phase electrical circuit is presented in Fig. for Q. 1(b), where  $\bar{Z}_\Delta = 21 + 24j \Omega$ . Find all the ac power components for the line and the load sections of the circuit. Explain the significance of the average power components of your answer. (17)

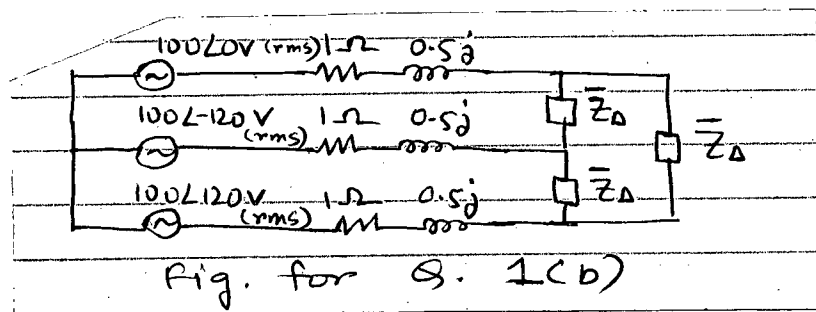

2. (a) The circuit in Fig. for Q. 2(a) is powered by a balanced three phase supply with a line voltage of 210 V. The different impedance components of the circuit are given as  $Z_1 = (1 + j) \Omega$ ,  $Z_\Delta = (24 - 30j) \Omega$  and  $Z_Y = (12 + 5j) \Omega$ . Determine the magnitude of the current ( $I_b$ ) as shown in the figure and the total real power absorbed by the line sections. Comment on the configuration of the three phase supply of this system. (20)

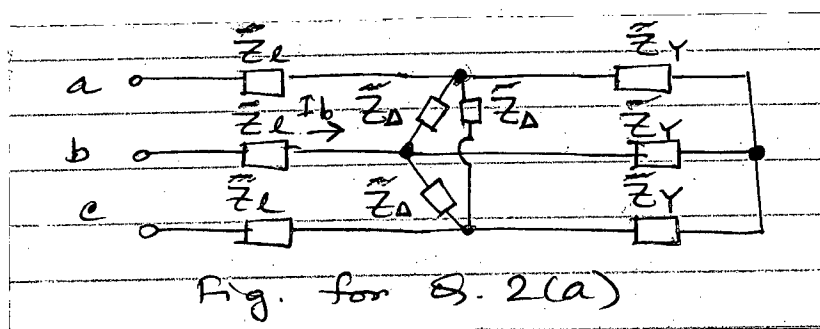

- (b) Explain why and how a single phase transformer can be used as an impedance multiplier. (15)

**EEE 269/CSE**

3. (a) Derive the expression  $E = 4.44 Nf\phi_{max}$  for transformer voltages where the symbols have their usual meaning. Also, derive the approximate equivalent transformer circuit (referred to the secondary side) using basic assumptions. (18)
- (b) The open-circuit and short-circuit test data (performed in a standard manner) for a 75 kVA, 4600/230 V, 50 Hz transformer are given below: (17)

<u>Open-circuit Test</u>	<u>Short-circuit Test</u>
$V_{OC} = 230 \text{ V}$	$V_{SC} = 160.8 \text{ V}$
$I_{OC} = 13.04 \text{ A}$	$I_{SC} = 16.3 \text{ A}$
$P_{OC} = 521 \text{ W}$	$P_{SC} = 1200 \text{ W}$

Determine (i) the approximate equivalent circuits of the transformer referred to high-tension side and low-tension side, (ii) the transformer efficiency when operating at rated load and 0.75 power factor (lagging).

4. (a) With clear diagrams, explain the concept of 'useful force' behind dc motor action. Why is commutation necessary for a dc motor and how is it achieved? (20)
- (b) A 25 hp, 250 V series motor has an armature resistance of  $0.1 \Omega$ , a brush voltage drop of 3 V, and a series field resistance of  $0.05 \Omega$ , when the motor draws a current of 85 A, its speed is 600 rpm. (15)
- (i) Calculate the motor speed when the current drawn by the motor is 100 A.
- (ii) Also, calculate the speed when the motor current is 40 A. Comment on the relationship between motor current and motor speed. Assume that the motor is operating on the linear portion of its saturation curve.

**SECTION – B**

There are **FOUR** questions in this section. Answer any **THREE**.

5. (a) What is 'static', 'alternating' and 'rotating' magnetic field? What is the significance of rotating magnetic field in rotary machines? Explain how a rotating magnetic field is established in a synchronous generator and also in a synchronous motor. (15)
- (b) A synchronous machine has a synchronous reactance of  $2.0 \Omega$  per phase and negligible armature resistance. If  $E_A = 500 \angle 5.98^\circ \text{ V}$  and  $V_\phi = 480 \angle 0^\circ \text{ V}$ , determine whether this machine is operating as a generator or a motor? How much real and reactive power is this machine consuming from or supplying to the electrical system? (10)

**EEE 269/CSE**

**Contd ... Q. No. 5**

(c) A thermocouple circuit uses a Chromel-Alumel couple which gives an emf of 33.3 mV while measuring a temperature of 800°C with reference to 0°C. The resistance of the meter coil,  $R_m$  is 50  $\Omega$  and 0.1 mA current gives full deflection. Resistance of junction and leads,  $R_E$  is 12  $\Omega$ .

(10)

- (i) Calculate the value of series resistance,  $R_S$  if a temperature of 800°C is to give full scale deflection.
- (ii) Calculate the approximate error due to rise of 1  $\Omega$  in  $R_E$ .
- (iii) What will be the approximate error in the above condition if  $R_S = 0$ ?

6. (a) What is synchronous speed? Explain why an induction motor cannot operate at synchronous speed whereas a synchronous motor always operates at synchronous speed.

(8)

(b) A 30 hp, three-phase, 12 pole, 460 V, 60 Hz  $\Delta$ -connected induction motor operating at off-rated load draws a line current of 35 A with a power factor of 80% and efficiency of 90%. Stator conductor loss, rotor conductor loss, and core loss are 850 W, 485 W and 415 W, respectively.

(15)

Determine:

- (i) Input power
- (ii) Shaft horsepower
- (iii) Rotor frequency
- (iv) Shaft speed
- (v) Shaft torque
- (vi) Combined friction, windage and stray loss

(c) An electronic voltmeter shown in Fig. for Q. 6(c) has the following specifications:  $R_D = 15 \text{ k}\Omega$ , ac drain resistance = 100  $\text{k}\Omega$ , and transconductance = 0.003 mho. If the meter has a resistance of 1800  $\Omega$  and a full scale current of 5 A, what is the input voltage at the gate of the left FET required to produce full scale current when the gate of the right FET is grounded?

(12)

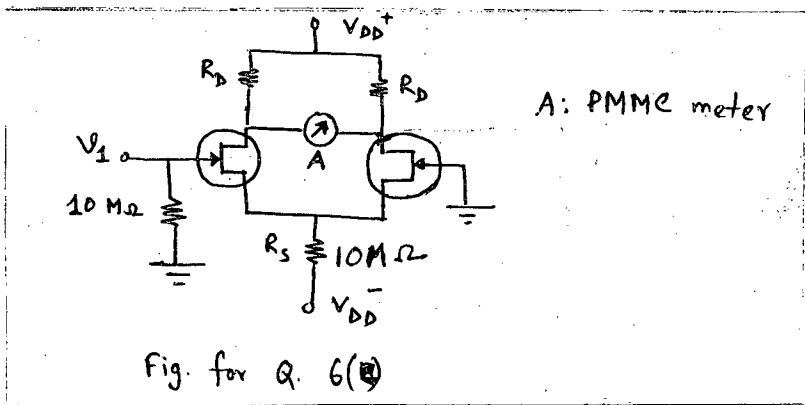

**EEE 269/CSE**

7. (a) Design an optoelectronic transducer that can drive a large load when the illumination level crosses a certain threshold. Briefly explain the operation of the designed circuit. (10)

(b) At a location in Bangladesh, it is necessary to supply 500 kW of 60-Hz power, but frequency of the national grid is 50 Hz. How is it possible to solve this problem using a synchronous motor-generator set? Determine the minimum no. of poles in both machines to convert 50-Hz power to 60-Hz power? (10)

(c) A 400 V, 100 kW, 50 Hz, four-pole, Y-connected synchronous motor has a rated power factor of 0.85 leading. At full load, the efficiency is 90%. The synchronous reactance is  $1.0 \Omega$  and the armature resistance is negligible. The combined friction-windage, stray and core loss can be considered constant irrespective of load change. Find the following quantities for this machine when it is operating at rated condition. (15)

(i) Output torque

(ii)  $E_A$  and  $I_A$

(iii)  $P_{f,w} + P_{core} + P_{stray}$

If the shaft load is now reduced to 80 kW, what will be its efficiency?

8. (a) Draw the circuit diagram of a differential amplifier and an instrumentation amplifier. What are the advantages of instrumentation amplifier over differential amplifier. Explain piezo-electric effect in brief. (10)

(b) Explain why transformation ratio of a current transformer deviates from its turns ratio. How can this deviation be minimized? (10)

(c) A 480 V, 60-Hz, Y-connected, six-pole synchronous generator has a per-phase synchronous reactance of  $1.0 \Omega$  and negligible armature resistance. At full load, friction-windage losses are 1.5 kW and core losses are 1.0 kW. The field circuit has been adjusted so that the terminal voltage is 480 V at no-load. Stray loss is 1% of the input power. (15)

(i) If the generator terminals are connected to a  $\Delta$ -connected load with an impedance of  $18\angle 30^\circ$  per phase, what will be its efficiency and torque applied by the prime mover?

(ii) If the load is changed and the new load draws a current of 60 A at 0.8 leading pf, what will be its regulation?

-----