

L-2/T-2/ARCH

Date : 08/01/2013

BANGLADESH UNIVERSITY OF ENGINEERING AND TECHNOLOGY, DHAKA

L-2/T-2 B. Arch. Examinations 2010-2011

Sub : **HUM 119** (Psychology)

Full Marks : 140

Time : 3 Hours

The figures in the margin indicate full marks.

USE SEPARATE SCRIPTS FOR EACH SECTION

SECTION - A

There are **FOUR** questions in this section. Answer any **THREE**.

1. (a) What are the goals of psychology? (6)
(b) Compare different approaches to psychology. (17 1/3)
2. (a) Differentiate between absolute and difference thresholds with appropriate examples. (6)
(b) Discuss how we organize our perception according to Gestalt law. (17 1/3)
3. (a) What is the relationship between motivation and frustration? (6)
(b) Describe the approaches to motivation. (17 1/3)
4. (a) What are the functions of emotion? (6)
(b) Draw a chart showing the classification of emotion. (17 1/3)

SECTION - B

There are **FOUR** questions in this Section. Answer any **THREE**.

5. (a) What is observational learning? (6)
(b) What are the roles of reinforcement and punishment in operant conditioning? (17 1/3)
6. (a) Draw the Atkinson-Shiffrin's 3-stage model of memory. (6)
(b) How does long-term memory organize information? (17 1/3)
7. (a) Write the formula of calculating IQ score with an example. (6)
(b) Discuss the different types of intelligence. (17 1/3)
8. (a) What is personality? (6)
(b) Describe the structure of personality in terms of Freud's Psychoanalytic theory. (17 1/3)

Checked

T. D.

L-2/T-2/ARCH

Date : 01/01/2013

BANGLADESH UNIVERSITY OF ENGINEERING AND TECHNOLOGY, DHAKA

L-2/T-2 B. Arch. Examinations 2010-2011

Sub : **CE 267 (CE 225)** (Structure II : Basic Mechanics of Solids)

Full Marks: 140

Time : 3 Hours

USE SEPARATE SCRIPTS FOR EACH SECTION

The figures in the margin indicate full marks.

SECTION - A

There are **SEVEN** questions in this section. Answer any **FIVE**.

1. Draw axial force, shear force and bending moment diagram for the beam shown in Fig. 1. (14)
2. Draw axial force, shear force and bending moment diagram of beam AB shown in Fig. 2. (14)
3. Draw shear force and bending moment diagram of beam shown in Fig. 3. (14)
4. Draw shear force and bending moment diagram of the beam shown in Fig. 4. (14)
5. A $\frac{3}{4}$ inch thick bracket plate is fastened to a 1 inch thick main plate with $\frac{1}{2}$ inch diameter bolt as shown in Fig. 5. Calculate the maximum shear stress on bolt. (14)
6. Design the welded connection required to transmit 120 kip force between an angle $L 5 \times 3 \frac{1}{2} \times \frac{3}{8}$ and $\frac{3}{4}$ inch gusset plate as shown in Fig. 6. Welds are to be deposited manually using E70XX electrodes. Use AISC/ASD method and table-1. (14)
7. A eccentrically loaded welded connection is shown in Fig. 7. If fillet weld size is $\frac{1}{4}$ in, determine the maximum allowable force P for this connection. (14)

SECTION - B

There are **SEVEN** questions in this section. Answer any **FIVE**.

8. (a) Draw the stress-strain diagram for mild steel and identify the yield points, ultimate point and breaking point. (8)
- (b) Differentiate between ductile and brittle material. Give two examples of each type of material. (6)

Contd P/2

CE 267 (CE 225)

9. (a) A glued lap splice is to be made in a 10×20 mm rectangular member at $\alpha = 20^\circ$, as shown in Fig. 8. Assuming that the shear strength of the glued joint controls the design, what axial force 'P' can be applied to the member? Given: the shear strength of the glued joint is 10 MPa. (8)
- (b) A cylindrical steel pressure vessel 400 mm in diameter with a wall thickness of 20 mm is subjected to an internal pressure of 4.5 MN/m^2 . Calculate the tangential and longitudinal stresses in the steel. (6)
10. For the structure shown in Fig. 9, calculate the size of the bolt and area of the bearing plates required if the allowable stresses are 18,000 psi in tension and 500 psi in bearing. Neglect the weight of the beams. (14)
11. Two high-strength steel rods of different diameters are attached at A and C and support a mass M at B, as shown in Fig. 10, What mass M can be supported? The ultimate strength of the rods is 800 MPa, and the factor of safety is to be 2. Rod AB has $A = 250 \text{ mm}^2$; rod BC has $A = 480 \text{ mm}^2$. (14)
12. A 40 kN axial load is applied to a short wooden post as shown in Fig. 11, that is supported by a concrete footing resting on undisturbed soil (Fig. 11). Determine (a) the maximum bearing stress on concrete footing, (b) the size of the footing for which the average stress in soil is 0.2 MPa. (14)
13. A piece of $50 \times 250 \times 10$ mm steel plate is subjected to uniformly distributed stresses along its edges as shown in Fig. 12. (14)
- (a) If $P_x = 100 \text{ kN}$ and $P_y = 200 \text{ kN}$ then determine the change in thickness of plate.
- (b) Determine the P_x alone which will cause the same change in thickness as in (a)
- Given: $E = 200 \text{ GPa}$ and $\nu = 0.25$.
14. Determine the deformation of the steel rod shown in Fig. 13, under the given loads. (14)
- (Given: $E = 29 \times 10^6 \text{ psi}$). Also, calculate the maximum stress in the rod.
-

L-2/T-2/ARCH

Date : 01/01/2013

BANGLADESH UNIVERSITY OF ENGINEERING AND TECHNOLOGY, DHAKA

L-2/T-2 B. Arch. Examinations 2010-2011

Sub : **CE 267 (CE 225)** (Structure II : Basic Mechanics of Solids)

Full Marks: 140

Time : 3 Hours

USE SEPARATE SCRIPTS FOR EACH SECTION

The figures in the margin indicate full marks.

SECTION - AThere are **SEVEN** questions in this section. Answer any **FIVE**.

1. Draw axial force, shear force and bending moment diagram for the beam shown in Fig. 1. (14)
2. Draw axial force, shear force and bending moment diagram of beam AB shown in Fig. 2. (14)
3. Draw shear force and bending moment diagram of beam shown in Fig. 3. (14)
4. Draw shear force and bending moment diagram of the beam shown in Fig. 4. (14)
5. A $\frac{3}{4}$ inch thick bracket plate is fastened to a 1 inch thick main plate with $\frac{1}{2}$ inch diameter bolt as shown in Fig. 5. Calculate the maximum shear stress on bolt. (14)
6. Design the welded connection required to transmit 120 kip force between an angle $L5 \times 3\frac{1}{2} \times \frac{3}{8}$ and $\frac{3}{4}$ inch gusset plate as shown in Fig. 6. Welds are to be deposited manually using E70XX electrodes. Use AISC/ASD method and table-1. (14)
7. A eccentrically loaded welded connection is shown in Fig. 7. If fillet weld size is $\frac{1}{4}$ in, determine the maximum allowable force P for this connection. (14)

SECTION - BThere are **SEVEN** questions in this section. Answer any **FIVE**.

8. (a) Draw the stress-strain diagram for mild steel and identify the yield points, ultimate point and breaking point. (8)
- (b) Differentiate between ductile and brittle material. Give two examples of each type of material. (6)

Contd P/2

CE 267 (CE 225)

9. (a) A glued lap splice is to be made in a 10×20 mm rectangular member at $\alpha = 20^\circ$, as shown in Fig. 8. Assuming that the shear strength of the glued joint controls the design, what axial force 'P' can be applied to the member? Given: the shear strength of the glued joint is 10 MPa. (8)
- (b) A cylindrical steel pressure vessel 400 mm in diameter with a wall thickness of 20 mm is subjected to an internal pressure of 4.5 MN/m^2 . Calculate the tangential and longitudinal stresses in the steel. (6)
10. For the structure shown in Fig. 9, calculate the size of the bolt and area of the bearing plates required if the allowable stresses are 18,000 psi in tension and 500 psi in bearing. Neglect the weight of the beams. (14)
11. Two high-strength steel rods of different diameters are attached at A and C and support a mass M at B, as shown in Fig. 10. What mass M can be supported? The ultimate strength of the rods is 800 MPa, and the factor of safety is to be 2. Rod AB has $A = 250 \text{ mm}^2$; rod BC has $A = 480 \text{ mm}^2$. (14)
12. A 40 kN axial load is applied to a short wooden post as shown in Fig. 11, that is supported by a concrete footing resting on undisturbed soil (Fig. 11). Determine (a) the maximum bearing stress on concrete footing, (b) the size of the footing for which the average stress in soil is 0.2 MPa. (14)
13. A piece of $50 \times 250 \times 10$ mm steel plate is subjected to uniformly distributed stresses along its edges as shown in Fig. 12. (14)
- (a) If $P_x = 100 \text{ kN}$ and $P_y = 200 \text{ kN}$ then determine the change in thickness of plate.
- (b) Determine the P_x alone which will cause the same change in thickness as in (a)
- Given: $E = 200 \text{ GPa}$ and $\gamma = 0.25$.
14. Determine the deformation of the steel rod shown in Fig. 13, under the given loads. (Given: $E = 29 \times 10^6 \text{ psi}$). Also, calculate the maximum stress in the rod. (14)
-

Table 1: Minimum size of fillet weld

Minimum fillet weld size (inch)	Maximum thickness of part (inch)
1/8	To 1/4 inclusive
3/16	Over 1/4 to 1/2
1/4	Over 1/2 to 3/4
5/16	Over 3/4 to 1 1/2
3/8	Over 1 1/2 to 2 1/4
1/2	Over 2 1/4 to 6
5/8	Over 6

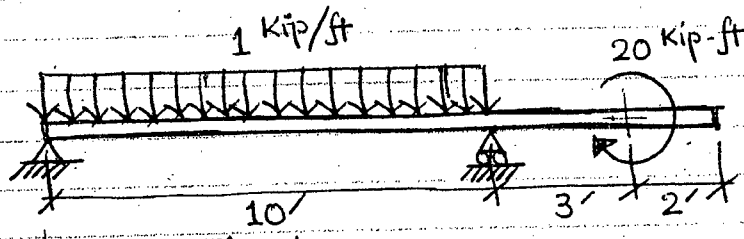

Fig. 1.

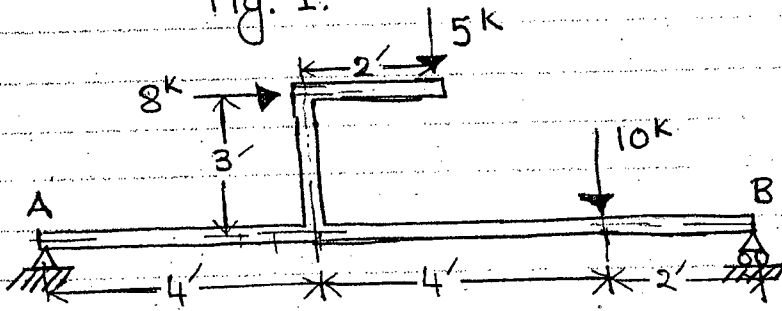

Fig. 2.

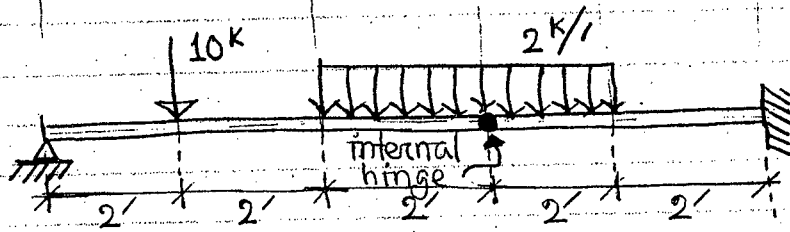

Fig. 3.

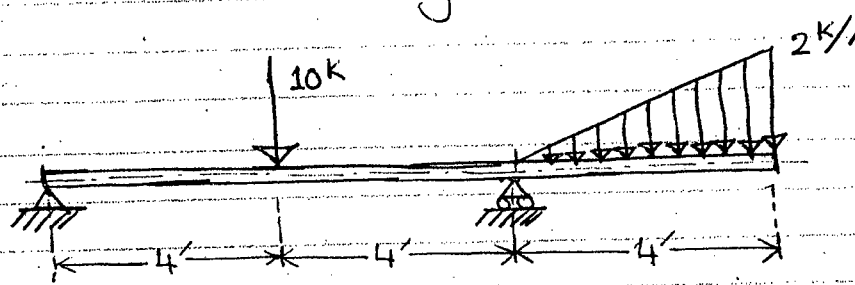

Fig. 4.

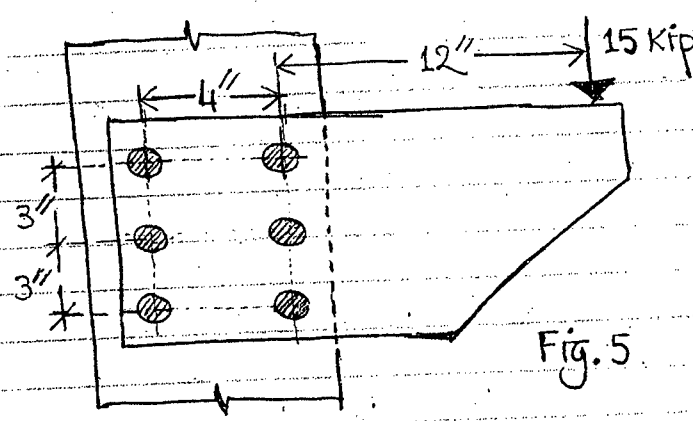
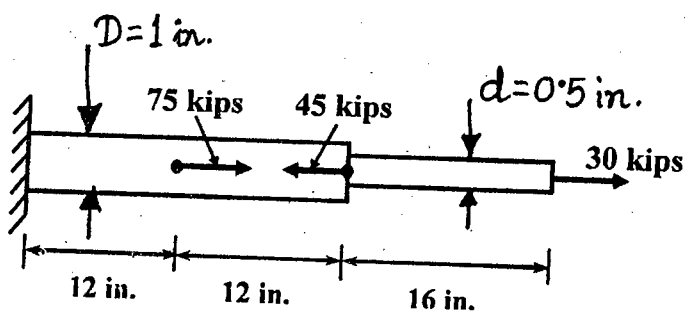
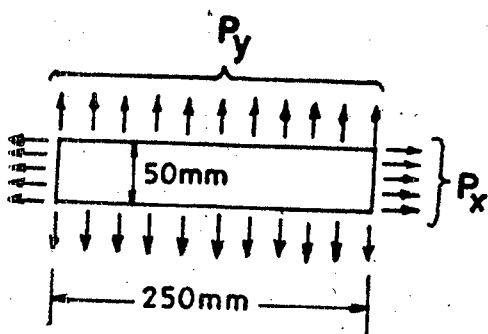
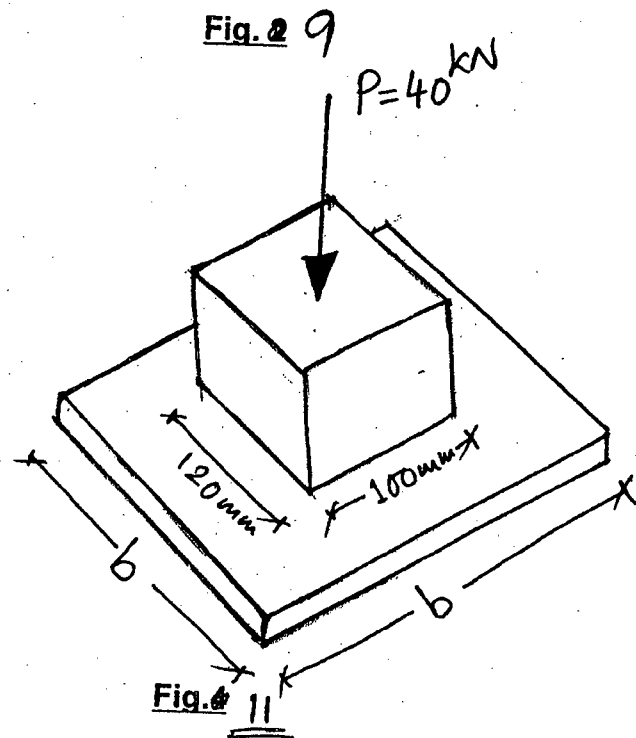
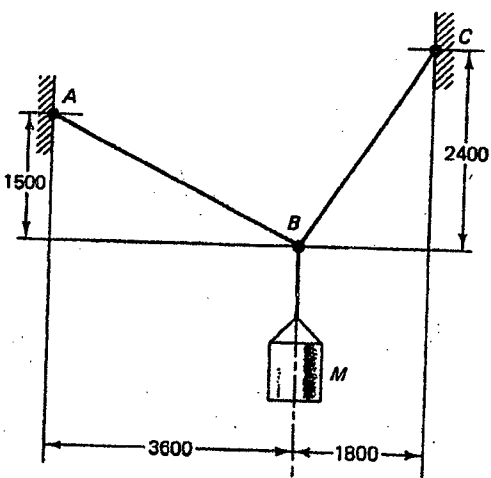
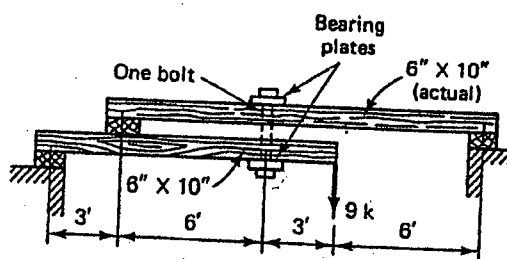
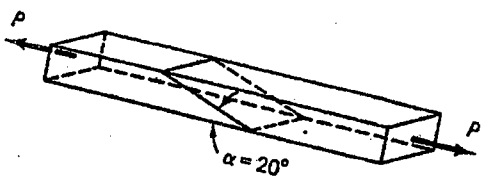
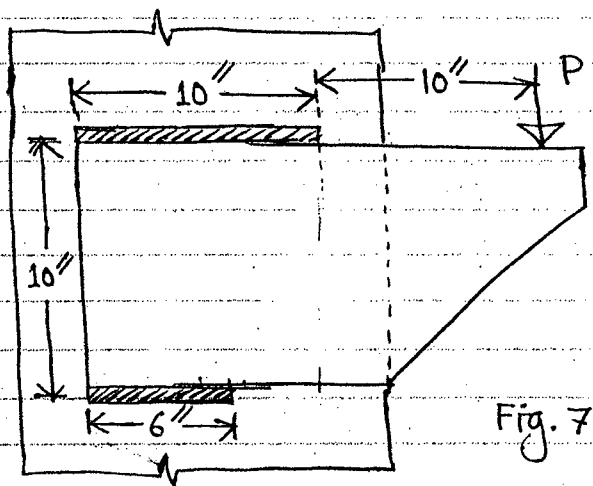
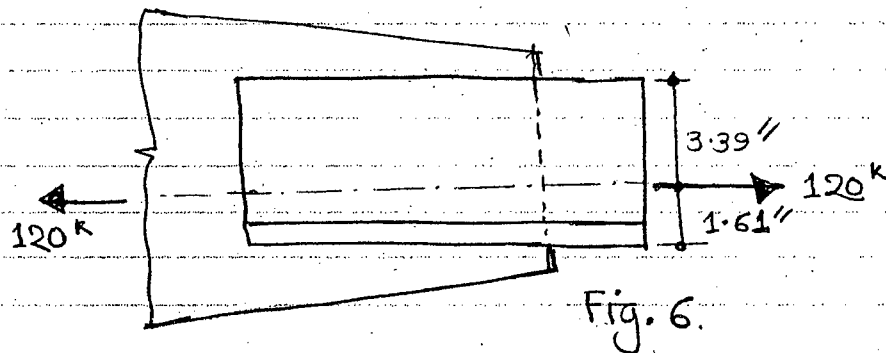

Fig. 5.



Sudin / 26.12.12

L-2/T-2/ARCH

Date : 26/12/2012

BANGLADESH UNIVERSITY OF ENGINEERING AND TECHNOLOGY, DHAKA

L-2/T-2 B. Arch. Examinations 2010-2011

Sub : **CE 271 (CE 231)** (Building Services: Plumbing)

Full Marks: 140

Time : 3 Hours

USE SEPARATE SCRIPTS FOR EACH SECTION

The figures in the margin indicate full marks.

SECTION - A

There are **FOUR** questions in this section. Answer any **THREE**.

1. (a) What is plumbing system? State its objectives. (4)
(b) Differentiate between fixture unit in case of water supply and fixture unit in case of building drainage. (4)
(c) What are the demerits of high water pressure in water supply system of a building? (4)
(d) What is house water service? Draw a neat sketch of it. (7 1/3)
(e) List the uses of valves in plumbing system. (4)
2. (a) How will you ensure "no risk" in the contamination of water supply in a building? (5)
(b) What are the underlying principles of design of water supply piping of a building? (5)
(c) What are the design considerations regarding water supply for tall buildings? (4)
(d) Determine the zoning of a tall building for water supply from the following data: (9 1/3)
30-story building, 10 ft floor to floor.
50 psi at public main.
4 psi loss in water meter.
7 psi loss in piping and fittings of upfeed zone.
Flush-valve fixtures except on 29th and 30th floors where flush-tank fixtures are used.
7 psi highest minimum fixture pressure for flush-tank fixtures.
12 psi highest minimum fixture pressure for flush-valve fixtures.
Maximum pressure at any fixture is not to exceed 50 psi.
Assume reasonable value for any missing data, if required.
3. (a) How will you evaluate fitting and valve friction in water supply piping design? (4)
(b) What are the special considerations for design of riser pipe of downfeed zone? (4)
(c) What is a fixture trap? What do you understand by strength of a trap? How is it determined? (6)
(d) Why flush-tank fixtures are used instead of flush-valve fixtures in top most floors of a tall building? (4)
(e) The available pressure in the riser pipe of a downfeed zone at a certain floor level is 7 psi. Calculate the permissible pressure loss in the riser pipe per 100 ft to supply water to a floor 18 ft below where the highest minimum fixture pressure is 12 psi. Assume reasonable value of missing data, if required. (5 1/3)

Contd P/2

CE 271 (CE 231)

4. (a) What are soil, waste, and vent stacks? Differentiate between self siphonage and induced siphonage of a building drainage system. (7)
- (b) Describe the principal plumbing system of drainage. Which system do you prefer and why? Explain. (9 1/3)
- (c) State the general requirements about installation of drainage pipes in a building. (7)

SECTION – B

There are **FOUR** questions in this Section. Answer any **THREE**.

Assume any reasonable value, if needed.

5. (a) Sketch the essential elements of water supply system. What should be the design period of the system? Explain. (6 1/3)
- (b) List the factors affecting per capita water consumption. What are the water requirements for various purposes in the rural areas of Bangladesh? (7)
- (c) Name the methods of population projection. The population of a community was 15000 in year 2000 and 19000 in year 2010. What will be the population in 2025 and 2035? Apply the most widely used method for calculation. (10)
6. (a) What is hydrologic cycle? Draw a neat sketch of it. (5)
- (b) Can rainwater be a potential source of water supply in Bangladesh? Discuss briefly. (6)
- (c) Design a septic tank for a family of 8 members with a desludging interval of four years. The average wastewater flow is 16 liters per person per day. Assume design temperature to be 25°C. Determine suitable overall dimensions of the septic tank. Assume any reasonable value if necessary. (12 1/3)
7. (a) Define self cleansing velocity and non-scouring velocity of wastewater flow through sewerage system. (4)
- (b) What are the technical advantages of small bore sewerage system over conventional sewerage system? Discuss the applicability of small bore sewerage system in Bangladesh. (4+4=8)
- (c) Design a pour flush latrine for alternating twin pit system, serving a family of 6 members. Consider total wastewater flow per day to be 75 liters. Assume long term infiltration rate of the surrounding soil is 25 litre/m²-day. (7 1/3)
- (d) Define total sanitation. Draw a diagram showing the relationship of sanitation and hygiene with improvement in health condition. (4)
8. (a) Draw a neat sketch showing how groundwater pollution from pit latrine infiltration can be prevented. (4)
- (b) What are the types of conventional sewerage system? Discuss advantages and disadvantages of each type. (8)
- (c) Make comparison of VIP latrine and ROEC as hygienic sanitation options for rural Bangladesh. (6 1/3)
- (d) Write short notes on- (5)
- (i) on-site sanitation system and
- (ii) confined sanitation system.

L-2/T-2/ARCH

Date : 18/12/2012

BANGLADESH UNIVERSITY OF ENGINEERING AND TECHNOLOGY, DHAKA

L-2/T-2 B. Arch. Examinations 2010-2011

Sub : **ARCH 253** (Design Theory - II)

Full Marks: 140

Time : 3 Hours

USE SEPARATE SCRIPTS FOR EACH SECTION

The figures in the margin indicate full marks.

SECTION - A

There are **FOUR** questions in this Section.

Answer Q. No. 1 (One) and any **TWO** from the rest.

1. Write short notes on ANY TWO (02). (2×15=30)
 - (a) Surface Articulation
 - (b) Form Articulation
 - (c) Platonic Solids
2. Describe how 'Single Vertical Plane' and 'U-Shaped Plane' define spaces. (20)
3. What are the types of Additive form? Describe them with sketches. (20)
4. Explain with sketches the reasons for Formal Collision of Geometry. (20)

SECTION - B

There are **FOUR** questions in this Section.

Answer Q. No. 5 (Five) and any **TWO** from the rest.

5. Write short notes on any two (02) (15×2=30)
 - (a) Space within space
 - (b) Structural proportion
 - (c) Scale
 6. (a) What are the different types of 'configuration of the path'? Describe them with sketches. (20)
(b) What are the relationships that exist between path and its adjacent spaces? Discuss them.
 7. Describe 'The Golden Section' and 'The Orders' as theories of proportion. (20)
 8. Describe Centralized and Linear Spatial organization with sketches. (20)
-

~~P/1/13~~

16.01.13

L-2
L-3/T-2/ARCH

Date : 20/11/2012

BANGLADESH UNIVERSITY OF ENGINEERING AND TECHNOLOGY, DHAKA

L-2 L-3/T-2 B. Arch. Examinations 2010-2011

Sub : **ARCH 243** (Art and Architecture III)

Full Marks : 140

Time : 3 Hours

The figures in the margin indicate full marks.

USE SEPARATE SCRIPTS FOR EACH SECTION

SECTION - A

There are **FIVE** questions in this Section. Answer Q. No. 5 and any **THREE** from the rest.

1. (a) What advances were made in art and architecture during the rules of ^{Sungas} Sungas and Andhras? (4)
- (b) Discuss the architectural developments performed after the reconstruction of Sanchi stupa in plan elevation and section. Explain how the issues of scale and proportion were addressed after the extension. (13)
2. (a) What are the three principal architectural elements of a Chaitya hall? (3)
- (b) Which one of the Hinayana type chaitya hall reached its culmination? Describe with plans and necessary sketches. (14)
3. (a) Describe the shrine of Budh Gaya. (9)
- (b) Explain why it gives a poor idea of its architectural character after it has been restored unintelligently. Use necessary sketches. (8)
4. (a) Define the term 'Gumpha'. Why 'Bagh gumpha' is observed as a forceful production of a somewhat morbid imagination' - by the critics. (5)
- (b) Describe how the layout plan of Nalanda University was evolved from the earlier Buddhist monasteries. (12)
5. Write short notes on (any three) of the following (3×6 1/3 =19)
- (a) 'Vastu-purusha-mandala'
- (b) Fortification of Vedic cities
- (c) Pataliputra-city of Maurya King
- (d) Contributions of 'Asokan school of Art and Architecture'

ARCH 243

SECTION - B

There are **FIVE** questions in this Section. Answer Q. No. 10 and any **THREE** from the rest.

6. (a) Mention the two cities that flourished in art and architecture during the pallavas. (6)
(b) Describe the temple of Vaikuntha Perumal with plan and 3-dimensional features. (11)
7. (a) What are the identifying characteristics of Gupta temple? (5)
(b) Compare the architectural aspects of the Vimana of Tanjore temple and Gangaikondacholapuram with dimensions and necessary sketches. (12)
8. (a) Mention the names of 5 important temples of Madura. (5)
(b) Draw the layout plan showing the two main shrines and other surrounding element of the Madura complex. (12)
9. (a) How the temple of Orissa can be resolved into three groups according to their date and style. (5)
(b) Outline the principal components of the sun temple at Konarak. Show the evidences to justify why it appears to be 'never completed'. (12)
10. Describe and distinguish between the floor plans, sections and principal architectural components which forms the style of Khajurahs and Orissan temples. Use sketches. (19)
-