

**SECTION – A**

There are **FOUR** questions in this section. Answer any **THREE**.

1. (a) A package is projected 10 m up a  $15^\circ$  incline so that it just reaches the top of the incline with zero velocity as shown in Fig. 1(a). Knowing that the coefficient of kinetic friction between the package and the incline is 0.12, determine (i) the initial velocity of the package at *A*, (ii) the velocity of the package as it returns to its original position. (17)
- (b) A 500-g collar can slide without friction on the curved rod *BC* in a vertical plane as shown in Fig. 1(b). Knowing that the undeformed length of the spring is 80 mm and that  $k = 400$  kN/m, determine (i) the velocity that the collar should be given at *A* to reach *B* with zero velocity, (ii) the velocity of the collar when it eventually reaches *C*. (18)
2. (a) A 60-g model rocket is fired vertically as shown in Fig. 2(a). The engine applies a thrust *P* which varies in magnitude as shown. Neglecting air resistance and the change in mass of the rocket, determine (i) the maximum speed of the rocket as it goes up, (ii) the time for the rocket to reach its maximum elevation. (17)
- (b) Two identical hockey pucks are moving on a hockey rink at the same speed of 3 m/s and in perpendicular directions when they strike each other as shown in Fig. 2(b). Assuming a coefficient of restitution  $e = 0.9$ , determine the magnitude and direction of the velocity of each puck after impact. (18)
3. (a) A 20-kg cabinet is mounted on casters that allow it to move on the floor as shown in Fig. 3(a). The coefficient of kinetic friction between the casters and the floor is  $\mu_k = 0.25$ . If a 100-N force is applied as shown, determine (i) the acceleration of the cabinet, (ii) the range of values of *h* for which the cabinet will not tip. (17)
- (b) Two 4-kg uniform bars are connected to form the linkage as shown in Fig. 3(b). Neglecting the effect of friction, determine the reaction at *D* immediately after the linkage is released from rest in the position shown. (18)
4. (a) At the instant shown in Fig. 4(a), the slider block *B* is moving with a constant acceleration, and its speed is 150 mm/s. Knowing that after the slider block *A* has moved 240 mm to the right its velocity is 60 mm/s, determine (i) the accelerations of *A* and *B*, (ii) the acceleration of portion *D* of the cable, (iii) the velocity and the change in position of slider block *B* after 4 s. (17)
- (b) A slender 4-kg rod can rotate in a vertical plane about a pivot at *B*. A spring of constant  $k = 400$  N/m and of unstretched length 150 mm is attached to the rod as shown in Fig. 4(b). Knowing that the rod is released from rest in the position shown, determine its angular velocity after it has rotated through  $90^\circ$ . Solve the problem using the principle of conservation of energy. (18)

**ME 249**

**SECTION – B**

There are **FOUR** questions in this section. Answer any **THREE**.

5. (a) The two blocks as shown in Fig. for Q. 5(a) are originally at rest. Neglecting the masses of the pulleys and the effect of friction in the pulleys and between block A and the horizontal surface, determine (i) the acceleration of each block and (ii) the tension in the cable. (17)

- (b) The horizontal rod  $OA$  as shown in Fig. for Q. 5(b) rotates about a vertical shaft according to the relation  $\dot{\theta} = 10t$ , where  $\dot{\theta}$  and  $t$  are expressed in rad/s and seconds, respectively. A 250-g collar  $B$  is held by a cord with a breaking strength of 18 N. Neglecting friction, determine, immediately after the cord breaks, the relative acceleration of the collar with respect to the rod. (18)

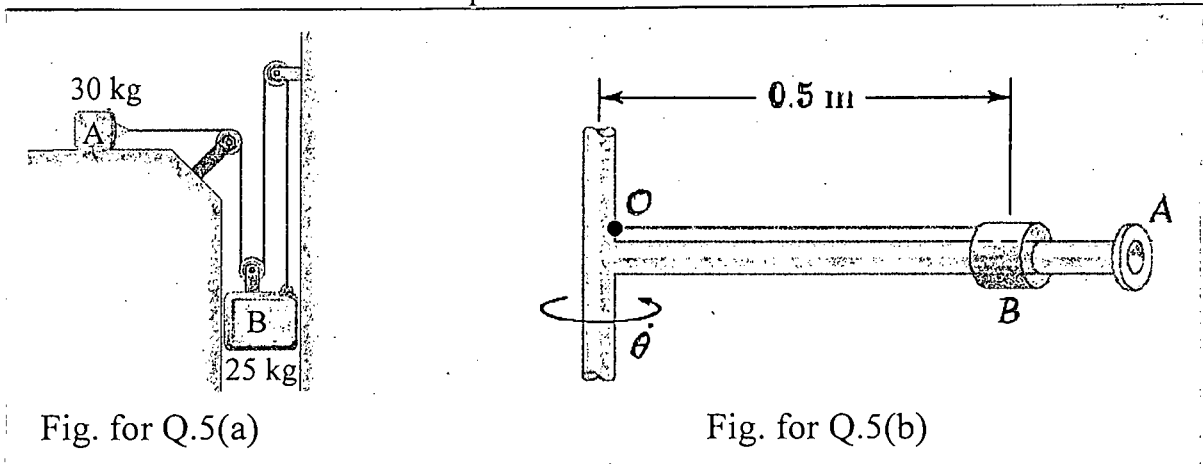

6. (a) A 90-kg man and a 60-kg woman stand at the same end of a 150-kg boat, ready to dive, each with a 5 m/s velocity relative to the boat. Determine the velocity of the boat after they have both dived, if the woman dives first. (17)

- (b) In a game of pool as shown in Fig. for Q. 6, ball  $A$  is moving with a velocity  $V_0$  of magnitude  $V_0 = 5$  m/s when it strikes balls  $B$  and  $C$ , which are at rest and aligned as shown. Knowing that after the collision, the three balls move in the directions indicated and assuming frictionless surfaces and perfectly elastic impact (i.e., conservation of energy), determine the magnitudes of the velocities  $V_A$ ,  $V_B$ , and  $V_C$ . (18)

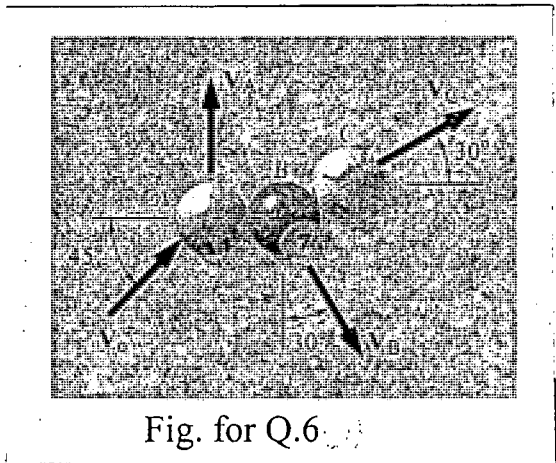

**ME 249**

7. (a) The bent rod  $ABCDE$  as shown in Fig. for Q. 7(a) rotates about a line joining points  $A$  and  $E$  with a constant angular velocity of  $9 \text{ rad/s}$ . Knowing that the rotation is clockwise as viewed from  $E$ , determine the velocity and acceleration of corner  $C$ . (17)

(b) At the instant shown in Fig. for Q. 7(b), the angular velocity of crank  $AB$  is  $2.7 \text{ rad/s}$  clockwise. Using the method of instantaneous center of rotation, determine (i) the angular velocity of link  $BD$ , (ii) velocity of collar  $D$ . (18)

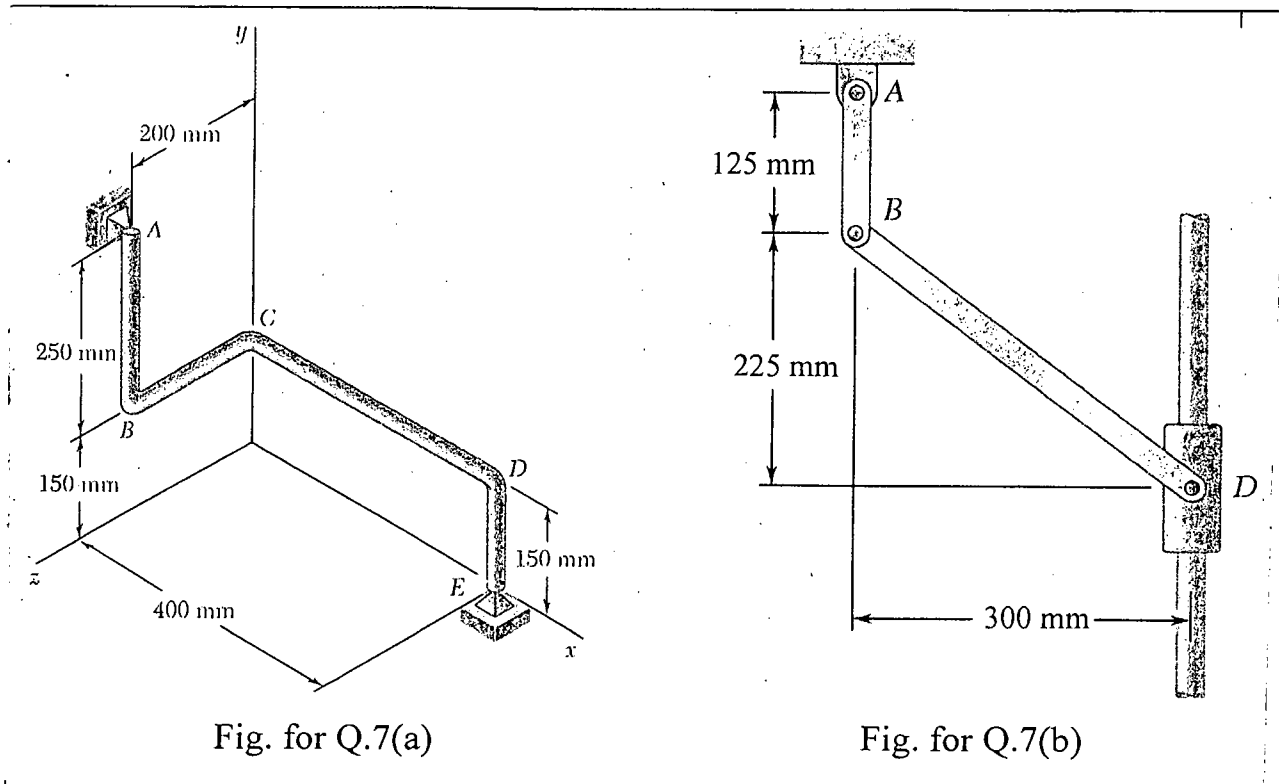

Fig. for Q.7(a)

Fig. for Q.7(b)

8. In the mechanism as shown in Fig. for Q. 8,  $OB$  rotates at uniform rate of  $20 \text{ rad/s}$ . Determine the velocity and acceleration of  $D$  using graphical method. Note  $OA = 150 \text{ mm}$ ,  $OB = 75 \text{ mm}$ ,  $AC = 300 \text{ mm}$ ,  $CD = 250 \text{ mm}$ . (35)

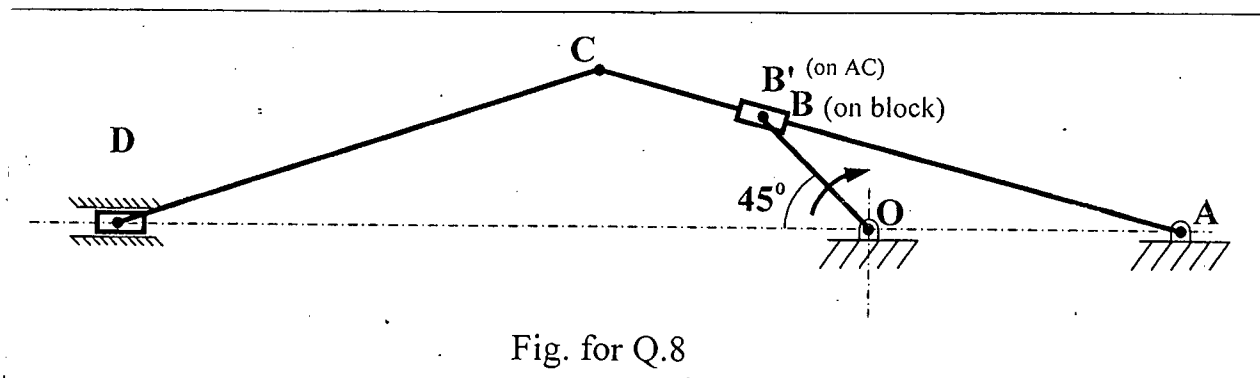

Fig. for Q.8

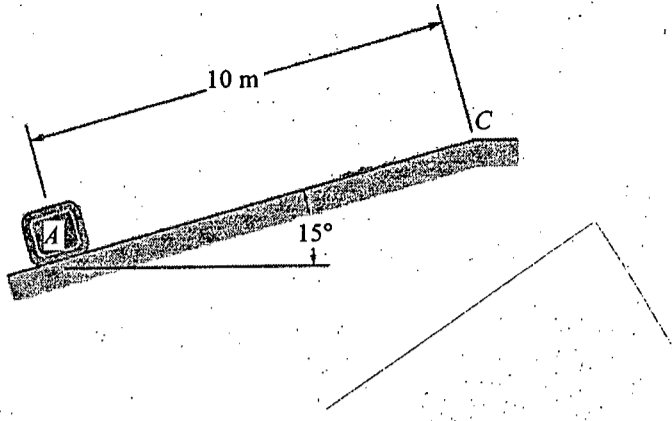

Fig. 1(a)

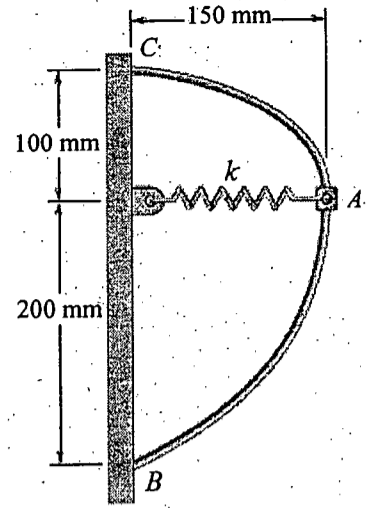

Fig. 1(b)

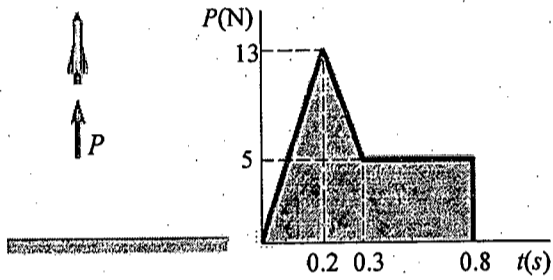

Fig. 2(a)

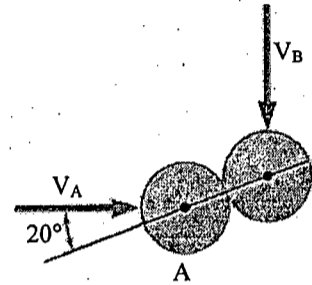

Fig. 2(b)

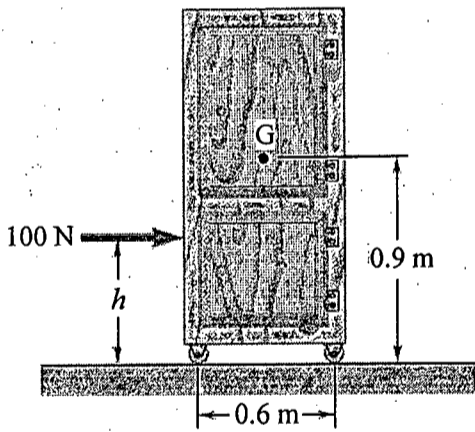

Fig. 3(a)

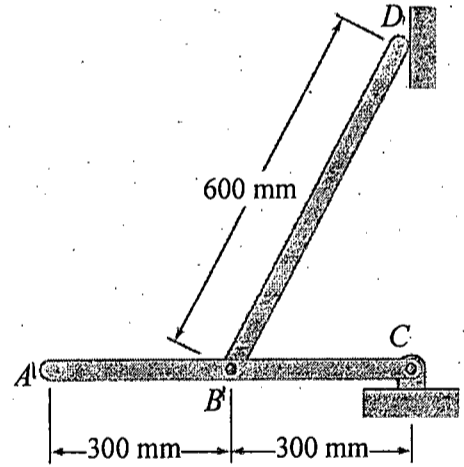

Fig. 3(b)

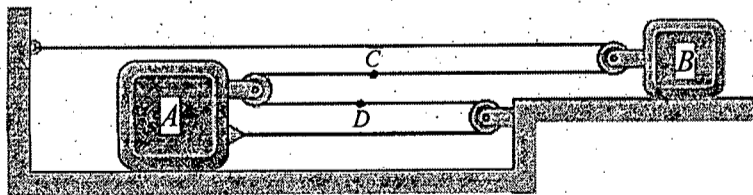

Fig. 4(a)

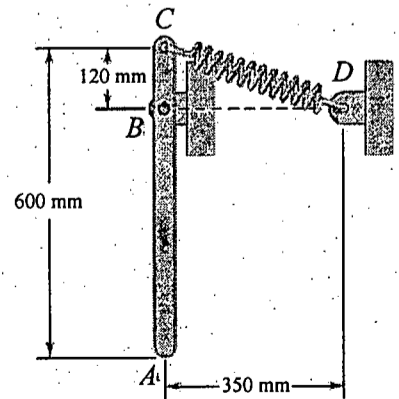
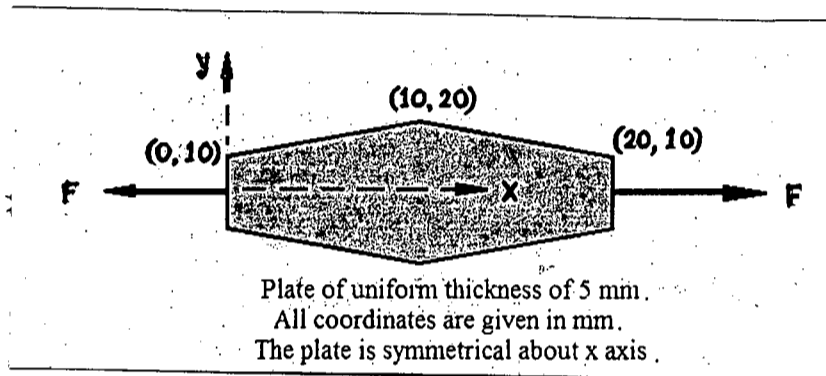

Fig. 4(b)

**SECTION – A**

There are **FOUR** questions in this section. Answer any **THREE**.

1. (a) A metallic machine component (as shown in figure 1(a)) is manufactured from a metal plate of 5 mm thickness. If the component is subjected to a load of  $F = 10$  kN, determine the total elongation of the metallic machine component. (18)



**Fig. for Q. No. 1(a)**

- (b) Two metal rods are connected and placed within two fixed walls with a gap of 1 mm as shown in figure 1(b). If the operating temperature is change from  $20^{\circ}\text{C}$  to  $1020^{\circ}\text{C}$ , find the stresses developed in each rod. The coefficient of thermal expansion for rod-1 and rod-2 are  $10^{-5}$  and  $10^{-4}$  mm/(mm $^{\circ}\text{C}$ ), respectively. Modulus of elasticity for rod-1 is  $E_1 = 200$  GPa and for rod-2, it is  $E_2 = 100$  GPa. (17)

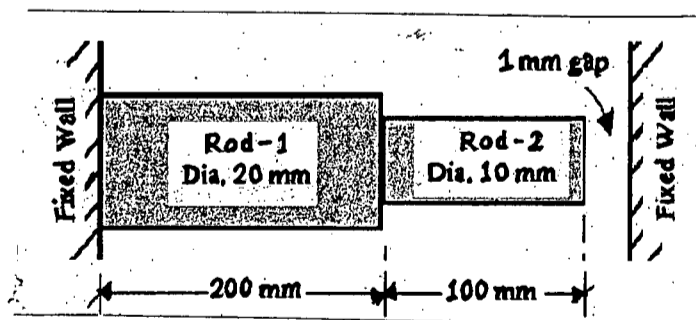
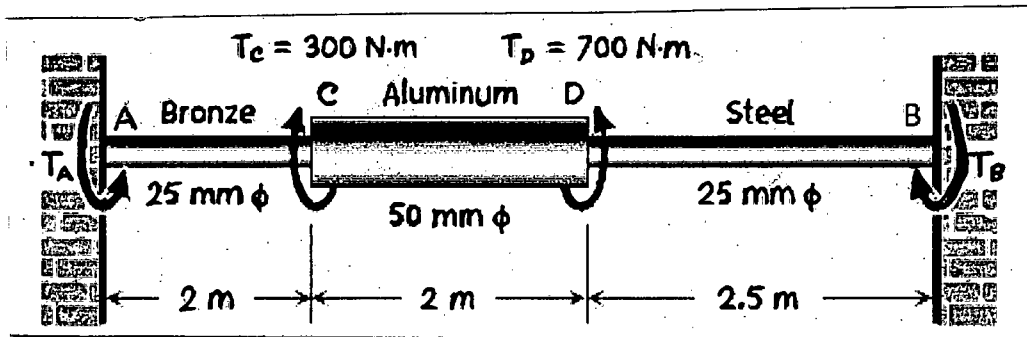

**Fig. for Q. No. 1(b)**

2. (a) A shaft is loaded as shown in figure 2(a). Determine the angular deflection of point C with respect to point D. The modulus of rigidity of bronze, aluminum and steel are 35, 28 and 80 GPa respectively. Also find the maximum torsional stress developed in each segment. (20)

**ME 243**

Contd... Q. No. 2(a)



**Fig. for Q. No. 2(a)**

(b) A thin walled cylinder of inner diameter 200 mm and thickness 10 mm is pressurized by an internal pressure. If the allowable circumferential stress is 600 MPa, find the maximum internal pressure it can withstand. (15)

3. (a) A beam is subjected to a concentrated load of 10 kN, an uniformly distributed load of 3 kN/m and an external moment of 10 kNm as shown in figure 3(a). Draw the shear force and bending moment diagram for the beam. (17)

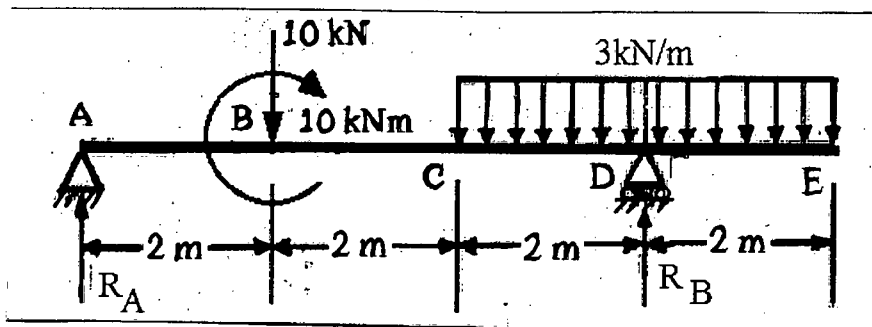

**Fig. for Q. No. 3(a)**

(b) For the beam shown in figure 3(b), find the value of 'h' if the tensile yield strength of the beam material is 400 MPa. Consider factor of safety  $N = 2$  for your calculation. (18)

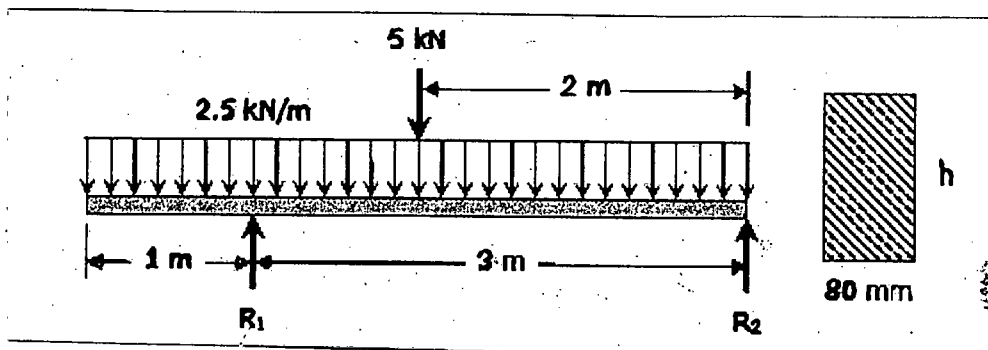

**Fig. for Q. No. 3(b)**

**ME 243**

4. (a) Determine the location and value of maximum deflection of the beam shown in figure 4(a). (17)

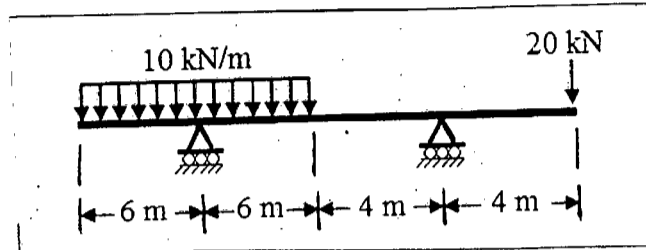

**Fig. for Q. No. 4(a)**

- (b) A cantilever beam of length  $L$  is loaded with two concentrated forces  $P$  and  $2P$  as shown in figure 4(b). Derive the expression for free end deflection of the cantilever beam using area moment method. Ignore self weight of beam. (18)

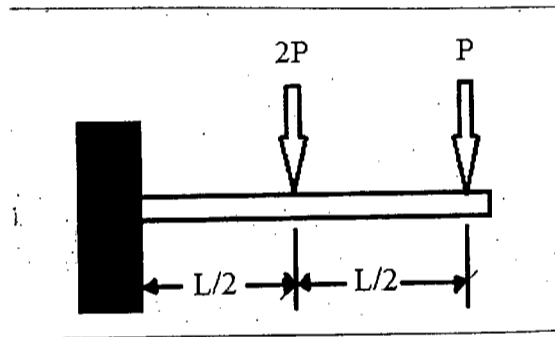

**Fig. for Q. No. 4(b)**

**SECTION - B**

There are **FOUR** questions in this section. Answer any **THREE**.

Assume reasonable value of any missing data.

5. (a) A rigid bar, hinged at one end, is supported by two identical springs as shown in Fig. 5(a). Each spring consists of 20 turns of 10 mm wire having a mean diameter of 150 mm. If the allowable shearing stress in spring is 80 MPa, find the maximum value of force  $F$ . Consider,  $G = 80$  GPa for the spring material. (18)

- (b) A curved cantilever beam is loaded as shown in Fig. 5(b). The material is mild steel with  $S_y = 250$  MPa. Determine the maximum value of force  $P$  that can be applied to this beam. Consider, the beam has a square cross section of  $30 \times 30$  mm. (17)

Contd ..... P/4

**ME 243**

6. (a) A steel column is to support an axial load of 15 kN. The column material has a yield strength of 250 MPa and the Young's modulus,  $E = 200$  GPa. The cross section of the column is circular in shape and the length of the column is 0.4 m. Using AISC specification, find the safe diameter of this column. Use fixed-hinged end condition effect in your calculation. (18)
- (b) The cantilever beam carries a load  $P$ , which is supported by the steel column ( $\sigma_y = 250$  MPa,  $E = 200$  MPa) using the bolted joints as shown in Fig. 6(b). If the cross section of the column is  $100 \times 100$  mm square section, find the allowable value of  $P$  that can be applied. Assume fixed-free end condition. (17)
7. (a) On the surface of a microprocessor package, the stress distribution at a point has been found as shown in Fig. 7(a). Find the principal stresses, maximum shear stress at that point along with their directions. In sketches, show the planes of the principal stresses and maximum shear stress. (17)
- (b) The aluminum shaft ( $\sigma_y = 150$  MPa) is subjected to the combined torsional and axial loading as shown in Fig. 7(b). Using a safety factor of 2, determine the minimum diameter of the shaft for this loading. Assume, yield stress in shear as 50% of the tensile yield stress for this material. (18)
8. (a) A thick walled cylinder having outer diameter 200 mm and inner diameter 120 mm is subjected to an internal pressure of 60 MPa. Determine the maximum shear stress developed in the cylinder. Also, calculate the factor of safety, if the yield strength in shear is 200 MPa. (18)
- (b) A  $45^\circ$  strain rosette is mounted on the surface of an aluminum plate. The following readings are obtained for each gauge:  $\epsilon_a = 400 \times 10^{-6}$ ,  $\epsilon_b = 200 \times 10^{-6}$ , and  $\epsilon_c = -300 \times 10^{-6}$ . Determine the in-plane principal strains at this point. (17)
-



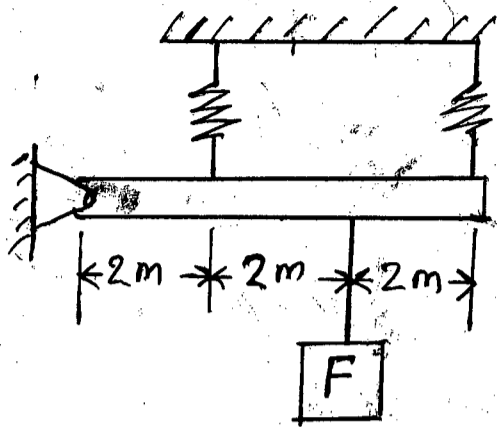

Fig. for Q. No. 5(a)

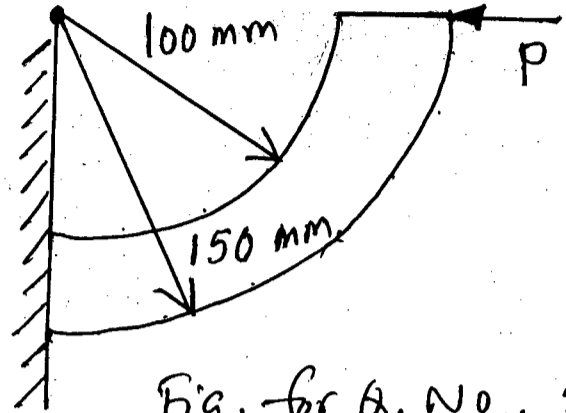

Fig. for Q. No. 5(b)

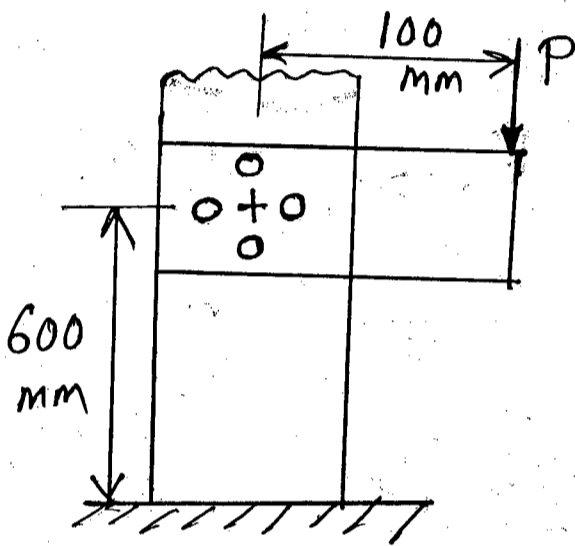

Fig. for Q. No. 6(b)

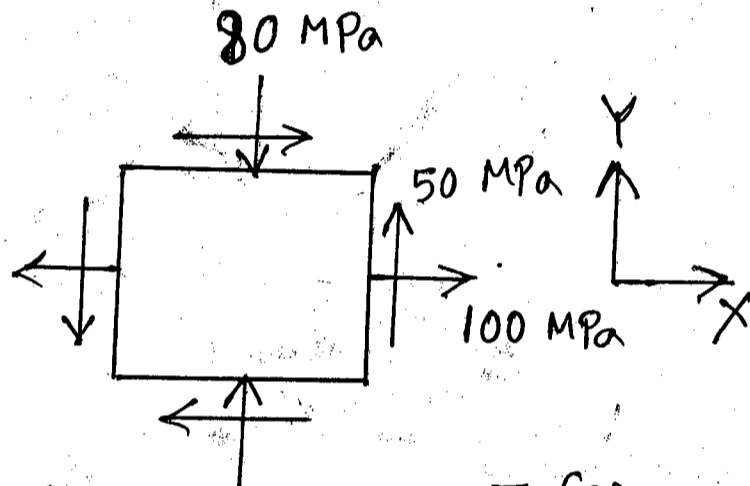

Fig. for Q. No. 7(a)

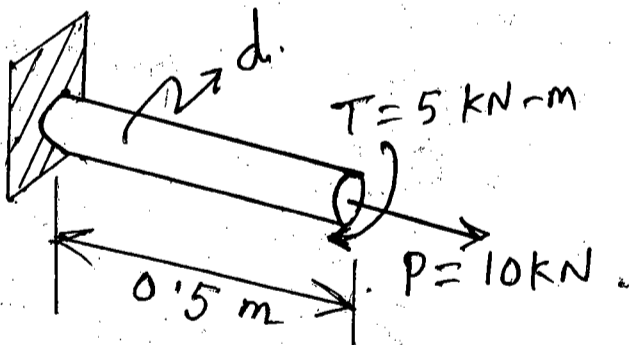

Fig. for Q. No. 7(b)

**SECTION – A**

There are **FOUR** questions in this section. Answer any **THREE**.

1. (a) Consider a second order ordinary differential equation: (20)

$$\frac{d^2u}{dx^2} + k^2u = 0$$

where  $k$  is a parameter. The corresponding boundary conditions are  $u|_{x=0} = u|_{x=1.0} = 0$ .

The above equation can be linearized using central finite difference approximation and the general form of the resultant linear equation at node  $i$  can be written as:

$$u_{i-1} - (2 - h^2k^2)u_i + u_{i+1} = 0$$

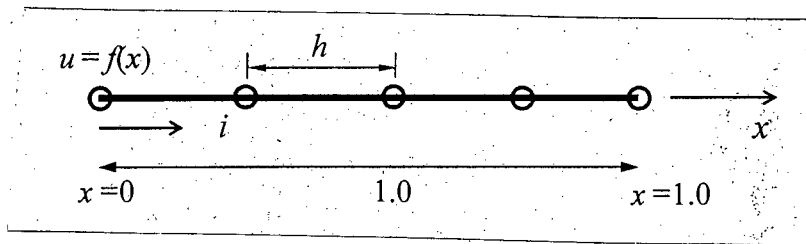

**Fig. for Q. 1(a)**

- (i) Construct the above system in the form of  $[A]\{u\} = \lambda\{u\}$  for the discretization of the 1-D domain as shown in Fig. for Q. 1(a).
  - (ii) Determine the characteristic polynomial for  $k$  in order to obtain the possible nontrivial solutions for the above problem.
  - (iii) Find one of the values of  $k$  from the above polynomial (found in (ii)) using bisection method within the bracket  $[0, 1]$  with  $\epsilon_s < 5\%$ .
  - (iv) Determine the corresponding characteristic vector,  $\{u\}$ .
- (b) Which approximation is better from the following cases of approximation of exact value? (8)

Case #	Exact	Approximation
Case-A	100,000	99,998
Case-B	0.0001567	0.0001566
Case-C	3.14159	3.141

Justify your answer.

- (c) What do you mean by condition number of a function? Estimate the condition number for the function,  $f(x) = \frac{10}{1-x^2}$  at  $x = 0.99$ . (7)

**ME 261**

2. (a) Solve the following non-linear equation using Newton's method accurate upto five significant figures. (15)

$$f(x) = x^2 - e^{-3x^2} - 3$$

Take starting value of  $x_0 = 0.1$ .

- (b) It is known that the Newton's method of root finding converges quadratically. Confirm this statement using error analysis of the above problem given in Q. 2(a). (10)

- (c) Again solve the above equation (Q. 2(a)) but with a starting guess of  $x_0 = 0$ . Is there any abnormality in the progress of iteration? Explain graphically. (10)

3. (a) There are two systems of linear equations (20)

$$[A]\{X\} = \{b_i\} \quad ; \quad i = 1, 2$$

with

$$[A] = \begin{bmatrix} 1 & 2 & -1 & 0 \\ 3 & 4 & 0 & 1 \\ 0 & 2 & 5 & 4 \\ 1 & 2 & 3 & 4 \end{bmatrix} \quad ; \quad \{b_1\} = \begin{bmatrix} 2 \\ 15 \\ 35 \\ 30 \end{bmatrix} \quad ; \quad \{b_2\} = \begin{bmatrix} -3 \\ -3 \\ 0 \\ 3 \end{bmatrix}$$

Solve the above two systems using LU decomposition method.

- (b) Consider the following system (15)

$$\begin{aligned} 16x_1 + 4x_2 + x_3 &= 2 \\ 4x_1 + 2x_2 + x_3 &= 7 \\ 49x_1 + 7x_2 + x_3 &= 30 \end{aligned}$$

Is the system "well-conditioned" or "ill-conditioned"? Justify your comment using matrix  $\infty$ -norm analysis.

4. (a) In solving a particular problem, the following coefficient matrix has been obtained: (15)

$$\begin{bmatrix} 2+0.1\Delta x^2 & -1 & 0 & 0 & 0 & 0 & 0 & 0 \\ -1 & 2+0.1\Delta x^2 & -1 & 0 & 0 & 0 & 0 & 0 \\ 0 & -1 & 2+0.1\Delta x^2 & -1 & 0 & 0 & 0 & 0 \\ \vdots & \vdots & \vdots & \vdots & \vdots & \vdots & \vdots & 0 \\ \vdots & \vdots & \vdots & \vdots & \vdots & \vdots & \vdots & \vdots \\ \vdots & \vdots & \vdots & \vdots & -1 & 2+0.1\Delta x^2 & -1 & \vdots \\ 0 & 0 & 0 & 0 & 0 & -1 & 2+0.1\Delta x^2 & -1 \\ 0 & 0 & 0 & 0 & 0 & 0 & -1 & 2+0.1\Delta x^2 \end{bmatrix}$$

- (i) Mention whether the direct or iterative approach is recommended for solving the above system.
- (ii) If iterative approach is to be used, determine the required condition for the above system to converge.
- (iii) Formulate the general convergence criterion for the solution of a system of equations with iterative approach.

**ME 261**

**Contd... Q. No. 4**

(b) Solve the following linear system of equations by the Gauss-Seidel method. Show at least five iterations: (20)

$$\begin{bmatrix} 3 & -1 & 0 & -1 \\ -1 & 3 & -1 & 0 \\ 0 & -1 & 4 & -1 \\ -1 & 0 & -1 & 4 \end{bmatrix} \begin{Bmatrix} x_1 \\ x_2 \\ x_3 \\ x_4 \end{Bmatrix} = \begin{Bmatrix} -3 \\ 2 \\ 6 \\ 12 \end{Bmatrix}$$

Start with an initial value of  $x_0 = [0, 0, 0, 0]^T$ .

**SECTION-B**

There are **FOUR** questions in this section. Answer any **THREE**.

5. (a) Show that the local truncation error associated with the Trapezoidal rule of integration is  $\frac{-h^3}{12} f''(\xi)$ . How can one obtain the exact result using the Trapezoidal rule? (10)

(b) The total mass of a variable density rod is given by (25)

$$m = \int_0^L \rho(x) A_c(x) dx$$

where  $m$  = mass,  $\rho(x)$  = density,  $A_c(x)$  = cross-sectional area,  $x$  = distance along the rod and  $L$  = the total length of the rod. The following data has been measured for a 10-m length rod. Determine the mass in kilograms using Simpson's rule of integration.

$x, m$	0	2	3	4	6	8	10
$\rho, g/cm^3$	4.00	3.95	3.89	3.80	3.60	3.41	3.30
$A_c, cm^2$	100	103	106	110	120	133	150

6. (a) Derive the finite difference formula of first derivative with an error of  $O(h^4)$  using central finite difference approximation. (10)

(b) The displacement of an instrument subjected to a random vibration test, at different instants of time, is found to be as follows: (25)

Station, i	Time, $t_i$ (s)	Displacement, $y_i$ (inch)
1	0.05	0.144
2	0.10	0.172
3	0.15	0.213
4	0.20	0.296
5	0.25	0.070
6	0.30	0.085
7	0.35	0.525
8	0.40	0.110

Determine the velocity,  $\frac{dy}{dt}$  and acceleration,  $\frac{d^2y}{dt^2}$  at  $t = 0.05, 0.10, 0.15, 0.20, 0.25, 0.30, 0.35$  and  $0.40$  using suitable finite difference formulas.

**ME 261**

7. (a) The data below was obtained from a creep test performed at different temperatures and loads on steel specimen. It is found that (25)

$$\text{Stress, } S = f(T, L) \text{ where } T = \text{temperature and } L = \text{load.}$$

Using the multiple linear regression, find the equation of the line which best fits the data.

Temperature ( $T$ )	0	18	18	27	27	33	33	41	41
Load ( $L$ )	0	10	20	10	20	10	20	10	20
Stress ( $S$ )	0	18	12.8	25.7	20.6	35.0	29.8	45.5	40.3

- (b) Suppose there are  $n$  number of data points to be fitted in a linear curve in the following form— (10)

$$y = a_0 + a_1x$$

Determine the generalized expressions of  $a_0$  and  $a_1$  using least-squares regression.

8. (a) Compare the performance of Euler and Heun's methods to the initial value problem (15)

$$y' = -y + t + 1, \quad 0 \leq t \leq 1, \quad y(0) = 1$$

for any choice of  $h$ . Comment on your findings.

- (b) Blasius (1908) proposed an equation for flow over a flat plate as follows: (20)

$$\frac{d^3 f}{d\eta^3} + \frac{f}{2} \frac{d^2 f}{d\eta^2} = 0$$

where  $f(0) = f'(0) = 0$  and Howarth (1938) found that  $f''(0) = 0.332$ . Find the value of  $f$  and  $f'$  at  $\eta = 5$  with  $h = 1$  using 2<sup>nd</sup> order RK method. Compare your results with the exact value of  $f'(5) = 1.0$ .

-----

**SECTION – A**

There are **FOUR** questions in this section. Answer any **THREE**.

1. (a) What is yield stress? Why do upper and lower yield points appear in stress-strain diagram during tensile testing of steels? (12)
- (b) A paper clip is made of wire 1.20-mm in diameter. If the original material from the wire is made from a rod 15-mm in diameter, calculate the longitudinal and radial engineering and true strains that the wire has undergone. (10)
- (c) A cylindrical specimen of a brass alloy 10.0 mm in diameter and 120.0 mm long is pulled in tension with a force of 11,750 N; the force is subsequently released (13)
  - (i) Compute the final length of the specimen at this time. Use Figure 1 for your computation.
  - (ii) Using Figure 1 again compute the final specimen length when the load is increased to 23,500 N and then released.
  
2. (a) "Hardness of a material can be properly measured using proper quantitative hardness testing method". Explain this statement for the case of low carbon steel and cast iron. (12)
- (b) Wire drawing method is used to produce a copper of 0.2 in diameter from a copper wire of 0.4 in diameter. Using the Figure 2 calculate the drawing force required to deform the initial copper wire and the stress acting on the wire after passing through the die. Comment on the final state of the wire. Will it break or not? (13)
- (c) What are the strengthening changes that occur during anyone of these strengthening processes? (10)
  
3. (a) Determine the minimum allowable thickness for a 3-in.-wide plate made of steel that has a fracture toughness of  $9000 \text{ psi}\sqrt{\text{in}}$ . The plate must withstand a tensile load of 40,000 lb. The minimum allowable thickness of the part will depend on the minimum flaw size that can be determined by the available testing technique. Assume that three nondestructive testing techniques are available. X-ray radiography can detect flaws larger than 0.02 in.; gamma-ray radiography can detect flaws larger than 0.008 in.; and ultrasonic inspection can detect flaws larger than 0.005 in. Assume that the geometry factor  $Y = 1.0$  for all flaws. (15)
- (b) A.K. Company has produced several thousand shafts that have a fatigue strength of 20,000 psi. The shafts are subjected to high bending loads during rotation. The sales engineers report that the first few shafts placed into service failed in a short period of time by fatigue. Suggest and explain three processes by which the remaining shafts can be salvaged by improving their fatigue properties. (10)
- (c) Why and how does creep failure occur? Explain with suitable figures. (10)

**MME 291**

4. (a) Draw the annealed and normalized microstructure of three steel samples containing (i) 0.35% C, (ii) 0.6% C and (iii) 1.2% C. (12)  
(b) Mention the structure and properties of the zones of a nitrided case briefly. Differentiate between carburizing and flame hardening methods. (16)  
(c) Illustrate the influence of chemical composition on the martensite transformation temperatures. (7)

**SECTION-B**

There are **FOUR** questions in this section. Answer any **THREE**.

5. (a) Discuss the basic method of iron making. (6)  
(b) State what happens to the impurity oxides that enter the blast furnace in the correct sequence up to their removal. Do 100% of these oxides get removed? (10+2)  
(c) For an alloy containing 4% Cu calculate the change of the amount of precipitate from 600°C to 500°C (see Figure 3). (10)  
(d) "During non Equilibrium cooling the grain boundary may act as the plane of weakness" — Explain. (7)
6. (a) Describe steel making using the LD process. If LD process is so fast and efficient, why is it not used in our country? (20+3)  
(b) Explain how an induction furnace works. Why is scrap grading important for us? (9+3)
7. (a) A ferrous alloy is required that has good castability, good wear resistance and a high degree of ductility.  
(i) Suggest an alloy and explain how each desired property is present in your alloy. (13)  
(ii) If a little more strength is required instead of ductility, can you think of a way to fulfill the requirement without changing the composition of your chosen alloy? (5)  
(b) Suppose you have ordinary low carbon steel (%C<0.2) and the option of adding Ni, Cr, C, V and Mo as alloying elements. Your target is to make steel blades suitable for surgical instruments. State with clear reasoning(s) which alloying elements you will add and in what amount. (17)
8. (a) What are the significance of the  $A_3$  and  $A_{cm}$  lines in Fe-Fe<sub>3</sub>C diagram? (5)  
(b) With a neat sketch describe the effect of C content on the structure and properties of plain C steel. (15)  
(c) The unfilled space in austenite is much lower than that of ferrite. However the solubility of carbon in austenite is much greater than it is in ferrite-why? (10)  
(d) In a radiograph what will be the difference in appearance of cracks and high density impurities? (5)
-

= 3 =

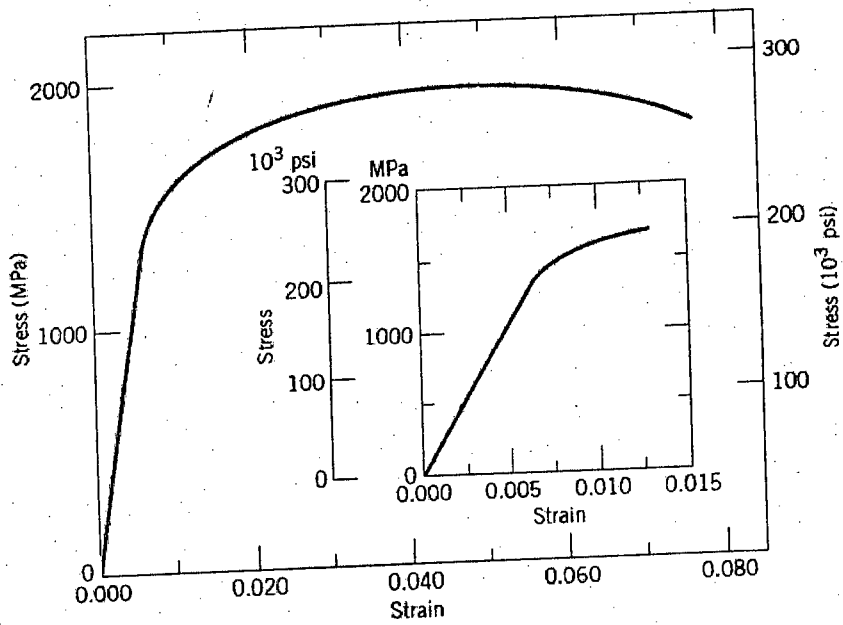

Figure 1: The tensile stress-strain behavior of brass alloy  
for Q 1(c)

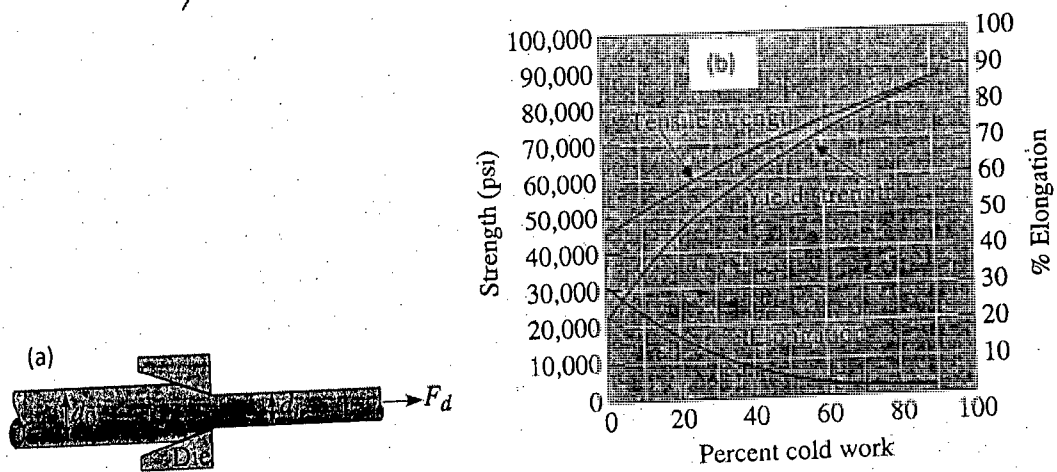

Figure 2: (a) Wire drawing method for copper wire (b) The effect of cold work on the mechanical properties of copper.

for Q 2(b)

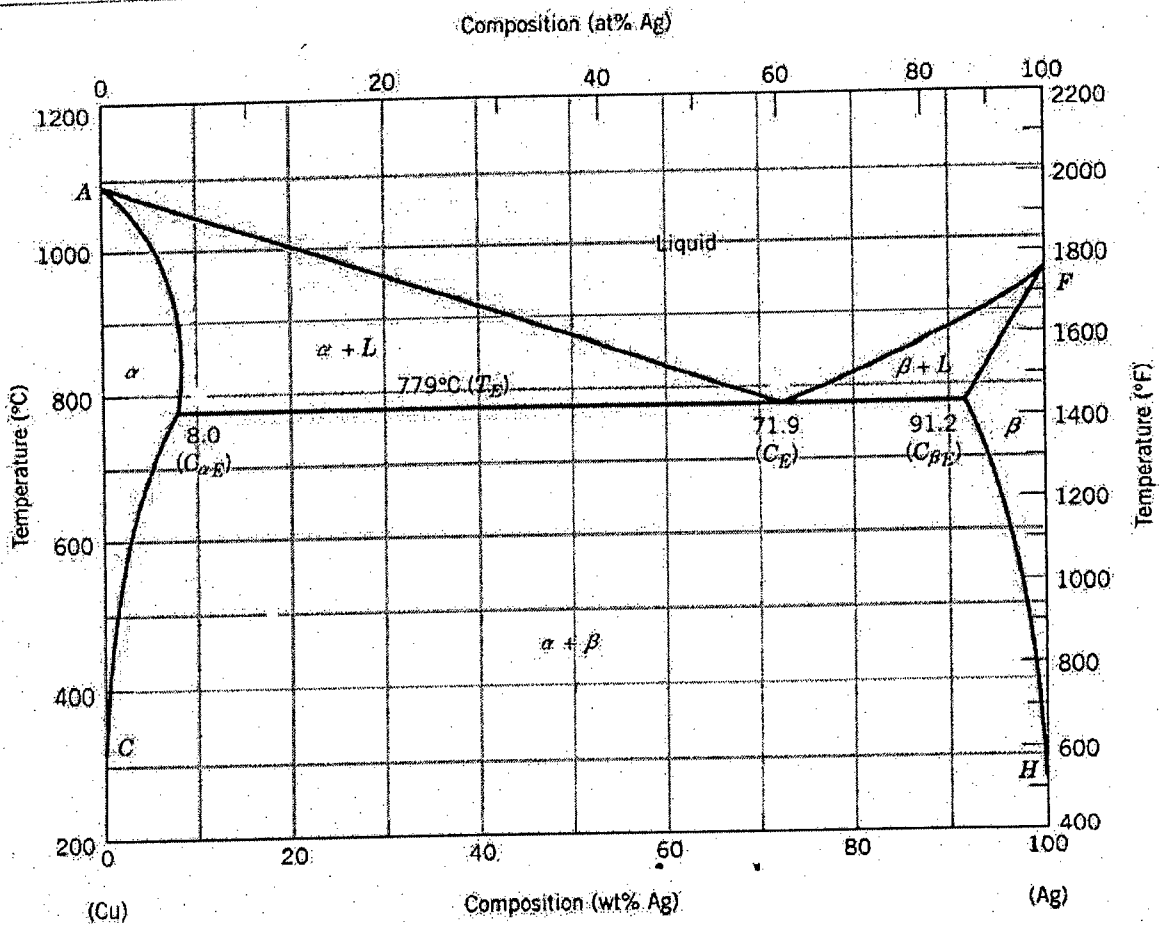

Figure for Q. 5(c)

3