

SECTION – A

There are **NINE** questions in this section. Answer any **SEVEN**.

1. Suppose you are rendering a scene using ray tracing. The position of the eye is at (3, 5, 2). A particular ray is casted through a pixel whose centre is at (12, 24, 16). There is only a sphere in the scene with centre at (20, 40, 30) and radius equal to 10 units. Determine the point on the sphere which will be visible to the eye for this particular ray. If the ray gets reflected falling on the surface of the sphere, what will be the direction of the reflected ray? (15)

2. (a) In Cohen-Sutherland line clipping algorithm, the endpoints of a line are first checked for trivial acceptance or trivial rejection so that intersection calculations can be minimized. Describe a technique to perform this checking efficiently. (6)
 (b) Cohen-Sutherland algorithm is not the most efficient line clipping algorithm since it may perform needless clipping if the mentioned checking and clipping are done in a fixed order. Given an example (with appropriate figures) of a case where such unnecessary clipping may occur. (4)
 (c) Suppose you are using Cyrus-Beck parametric line clipping algorithm to determine the clipped portion of a line by a clipping rectangle. After solving the parametric equation, four values of the parameter t are obtained as -0.3, 0.2, 0.9, 1.4. Is it possible to determine the clipped portion from this information? If yes, write down the steps required to do this. If no, explain the reasons. (5)

3. (a) Write down a short note on **spot light**. (5)
 (b) Explain how shadow can be computed using *shadow buffer*. Discuss limitations of using *shadow buffer*. (10)

4. Joey Tribbiani is an actor. One evening, after returning from an audition, he was trying to draw a scene containing two polygons **P** and **Q** using Depth-Sort Algorithm. As the first step of the algorithm, he sorted the polygons according to the farthest z-coordinate of each and found **P** to be farther than **Q**. Being happy with this, he decided that he would draw **P** first and then **Q**. At that instant, Joey's best friend Chandler Bing came beside him and asked what Joey was up to. Joey explained the situation to Chandler and told him about the decision. "Could you be nay more wrong?" exclaimed Chandler after hearing this. Then he pointed out that the Z-extents of **P** and **Q** overlapped and so **P** may obscure **Q**. To determine whether **P** can be drawn before **Q** or not, some tests were needed to be performed. They figured out that the X-extents and Y-extents of **P** and **Q** were also overlapping.

CSE 409

Contd ... Q. No. 4

(a) Write down the further tests that are required to determine whether **P** obscures **Q** or not and also briefly explain how these tests can be performed. **(10)**

(b) If it is found that **P** does not obscure **Q**, can **P** be scan converted before **Q**? If no, explain the reasons. **(5)**

5. A type of Quadratic Koch curve can be drawn following the procedure below:
The curve of **generation 0** is a straight line of unit length.



The **first generation** curve can be drawn from it by dividing the straight line into three equal parts and replacing the middle part with a square shaped bump.

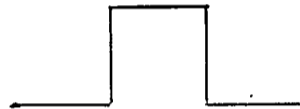

(a) Draw the second generation of the curve. **(4)**

(b) Determine the dimension of the curve. **(4)**

(c) Determine the length of the n-th generation of the curve. **(4)**

(d) Do you think it is a Peano curve? Justify your answer. **(3)**

6. Suppose you are developing a game where the player remains in a room containing many objects. The player can move around in the room and look at the objects from different positions. So, you may be required to draw all the objects from different viewpoints. To make this drawing efficient, you first want to apply a visible surface detection algorithm. Which particular visible surface detection algorithm will you use in this case? Justify your answer. **(15)**

7. (a) Discuss how the specular highlight of an object is affected by increase or decrease in values of the following parameters: **(5)**

(i) Specular reflection co-efficient

(ii) Shininess exponent.

(b) Briefly describe how diffuse and specular light components are calculated according to **Phong model**. **(10)**

8. Suppose a straight line has end points (x_0, y_0) and (x_1, y_1) and slope m where $0 < m < 1$. You are scan converting this straight line using basic incremental algorithm. While doing this, you find out that the scan conversion is taking place slower than you wanted.

(a) What might be the probable reason behind this? **(3)**

(b) Explain how can Midpoint Line algorithm overcome this limitation? **(12)**

CSE 409

9. (a) What do you mean by Aliasing? (3)
- (b) A technique for applying anti-aliasing is area sampling. Area sampling can be done in two ways: **weighted** and **unweighted**. Explain briefly how each of them work and the major difference between them. (8)
- (c) The following polygon is scan converted both edges and spans are treated as intervals that are closed at their minimum value and open at their maximum value. Determine which edges of the polygon will be drawn. (4)

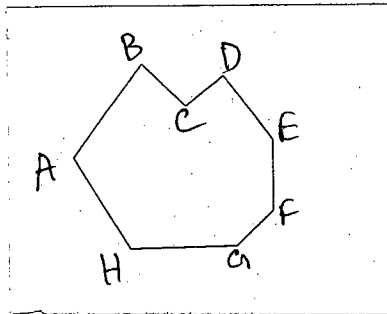

SECTION - B

There are **FOUR** questions in this section. Answer any **THREE**.

10. (a) State and prove the properties of a 3D rotation matrix. (16)
- (b) Using the origin as the center of projection, derive the transformation matrix for a perspective projection onto the plane passing through the point $R_0(x_0, y_0, z_0)$ and having the normal vector $N = n_1i + n_2j + n_3k$. (11)
- (c) Provide a geometric argument supporting the following statement - "A 3D Curve represented by second degree parametric polynomials lines in a plane". (8)
11. (a) Prove that vector form of Rodrigue's formula. (13)
- (b) A camera is located at the origin. Its viewpoint direction and up direction is given by the vectors $i + j$ and $i - j$ respectively. Derive the view transformation matrix, so that the camera looks towards the negative **Z** axis, and its up direction remains along the positive **Y** axis. (10)
- (c) The Catmull-Rom spline is defined by 4 control points P_{-1}, P_0, P_1 and P_2 . The curve goes through the control points and the tangent of the curve at a control point is parallel to the vector joining the previous and next control points. For example, first derivatives at P_0 and P_1 are respectively $\frac{1}{2} \times (P_1 - P_{-1})$ and $\frac{1}{2} \times (P_2 - P_0)$. Derive the basis matrix for the Catmull-Rom spline. You may need the basis of Hermit curve for the derivation, which is given below. You don't need to multiply any matrices. (12)

$$\begin{bmatrix} 2 & -2 & 1 & 1 \\ -3 & 3 & -2 & -1 \\ 0 & 0 & 1 & 0 \\ 1 & 0 & 0 & 0 \end{bmatrix}$$

CSE 409

12. (a) A ray falls on a plane and gets reflected. The direction of the incident ray is given by the vector $\mathbf{i} + \mathbf{j} + \mathbf{k}$ and the plane is defined by the equation $6x + 2y + 3z = 10$. Find the direction on the reflected ray. (9)

(b) Why is translation not a linear transformation in Cartesian space? Why is it necessary for transformations to be linear in order to be incorporated in the graphics pipeline? (4+4)

(c) Write down the composite transformation matrix that transforms the triangle OAB to the triangle ABC on the XY plane as shown in Figure 12. Here points, O, A and B are transformed to points A, B and C respectively. You should use one translation, one rotation, and one scaling operation, not necessarily in the given order. You don't need to multiply any matrices. Use homogeneous coordinates. (11)

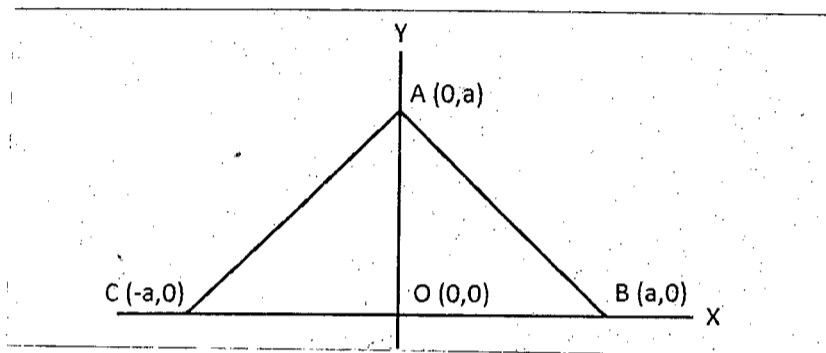

(Figure for Question 12)

(d) The basis matrix of the Bezier curve is given below. Prove that a Bezier curve is bounded by the convex hull of its control points. (7)

$$\begin{bmatrix} -1 & 3 & -3 & 1 \\ 3 & -6 & 3 & 0 \\ -3 & 3 & 0 & 0 \\ 1 & 0 & 0 & 0 \end{bmatrix}$$

13. (a) Consider two planes P_1 and P_2 . P_1 is represented by three points: $(1,1,1)$, $(3,1,4)$ and $(1,2,1)$. P_2 is represented by the equation $3x - 2z = 6$. Prove that P_1 and P_2 are parallel. Determine the perpendicular distance between P_1 and P_2 . (5+4)

(b) You want to align the vector $2\mathbf{i} + 3\mathbf{j} - 6\mathbf{k}$ with the vector \mathbf{j} along the positive Y axis by performing two rotations about the principal axes. First you rotate by an angle θ_1 about the Z axis and then by an angle θ_2 about the X axis. Find θ_1 and θ_2 . (8)

(c) Consider an oblique parallel projection on the XZ plane where the direction of projection is given by the vector $a\mathbf{i} + b\mathbf{j} + c\mathbf{k}$. Derive the transformation matrix for the above parallel projection. Use homogeneous coordinates. (10)

(d) Provide an example where two curves are C_1 continuous, but not G_1 continuous at their join point. Provide an example where two curves are G_1 continuous, but not C_1 continuous at their join point. (8)

The figures in the margin indicate full marks.

Symbols indicate their usual meaning.

USE SEPARATE SCRIPTS FOR EACH SECTION

SECTION – A

There are **FOUR** questions in this section. Answer any **THREE**.

1. (a) Explain the condition of the consumer equilibrium for a single commodity under the cardinal approach to utility analysis and mathematically derive the condition. (8)
 (b) How would you draw the demand curve of the consumer based on the axiom of diminishing marginal utility? (5 1/3)
 (c) What do you know about the fundamental economic problems that every economy has to face? How are these problems solved with reference to the mixed economic system? (10)

2. (a) Differentiate between change in supply and change in quantity supplied. (8)
 (b) Illustrate the mechanism by which market equilibrium of a commodity is established in the free market economy. (5 1/3)
 (c) Let, the Matador Super ball pen has the following demand and supply functions (10)

$$Q_{Dm} = 1850 - 45P_m$$

$$Q_{Sm} = 960 + 65P_m$$
 Find the equilibrium price and quantity of the Matador Super ball pen. If a 15% supplementary tax is imposed on unit price, how much demand would fall compared to the pre-tax demand? What proportion of this tax the suppliers will be able to transfer to the consumers?

3. (a) What do you know about price elasticity and cross-price elasticity of demand. How would you derive the formulae for measuring these two types of elasticity of demand? (8)
 (b) Briefly describe the factors that govern the size of the coefficient of price elasticity of demand? (5 1/3)
 (c) The demand function of a commodity X is given by (10)

$$Q_{dx} = 1590 - 25P_x + 0.008M + 3.8P_y - 7P_z$$
 Where price of X (P_x) is Tk. 60, price of Y (P_y) is Tk. 80, price of Z (P_z) is Tk. 100 and the level of income (M) is Tk. 60000. Find the price and cross-price elasticities of demand for commodity X. Define the relationship between X and each of the other two commodities based on the results.

HUM 275/CSE

4. Write short notes on any THREE of the following (23 1/3)
- (i) Substitution effect and income effect of a price change
 - (ii) Other than price, factors interacting in the software market in Bangladesh
 - (iii) Market equilibrium
 - (iv) Properties of an Indifference curve and marginal rate of substitutions (MRS).

SECTION – B

There are **FOUR** questions in this section. Answer any **THREE**.

5. (a) What is fixed cost and variable cost? Give examples of fixed cost and variable cost. (3 1/3)
- (b)

Quantity	TC	TFC	TVC	AFC	AVC	AC	MC
0		20	0				
1		20	30				
2			55				
3			75				
4			105				
5			155				
6			225				
7			315				
8			425				

Complete this table of costs. (10)

(c) Draw average cost (AC) and marginal cost (MC) from above table (in question b) and discuss the relationship between the AC and MC. (10)

6. (a) What are the types of profit a firm can earn, describe. (3 1/3)
- (b) Why does a monopoly arise in the market? Discuss with examples. (10)
- (c) Show the equilibrium of monopoly market graphically and explain. (10)
7. (a) What is national income and name different measurements of national income. (3 1/3)
- (b) Explain the concept of nominal GDP and real GDP. (4)

HUM 275/CSE

Contd ... Q. No. 7

(c)

Output	2014		2015		2016	
	P ₁₄	Q ₁₄	P ₁₅	Q ₁₅	P ₁₆	Q ₁₆
Bread	10	200	15	210	20	195
Apple	5	500	4	600	10	450
Rocket	1000	3	1100	4	1500	2
Computer	75	80	75	90	80	80

From the given information calculate nominal GDP and real GDP.

(10)

(d) Calculate the growth rate of nominal GDP and real GDP from question (c) and write a comparative note.

(6)

8. (a) What is inflation?

(3 1/3)

(b) Describe the demand pool inflation and cost push inflation.

(10)

(c) State the costs of inflation in detail.

(6)

(d) Show the relationship of inflation and unemployment and explain why does such relationship exist?

(4)

SECTION – A

There are **FOUR** questions in this section. Answer any **THREE**.

1. (a) Describe Vertex-Cover problem. Give a greedy 2-approximation algorithm for Vertex-Cover of an undirected graph. Analyze the approximation ratio. (12)
- (b) (i) If you use greedy 2-approximation algorithm for determining a Vertex-Cover of a complete binary tree CBT3 of 3 levels (7 nodes), how many vertices will be chosen in the worst case? For a complete binary tree CBT_n of n levels, find a generic form for worst case output of the algorithm. (6+5+6=17)
- (ii) Find out the value of optimal vertex cover for CBT3, and find a generic form for determining the optimal vertex cover for CBT_n.
- (iii) Give an efficient algorithm that finds an optimal vertex cover for an **arbitrary** tree in linear time.
- (c) Consider each of the following words as a set of letters: {arid, dash, drain, lost, slate, thread}. Show which set cover GREEDY-SET-COVER produces when ties are broken in favor of the word that appears earlier in the dictionary. (6)
2. (a) Suppose that the vertices for an instance of the Rectilinear Traveling Salesman (R-TSP) Problem are points in the plane. You can think of R-TSP as a TSP in a planar grid, where the traveler can only walk in axis-parallel direction. Traveling cost from point u to v is the Manhattan Distance between them: $\text{abs}(u.x - v.x) + \text{abs}(u.y - v.y)$. Now answer the following questions: (7+13=20)
- (i) Show that an optimal R-TSP tour never crosses itself.
- (ii) Find an approximation algorithm for R-TSP. Analyze the approximation ratio.
- (b) For the given graph shown in Figure 1 use branch-and-bound technique to find the optimal geometric TSP tour and simulate the steps with branching tree. (10)

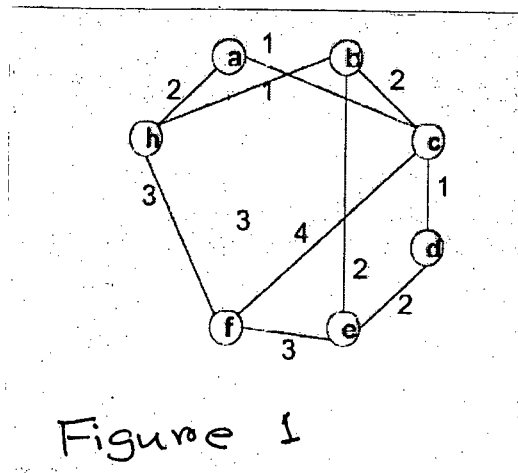

- (c) Design an exact algorithm for solving the Weighted Vertex Cover problem using the bit masking DP technique. (5)

CSE 461

- 3. (a) Design a Linear Programming model for Set Cover problem. Describe a randomized rounding technique for your LP solution such that probability of an item not covered is inversely proportional to polynomial of size of the Universe Set. Provide proof of correctness. (15)
- (b) What is Load Factor of a Dynamic Table? Using Potential Method discuss the complexity of a series of n INSERTION operations on a Dynamic Table data structure. (12)
- (c) You are doing n INCREMENT operations on a k -bit binary counter which was in reset state initially. By Aggregate Analysis show that amortized cost per operation is $O(1)$. Also show that if a DECREMENT operation were included, n operations could have cost as much as $O(nk)$ time. (8)

- 4. (a) Describe the properties of Monte Carlo Algorithms. Consider three $n \times n$ matrices A , B and C . You suspect that $C = AB$. How can you verify whether or not this is so? Of course, you can't use the traditional $O(n^3)$ matrix multiplication algorithm as the value of n can be large. Also very briefly write the correctness and complexity of the approach. (10)
- (b) Write Space and Search complexity of a skip list of n elements. (15)
- (c) Write the split and join operation of the Splay Tree Data structure. Draw different stages of the tree during the insertion of value 7 in the splay tree of Figure 2. (10)

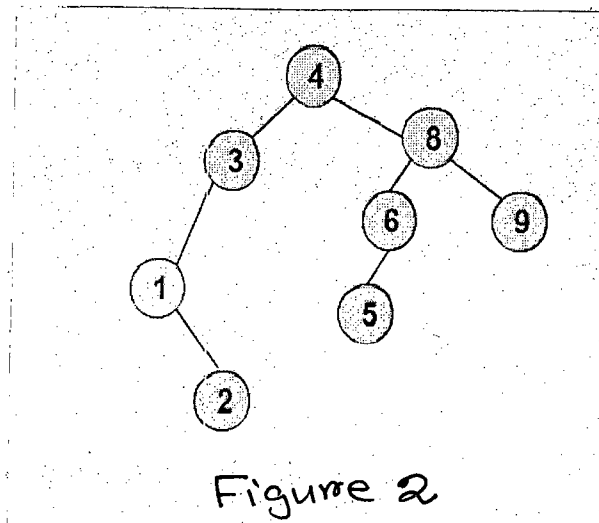

SECTION - B

There are **FOUR** questions in this section. Answer any **THREE**.

- 5. (a) Suppose you need to search a given Text T for an occurrence of any one of a given set of k patterns. How can you extend the Rabin-Karp method to solve this problem? Assume that all the k patterns have the same length. (10)
- (b) How can you determine whether a text T is a cyclic rotation of another string T' in linear time? For example, 'car' and 'arc' are cyclic rotation of each other. (10)
- (c) Briefly describe how you can solve the following problems using suffix trie and suffix array. Also mention the time complexity of your solution. (15)
 - (i) Number of distinct substrings of a given text T .
 - (ii) Length of the longest repeated substring within a given text T .

CSE 461

- 6. (a) What is the block alignment problem? Discuss how Four Russian Speed Up technique makes the block alignment problem time efficient. (15)
(b) Prove that if a permutation π contains a decreasing strip, then there exists a reversal that decreases the number of breakpoints in π . (10)
(c) Define i-string, ILCS and CLCS. How many i-strings of length 5 can be constructed from an alphabet set of size 4? How many of them will contain no repeated characters? (10)

- 7. (a) Define an optimization problem and its decision version. Suppose an algorithm A can solve a decision problem in polynomial time. How can algorithm A be used to solve the corresponding optimization problem efficiently? (8)
(b) How do you prove Problem A and Problem Y are equally hard. Prove that, Independent set \leq_p Set Packing. (10)
(c) Discuss the general strategy of proving a new problem is NP-complete. (5)
(d) Prove that, 3-coloring is NP-complete using a reduction from 3-SAT. (12)

- 8. (a) Describe the problem classes P, NP, NPC NP-hard and PSCAPE with examples. Also show the relationship among them. (10)
(b) Write down the algorithm for finding maximum independent set in a graph using branch and reduce technique. Using a branching tree show the steps of the algorithm and find a maximum independent set of the graph in the following figure. Also prove that, the time complexity of the algorithm is $O(3^{n/3})$. (15)

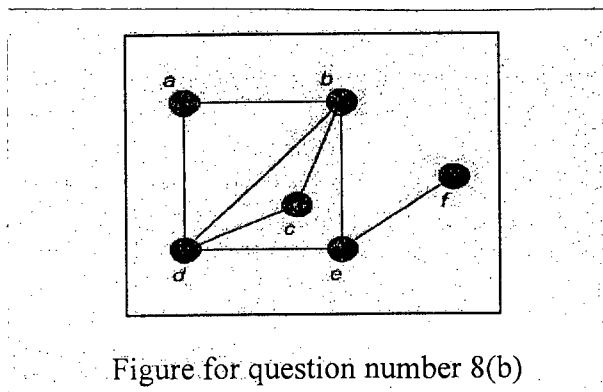

- (c) Define linear speedup and slackness with respect to multithreaded algorithms. What are the significance of them? (5)
 - (d) Prove that the running time T_p of any multithreaded computation scheduled by a scheduler on an ideal parallel computer with P processors is within a factor of 2 of optimal. (5)
-

SECTION – A

There are **FOUR** questions in this section. Answer any **THREE**.

1. (a) Draw a complete figure containing all the components of learning. Describe each component in short. (15)
 (b) Discuss about the complexities of the unknown target function f and hypothesis set \mathcal{H} in case of learning. How does the noise affect the unknown target function? (10+5=15)
 (c) What is the chromosomal representation technique in an evolutionary programming? What are the possible mutation operators to create an offspring in evolutionary programming? (2.5+2.5=5)

2. (a) Briefly explain the following concepts with the necessary examples. (4+4+4+3=15)
 (i) Growth function, (ii) Break point, (iii) VC-dimension and (iv) Shattering.
 (b) Briefly describe chromosomal representation technique, different generic operators, parent selection technique and survivor selection technique of generic programming with necessary examples. (3+8+2+2=15)
 (c) Why is the VC bound very loose? (5)

3. (a) Discuss the effect of model complexity on bias and variance. How do the learning curves help to decide whether more data may help very much for better learning? (8+7=15)
 (b) How is the bin example similar to learning? Write down the Hoeffding inequality for a single hypothesis. How can it be extended for multiple hypotheses? (4+3+8=15)
 (c) What has made cosine similarity different from the other distance measures for k-nearest neighbor selection? What is the importance of IDF in cosine similarity? (2+3=5)

4. (a) How do we get 'VC-inequality' from 'Hoeffding inequality for multiple hypotheses'? Briefly describe with pictorial proof and other related figures. (15)
 (b) How do the generative learning algorithms differ from the discriminative learning algorithms? Where should we use Gaussian discriminant analysis and where should we use Naïve Bayes? What is the strong assumption of Naïve Bayes? Why Laplace smoothing factor is necessary for Naïve Bayes? (4+4+2+5=15)
 (c) How does generic programming (GP) differ from the other evolutionary algorithms? (5)

CSE 471

SECTION – B

There are **FOUR** questions in this section. Answer any **THREE**.

5. (a) Derive the Generalized Linear Model (GML) for the classification of an input dataset into k classes. Assume necessary probabilistic distribution for the data. (15)
- (b) Write down the Markov Decision Process based Q-learning (one type of reinforcement) algorithm. How does Q-learning for deterministic Markov decision processes converge? (12+8)
6. (a) Explain batch gradient descent and stochastic gradient descent based linear regression algorithms. When is stochastic gradient descent often preferred over batch gradient descent? (10+5)
- (b) Show that under certain probabilistic assumptions on the data, least-squares regression corresponds to finding the maximum likelihood estimate of parameter, θ . (15)
- (c) Define Inductive and Transductive learning? (5)
7. (a) What is Bagging? How is it related to bias-variance tradeoff? (5+5)
- (b) Draw a block diagram of AdaBoost ensemble method by showing its different steps? How do you choose weights for different hypotheses in AdaBoost? (10+5)
- (c) What is the main difference between bagging based decision tree and random forest based decision tree? (10)
8. (a) Consider data with two Boolean attributes (A, B). The data set consists of 203 examples labeled with + and – outputs. Based on the information gain concept, draw the decision tree. (15)
- < (A=0, B=0), – >: 50 examples
< (A=0, B=1), – >: 50 examples
< (A=1, B=0), – >: 3 examples
< (A=1, B=1), + >: 100 examples
- (b) How should you modify the information gain based attributes selection method to handle attributes with *many* values and attributes with *missing* values? (10)
- (c) Why does overfitting occur in a decision tree based classification? What are the remedies to avoid overfitting? (5+5)
-

SECTION – A

There are **FOUR** questions in this section. Answer any **THREE**.

1. (a) Briefly describe the reasons behind the pinch-off in the channel of an NMOS transistor using appropriate figures. (10)
- (b) Sketch a static CMOS gate to compute the function, $Y = \overline{(A + B) \cdot (C \cdot D + E)}$. What is the problem of using the general logic gate given in Figure 1(b) for designing a non-inverting function? (5+5=10)

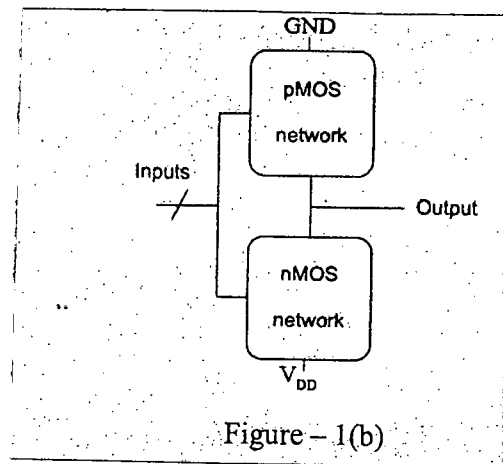

- (c) From the I-V characteristics graph of an ideal $4/2\lambda$ NMOS transistor, at $V_{gs} = 0.8V$, the saturation voltage and current are $0.46V$ and $65\mu A$, respectively. (i) Calculate β , (ii) Calculate the value of μC_{ox} , (iii) Plot curves for $V_{gs} = 0.1V, 0.5V$ and $0.9V$. (Where symbols have their usual meanings). (4+4+7=15)
2. (a) What is a Pass Transistor? What is the problem of using it? How can we overcome this problem? (2+4+4=10)
- (b) Draw a positive-level-sensitive D latch. Using the D latch, draw a negative-edge triggered D flip-flop. Briefly explain how the D flip-flop works. (3+4+3=10)
- (c) Design and draw the diagrams of 8 : 1 Inverting Multiplexer in two ways. Compare them by calculating the number of MOSFETs necessary for each of the designs. (5+5+5=15)

CSE 481

3. (a) Define Horizontal and Vertical Constraints for detailed routing. Explain with a suitable example when dogleg is necessary for detailed routing. (5+5=10)
- (b) Find out the starting terminals and net ordering according to General River Routing algorithm for the Figure 3(b). (3+7=10)

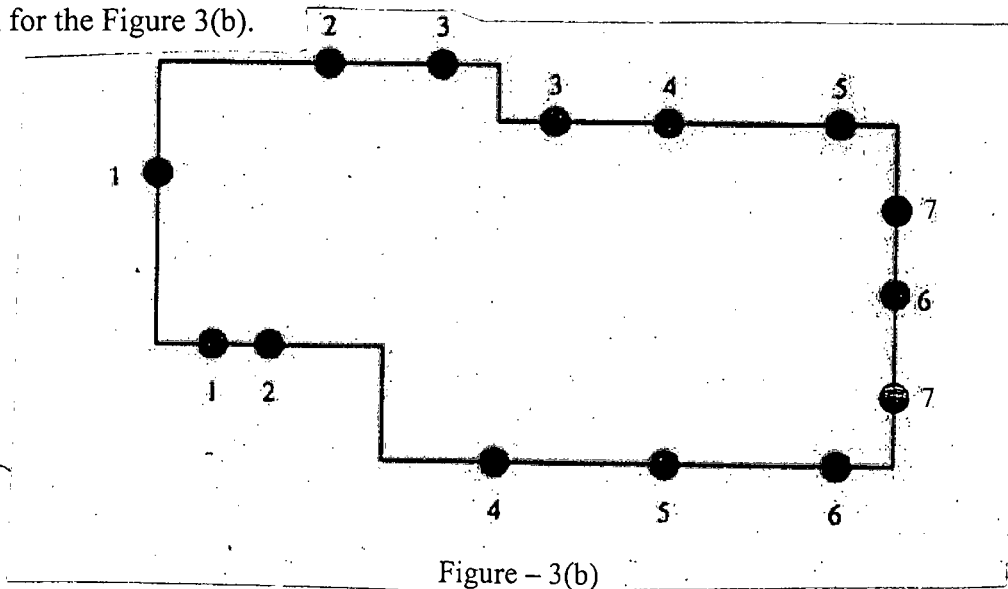

Figure - 3(b)

- (c) Explain the effects of the two parameters namely "range" and "routine sequence" in Dogleg Router with a suitable example. (10)
- (d) Why is Basic LEA a special case of Dogleg Router? What are the advantages of Dogleg Router over Basic LEA? (2+3=5)
4. (a) Describe (i) Regularity, (ii) Modularity, (iii) Locality, (iv) Scaling for VLSI design. (2+2+2+2=8)
- (b) Draw the CMOS Inverter mask set. (12)
- (c) Briefly describe the CMOS fabrication process for a CMOS Inverter at different steps of fabrication. (15)

SECTION - B

There are **FOUR** questions in this section. Answer any **THREE**.

5. (a) Describe a design style that reduces the design time and cost but increases the area requirement compared to the other design styles. (8)
- (b) Illustrate the steps of physical design cycle with the help of examples. (12)
- (c) Illustrate the method of reducing cut size of partitioning using component replication with a suitable example. (6)
- (d) What is the difference between on-chip delay and off-chip delay? (6)
- (e) What do you mean by 'terminal count' of a block in VLSI circuits? (3)

CSE 481

6. (a) Define slicing floorplan, non-slicing floorplan and hierarchical floorplan. Describe different graph representations of VLSI floorplans with illustrative examples. **(6+8)**
- (b) Formulate the partitioning problem in terms of hyper-graph. Explain the partitioning problems for full-custom and standard cell design styles. **(7+4+4)**
- (c) What is the objective of pin assignment in VLSI design? Formulate the pin assignment problem using this objective. **(6)**

7. (a) What are the drawbacks of KL (Kernighan-Lin) algorithm for circuit partitioning? How does FM (Fiduccia-Mattheyses) algorithm differ from KL algorithm? Discuss FM algorithm using an example. How does data structure improve the performance of FM algorithm? **(4+4+6+6)**
- (b) Explain the pros and cons of the Goldberg and Burstein partitioning algorithm. From the graph shown in the Figure 7(c), find a matching M in the graph and apply the Goldberg and Burstein algorithm for two iterations. **(5+10)**

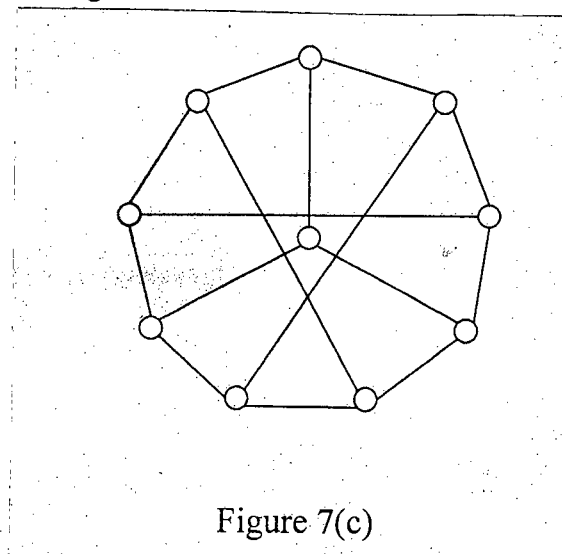

8. (a) Distinguish between Global Routing and Detailed Routing. **(6)**
- (b) Describe Lee's maze routing algorithm. Determine its time and space complexity. How can these complexities be improved? **(6+2+8)**
- (c) Describe the basic concepts of line probe algorithm with an illustrative example. Mention the difference between Mikami-Tabuchi's algorithm and Hightower's algorithm. **(6+7)**
-

BANGLADESH UNIVERSITY OF ENGINEERING AND TECHNOLOGY, DHAKA

L-4/T-2 B. Sc. Engineering Examinations 2014-2015

Sub : **HUM 371** (Financial and Managerial Accounting)

Full Marks : 140

Time : 3 Hours

The figures in the margin indicate full marks.

USE SEPARATE SCRIPTS FOR EACH SECTION

SECTION – AThere are **FOUR** questions in this Section. Answer any **THREE**.

1. (a) What is the difference between expense and loss? Explain with example. (3 1/3)
- (b) Mr. Alex has started his computer service business on April 1st of 2015. The following transactions occurred during the month. (20)

April-1:	Invested cash in the business Tk. 30,000.
„ -2:	Purchased computer terminals for Tk. 20,000 on account.
„ -3:	Purchased supplies for Tk. 1500 cash.
„ -6:	Performed computer services Tk. 8000 cash
„ -8:	Paid dues for purchase on account in April 2.
„ -19:	Provide services on credit to a customer Tk. 5000.
„ -25:	Paid expenses for the month: rent Tk. 1,000; salaries Tk. 800 and utilities bill Tk. 200.
„ -30:	Received Tk. 5,000 from the customer who has been previously billed in April-19.

Required:

- (i) Show the effects of transactions on accounting equation.
- (ii) From the equation analysis prepare the income statement for April 30, 2015.
2. (a) What is accrual basis and cash basis of accounting? (4 1/3)
- (b) Mrs. Sherlin opened a consulting firm on May 1, 2015. Following transactions happened for the month of May. (19)

May-1:	Invested Tk. 2,00,000 cash in the business
„ -3:	Purchased decorated office room for Tk. 150,000 cash.
„ -5:	Paid advertising expense of Tk. 7000.
„ -10:	Received Tk. 30,000 as consultancy fees.
„ -18:	Billed a client for services performed on credit Tk. 8500.
„ -25:	Withdraw Tk. 5000 for personal use.
„ -28:	Received dues on services provided on credit.
„ -29:	Purchase supplies for office Tk. 2000 in cash.
„ -30:	Paid salary to the office staff Tk. 10,000.

Required: Journalize the transactions in a good form.

3. (a) What is revenue recognition principle? Explain with example. (3 1/3)

HUM 371(CSE)

Contd ... Q. No. 3

(b)

Stereo Company
Trial Balance
June 30, 2014

(20)

Account Titles	Debit(Tk.)	Credit(Tk.)
Cash	8,000	
Accounts Receivable	6,000	
Supplies	2,000	
Prepaid Insurance	3,000	
Equipment	15,000	
Accounts Payable		4,500
Unearned Service Revenue		4,000
Owner's Capital		22,600
Service Revenue		7,900
Salaries and Wages Expense	4,000	
Rent expense	1,000	
Total	<u>39,000</u>	<u>39,000</u>

Other data:

- Supplies on hand on June 30 are Tk. 750.
- Utility bill accrued Tk. 150.
- The insurance policy is for a year.
- Tk. 2800 of unearned revenue has been earned
- Salaries of Tk. 1900 are accrued on June 30.
- Depreciation of equipment Tk. 250 per month.
- Services performed but not recorded Tk. 1200

Required: (i) Prepare the adjusting entries of June 30, 2014

(ii) Prepare an adjusted trial balance on June 30, 2014.

4.

Erin Corporation
Trial Balance
December 31, 2014

(23 1/3)

Account Titles	Debit(Tk.)	Credit(Tk.)
Cash	5,300	
Accounts Receivable	10,800	
Supplies	1,500	
Prepaid Insurance	2,000	
Equipment	27,000	
Accumulated Depreciation-Equipment		5,600
Notes Payable		15,000
Accounts Payable		6,100
Salaries Payable		2,400
Internet Payable		600
Owner's Capital		13,000
Owner's Drawings	7,000	
Service Revenue		61,000
Advertising expense	8,400	
Supplies expense	4,000	
Depreciation expense	5,600	
Insurance expense	3,500	
Salaries expense	28,000	
Internet Expense	<u>600</u>	
Total	<u>1,03,700</u>	<u>1,03,700</u>

HUM 371(CSE)

Contd ... Q. No. 4

Tk. 1000 of prepaid Insurance expired during the year.

Required: (i) Prepare a non-classified Income statement and owner's equity statement.

(ii) Prepare a classified balance sheet (Note payable in long term)

(iii) Identify Profit margin ratio and Current ratio.

SECTION – B

There are **FOUR** questions in this Section. Answer any **THREE**.

5. (a) Only variable costs can be differential cost. Do you agree? Explain. (6)

(b) Define the following cost concept with example: (6)

- (i) Opportunity cost.
- (ii) Relevant range.
- (iii) Committed fixed cost.

(c) The following cost and inventory data taken from the accounting records of Toma Construction Company for the year ended on 31st December, 2014.

<u>Inventories</u>	<u>January 1,2014</u>	<u>31st December, 2014.</u>
Direct material	Tk.7,000	Tk.15,000
Work-in-process	10,000	5,000
Finished goods	20,000	35,000

	<u>Cost Incurred</u>	<u>Amount (Tk.)</u>
	Direct labor cost	70,000
	Purchase of raw materials	118,500
	Indirect labor	30,000
	Maintenance, factory equipment	6,000
	Advertising expense	90,000
	Insurance, factory	800
	Sales commission	35,000
	Administrative managers salary	55,000
	Supervisors salary	12,000
	Rent, factory	30,000
	Rent, office	25,000
	Rent for showroom	13,000
	Utility (70% factory, 30% for office)	15,000
	Supplies (60% factory, 40% for office)	3,000
	Power and electricity	2,500
	Fuel for factory equipment	700
	Depreciation, factory equipment	30,000
	Legal fees	15,000

Required: (i) Prepare a cost of goods sold statement in a good form.

(11 1/3)

HUM 371(CSE)

6. (a) What do you understand by cost structure? (5)

(b) Bogside farm and Sterling farm are two blueberry farms. Bogside farm has higher variable cost as it depends on migrate workers to pick its berries by hand, whereas Sterling Farm has higher fixed cost as a result of its investment in expensive machine to pick its berries. Following are the income statement of these two blueberry farms:

	<u>Bogside farm</u>	<u>Sterling farm</u>
Sales	Tk. 100,000	Tk. 100,000
Less: Variable expense	60,000	30,000
Contribution margin	40,000	70,000
Less: Fixed expense	30,000	60,000
Net profit	<u>10,000</u>	<u>10,000</u>

Required:

Considering CM ratio, break-even point and margin of safety expression which farm has the better cost structure? (8 1/3)

(c) Simens company manufactures and sales a specialized cordless telephone for the most electromagnetic radiation environments. The company’s contribution format income statement for recent year is given below:

	<u>Total(Tk.)</u>	<u>Per unit(Tk.)</u>	<u>Percentage(%)</u>
Sales (20,000 units)	10,00,000	50	100
Less: Variable expense	<u>800,000</u>	<u>40</u>	?
Contribution margin	200,000	<u>10</u>	?
Less: Fixed cost	<u>150,000</u>		
Net profit	<u>50,000</u>		

Management is anxious to increase company’s profit and has asked for an analysis of a number of items.

Required:

- (i) Compute the company’s CM ratio and variable expense ratio.
- (ii) Compute company’s break-even-points in units and Tk.

(10)

HUM 371(CSE)

Contd ... Q. No. 6(c)

(iii) Assume that sales increase by Tk. 400,000 next year. If cost behavior patterns remain unchanged, by how much will the company's net operating income increase?

(iv) Refer the original data. Assume that next year management wants the company to earn a profit of at least Tk. 90,000. How many units will have to be sold to meet this target profit?

(v) Refer to the original data. Compute the company's margin of safety.

7. (a) In what situation, absorption costing will result higher net income than variable costing? Why? (5 1/3)

(b) For the income year ended on December 31, 2015; you have been given the information below:

Selling price per unit	Tk.50
<u>Manufacturing cost (Tk.) :</u>	
Direct material cost per unit	8
Direct labor cost per unit	7
Variable manufacturing cost per unit	5
Fixed manufacturing cost for the period	Tk.100,000
<u>Selling and administrative cost(Tk.)</u>	
Variable cost per unit	2
Fixed cost for the period	Tk.80,000

During the year, a total 10,000 units produced but only 8,500 units sold.

Required:

(i) Calculate the product cost per unit under absorption costing system and variable costing system.

(ii) Prepare income statement using under absorption costing system and variable costing system.

(iii) Reconcile the amount of profits under two costing systems.

8. (a) Brentline Hospital is interested in predicting future monthly maintenance Cost for budgeting purpose. The senior management team believes that maintenance is a mixed cost and that the variable portion of this cost is driven by the number of patient days. Each day a patient is in the hospital counts as one patient day. The Hospitals chief financial office gathered the following data for the most recent seven months period:

Month	Activity level	Maintenance cost (Tk.)
January	5,600	7,900
February	7,100	8,500
March	5,000	7,400
April	6,500	8,200
May	7,300	9,100
June	8,000	9,800
July	6,200	7,800

HUM 371(CSE)

Contd ... Q. No. 8(a)

Required:

(9)

- (i) Using high low method find out variable and fixed maintenance cost for the hospital.
- (ii) Express the fixed and variable components of admitting cost as a cost formula in the form $Y = a + bX$.
- (iii) Suppose in August the hospital is expecting that 5,500 patient will come. Now Find out the budgeted variable cost, fixed cost and total cost for the month of August.

(b) Write down the methods of mixed cost analysis.

(5)

(c) "Yellow Company" provides management consulting services to government and corporate clients. It has two supports departments-Finance (FIN) and information technology (IT) – and two operating departments- Government Consulting (GOVT) And Corporate Consulting (CORP). For the year 2014, the following information were available:

Budgeted overhead before allocation (₹)	Support Dept.		Operating Dept.		Total
	FIN	IT	GOVT	CORP	
	60,000	24,000	80,000	120,000	284,000
Support work by FIN	-	25%	40%	35%	100%
Support work by IT	10%	-	30%	60%	100%

Required:

(9 1/3)

Allocate two supports departments cost to the two operating departments by using-

- (i) Direct method.
- (ii) Step-down method.

SECTION – A

There are **FOUR** questions in this section. Answer any **THREE**.

1. (a) Outline an algorithm to compute the minimum-area bounding rectangle of a convex polygon in linear time. (15)
 (b) Prove that the lower bound on the time complexity for constructing the convex hull of a set of n points in 2D is $\Omega(n \lg n)$. (10)
 (c) How can you find a tangent to a convex polygon from a point in $O(\lg n)$ time? (10)

2. (a) Briefly describe the *Quick Hull* algorithm. Is the run-time of this algorithm output-size sensitive? Analyze its time complexity. (14)
 (b) Use *Plane Sweep* algorithm to find the closest pair of points in a set of n points in $O(n \lg n)$ time. (15)
 (c) Define a *Canonical Ordering* of a triangulated plane graph. (6)

3. (a) Illustrate the data structure that facilitates traversing all faces in a planar graph in linear time. (10)
 (b) Briefly describe the implementation challenges associated with the linear time *Canonical Ordering* algorithm. (13)
 (c) Sketch the idea behind the *Shift* algorithm. Write down the mathematics involved. (12)

4. (a) For the graph shown in Figure for Q. No. 4(a), find the *Schnyder Labeling*, the *Realizer* and the *planar straight line grid drawing* of the graph using the *Realizer* method. Show each step. (30)

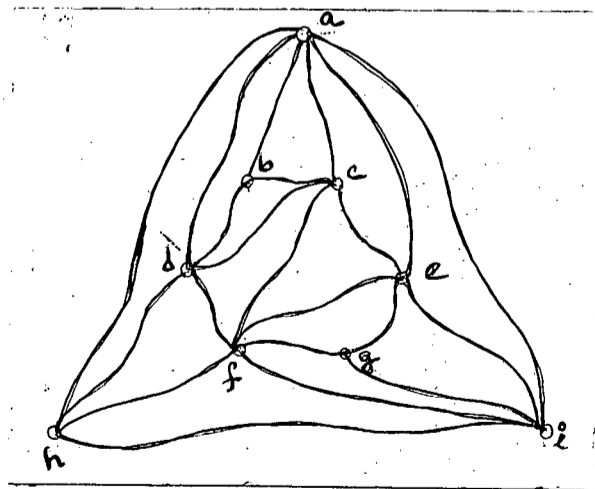

Figure for Q. No. 4(a)

- (b) Show that the *Realizer* method finds a straight line drawing on a grid of size $(n-2) \times (n-2)$. (5)

CSE 463

SECTION – B

There are **FOUR** questions in this section. Answer any **THREE**.

5. (a) Prove the followings, in sequence, for a simple polygon and its triangulation. Use earlier results to prove the next ones: **(5×4=20)**
- (i) Every simple polygon must have at least one strictly convex vertex.
 - (ii) Every simple polygon with $n \geq 4$ vertices has a diagonal.
 - (iii) Every triangulation of a simple polygon has $n-3$ diagonals and $n-2$ triangles.
 - (iv) The sum of the internal angles of a simple polygon of n vertices is $(n-2)\pi$.
 - (v) Every polygon of $n \geq 4$ vertices has at least two non-overlapping ears.
- (b) What are the conditions that a simple polygon needs to satisfy to be strictly y-monotone? Prove that your conditions are necessary. **(5+10=15)**
6. (a) Analyze the performance of a 2-dimensional kd-tree. Give an example of a 2-dimensional kd-tree consisting of 15 points. **(15+5=20)**
- (b) Describe the triangulation algorithm of a polygon by ear removal and compute its complexity. **(10)**
- (c) Analyze the time complexity of the divide and conquer algorithm to compute the Voronoi diagram of n sites. **(5)**
7. (a) Give an algorithm which will find the largest empty circle whose center is in the convex hull of a set of n sites. Prove the correctness of the algorithm. **(5+10=15)**
- (b) Give an $O(n \log n)$ time randomized incremental algorithm for Delaunay triangulation and prove the correctness of the algorithm. **(10+10=20)**
8. (a) Write down the properties of Delaunay triangulation. **(5)**
- (b) Give an example of a simple polygon consisting of 15 vertices where $O(n^2)$ algorithm of triangulation by ear removal performs worst. Show the output of the algorithm for the polygon (order of the diagonals). **(10)**
- (c) Prove that $\lfloor n/3 \rfloor$ guards are sometimes necessary and always sufficient for guarding a simple polygon of n vertices. **(20)**
-

SECTION – A

There are **FOUR** questions in this section. Answer any **THREE**.

1. (a) Explain the concept of "Broadcom Pin Numbering" and "Board Pin Numbering" in regards to Raspberry Pi. (5)
 - (b) Although Raspberry Pi is extensively used in embedded systems, it does not have any built-in ADC. Explain the reason behind this. (5)
 - (c) Construct a circuit and write down the necessary code to get reading from LM35 using Raspberry Pi and MCP3008. You can simply dump the reading to your terminal. (25)

 2. (a) What do you mean by a "flyback diode"? (5)
 - (b) Construct a circuit to control a 12V, 0.24A DC fan from Arduino Uno. Accommodate a push button, so that the fan can be controlled through that button. You need to clearly state values of each of the components in your circuit diagram. Further assume that you have the following models of NPN BJTs available for use. Identify the model(s) that you can use in this scenario along with calculations justifying your decision. (30)
- | Name | $I_{C(max)}$ | $V_{CEO(max)}$ | $h_{FE(sat)}$ | $V_{BE(sat)}$ |
|-------|--------------|----------------|---------------|---------------|
| BJT-A | 1.5A | 45V | 10 | 0.8V |
| BJT-B | 3A | 40V | 10 | 0.7V |
| BJT-C | 0.1A | 45V | 10 | 0.7V |
| BJT-D | 5A | 60V | 250 | 0.7V |
3. (a) What setup can we take to efficiently use the scarce memory (Flash and SRAM) of ATmega328p? (10)
 - (b) Briefly describe a method of hardware debouncing with circuit diagram. (5)
 - (c) Explain how SCRs work using a rough schematic. (20)

 4. (a) Explain the terms bidirectional, half-duplex, and full-duplex in regards to communication. What type of communication does SPI fall under? (10)
 - (b) If an SPI master has to communicate with three slaves, how many pins in total should be reserved for SPI communication in the master? Write down their names. (5)

CSE 483

Contd ... Q. No. 4

- (c) Suppose two sensors are connected to Raspberry Pi through SPI communication. Both of them are connected to the same SPI bus. Is it safe to send the same command to the sensors at the same time? Is it safe to read data from the sensors at the same time? (10)
- (d) "As address frame in 12C contains 8 bits, we can have 256 unique addresses" – do you agree? Why or why not? (10)

SECTION – B

There are **FOUR** questions in this section. Answer any **THREE**.

5. (a) What is understood by 'bus'? (5)
- (b) What are different types of bus that can be found in computers? Discuss them. (10)
- (c) Once ISA bus was extensively used in computers. Nowadays it can not be found in computers. What were the limitations/disadvantages of ISA bus? (10)
- (d) PCI bus drives out ISA bus from computers. What are the advantages of PCI bus? (10)
6. (a) Tough we had a good bus like PCI, why do we need AGP? (12)
- (b) What is interleaving in hard disk? Why is it necessary? (12)
- (c) Why was SCSI preferred over ST-506 or ESDI? (11)
7. (a) Name different types of barcode readers. Explain the operation of any one type. (13)
- (b) Calculate the check-digit for a product having following UPC-A barcode: 03600029145. All the steps should be clearly shown. (10)
- (c) What is an RTOS? What is its usage? (12)
8. (a) Why was USB developed? What advantages does it offer over the then existing systems? What limitations are still there in USB? (15)
- (b) What is new connector types specified in USB 3.0? Discuss them. (10)
- (c) Discuss the protocols used by USB. (10)
-

SECTION – A

There are **FOUR** questions in this section. Answer any **THREE**.

1. (a) Why is the search space restricted to $[-p, p] \times [-p, p]$ in template matching, where the symbols have usual meanings? Justify the typical values of p . (10)
 (b) Show that a set of basic perceptrons can optimally separate a set of linearly non-separable examples if an appropriate feature transformation is used. How does a nonlinear SVM solve this problem using feature transformation? Explain with necessary examples. What problem does this transformation introduce in SVM? How is kernel trick used to solve it? (8+7+5+5=25)

2. (a) With appropriate examples, justify that a two-layer perceptron can separate classes each consisting of unions of some of polyhedral regions but not any union of such regions. How does a three-layer perceptron can solve this problem? (12+8=20)
 (b) Show that the objective function to be optimized by a linear SVM is independent of the separability issue (e.g., linearly separability or non-separability) of the example patterns. (15)

3. (a) Define the primitives to represent the digits '6' and '9' in picture description language (PDL). Find all the components of the grammars and the associated strings of primitives to recognize and represent these digits. (17)
 (b) Using the primitives defined in 3(a), find (i) the corresponding attributed graphs (18)
 (ii) the matched graph, and (iii) the maximal clique.

4. (a) Does a perceptron algorithm provide a unique classifier if the training examples are linearly separable? Justify. (12)
 (b) Explain why and how the activation function of a neural network differs from that of a perceptron. (10)
 (c) Explain the significances of internal energy and external energy in deformable template matching. Show relations among them. (13)

CSE 473

SECTION – B

There are **FOUR** questions in this section. Answer any **THREE**.

5. (a) Define mathematical representation of a pattern using feature vectors. Does adding correlated features improve recognition performance? Explain. **(6+3)**
- (b) Mention three requirements of a feature to be chosen for classification purpose. **(6)**
- (c) Define the posterior probability of being classified into class $C = c_k$ for a feature vector consisting feature set $A = \{a_1, a_2 \dots a_n\}$. Formulate the posterior probability of being classified into class c_k for a naïve Bayes classifier from your previous definition. Explain the intuition behind the formulation. **(4+4+4)**
- (d) Let us assume all the features are continuous and for a given class $C = c_k$, feature a_i follows a Gaussian distribution $N(\mu_{ik}, \sigma_{ik})$. Write the simplified posterior probability of being classified into class c_k . **(8)**
6. (a) Probability of a person being nonallergic is 0.7, **(6+6)**
Probability of a person being nonsmoker is 0.25
Probability of having Flu when the corresponding person is
- (i) nonsmoker and nonallergic is 0.25
 - (ii) nonsmoker and allergic is 0.55
 - (iii) smoker and nonallergic is 0.45
 - (iv) smoker and allergic is 0.75
- Probability of having Asthma when a person is
- (i) nonsmoker is 0.2
 - (ii) smoker is 0.85
- Probability of having Runny nose when a person has
- (i) Flu is 0.85
 - (ii) no Flu is 0.2
- Probability of having Cough when a person has
- (i) neither Flu nor Asthma is 0.1
 - (ii) only Flu is 0.6
 - (iii) only Asthma is 0.4
 - (iv) both Flu and Asthma is 0.8
- You can safely ignore all other possible dependencies. From the above information, draw the corresponding Bayesian belief network. Annotate the network with conditional probability tables. For this Bayesian belief network,
- (b) Calculate the probability that a random person will have Flu. **(5)**
- (c) Calculate the probability that a random person with Runny Nose will have Flu. **(8)**
- (d) Calculate the probability that a random nonsmoker and nonallergic person with Runny Nose will have Flu. **(10)**

Contd P/3

CSE 473

7. (a) Given a training observation sequences of an event as $O = \{o_1, o_2, \dots, o_k\}$, formulate an *expectation maximization* (EM) algorithm to determine the parameters of a *hidden Markov model* (HMM) that best fits the training data. Assume suitable structures of the HMM, e.g., the number of hidden and visible states. **(15)**
- (b) Assume that we have two coins C_1 and C_2 each with two possible observations **(10+2)**
'Head' and 'Tail'
'Head' observation probability for C_1 is 0.6 and for C_2 is 0.4
Transition probability from C_1 to C_1 is 0.3 and from C_2 to C_2 is 0.8
Initial probability of selecting coin C_1 is 0.4 and coin C_2 is 0.6
Calculate the probability of the sequence of observations {'Tail', 'Head', 'Head'}. Which fundamental problem of HMM is this?
- (c) Mention two proximity measures between vectors along with their equations. **(8)**
8. (a) Give examples of three kinds of clusters which can cause problem to K-means clustering algorithm. **(9)**
- (b) Discuss different measures of inter-cluster similarity in the context of hierarchical clustering. **(10)**
- (c) What is a core point, noise point and border point with respect to DBSCAN clustering algorithm? **(6)**
- (d) Outline DBSCAN algorithm. When doesn't DBSCAN work well? **(6+4)**
-