

SECTION – A

There are **FOUR** questions in this section. Answer any **THREE**.

All symbols have their usual meanings.

1. (a) Design a four bit Register using D Flip-Flops and four to one Multiplexer with mode selection inputs S_1 and S_0 . The register operates according to the following function table. (15)

S_1	S_0	Register operation
0	0	No change
0	1	Complement the four outputs
1	0	Clear Register to 0 (synchronous with the clock)
1	1	Shift Right

- (b) The contents of a four-bit Register are initially 1101. The register is shifted six times to the right, with the serial input being 110101. What are the contents of the register after each shift? (10)

- (c) Design a modulo-12 up-counter with synchronous reset and also write verilog code that represents modulo-12 up counter with synchronous reset. (10)

2. (a) Design combinational circuit that generate the 9's complement and 10's complement of a BCD digit. Also write down the verilog code for the circuit. (10)

- (b) Show that a carry-out signal, C_k from bit position $k-1$ of an adder circuit can be generated as $C_k = X_k \oplus Y_k \oplus S_k$, where X_k and Y_k are inputs and S_k is the sum bit. Verify the correctness of the above expression. (10)

- (c) Design a four-bit adder with carry lookahead scheme. Also write the logic function and logic diagram of carry lookahead generator for a four-bit adder. (15)

3. (a) The priority levels of four inputs of a 4 to 2 priority encoder is given by $w_2 > w_3 > w_1 > w_0$. Using truth table and logic equations design the logic circuit for priority encoder. (10)

- (b) Given a 200-MHz clock signal, derive a circuit using D Flip-Flops to generate 100 MHz and 25 MHz clock signals. Draw a timing diagram for all clock signals, assuming reasonable delays. Write down the verilog code for positive edge triggered D Flip-Flop. (12)

- (c) Show how a JK Flip-Flop can be constructed using a T Flip-Flop and other logic gates. Write verilog code that represents a JK Flip-Flop. Use behavioral code. (6)

- (d) Design a circuit to determine how many of the bits in an eight bit unsigned number by using adder circuits. (7)

EEE 303

4. (a) Derive the dynamic power consumed in a CMOS circuit. For a CMOS inverter assume that the load capacitance is $C = 150 \text{ fF}$ and $V_{DD} = 5 \text{ V}$. The inverter is cycled through the low and high voltage levels at an average rate of $f = 75 \text{ MHz}$. (i) calculate the dynamic power dissipated in the inverter. (ii) For a chip that contains the equivalent of 250×10^3 inverters, calculate the total dynamic power dissipated if 20% of the gates change values at any given time. (9)
- (b) With a suitable example explain the terms V_{IL} , V_{IH} , V_{OL} , V_{OH} , NM_L and NM_H . (6)
- (c) Design a 4×1 Mux using a decoder and tri-state buffers. (7)
- (d) Design a logic circuit to implement a four bit magnitude comparator having one output that goes high when a four bit number (A) is greater than a four bit number (B). (13)

SECTION-B

There are **FOUR** questions in this section. Answer any **THREE**.

If any question has missing data, make an assumption and state it in your solution.

5. (a) A digital network that controls an industrial system works with three input variables: x , y , and z . The network needs to determine the existence of three separate conditions which are described below. (18)
- (i) The first condition is true if z is true and either x is true or y is false
- (ii) The second condition is true if x is true and either y or z is false
- (iii) The third condition is true if y is true and either x is true or z is false

With the help of Boolean algebra, design the simplest circuit for the network that would produce an output of 1 if at least two of the three conditions are true. Write the Verilog code to implement the circuit using the continuous assignment.

- (b) Design the simplest circuit that implements the function $f(x_1, x_2, x_3) = \sum m(1,3,4,6,7)$. Also, draw the gate level diagram of this network which is optimized in terms of speed performance. (17)
6. (a) Use at least two different methods to determine whether or not the following expression is valid, i.e., whether the left- and right-hand sides represent the same function. (17)

$$\overline{x_1} \overline{x_3} + x_2 x_3 + x_1 \overline{x_2} = \overline{x_1} x_2 + x_1 x_3 + \overline{x_2} \overline{x_3}$$

- (b) A circuit with two outputs has to implement the following functions: (18)

$$f_1(x_1, x_2, x_3, x_4) = \sum m(0,2,4,6,7,9) + D(10,11)$$

$$f_2(x_1, x_2, x_3, x_4) = \sum m(2,4,9,10,15) + D(0,13,14)$$

Design the minimum-cost circuit and compare its cost with combined costs of two circuits that implement f_1 and f_2 separately. Assume that the input variables are available in both uncomplemented and complemented forms.

EEE 303

7. (a) Find the minimum-cost form for the function $f(a,b,c,d,e) = \sum m(1,4,6,7,9,10,12,15,17,19,20,23,25,26,27,28,30,31) + D(8,16,21,22)$. Give an estimation of its cost. Assume that the input variables are available in both uncomplemented and complemented forms. (18)

(b) Draw a CMOS complex gate for the logic function $f(a,b,c,d) = \sum m(0,1,2,4,6,8,10,12,14)$. Use as few transistors as possible and show how you have derived the gate. (17)

8. (a) Write the truth table for the CMOS circuit which is shown in the following figure. Derive the simplest sum-of-products expression for the function represented by this truth table. How many transistors are needed to build the sum-of-products circuit using CMOS AND, OR and NOT gates? (18)

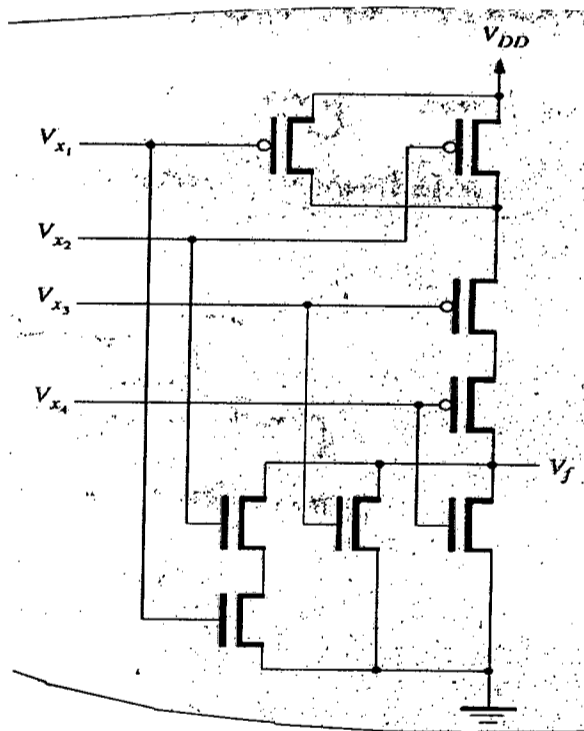

Fig. for Q. 8(a)

(b) Draw a picture of a section of a programmed FPGA which implements the core functions $f_1(x_1, x_2, x_3) = \sum m(1,2,4,7)$ and $f_2(x_1, x_2, x_3) = \sum m(0,3,5,6)$. The FPGA should have necessary inputs and the following outputs: f_1 , f_2 and $f_3 = f_1 \text{ XOR } f_2$. (17)

The figures in the margin indicate full marks.

All symbols have their usual meanings.

USE SEPARATE SCRIPTS FOR EACH SECTION

SECTION – A

There are **FOUR** questions in this section. Answer any **THREE**.

1. (a) Is the signal $x(t) = \left[\cos\left(2t - \frac{\pi}{3}\right) \right]^2$ periodic? If so, find its period. (5)

- (b) Determine whether the signal $t^2 \sin\left(\frac{2\pi}{3}t\right)$ is power or energy signal. Justify your answer. (10)
- (c) Draw $x(-2t + 5)$ for the $x(t)$ given in Fig. for Q. No. 1(c). (10)
- (d) Given $x(t) = u(t + 5) - 2u(t + 1) + 2u(t - 1) - 4u(t - 4) + u(t - 7)$. Compute $y(t) = \int_{-\infty}^t x(\tau) d\tau$ and draw. (10)

2. (a) Determine $h(t)$ for the system shown in Fig. for Q. No. 2(a). Assume $\frac{R}{L} = 1$ and $\frac{1}{LC} = 4$. (17)
- (b) Determine whether the system in Fig. for Q. No. 2(b) is BIBO stable. (18)

3. (a) Graphically determine the convolution of the pairs of signals shown in Fig. for Q. No. 3(a). (17)
- (b) A linear time-invariant (LTI) system is described by the following input-output relation: $y''(t) + 7y'(t) - 12y(t) = x''(t) + 3x'(t) + 4x(t)$
 - (i) Draw the simulation diagram of the system in second canonical form.
 - (ii) Write the state equations of the system.
 - (iii) Find the state-transition matrix of the system using Cayley-Hamilton theorem. Also, write the expression of $h(t)$ for the system. (18)

4. (a) Find the exponential Fourier-series representation of the signal shown in Fig. for Q. No. 4(a). Also, plot the magnitude and phase spectrum. (18)

EEE 301
Contd ... Q. No. 4

- (b) Show that the total average power of periodic signal $x(t)$ is the sum of the average power in each harmonic component. (17)

SECTION - B

There are **FOUR** questions in this section. Answer any **THREE**.

5. (a) Using Parseval's theorem, find the energy of the following signal: (15)

$$x(t) = \sin^2\left(\frac{t}{4}\right)$$

- (b) In Fig. for Q. 5(b), the signal $x(t)$ is multiplied by a train of rectangular pulses, $p(t)$. (20)

- (i) Find and sketch the frequency spectrum of $p(t)$.
(ii) Sketch the frequency spectrum of $x_s(t)$.
(iii) Design a system $h(t)$ to recover $x(t)$ from $x_s(t)$.

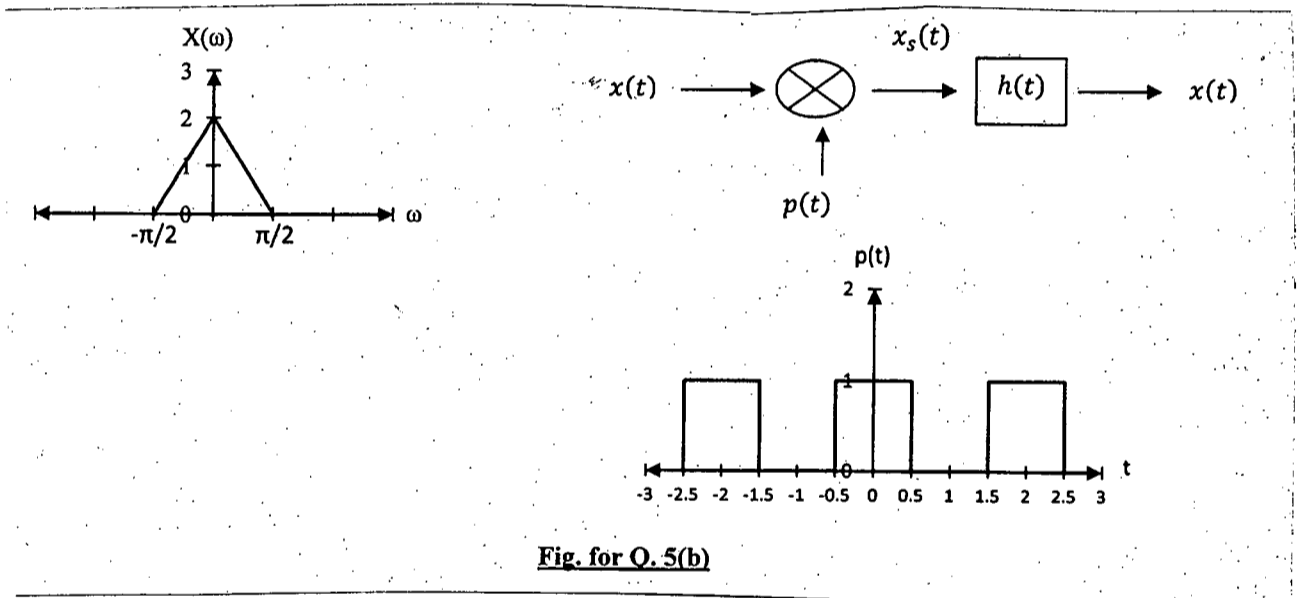

Fig. for Q. 5(b)

6. (a) A voltage signal $v(t) = e^{-2t}u(t)$ is applied to a filter, which has the frequency response (15)

$$H(\omega) = \begin{cases} 1, & |\omega| < \omega_B \\ 0, & \text{elsewhere} \end{cases}$$

- (i) Find the value of ω_B for which the filter passes exactly 50% of the energy of the input signal.
(ii) Find the impulse response of this filter. Is it practically realizable or not? Explain your answer.

- (b) For the system shown in Fig. for Q. 6(b), $R = 100 \text{ k}\Omega$ and $C = 0.1 \text{ }\mu\text{F}$. Determine the transfer function and hence sketch the plot of magnitude spectrum and phase spectrum. If $x(t) = \cos 50t - \sin 100t + \cos 200t$, determine the expression of $y(t)$. (20)

EEE 301

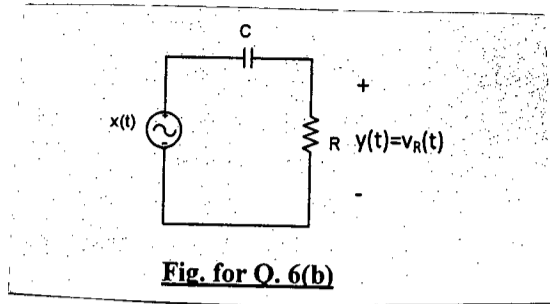

7. (a) Find the unilateral Laplace transform of the following functions and specify ROC in each case. (10)

(i) $tx(t-1) + \frac{d}{dt}x(t)$

(ii) $\int_0^t x(\tau) d\tau$

Consider, $x(t) = e^{-3t}u(t)$

(b) Find the bilateral Laplace transform of the following functions and specify ROC in each case. (10)

(i) $x_1(t) = -3e^{-2t}u(t) + 4e^t u(-t)$

(ii) $x_2(t) = e^{j2\pi t}$

(c) Step response of LTI system is given as $(1 - e^{-2t})u(t)$. (15)

Determine the response of the system when it is energized with a unit ramp signal.

8. (a) The system shown in Fig. for Q. 8(a) represents an automatic position control system. Find the final value of the system for each case and comment on the capability of position tracking and stability of the system. (15)

(i) $H_c(s) = \frac{s+1}{s}$

(ii) $H_c(s) = \frac{s+1}{s+3}$

(iii) $H_c(s) = \frac{s+1}{s-2}$

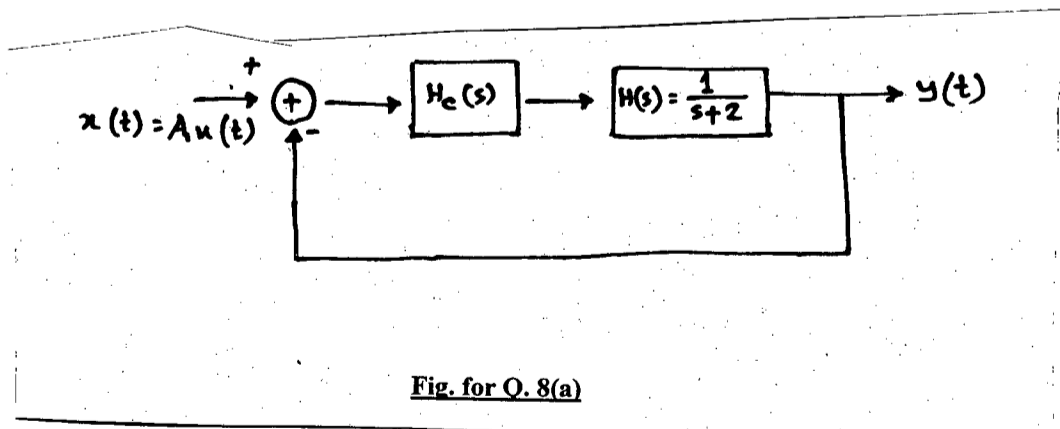

(b) A continuous time LTI system in s-domain is shown in Fig. for Q. 8(b). Specify the differential equation that characterizes the system. Determine $y(t)$ when $x(t) = 2 \cos 4t u(t)$.

Use unilateral Laplace transform method and consider zero initial energy at $t = 0$. (15)

EEE 301

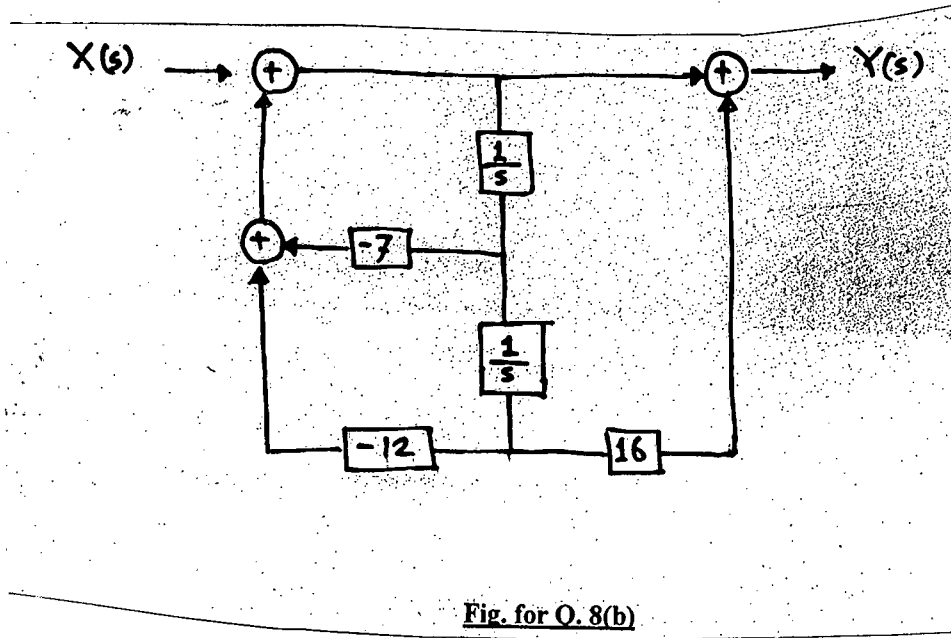

(c) For the system shown in Fig. for Q. 8(c) draw the analogous electrical circuit considering suitable analogy.

(5)

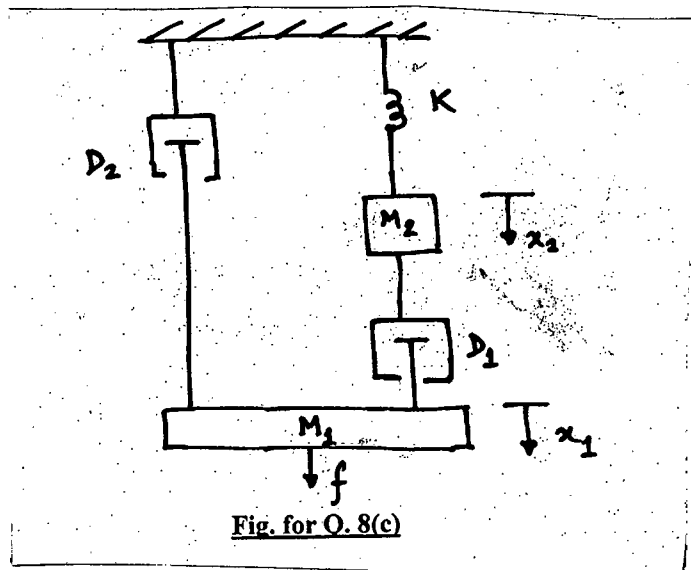

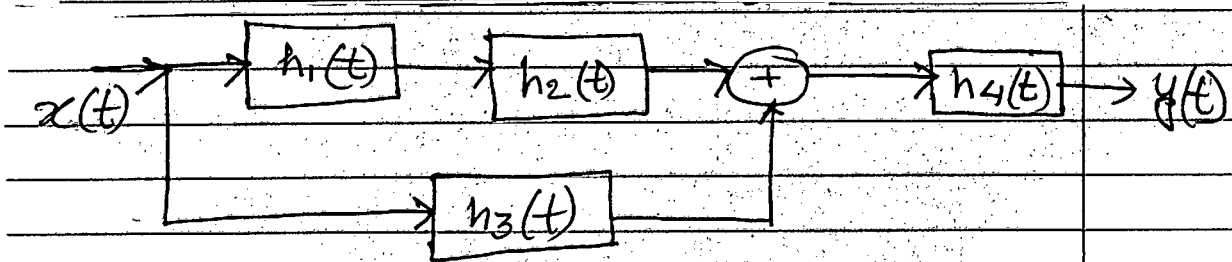
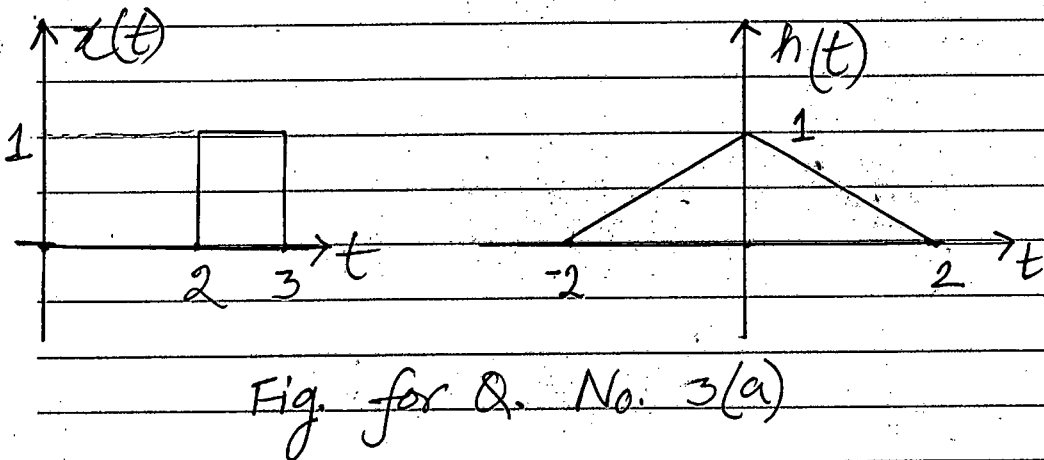
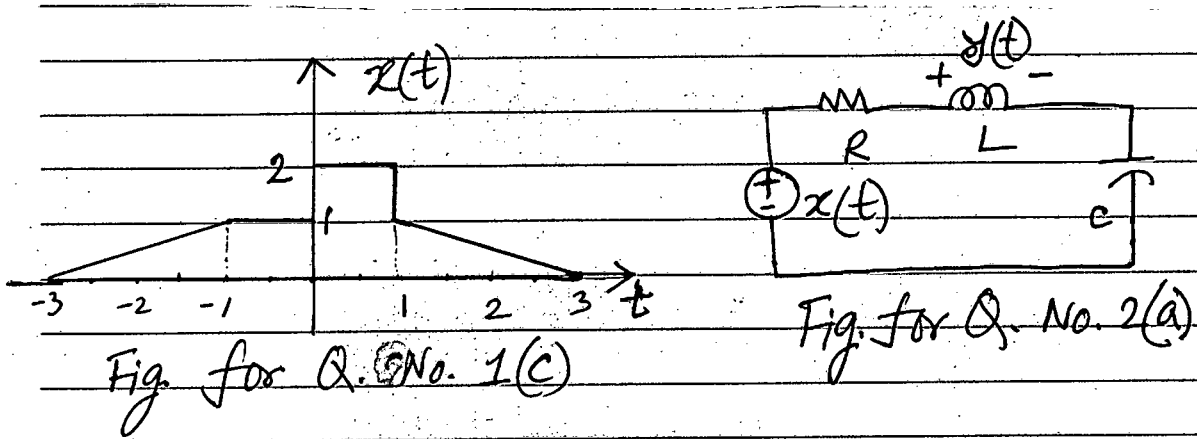

$$h_1(t) = e^{-3t} u(t)$$

$$h_2(t) = e^{-t} u(t)$$

$$h_3(t) = \delta(t-2)$$

$$h_4(t) = e^{-2t} u(t)$$

Fig. for Q. No. 2(b)

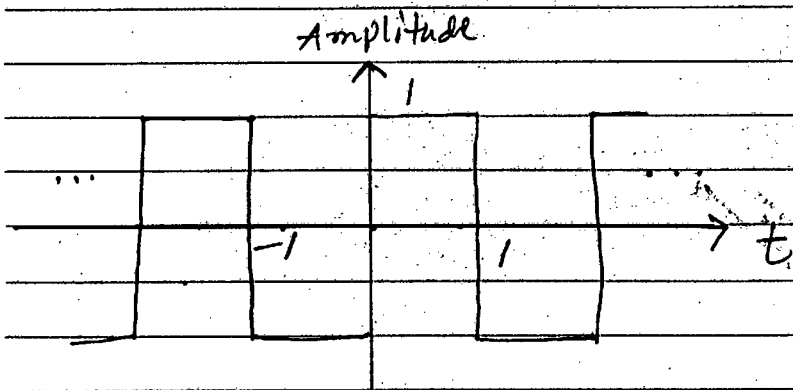

Fig. for Q. No. 4(a)

BANGLADESH UNIVERSITY OF ENGINEERING AND TECHNOLOGY, DHAKA

L-3/T-1 B. Sc. Engineering Examinations 2016-2017

Sub : **EEE 307** (Electrical Properties of Materials)

Full Marks: 210

Time : 3 Hours

USE SEPARATE SCRIPTS FOR EACH SECTION

The figures in the margin indicate full marks.

SECTION – AThere are **FOUR** questions in this section. Answer any **THREE**.

Symbols have their usual meanings.

1. (a) Dielectric properties of some materials are compared in the following table. (15)

	ϵ_r'	$\tan\delta$	E_{br}	d	C_{vol}	R_p
Polyester:	3.3	4×10^{-3}	100-300	1	30	40
Tantalum:	27	0.01	300-600	0.1	2.4×10^4	16
			[kV/mm]	[μm]	[$\mu\text{F}/\text{cm}^3$]	[k Ω]

Compare the two materials in terms of polarization mechanism, loss, breakdown and possible applications.

- (b) Discuss, in detail, the inherent properties of dielectrics that make them different from metal or semiconductors. (13)

- (c) In reproduction of documents in a Xerox machine, a thin layer of dielectrics are used. Explain the process in which that layer of As, Se and Te becomes photoconductive and assists the reproduction. (7)

2. (a) Calculate the permanent dipole moment p_o of a water molecule assuming α_e and α_d give rise to dielectric const. Use the simple relationship and Clausius-Mossotti equation to calculate p_o and comment on the difference (if any). What is ϵ_r ? [Given: p_o (theoretical) of water = 6.1×10^{-30} c.m.; $\epsilon_{r, \text{water}} = 80$; high-frequency component of ϵ_r of water = 4; density of water = $1 \text{ g}/\text{cm}^3$; mol. mass of water = $18 \times 10^{-3} \text{ kg}/\text{mol}$ and assume any other parameter that is necessary.] (20)

- (b) We know that the local field inside a material is increased above its value in free space due to the presence of dipoles. Using this fact, derive the Lorentz relation for the local field (E_{loc}) in terms of polarization (P). (15)

3. (a) Rochelle salt and quartz (SiO_2) are well-known piezoelectric materials having d (m/v) and k as 2.3×10^{-12} , 350×10^{-12} and 0.1, 0.78 respectively. Can you explain why do they have such different characteristics and what might that imply in their possible applications? (10)

- (b) In the following table, some soft magnetic materials' properties are compared to that of the 'ideal soft'. Make your comments on the possible applications of such materials. (12)

EEE 307

Contd... Q. No. 3(b)

Table for Q. 3(b)				
Soft magnetic materials	W_n	$\mu_0 H_c(T)$	$B_{sat}(T)$	$B_r(T)$
Ideal soft	0	0	large	0
Commercial iron	250	$< 10^{-4}$	2.2	< 0.1
78 Permalloy	< 0.1	5×10^{-6}	0.86	< 0.1
Ferrites	< 0.01	10^{-5}	0.4	< 0.01

- (c) Describe some applications of photonic band material. Explain how sub-surface imaging is possible using a super lens. (13)
4. (a) Describe how the technological developments in vacuum dynamics and the developments of the science of gas thermodynamics helped H. Onnes achieve He liquefaction and thereby discover superconductivity almost by accident. (15)
- (b) Explain the properties of paramagnetic, ferromagnetic, and ferrimagnetic materials in terms of domains and describe some of their applications. (13)
- (c) What is exchange interaction? (7)

SECTION-B

There are **FOUR** questions in this section. Answer any **THREE** questions.

5. (a) Molybdenum has the BCC crystal structure with a density of 10.22 g cm^{-3} and an atomic mass of 95.94 g mol^{-1} . What are the atomic concentration, lattice parameter, and atomic radius of molybdenum? (10)
- (b) Niobium has the BCC crystal structure with a lattice parameter $a = 0.3294 \text{ nm}$. Find the planar concentrations as the number of atoms per nm^2 of the (1 1 0) and (1 1 1) planes. (10)
- (c) What does a family of crystallographic directions signify? How is it defined? Draw the following: (i) $[\bar{2} 1 0]$ and (ii) $[0 1 1]$ (15)
6. (a) For an isomorphous alloy $A\%-B\%$ ($B\%$ solute in $A\%$ solvent), show that the temperature coefficient of resistivity α_{AB} can be expressed as $\alpha_{AB} \approx \frac{\alpha_A \rho_A}{\rho_{AB}}$, where ρ_{AB} is the resistivity of the alloy (AB) and ρ_A and α_A are the resistivity and TCR of pure A , respectively. Specify the assumptions behind this relation. (10)

EEE 307

Contd... Q. No. 6

(b) Estimate the composition of the Cu-Ni alloy that will have a TCR of $4 \times 10^{-4} \text{ K}^{-1}$.
 (Given, $\rho_{Cu} = 17.1 \text{ n}\Omega\text{-m}$, $\alpha_{Cu} = 4 \times 10^{-3} \text{ K}^{-1}$ and the Nordheim coefficient of Ni dissolved in Cu is $C = 1570 \text{ n}\Omega\text{-m}$).

(10)

(c) Consider the rectangular sample, a metal, shown in Fig. for Q. 6(c). A current I passes along L , perpendicular to the cross-sectional area WD . The face $W \times L$ is exposed to a magnetic field density B . A voltmeter is connected across the width to read the Hall voltage V_H .

(15)

Show that $V_H = \frac{IB}{Den}$.

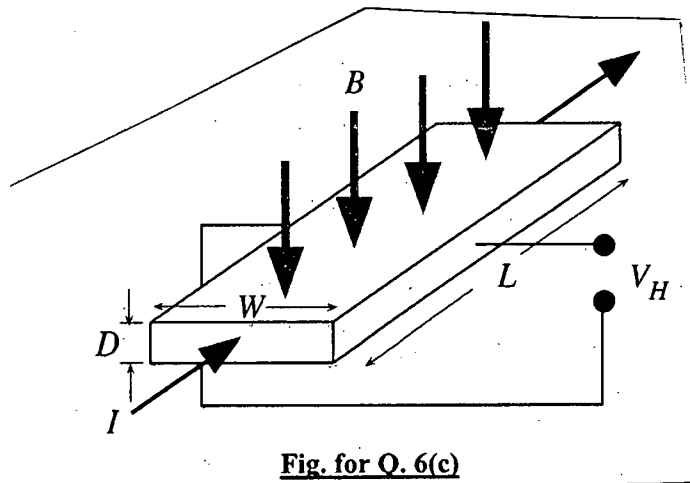

7. (a) Find the expressions of wavefunctions and energies for an electron confined in a 2D infinite potential well. What are the implications of these energies and wavefunctions?

(20)

(b) State Heisenberg's Uncertainty principle. Using de-Broglie relation, justify the Heisenberg's Uncertainty principle.

(15)

8. (a) Define electronic band structure, conduction band and valence band. Using Kornig-Penney model, briefly explain how the discrete energy levels of individual atoms form energy bands in a crystal.

(20)

(b) Derive an expression for the 2D density of states (DOS) in a semiconductor using parabolic-band approximation.

(15)

SECTION - AThere are **FOUR** questions in this Section. Answer any **THREE**.

1. (a) Derive the expression for voltage and current in terms of sending end voltage and current in a long transmission line. (15)
- (b) Show that for a long lossless transmission line terminated at a load equal to the characteristic impedance of the line, natural reactive power balance occurs. (8)
- (c) A three-phase transmission line is 300 mile long and serves a load of 400 MVA, 0.8 lagging power factor at 345 kV. The ABCD constants of the line are (12)
- $A = D = 0.818 \angle 1.3^\circ$
- $B = 172.2 \angle 84.2^\circ \Omega$
- $C = 0.001933 \angle 90.4^\circ \text{S}$
- (i) Determine the sending-end line-to-neutral voltage, the sending-end current and the percent voltage drop at full load.
- (ii) Determine the receiving-end line-to-neutral voltage at no load, the sending end current at no load and the voltage regulation.
2. (a) Explain how tap changing and regulating transformers can control flow of power in a transmission line. (12)
- (b) Consider the regulating transformer shown in figure below. The tap is on the side of node i so that the transformation ratio is $t : 1$. Find elements of the Y_{bus} and draw the equivalent π representation. (15)

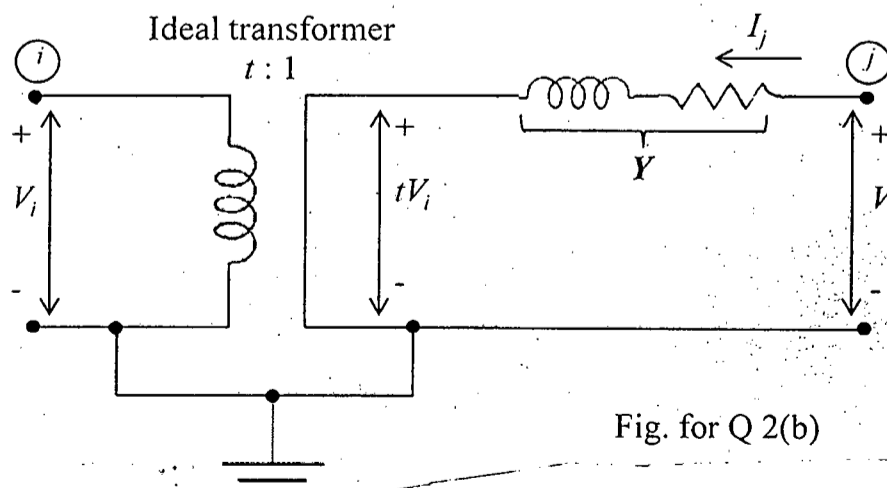

EEE 305

Contd ... Q. No. 2

- (c) Briefly explain how the Y_{bus} is modified when a regulating transformer is introduced between two buses. (8)
3. (a) Derive an expression for the current into a LLG fault occurring at bus-k through a fault impedance Z_f . Show that for $Z_f = \infty$, the current equations revert back to those for the line to line fault. (20)
- (b) The reactance of a generator rated 100 MVA 20 kV, are $X_d'' = X_1 = X_2 = 20\%$ and $X_0 = 5\%$. The generator is connected to a Δ -Y transformer rated 100 MVA, 20 Δ -230 Y kV, with a reactance of 10%. The neutral of the transformer is solidly grounded. The terminal voltage of the generator is 20 kV when a single line-to-ground fault occurs on the open-circuited, high-voltage side of the transformer. Find the initial symmetrical rms current in all phases of the generator. (15)
4. (a) With necessary diagrams explain the biased differential protection scheme for unit protection. (9)
- (b) Draw and explain the typical current and voltage wave shapes in a circuit breaker during fault clearing. (6)
- (c) Explain why a circuit breaker can deal with a higher short circuit MVA in an underground cable than in an overhead transmission line. (6)
- (d) With necessary derivation show that circuit with high natural frequency give a high rate of rise of TRV. (8)
- (e) Define "selectivity" in relation to protective relaying. Name some of the relay actuating quantities in a power system. (6)

SECTION – B

There are **FOUR** questions in this Section. Answer any **THREE** questions.

Assume any data if necessary. Symbols have their usual meanings unless stated otherwise.

5. The one-line diagram of a simple power system is shown in Fig. for Q. No. 5. Base values for the transmission system are 100 MVA, 230 kV. The line data of Table 1 give per-unit series impedances and shunt admittances for the nominal π equivalents of the four lines identified by the buses at which they terminate. The bus data in Table 2 list values for P and Q at each bus.

EEE 305

Contd ... Q. No. 5

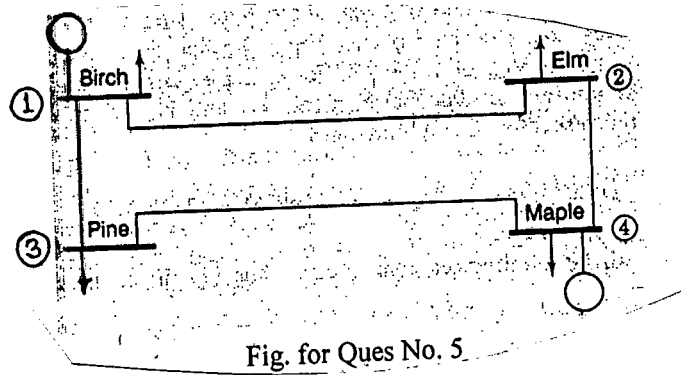

Fig. for Ques No. 5

Table 1: Line data

Line, bus to bus	Series $Y = Z^{-1}$		Shunt
	G per unit	B per unit	$Y/2$ per unit
1-2	3.8156	-19.0781	0.0513
1-3	5.1696	-25.8478	0.0388
2-4	5.1696	-25.8478	0.0388
3-4	3.0237	-15.1185	0.0638

Table 2: Bus data

Bus	Generation		Load		Remarks
	P , MW	Q , Mvar	P , MW	Q , Mvar	
1	-	-	50	30.99	Slack bus
2	0	0	170	105.35	Load bus
3	0	0	200	123.94	Load bus
4	318	-	80	49.58	Voltage controlled

(i) Identify the state variables of the power-flow problem. Using the decoupled form of the Newton-Raphson method and flat-start estimates, determine the value of the state variables after the first iteration. (23)

(ii) Suppose power-flow solution (after convergence) for the system is given in Table 3. (12)

Table 3: Power-flow solution

Bus no.	Volts (p.u.)	Angle (deg.)
1	1.000	0
2	0.982	-0.976
3	0.969	-1.872
4	1.020	1.523

Draw a single-line diagram showing flow of megawatts and megavars in the line connecting buses 1 and 3, and determine the I^2R loss of the line.

= 4 =

EEE 305

6. (a) Starting with the power-flow equations

(7)

$$P_i = \sum_{n=1}^N |Y_{in} V_i V_n| \cos(\theta_{in} + \delta_n - \delta_i)$$

$$Q_i = - \sum_{n=1}^N |Y_{in} V_i V_n| \sin(\theta_{in} + \delta_n - \delta_i)$$

show that

$$|V_j| \frac{\partial Q_i}{\partial |V_j|} = \frac{\partial P_i}{\partial \delta_j}$$

Where the symbols have their usual meanings.

(b) A new housing development is to be added to the lines of a public utility. There are 1000 apartments, each having a connected load of 4 kw. Stores and services are also included of the characteristics shown in the following tabulation:

(16)

Store or service	Connected kw	Demand factor, per cent
1 laundry	20	68
2 churches	10 each	56
1 restaurant	60	52
1 bookstore	5	66
1 dry-goods store	7	76
2 drugstores	10 each	79
2 grocery stores	5 each	73
1 shoe store	2	67
1 clothing store	4	53
1 theater	100	49

The demand factor of the apartments is 45 percent. The group diversity factor of the residential load for this system is 3.5, and the peak diversity factor is 1.4. The commercial-load group diversity 1.5, and the peak diversity factor is 1.1. Find the increase in peak demand on the total system delivery from the station bus resulting from addition of this development on the distribution system.

(c) The yearly load duration curve of a generation system is shown in Fig. for Q. No. 6 (c). What is the minimum load on the system? A standby unit of 8 MW capacity carries all the incremental loads above 24 MW. What is the load factor, capacity factor and utilization factor of the standby unit? The load duration curve is linear between point a and point b.

(12)

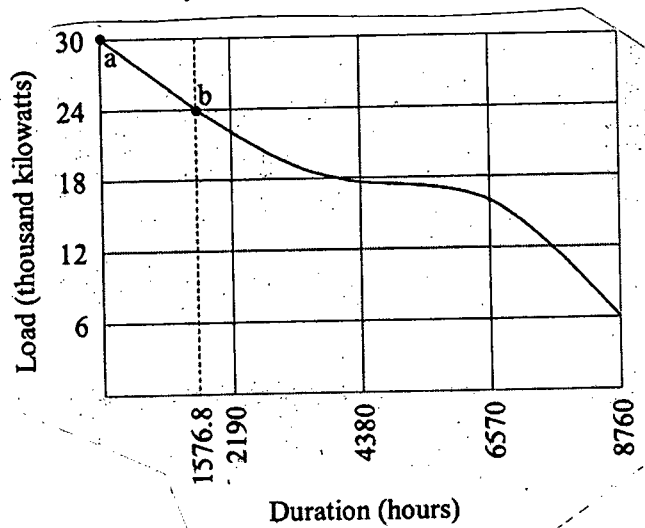
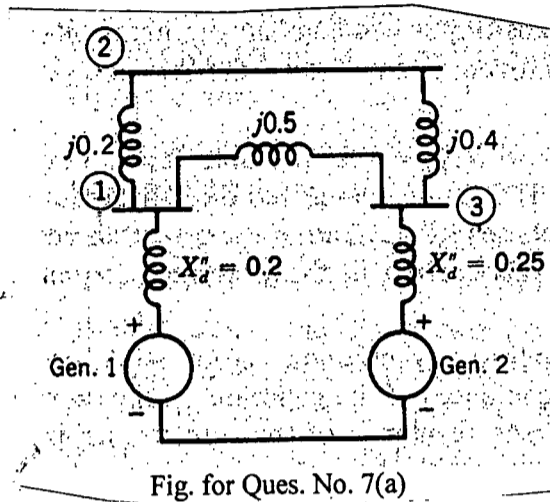

Fig. for Ques No. 6(c)

Contd P/5

EEE 305

7. (a) For the network shown in Fig. for Q. No. 7(a), find the subtransient currents in per unit from generator 1 and in line 1-2 for a three-phase fault on bus 2. Assume that no current is flowing prior to the fault and that the prefault voltage at bus 2 is $1\angle 0^\circ$ per unit. (20)



- (b) Show that the Thevenin impedance at a representative bus k of a network is equal to Z_{kk} , where Z_{kk} is the diagonal entry in row k and column k of the bus impedance matrix of the network. (15)
8. (a) Draw the zero-sequence network with letters to indicate points corresponding to the single-line diagram shown in Fig. for Q. No. 8(a). (12)

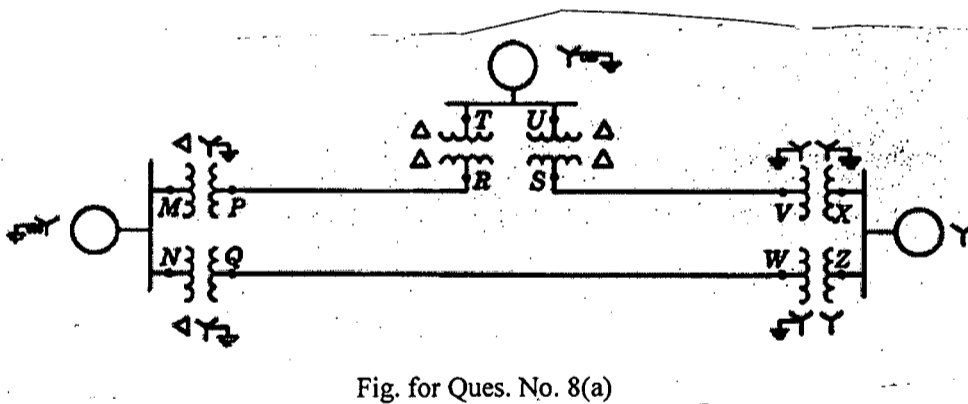

- (b) Derive the expression of power expended in a three-phase circuit in terms of the symmetrical components of currents and voltages. (12)
- (c) Balanced three-phase voltages of 100 V line to line are applied to a Y-connected load consisting of three resistors. The neutral n of the load is not grounded. The resistance in phase a is $10\ \Omega$, in phase b is $20\ \Omega$ and in phase c is $30\ \Omega$. Determine the current in phase a and the voltage V_{an} . (11)

BANGLADESH UNIVERSITY OF ENGINEERING AND TECHNOLOGY, DHAKA

L-3/T-1 B. Sc. Engineering Examinations 2016-2017

Sub : **HUM 279** (Financial and Management Accounting)

Full Marks : 210

Time : 3 Hours

The figures in the margin indicate full marks.

USE SEPARATE SCRIPTS FOR EACH SECTION

SECTION – A

There are **FOUR** questions in this Section. Answer any **THREE**.

1. (a) What are the different types of financial statements that are usually published in the annual report? (5)
- (b) Write down the elements of comprehensive income. (4)
- (c) Rosy Pervez is a licensed architect. During the first month of the operation of her time, the following transactions occurred: (26)
- May 1: Started her firm investing Tk. 600,000 cash and equipment Tk. 90,000.
- May 3: Paid office rent in advance Tk. 10,000 cash for two months.
- May 5: Service rendered and earned Tk. 50,000 but not yet received.
- May 8: Purchased office supplies for cash Tk. 20,000.
- May 11: Purchased a car for office purpose for Tk. 100,000. Paid cash Tk. 30,000 and signed a notes payable for Tk. 70,000.
- May: 15: Cash received Tk. 10,500 for service of May 5.
- May 16: Paid to notes payable Tk. 20,000 in cash.
- May 21: Withdrew Tk. 5,000 cash from the business for personal use.
- May 25: Paid electricity bill for the month of May in cash Tk. 15,000.
- May 28: Paid insurance premium for the month of May in cash Tk. 8,000.
- Required:**
- (i) Prepare a tabular summary for the month of May.
- (ii) Prepare an income Statement for the month of May 2016.
2. (a) Distinguish between journal and ledger. (5)
- (b) Mr. Mamun started a business on February 1, 2015. The following transactions took place during the month – (20)
- February 1: Owner invested Tk. 800,000 cash in the business.
- February 2: Service provided to a customer but not yet received Tk. 60,000.
- February 3: Cash received from customers Tk. 25,000 but services will be provided in May.
- February 7: Paid the monthly salary of the two employees, totaling Tk. 20,000 in cash.
- February 10: Incurred utility expenses for the month on account Tk. 2,000.
- February 11: Made an additional investment by Mr. Mamun for Tk. 400,000 in cash.

HUM 279 (EEE)

Contd ... Q. No. 2(b)

February 13: Received Tk. 10,000 in cash from the customer by providing services.

February 22: Paid telephone bill for the month Tk. 5,000 in cash.

February 25: Paid Tk. 15,000 to account payable in cash.

February 25: Received Tk. 50,000 in cash from customers in payment of accounts receivables.

Required:

(i) Give journal entries for the month of February, 2015

(c)

Villa Tool Company Income statement For the year ended December 31, 2015	
Particular	Amount(Tk.)
Net sales	1,818,500
Cost of goods sold	1,011,500
Gross profit	807,000
Selling and administrative expense	516,000
Income from operations	291,000
Interest expense	18,000
Income before income tax	273,000
Income tax expense	81,000
Net income	192,000

Villa Tool Company Balance Sheet December 31, 2015	
Particular	Amount(Tk.)
Assets:	
Current Asset	
Cash	60,100
Short term investment	69,000
Accounts receivable	117,800
Inventory	123,000
Total Current Asset	369,900
Plant asset	600,300
Total assets	970,200
Liabilities and stockholders' equity	
Current Liability	
Accounts payable	160,000
Income tax payable	43,500
Total current liabilities	203,500
Bonds payable	200,000
Total liabilities	403,500
Stockholders' equity	
Common stock (Tk.5 par)	280,000
Retained earnings	286,700
Total stockholders' equity	566,200
Total liabilities and stockholders' equity	970,200

HUM 279 (EEE)

Contd ... Q. No. 2(c)

Required: Calculate

- (i) Quick or acid test ratio.
- (ii) Current ratio
- (iii) Return on equity (ROE).
- (iv) Earnings per share (EPS).
- (v) Inventory turnover.

3. (a) What are the basic reasons of recording adjusting entries? Explain. (5)

(b) The Trial Balance of "Navana Builders" at May 31, 2014 is given below: (30)

"Navana Builders"			
Trial Balance			
May 31, 2014			
	Accounts Title	Debit (TK.)	Credit(Tk.)
	Cash	15,000	
	Accounts receivable	7,000	
	Prepaid insurance	2,400	
	Supplies	1,500	
	Office furniture	15,000	
	Accounts payable		5,500
	Unearned service revenue		6,000
	Capital		27,500
	Service revenue		7,900
	Salary expense	2,000	
	Rent expense	1,000	
	Maintenance expense	2,000	
	Drawings	1,000	
	Total	46,900	46,900

Other Information:

- Supplies on hand Tk. 1000.
- Maintenance expense incurred but not paid on May 31, Tk. 8000.
- Tk. 3,000 of service performed during the month but has not been recorded as of May 31.
- Insurance policy is for two years.
- Interest accrued at May 31 is Tk. 1000.
- Office equipment is being depreciated at Tk. 250 per month.
- Accrued salary is Tk. 1000.

Required:

- (i) Prepare necessary adjusting entries.
- (ii) Prepare an adjusted trial balance as at May 31, 2014.

4. (a) Define current liability. What basis is used for arranging individual items within the current liability section? (5)

(b) The trail balance of "Solar Power Company" is given below- (30)

HUM 279 (EEE)

Contd ... Q. No. 4(b)

“ Green Power Company”
Trial Balance
31st December, 2015

Accounts Title	Debit (Tk.)	Credit (Tk.)
Cash	40,500	
Accounts receivable	15,000	
Accounts payable		12,000
Mortgage payable		3,700
Merchandise inventory (01.01.2015)	5,800	
Purchase	20,100	
Sales		40,500
Sales returns	1,200	
Purchase discount		500
Capital		46,200
Drawings	2,300	
Salaries	3,400	
Prepaid insurance	3,600	
Machinery	16,000	
Rent expense	5,000	
Goodwill	20,000	
Bond payable		20,000
Tax payable		5,000
Unearned revenue		5,000
Total	132,900	132,900

Adjustments:

- Merchandise inventory on December 31st 2015 is Tk. 6,700.
- Rent is 40% administrative and 60% selling.

Required:

- (i) Prepare a multiple step (classified) income statement.
- (ii) Prepare a statement of owner equity.
- (iii) A classified Balance Sheet as on 31st December, 2015.

SECTION – B

There are **FOUR** questions in this Section. Answer any **THREE** questions.

5. (a) What are the three major elements of product costs in a manufacturing company? (7)
- (b) How will you differentiate between direct material and manufacturing overhead cost? (7)
- (c) Ultimately there exist no fixed cost in this world” – Do you agree with the statement?
Why or why not? (7)
- (d) Explain the difference between a product cost and a period cost. (7)
- (e) What effect does an increase in volume have on – (7)
 - Unit fixed costs?
 - Unit variable costs?
 - Total fixed costs?
 - Total variable costs?

HUM 279 (EEE)

6. (a) What are the assumptions of Cost, Volume and Profit (CVP) analysis? Do you think those assumptions are unrealistic? Why or why not? (5)

(b) Siemens Company manufactures and sells a specialized cordless telephone for high electromagnetic radiation environments. The company's contribution format income statement for the most recent year is given below: (30)

Particulars	Total(Tk.)	Per Unit(Tk.)	Percentage
Sales (20000 Unit).....	120,0000	60	100
Variable Expense.....	(900,000)	45	?
Contribution Margin(CM)...	300,000	15	?
Fixed Cost.....	(240,000)		
Net Operating Income.....	60,000		

Management is anxious to increase the company's profit and has asked for an analysis of a number of items. (7)

Required:

- (i) Compute the company's CM ratio and variable expense ratio.
- (ii) Compute the company's break-even point in both units and sales TK.
 - (a) Use the equation method
 - (b) Use shortcut method
- (iii) Assume that sales increase by Tk. 400,000 next year. If cost behavior patterns remain unchanged, by how much will the company's net operating income increase? Use the CM ratio to compute you answer.
- (iv) Refer to the original data. Assume that next year management wants the company to earn a profit of at least Tk. 90,000. How many units will have to be sold to meet this target profit?
- (v) Refer to the original data. Compute the company's margin of safety.
- (vi) Refer to the original data. Suppose the company wants to bring a new policy which will increase variable cost Tk. 5 per unit but sales unit will be increased by 5000 units as quality of product will be increased. Should this change be implemented?
- (vii) Refer to the original data. Suppose the company wants to bring a new policy which will increase fixed cost Tk. 40,000 but sales unit will be increased by 1000 units as quality of product will be increased. Should this change be implemented?
- (viii) In an effort to increase sales and profits, management is considering the use of a higher quality speaker. The higher-quality speaker would increase variable costs by Tk. 3 per unit, but management could eliminate one quality inspector who is paid a salary of Tk. 30,000 per year. The sales manager estimates that the higher-quality

HUM 279 (EEE)

Contd ... Q. No. 6(b)

speaker would increase annual sales by at least 20%. Would you recommend that the changes be made?

7. KK Moody Company provided the following account balances for the year ended 31st December, 2016.

Selling expenses	\$215,000
Purchases of raw materials	\$260,000
Direct labor	?
Administrative expenses	\$100,000
Prime Cost	\$ 350000
Manufacturing overhead	?
Total Manufacturing Cost.....	\$ 690000
Sales	\$ 1050000

Information about the inventories are as follows:

Types of Inventory	Beginning of Year	End of the Year
Raw materials	\$ 50000	?
Work in process	?	\$ 33000
Finished goods	\$ 60000	?

Raw material used/consumed was \$ 280000; Cost of Goods manufactured \$ 657000. Gross Profit for the year was \$ 350000 and the Net Operating Income was \$35,000.

Required:

Prepare schedules of cost of goods manufactured and cost of goods sold and an income statement to find out:

- (i) Ending Raw material Inventory
- (ii) Direct Labor Cost
- (iii) Manufacturing Overhead Cost
- (iv) Work In Progress Beginning
- (v) Ending Finished Goods
- (vi) Cost of Goods Sold
- (vii) Total Administrative Expense

8. (a) The administrator of Apolo Hospital would like a cost formula linking the administrative costs involved in admitting patients to the number of patients admitted during a month. The Admitting Department's costs and the number of patients admitted during the immediately preceding eight months are given in the following table:

(15)

Month	Number of Patients Admitted	Admitting Departmental Cost(Tk.)
May	1800	14,700
June	1900	15,200
July	1700	13,700
August	1600	14,000
September	1500	14,300
October	1300	13,100
November	1100	12,800
December	1550	14,600

HUM 279 (EEE)

Contd ... Q. No. 8(a)

Required:

- (i) Use the high-low method to estimate the fixed and variable components of admitting costs.
- (ii) Express the fixed and variable components of admitting costs as a cost formula in the form $Y = a + bx$.
- (b) What is capital budgeting? Write down the importance of capital budgeting decision. (5)
- (c) What are the limitations of net present value (NPV) method? (5)
- (d) Consider the projects below with respective cash flows:

Project	Years					
		1	2	3	4	5
	(Cash Out Flow)					
M	(195,000)	35,000	80,000	90,000	75,000	20,000
N	(180,000)	28,000	40,000	50,000	90,000	10,000

Required: Calculate Net Present Value (NPV) for both projects at 12% cost of capital.

(10)