

SECTION – AThere are **FOUR** questions in this Section. Answer any **THREE**.

1. (a) How did Rutherford interpret the following observations made during his alpha particle scattering experiments? **(3+3+3=9)**
- (i) Most alpha particles were not appreciably deflected as they passed through the foil.
- (ii) A few alpha particles were deflected at very large angles.
- (iii) What differences would you expect if beryllium foil were used instead of gold foil in the alpha particle scattering experiment?
- (b) (i) What is the mass in amu of carbon-12 atom? **(2+3=5)**
- (ii) Why is the atomic weight of carbon reported as 12.011 in the periodic table?
- (c) Iodic acid has the molecular formula. HIO_3 write formulas for the following. **(5×2=10)**
- (i) the iodate anion, (ii) the periodate anion (iii) the hypoiodate anion
- (iv) hypiodous acid (v) Periodic acid.
- (d) Write down four postulates of Dalton's Atomic theory. **(8)**
- (e) Write down the molecular formula, structural formula and perspective drawing of methane. **(3)**
2. (a) (i) Define the term lattice energy. Which factors govern the magnitude of the lattice energy of an ionic compound? **(5+6=11)**
- (ii) Explain the following trends in lattice energy: $\text{NaCl} > \text{RbBr} > \text{CsBr}$; $\text{BaO} > \text{KF}$; $\text{SrO} > \text{SrCl}_2$.
- (b) Define the terms (i) polar covalent bond, (ii) non-polar covalent bond and, (iii) ionic bond. Give the values of electronegativity difference for these kinds of bonds. **(3×2=6)**
- (c) The bond length in the HCl molecules is 1.27 Å. **(3+3=6)**
- (i) Calculate the dipole moment, in debyes that results if the charges on the H and Cl atoms were $1+$ and $1-$, respectively.
- (ii) The experimentally measured dipole moment of HCl(g) is 1.08 D. What magnitude of charge, in units of e^- , on the H and Cl atoms leads to this dipole moment?
- (d) (i) Write a Lewis structure of phosphorus trifluoride molecule, PF_3 . Is the octet rule satisfied for all the atoms in your structure? **(4×3=12)**
- (ii) Determine the oxidation numbers of the P and F atoms.
- (iii) Determine the formal charges of the P and F atoms.
- (iv) Is the oxidation number for the P atom as the same as its formal charge? Explain.

CHEM 115(WRE)

3. (a) A voltaic cell consists of a strip of cadmium metal in a solution of $\text{Cd}(\text{NO}_3)_2$ in one beaker, and in the other beaker a platinum electrode is immersed in a NaCl solution, with Cl_2 gas bubbled around the electrode. A salt bridge connects the two beakers. (2+3+3+3=11)
- (i) which electrode serves as the anode and which as the cathode?
- (ii) Does the Cd electrode gain or lose mass as the cell reaction proceeds?
- (iii) Write the equation for the overall cell reaction.
- (iv) What is the emf generated by the cell under standard conditions?

$$E_{red}^{\circ}(\text{Cl}_2/2\text{Cl}^-) = 1.359 \text{ V}, \quad E_{red}^{\circ}(\text{Cd}^{2+}/\text{Cd}) = -0.403 \text{ V}$$

- (b) If the equilibrium constant for a one electron redox reaction at 298 K is 8.7×10^4 , calculate the corresponding Δh° and E_{red}° . (6)

- (c) (i) A voltaic cell is constructed with all reactants and products in their standard states.

Will this condition hold as the cell operates? Explain. (3×3=9)

(ii) Can the Nernst equation be used at any temperatures other than room temperatures? Explain.

(iii) What does happen to the emf of a cell if the concentrations of the products are increased?

- (d) (i) What is the difference between a battery and fuel cell? (ii) Can the “fuel” of a fuel cell be a solid? Explain. (6)

- (e) An iron object is plated with a coating of cobalt to protect against corrosion. Does the cobalt protect iron by cathodic protection? Explain. (3)

$$E_{red}^{\circ}(\text{Co}^{2+}/\text{Co}) = -0.28 \text{ V}, \quad E_{red}^{\circ}(\text{Fe}^{2+}/\text{Fe}) = -0.44 \text{ V}$$

4. (a) Einstein’s 1905 paper on the photoelectric effect was the first important application of Planck’s quantum hypothesis. Describe Planck’s original hypothesis, and explain how Einstein made use of it in his theory of the photoelectric effect. (8)

- (b) Sodium metal requires a photon with a minimum energy of 4.4×10^{-19} J to emit electrons. (4×3=12)

(i) What is the minimum frequency of light necessary to emit electrons from sodium via the photo electric effect?

(ii) What is the wavelength of this light?

(iii) If sodium is irradiated with light of 405 nm, what is the maximum possible kinetic energy of the emitted electrons?

(iv) What is the maximum number of electrons that can be freed by a burst of light whose total energy is 1.00 μJ ?

CHEM 115(WRE)

Contd ... Q. No. 4

- (c) (i) In terms of the Bohr theory of the hydrogen atom, what process is occurring when excited hydrogen atoms emit radiant energy of certain wavelengths and only those wavelengths? (2×3=6)
- (ii) Does a hydrogen atom “expand” or “contract” as it moves from its ground state to an excited state? (9)
- (d) Draw the radial probability distributions for the 1S, 2S and 3S orbitals of hydrogen. (9)

SECTION – B

There are **FOUR** questions in this Section. Answer any **THREE** questions.

5. (a) Define Tyndall effect. Write the conditions necessary for colloidal particles to show this effect. Explain the basic principle of ultramicroscope for the quantitative estimation for the quantitative estimation of Tyndall effect. (10)
- (b) What are the reasons for colloidal particles to gain electrical charge? Explain them with suitable examples. (7)
- (c) Describe the preparation of colloid by electrical disintegration method. Why purification of colloid is needed after its preparation? Discuss the electro dialysis process of colloid purification. (10)
- (d) Explain the following: (8)
- (i) Gel and hydrogel.
- (ii) Formation of deltas at river junction
6. (a) Derive the integral form of Kirchoff's equation for the following conditions: (12)
- (i) Change of heat capacity ΔC_p is constant over the temperature range.
- (ii) ΔC_p is not constant over the temperature range.
- Mention the significance of Kirchoff's equation.
- (b) A cylindrical of LPG gas contains 13. 2 kg C_4H_{10} . A family needs 25,000 kJ energy per day for cooking. Heat of combustion of C_4H_{10} is 2658 kJmol^{-1} . Heat of combustion is 90%. Find out for how many days the family can use that gas cylinder. (5)
- (c) Define enthalpy of neutralization. Giving schematic diagram describe how the heat change of neutralization can be determined. Mention the probable sources of error in this method and write how these can be minimized. (12)
- (d) Discuss Hess's law of constant heat summation with suitable example. Write two applications of Hess's law. (6)

CHEM 115(WRE)

7. (a) Derive the expression that shows the relationship between free energy change and equilibrium constant of a reversible reaction. Write the conditions of free energy change for spontaneous, nonspontaneous process and the process at equilibrium. (10)
- (b) What is meant by dynamic equilibrium for a chemical reaction? How the dynamic nature of chemical equilibrium can be experimentally determined? (6)
- (c) Volume of water increases when it freezes. Applying Le Chatelier's principle predict the effect of pressure on the freezing point of water. (6)
- (d) (i) For the reaction, $3A(g) + B(g) \rightleftharpoons 2C(g)$ write the mathematical expression of equilibrium constant, k_c . (3+5+5=13)
- (ii) At 25°C for the above reaction $K_c = 9.0$. Can a mixture of 2.00 mole each of A, B and C exist in equilibrium in a 1.0L flask? Show by calculation.
- (iii) What must be the volume of the flask if the mixture in question d(ii) is to remain in equilibrium?
8. (a) The pH of 0.100 M HCN solution is found to be 5.2. What is the value of acid dissociation, K_a for HCN? (5)
- (b) Draw neutralization curve for the titration of weak acid with strong base. Explain different regions of this curve and comment on the choice of suitable indicator for this titration. (8)
- (c) Why does pure water possess poor electrical conductivity and high heat capacity? Explain in the light of water structure. (10)
- (d) What are amphiprotic substances? Explain with suitable examples. (5)
- (e) Define buffer system and buffer capacity? Illustrate buffer action with appropriate example. (7)
-

BANGLADESH UNIVERSITY OF ENGINEERING AND TECHNOLOGY, DHAKA.

L-1/T-1 B. Sc. Engineering Examinations 2016-2017

Sub : **HUM 111** (English)

Full Marks : 140

Time : 3 Hours

The figures in the margin indicate full marks.

USE SEPARATE SCRIPTS FOR EACH SECTION

SECTION – A

There are **FOUR** questions in this Section. Answer Q. No. 1 and any other **TWO** from the rest.

1. Read the following passage carefully and answer the questions that follow: (30)

Unquestionably a literary life is for the most part an unhappy life, because if you have genius, you must suffer the penalty of genius; and if you have only talent, there are so many cares and worries incidental to the circumstances of men of letters, as to make life exceedingly miserable. Besides, the pangs of composition and continuous disappointment which a true artist feels at his inability to reveal himself, there is the difficulty of gaining the public ear. Young writers are buoyed up by the hope and the belief that they have only to throw the poem or novel into print to be acknowledged at once as new light in literature. They are never convinced that the editors of magazines and the publishers of books are practical, who are by no means frantically anxious about placing the best literature before the publisher. Most of them are mere commercial who conduct their business on the hardest line of profit and loss account. But supposing your book was fairly launched its perils were only beginning. You have to run the gauntlet of the critics. To a young author, again this seems as an ordeal. When you are a little older, you will find that criticism is not much more serious than the play of clowns in a circus. A time comes in the life of every author when he regards critics as commercial rather than formidable. But there are sensitive souls that yield under the chastisement and, perhaps after suffering much silent torture, abandon the profession of the pen forever. But the most unwise thing in the world for an author is to take public notice of criticism in the way of defending himself. Silence is the only safe-guard as it is the only dignified protest against insult.

Questions:

- (i) How is a literary life an unhappy life?
- (ii) What is the difficulty of a young author?
- (iii) How can an author defend himself?
- (iv) "Criticism is not much more serious than the play of clowns in a circus" – Explain the idea in brief.
- (v) What is the main idea of the passage?
- (vi) Give meanings of the following words as used in the passage: Pangs, frantically, ordeal, chastisement, safe-guard.

HUM 111(WRE)

2. (a) Suppose you are the Chief Engineer of a firm. Draft a suitable complaint letter about having received damaged and defective goods from your suppliers. (Provide other details from your own). (10)
- (b) Write phonetic transcriptions of the following words: (Any five) Actual, son, care, cottage, donate, finger. (10)
3. (a) Write a dialogue between two friends about the water logging in some of the place of Dhaka city during rainy season. (10)
- (b) Write a short essay on any ONE of the following: (10)
- (i) Juvenile Delinquency: Social Cause
 - (ii) Expected Education System
 - (iii) Popular Entertainments
4. (a) Transform the following sentences as directed. (Any five): (10)
- (i) What he has said is true (Make it simple).
 - (ii) The war is over and silence prevails. (Simple).
 - (iii) Momin was very suspicious, but he tried one at last.
 - (iv) It is difficult to explain, but it exists (Simple).
 - (v) On account of his negligence the company suffered heavy losses (Compound).
 - (vi) You can't buy things unless you have money. (Compound).
- (b) Write short notes on any TWO of the following: (10)
- (i) Barriers to Communication
 - (ii) The Diphthongs
 - (iii) Components of a formal report.

SECTION – B

There are **FOUR** questions in this Section. Answer Q. No. 5 as and any **TWO** from the rest.

5. (a) Explain with reference to the context any one of the following: (8)
- (i) "All these things which another woman of her station would not have noticed tortured and angered her".
 - (ii) . "Capital punishment kills a man at once, but lifelong imprisonment kills him slowly.
- (b) Answer any one of the following: (10)
- (i) Make critical comments on the changes that came over the life of the lawyer during his imprisonment.
 - (ii) Give a character-sketch of Mrs. Matilda loisel.

HUM 111(WRE)

Contd ... Q. No. 5

- (c) Answer any three of the following: (12)
- (i) What happened in the morning on which the lawyer escaped from jail?
 - (ii) How were the feelings of Mrs. Matilda Loisel at the party given by the Minister of Public Instruction?
 - (iii) Why did her friend fail to recognize Mrs. Loisel.
 - (iv) What do you know about Laura in 'The Garden Party'?
6. Recast and correct any ten of the following sentences: (20)
- (i) The amount of horses on the range was small.
 - (ii) Somewheres there must be an answer.
 - (iii) Walt Whitman occupies a most unique place in literature.
 - (iv) I was in a dilemma about what to have for dinner.
 - (v) It was them who was to do the work.
 - (vi) Illiteracy is when a man cannot read or write.
 - (vii) He had a need and interest in athletics.
 - (viii) There was a maverick beside the bush which the cowboy lassoed.
 - (ix) The letter came prior to the package.
 - (x) He decided to work slow and easy.
 - (xi) If I were him I should not accept the post.
 - (xii) This is the case what I want.
7. (a) Give meanings of any ten of the following words: (10)
- Alleviate, brandish, cryptic, diffidence, entice, fluffy, grouchy, intricate, penetrate, retard, simulate, tyro.
- (b) Make sentences with any ten of the following words: (10)
- Astound, castigate, crave, eloquence, gauche, impromptu, jeopardy, meddle, outrageous, placate, scrape, wither.
8. Write a précis of the following passage with a suitable title: (20)
- Authority in twentieth century is nowhere what it was. In certain spheres it has disappeared altogether. Public opinion no longer feels bound to enforce morality as it did by means of spoken disapproval and informal penalties. Fathers have ceased to rule the family, employers no longer enjoy the status of masters; The upper class have ceased to inspire imitation as models of correct behavior; school masters and university does no longer dominates the minds of the young. Things once considered inherently wrong are tolerated where they are thought to do no manifest harm.

HUM 111(WRE)

Contd ... Q. No. 5

Adolescents, who were once subject to the edicts of parental jurisdiction, live as they please, often earning as much as their fathers, and more legal rights at eighteen than their grandmothers possessed at any time during their lives. But this decline in authority has not necessarily meant a rise in liberty. For the concept of authority is not something which stands opposed to that of freedom, although some unreflective people think it does. Authority is really a special kind of power which rests on the consent and belief of those who live under it, without such free assent there can be no such thing as authority. So freedom in this important sense is part of the very notion of authority. And when authority is removed, it is only too likely that it will be followed either by the rule of naked power or by anarchy.

SECTION – A

There are **FOUR** questions in this Section. Answer any **THREE**.

1. (a) The forces F_1 , F_2 , and W on the block as shown in Fig. 1 are coplanar. It is desirable that the resultant R fall within the middle third of the base dimension b , the limiting position being at D which is $1/3$ of CE , show that $F_2 = \frac{b(F_1 + W)}{6nh}$. (15)
- (b) A steam engine is outlined in Fig. 2. The thrust on the crankshaft is 80 Kip when the steam is turned on and when $\theta = 15^\circ$. Find the vertical force N on the crosshead. Consider the engine is not moving. (16 $\frac{2}{3}$)
- (c) A load $Q = 4000$ N is acting at B on the cantilever structure as shown in Fig. 3. If the loads at A is $F = 10,000$ N, determine the resultant of the two forces and the distance from C to the line of action of the resultant measured along a line perpendicular to the resultant. (15)
2. (a) The Fig. 4 shows a three-hinged arch. Find the support reactions at A , B and C . (10)
- (b) A wedge B is inserted between a fixed surface A and a movable block C which weighs $W_c = 5000$ N as shown in the Fig. 5. For all slipping surfaces, let $f = 1/3$. If there is a horizontal resistance acting on C of $R = 8000$ N, what force Q will impose impending motion of C ? (20)
- (c) What do you understand by Catenary? Derive the equation for maximum tension which the engineer needs to know in design. (16 $\frac{2}{3}$)
3. (a) At the point of support of a cable (catenary), the tension is 25% greater than tension at the low point. The cable weighs 1 N per meter and the sag is 20 m. If the points of supports are on the same level, find the span. What is the length of the cable? (16 $\frac{2}{3}$)
- (b) Derive the equation which gives the relation between the tight tension and slack tension for belt friction. (15)
- (c) Two fixed cylinder as shown in the Fig. 6, have radii $r_A = 1$ ft and $r_B = 2$ ft, and $\theta = 30^\circ$. The load W is increased until $W = 130$ lb, when it is on the verge of moving downward, find frictional coefficient, f . (15)

WRE 101

4. (a) A table whose top is triangular in shape as shown in Fig. 7 has a vertical load of $W = 100$ lb. What is the force on each leg at A, B and C? (15)
- (b) Two cables A and B terminate on a pole as shown in the Fig. 8 and exert forces in the horizontal plane at C. The guy cable CD makes an angle with the pole of 45° and the anchor at D is to be so located that the pole will have only a compressive load (that is, $\sum F_x = 0$ and $\sum F_y = 0$). Let $\theta = 30^\circ$, $A = 5000$ N, $B = 8000$ N and $CE = 25$ m. Find the value of angle α and the tension in the cable CD. (16 $\frac{2}{3}$)
- (c) Three timbers AB, BC and BD, each 20 ft. long form a tripod as shown in Fig. 9. The ends of the timbers on the ground form an equilateral triangle ACD, the sides of which are each 20 ft. long. If the safe compressive load for each timber is 20,000 lb., What safe loads W may be suspended from point B? (15)

SECTION – B

There are **FOUR** questions in this Section. Answer any **THREE** questions.

5. (a) Determine the location of the centroid of the area enclosed by the curves $y^2 = 16x$ and $y = x$, shown in Fig. 10. (18)
- (b) A stone is thrown downward from a 100 ft tower with an initial velocity of 20 fps. Determine (18)
- (i) With what speed did it hit the ground?
- (ii) What is the velocity when $t = 2$ sec?
- (iii) What was the time of flight?
- (iv) What initial speed would reduce the time of flight to 50% of what found in part (iii)?
- (c) Derive the expression for tangential and normal acceleration of a point moving in a curved path. (10 $\frac{2}{3}$)
6. (a) Find the minimum radius of gyration of the T-section shown in Fig. 11. (24)
- (b) A particle whose acceleration $a = 3t - 12$ fps² is moving at a certain instant in a straight line with an initial velocity of 15 fps in the same direction as the initial acceleration. At time $t = 3$ sec, what are the velocity and displacement of the particle? (12 $\frac{2}{3}$)
- (c) For the composite body as shown in the Fig. 12, find the radius of gyration about the geometric axis. Unit weight of the material of the composite body is 490 lb/ft³. (10)
7. (a) In Fig. 13, $W_A = 200$ lb and $W_B = 100$ lb, $f_A = \frac{1}{4}$, $f_B = \frac{1}{3}$. Determine (16)
- (i) how far and in what direction does A travel from rest during 30 sec?
- (ii) What is the tension in the cable C and D?

WRE 101

- (b) A 4 ft cylinder, which weight 322 lb, rolls down a 15° incline from rest. What is its speed after it has rolled 50 ft? **(12 $\frac{2}{3}$)**
- (c) For the shaded area shown in Figure 14, determine (i) I_x (ii) I_y (iii) I_y' . **(18)**
8. (a) A jet of water, flowing at a rate of $W = 5$ lb per sec, issues from a nozzle with velocity $V_{sl} = 400$ fps (Fig. 15). It enters a fixed blade and is turned through 120° before it is discharged. Determine **(18)**
- (i) What are the horizontal and vertical components of the force exerted upon the fixed blade?
 - (ii) When the blade starts to move with a speed $V_b = 200$ fps toward the right, find the reactions Q_x and Q_y .
- (b) In Fig. 16, the 4 ft solid cylinder P weighs 966 lb and $\theta = 30^\circ$. The weight of Q is 193.2 lb and the pulley C has negligible weight and friction. If the system starts from the rest, determine. **(18)**
- (i) The velocity of P after 10 sec.
 - (ii) The tension in the cord
 - (iii) The frictional force between P and the incline
- (c) In Fig. 17, let $W_A = 1000$ lb and the speed of A changes from 60 fps to 10 fps during 25 sec. Determine **(10 $\frac{2}{3}$)**
- (i) The weight W
 - (ii) The distance moved by W during 25 sec.
 - (iii) The tension in the cable.
-

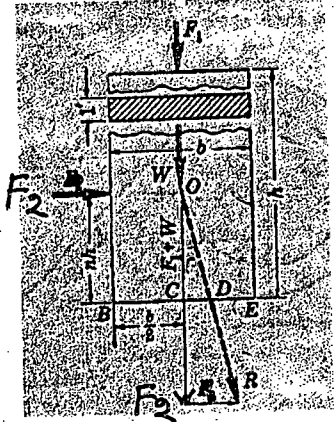

Figure-1 for Q-1 (a)

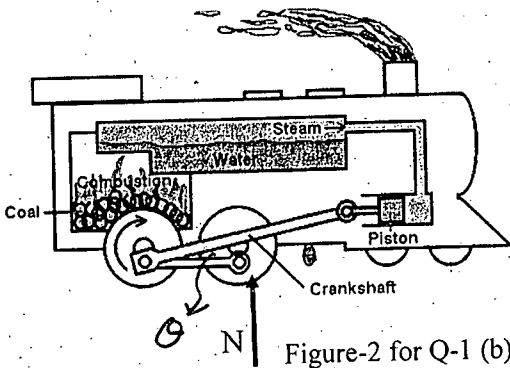

Figure-2 for Q-1 (b)

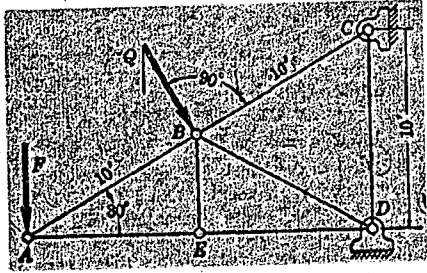

Figure-3 for Q-1 (c)

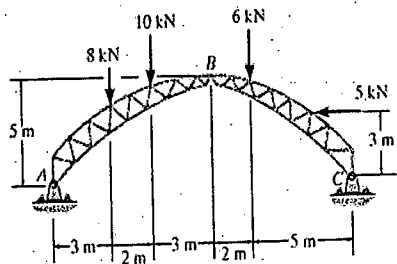

Figure-4 for Q-2 (a)

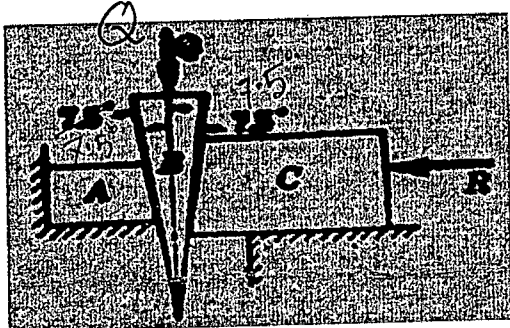

Figure-5 for Q-2 (b)

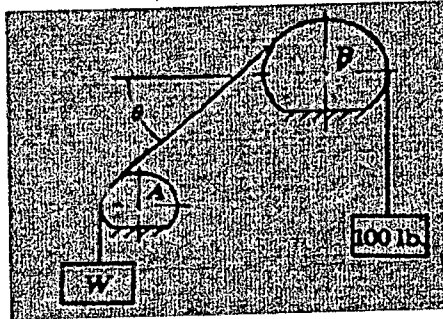

Figure-6 for Q-3 (c)

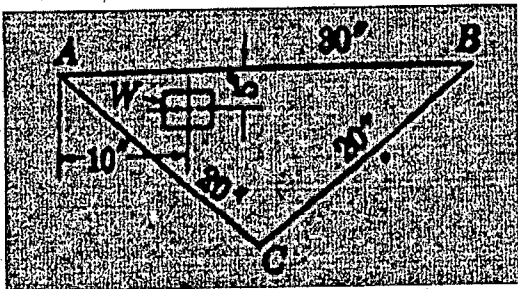

Figure-7 for Q-4 (a)

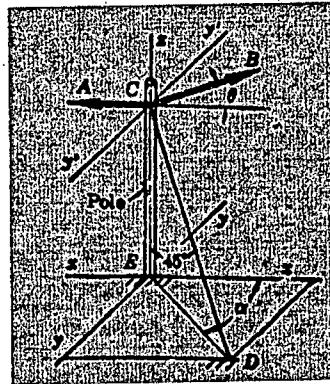

Figure-8 for Q-4(b)

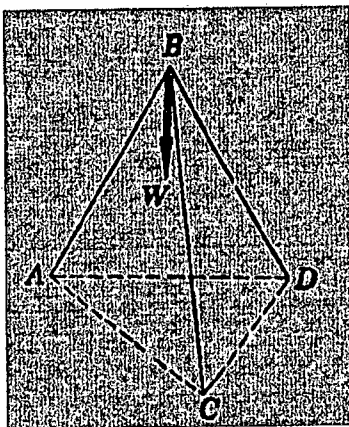

Figure-9 for Q-4 (c)

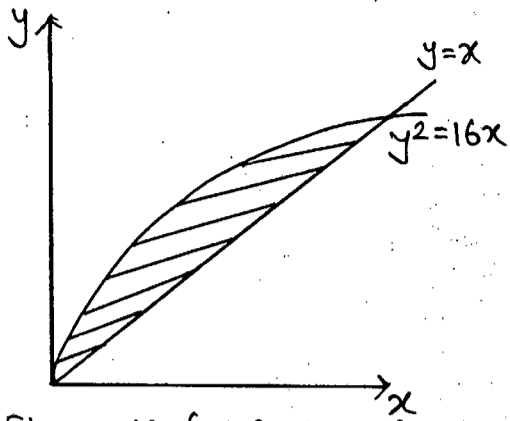

Figure 10 for Q.No 5(a)

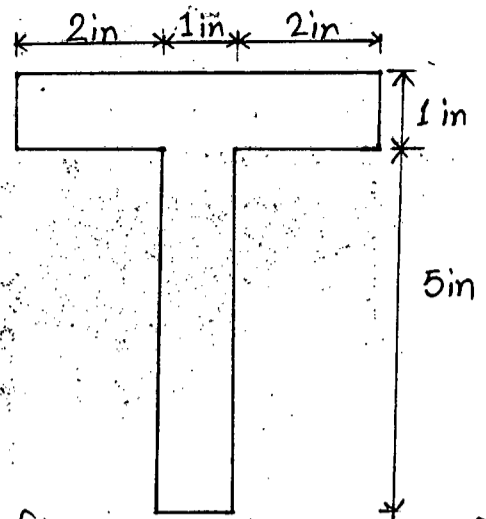

Figure 11 for Q.No. 6(a)

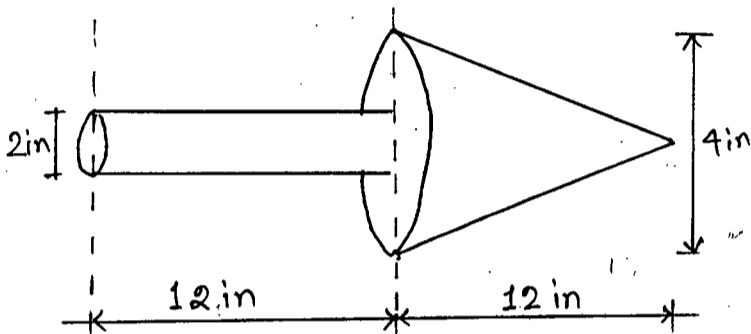

Figure 12 for Q.No 6(c)

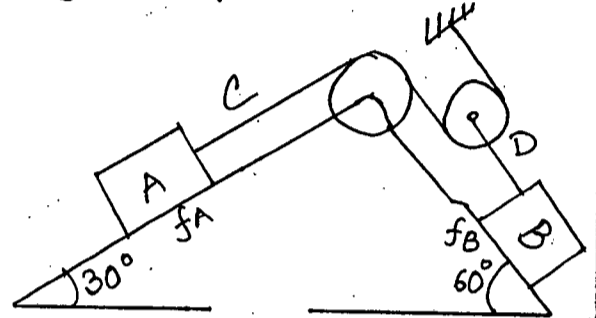

Figure 13 for Q.No. 7(a)

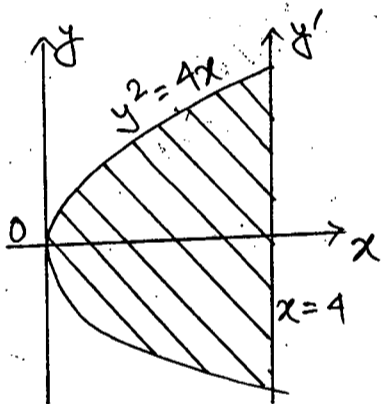

Figure 14 for Q.No 7(c)

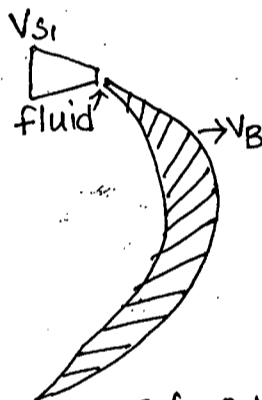

Figure 15 for Q.No-8(a)

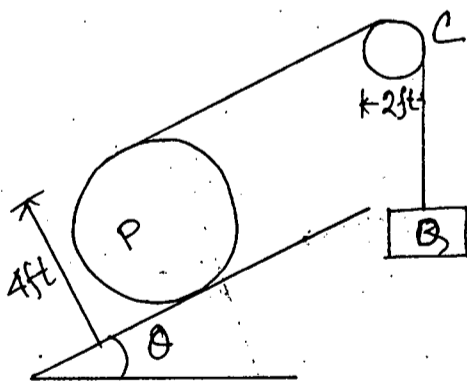

Figure 16 for Q.No 8(b)

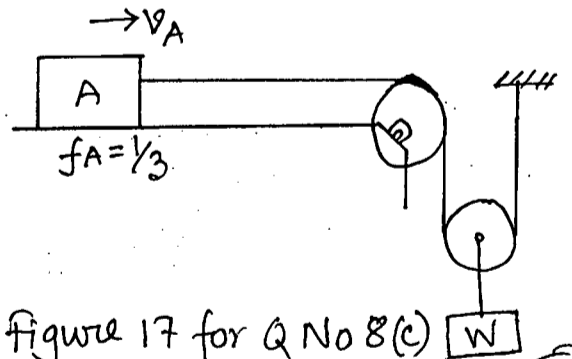

Figure 17 for Q No 8(c)

BANGLADESH UNIVERSITY OF ENGINEERING AND TECHNOLOGY, DHAKA

L-1/T-1 B. Sc. Engineering Examinations 2016-2017

Sub : **PHY 107** (Physical Optics, Waves and Oscillation, Heat and Thermodynamics)

Full Marks : 210

Time : 3 Hours

The figures in the margin indicate full marks.

USE SEPARATE SCRIPTS FOR EACH SECTION

SECTION – A

There are **FOUR** questions in this Section. Answer any **THREE**.

1. (a) What do you mean by oscillation. Briefly describe the impact of oscillation in our day-to-day life. (8)
- (b) For spring-mass system it is assumed that the spring has a point mass and is neglected during the time-period calculation. But in actual practice the spring had a finite mass and it affects the motion of the spring-mass system. Derive an expression for the time period of oscillation of the spring-mass system for a spring having non-zero finite mass. Hence explain the term effective mass of the spring. (17)
- (c) A spring stores potential energy U_0 when it is compressed a distance X_0 from its uncompressed length. In terms of U_0 how much energy does it store when it is compressed (i) twice as much and (ii) half as much? (10)

2. (a) What do you mean by damped harmonic motion. Write a general expression for the displacement of a particle executing damped oscillation and hence describe how the energy of a damped oscillation decays with time. (12)
- (b) Define the term damping coefficient “ γ ” and briefly explain how the γ of a damped oscillatory system can be measured. (8)
- (c) (i) When the note “middle C” on the piano is struck, its energy of oscillation decreases to one half its initial value in about 1 second. The frequency of middle C is 256 Hz. What is the quality factor (Q) of the system?
(ii) If the note of an octave higher (512 Hz) takes about the same time for its energy to decay, what is its Q? (15)

3. (a) What is forced oscillation. Set up the differential equation of motion for an object subjected to forced oscillation. (10)
- (b) Define steady state. Derive an expression for the displacement of a particle executing forced oscillation for steady state condition. (18)
- (c) A forced damped oscillator of mass m has a displacement varying with time given by $x = A \sin \omega t$. The resistive force is $-bv$ (where b is the damping constant and v is the velocity of the oscillator). From this information calculate how much work is done against the resistive force during one cycle of oscillation. (7)

PHY 107(WRE)

4. (a) Explain the term 'plane of vibration' and 'plane of polarization'. Write a short note on the quarter-wave plate. (12)
- (b) What is a Nicol prism? How it can be used as a polarizer? (15)
- (c) A beam of linearly polarized light is changed into circularly polarized light by passing it through a slice of 0.003 cm thick crystal. Calculate the difference in refractive indices of the two rays in the crystal assuming this to be of minimum thickness that will produce the effect. The wavelength of light is 6×10^{-5} cm. (8)

SECTION – B

There are **FOUR** questions in this Section. Answer any **THREE**.

5. (a) What are the essential conditions for observing interference of light? Why two independent sources of light of the same wavelength cannot produce interference fringes? (8)
- (b) Explain Newton's rings method for determining the wavelength of monochromatic light. (20)
- (c) Newton's rings are formed with reflected light of wavelength 5890 Å with liquid between the lens and the glass plate. The diameter of the 5th dark ring is 0.32 cm and radius of curvature of curved surface of the lens is 1.20 m. Calculate the refractive index of the liquid. (7)
6. (a) Define resolving power of an optical instrument. What do you mean by Rayleigh's criterion of resolution? Discuss the usefulness of the Rayleigh criterion for the resolving power of optical instruments. (10)
- (b) Discuss Fraunhofer diffraction of light at a circular aperture. (15)
- (c) In a Fraunhofer diffraction pattern due to a circular aperture, the screen is at a distance of 1.2 m from the convex lens. The diameter of the aperture is 0.2×10^{-3} m and the wavelength of light used is 589.3 nm. Calculate the separation between the central disc and the first minimum. (10)
7. (a) Define degrees of freedom. Determine the value of γ (ratio of specific heats) on the basis of degrees of freedom for mono-atomic gas and di-atomic gas. (9)
- (b) Derive Vander Waals equation of state for real gas with pressure and volume correction. (18)
- (c) Calculate the RMS velocity of the oxygen ($\rho = 1.43$ gm/liter) at 27°C. (8)

PHY 107(WRE)

8. (a) Define thermodynamic system and thermodynamic process. Classify and explain them. (8)
- (b) Describe a Carnot cycle. Calculate the work done in each operation of the Carnot cycle when the working substance is a perfect gas. (19)
- (c) The specific volume of steam at 100°C and 76 cm of mercury pressure is 1671 cm³/gm, and the latent heat of vaporization of water is 540 cal/gm. Calculate the change in boiling point of water due to change in pressure of 1 cm of mercury. (8)
-

BANGLADESH UNIVERSITY OF ENGINEERING AND TECHNOLOGY, DHAKA

L-1/T-1 B. Sc. Engineering Examinations 2016-2017

Sub : **MATH 131** (Differential and Integral Calculus)

Full Marks : 210

Time : 3 Hours

USE SEPARATE SCRIPTS FOR EACH SECTION

The figures in the margin indicate full marks.

Symbols used have their usual meaning.

SECTION - AThere are **FOUR** questions in this Section. Answer any **THREE**.

1. (a) A function
- $f(x)$
- is defined as follows:

$$f(x) = \begin{cases} -x, & \text{when } -2 \leq x \leq 0 \\ x, & \text{when } 0 < x < 1 \\ 3-x, & \text{when } 1 \leq x \leq 2 \end{cases}$$

(17)

Discuss the continuity and differentiability of $f(x)$ at $x = 0$ and $x = 1$.

(b) Evaluate: $\lim_{x \rightarrow 0} \left(\frac{a^x + b^x}{2} \right)^{1/x}$

(10)

(c) Evaluate: $\lim_{x \rightarrow 0} \left[\frac{1}{x^2} - \frac{1}{\sin^2 x} \right]$

(8)

2. (a) If
- $x = \sin\left(\frac{\ln y}{m}\right)$
- , show that
- $(1-x^2)y_{n+2} - (2n+1)xy_{n+1} - (n^2+m^2)y_n = 0$
- and find the

value of y_n , when $x = 0$.

(17)

- (b) Expand the function
- $\cos x$
- in powers of
- x
- with remainders
- R_n
- in Schlomolich and Roche's, Lagranges and Cauchy's form.

(18)

3. (a) State Euler's theorem on homogeneous function and show that

$$(x^2 + y^2 + z^2) \left(\frac{\partial^2 u}{\partial x^2} + \frac{\partial^2 u}{\partial y^2} + \frac{\partial^2 u}{\partial z^2} \right) = 1 \quad \text{if } u = \ln \sqrt{x^2 + y^2 + z^2}$$

(17)

- (b) Determine the maximum and minimum values of
- $y = x + \sin 2x$
- for
- $0 < x < 2\pi$
- .

(12)

- (c) Verify the Mean Value Theorem for the function
- $f(x) = x - x^3$
- in the interval
- $(-2, 1)$
- .

(6)

4. (a) Find the radius of curvature of the curve
- $\sqrt{x} + \sqrt{y} = \sqrt{a}$
- at the point where
- $y = x$
- cuts it.

(12)

- (b) Find the angle of intersection of two curves
- $r = a \sin 2\theta$
- and
- $r = a \cos 2\theta$
- .

(12)

- (c) Find the pedal equation of the curves
- $x^{2/3} + y^{2/3} = a^{2/3}$
- .

(11)

Contd P/2

MATH 131(WRE)**SECTION – B**

There are **FOUR** questions in this Section. Answer any **THREE**.

5. Evaluate the following integrals:

$$(i) \int \frac{x^3 + x^2 + x + 1}{\sqrt{x^2 + 2x + 3}} dx \quad (13)$$

$$(ii) \int \frac{1}{\sin x(2 + \cos x - 2 \sin x)} dx \quad (12)$$

$$(iii) \int \frac{\sin^{-1} x}{(1 - x^2)^{\frac{3}{2}}} dx \quad (10)$$

6. (a) Derive the reduction formula of $\int x^m (\log x)^n dx$ and hence evaluate $\int x^3 (\log x)^2 dx$. (13)

(b) Find the value of $\int_0^{\pi} \frac{x \tan x}{\sec x + \cos x} dx$. (10)

(c) Evaluate: $\int_0^{\infty} \frac{\log\left(x + \frac{1}{x}\right)}{1 + x^2} dx$. (12)

7. (a) Derive the relation between Beta and Gamma function. Hence find the value of

$$\int_0^1 \frac{x^2 dx}{\sqrt{1-x^4}} \times \int_0^1 \frac{dx}{\sqrt{1+x^4}} \quad (20)$$

(b) For what values of p does the integral $\int_1^{+\infty} \frac{dx}{x^p}$ converge? (8)

(c) Find the value of the improper integral $\int_{-\infty}^{\infty} \frac{x}{(x^2 + 3)^2} dx$. (7)

8. (a) Find the entire area within the cardioid of $r = 1 - \cos \theta$. (11)

(b) Find the volume of the solid formed by the revolution of a loop of the curve $(x - 4a)y^2 = ax(x - 3a)$ about the x -axis. (13)

(c) Evaluate the triple integral $\int_{-1.0}^2 \int_0^3 \int_0^2 72xy^2z^3 dz dy dx$. (11)