

SECTION – A

There are **FIVE** questions in this section. Answer any **FOUR**.

1. (a) As shown in Fig.-1, a rigid beam with negligible weight is pinned at one end and attached to two vertical rods. The beam was initially horizontal before the load $W = 35$ kips was applied. Find the vertical movement of W . (16¼)
 (b) To support a load $P = 250$ kN determine the necessary diameter for rods AB and AC for the tripod shown in Fig-2. Neglect the weight of the structure and assume that the joints are pin connected. No allowance has to be made for threads. The allowable stress in tension is 120 MPa. All dimensions are in meters. (10)
2. Draw shear force and bending moment diagrams for the beam with load shown in Fig-3. (26¼)
3. Draw shear force and bending moment diagrams for the beam with load shown in Fig-4. (26¼)
4. A box beam is composed of four planks, each 2 inch by 8 inch, securely spiked together to form the section shown in Fig-5. If $W_0 = 300$ lb/ft, find P to cause a maximum flexural stress of 1400 psi. (26¼)
5. A small steel T beam is used in an inverted position to span 400 mm. If, due to the application of the three forces shown in Fig-6, the longitudinal gage at A registers a compressive strain of 50×10^{-5} , how large are the applied forces? $E = 200$ GPa. (26¼)

SECTION-B

There are **FOUR** questions in this section. Answer any **THREE**.

6. (a) The two bars are made of polystyrene, which has the stress-strain diagram shown in Fig. 7. Determine the cross-sectional area of each bar so that the bars rupture simultaneously when the load $P = 3$ kip. Assume that buckling does not occur. The two bar system is also shown in Fig. 7(a). (17)

CE 221

Contd... Q. No. 6(a)

- (b) The elastic portion of the tension stress-strain diagram for an aluminum alloy is shown in Fig. 8. The specimen used for the test has a gauge length of 2 in and a diameter of 0.5 in when the applied load is 9 kip, the new diameter of the specimen is 0.49935 in. Compute the shear modulus G_{al} for the aluminum. (18)
7. (a) The rod has a diameter of 0.5 in and a weight of 5 lb/ft. Determine the maximum torsional stress in the rod at a section located at A due to the rod's weight. The rod system is shown in Fig. 9. (15)
- (b) The device (Fig. 10) serves as a compact torsional spring. It is made of A-36 steel and consists of a solid inner shaft CB which is surrounded by and attached to a tube AB using a rigid ring at B. The ring at A can also be assumed rigid and is fixed from rotating. If a torque of $T = 2$ kip.in is applied to the shaft, determine the angle of twist at the end C and the maximum shear stress in the tube and shaft. Given $G = 11000$ psi. (20)
8. (a) A beam (as shown in Fig. 11) is constructed from five boards bolted together. Determine the maximum shear force developed in each bolt if the bolts are spaced $S = 250$ mm apart and the applied shear is $V = 35$ kN. (18)
- (b) The barrel is filled to the top with water. Determine the distance S that the top hoop should be placed from the bottom hoop so that the tensile force in each hoop is the same. Also, what is the force in each hoop? The barrel has an inner diameter of 4 ft. Neglect its wall thickness. Assume that only the hoops resist the water pressure. Note: water develops pressure in the barrel according to Pascal's law $P = 62.4Z$ lb/ft², where Z is the depth from the surface of water in feet. Use Fig. 12 for the problem. (17)
9. (a) The tank of the air compressor (Fig. 13) is subjected to an internal pressure of 90 psi. If the internal diameter of the tank is 22 in and the wall thickness is 0.25 in., determine the stress components acting at point A. Draw a volume element of the material at this point and show the results on the element. (18)
- (b) Determine the location e of the shear center, point o, for the thin-walled member having the cross section in Fig. 14. The member segments have the same thickness t . (17)
-

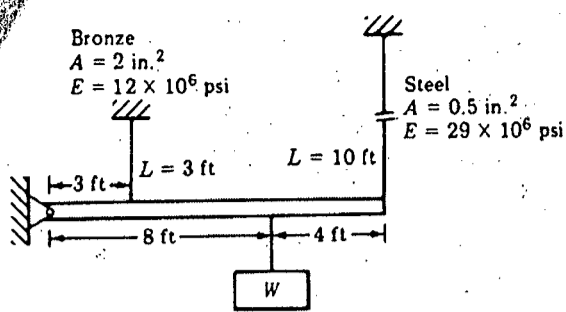

Figure-1

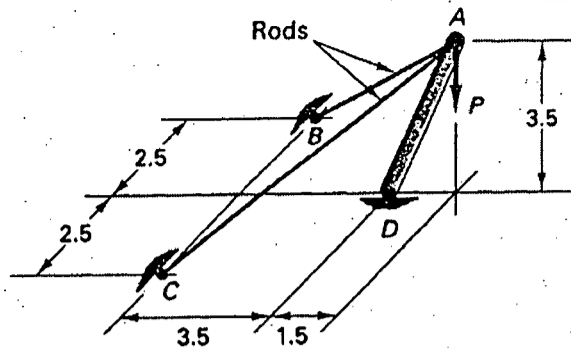

Figure-2

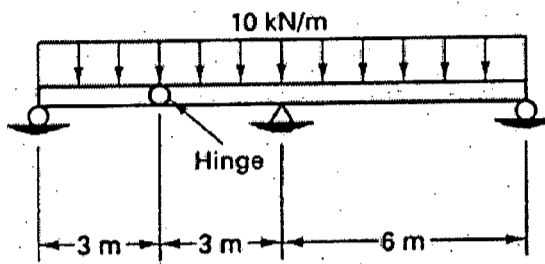

Figure-3

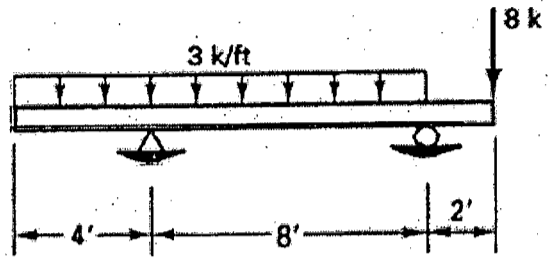

Figure-4

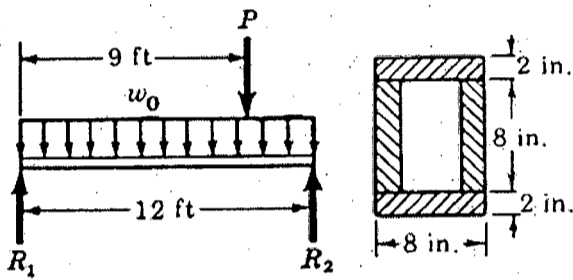
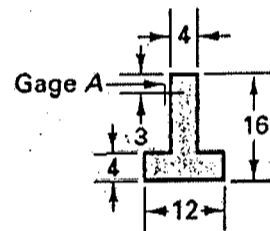
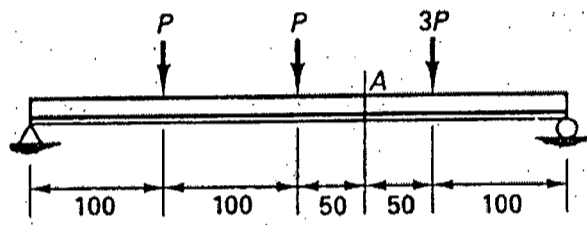

Figure-5



Beam section
Figure-6

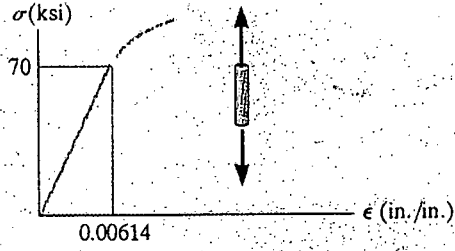
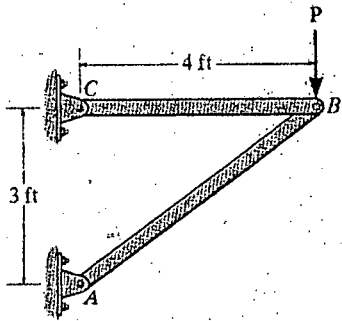

Fig. 7(b) 8

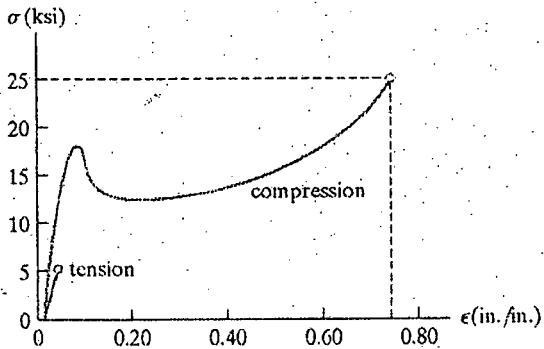

Fig. 7(a) 8

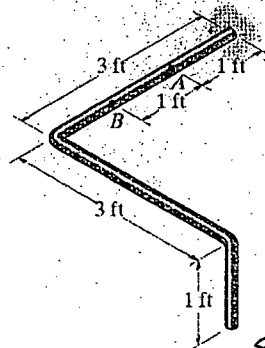

Fig. 7(b) 9

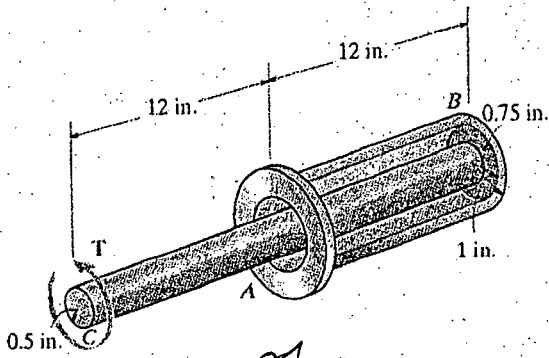

Fig. 7(b) 10

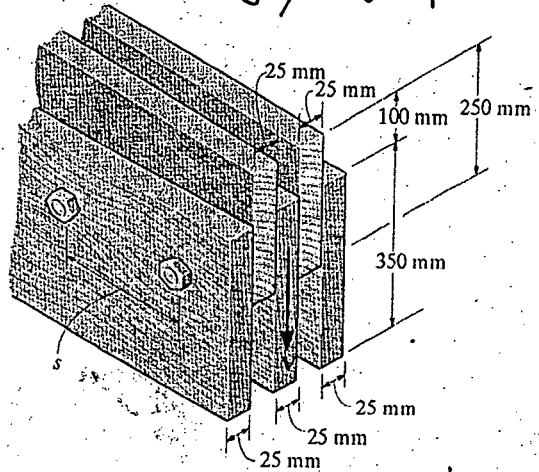

Fig. 8(a) 11

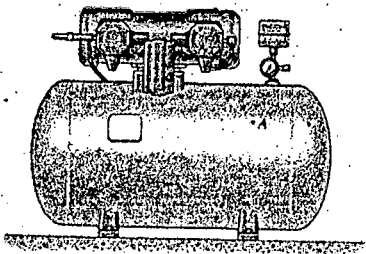

Fig. 4(b) 13

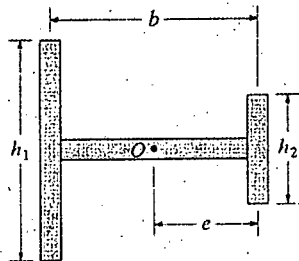

Fig. 4(b) 14

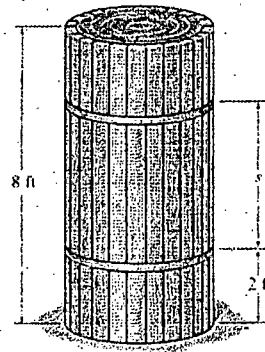

Fig. 8(b) 12

SECTION – A

There are **FOUR** questions in this section. Answer any **THREE**.

1. (a) What do you understand by geomorphology? Briefly explain various types of geomorphic processes. (15)
- (b) Define cycle of erosion and write down the characteristics of various stages of streams. (10)
- (c) What do you understand by glacial deposits? Briefly explain the land forms produced by glacial deposits. (10)
2. (a) Sketch and define parameters of meandering river. Explain different theories of meandering. (15)
- (b) A meandering river has a radius of 150 m, calculate the amplitude of the river according to Leopold and Wolman. (8)
- (c) Define Lacustrine deposit. Classify and explain various types of lacustrine deposits. (12)
3. (a) What do you understand by drainage pattern? Briefly explain various types of drainage pattern with neat sketches. (15)
- (b) What is stream order? Write down the purpose of making stream order and explain Horton's system of stream ranking. (12)
- (c) A stream network is shown in Figure-1, make the stream order according to Horton's method of stream order. (8)
4. (a) Define and classify Aeolian deposits. (5)
- (b) For the stream network shown in Figure-1, calculate (i) Bifurcation ratio (ii) Drainage density and (iii) Stream frequency. Given that the length of 1st, 2nd, 3rd and 4th order streams are 5 miles, 15 miles, 125 miles and 200 miles respectively. (15)
- (c) What do you understand by fluvial deposits? Classify fluvial deposits according to Fisk (1947), Happ, Rittenhouse and Dobson (1940) and Allen (1965). (10)
- (d) Define (i) Channel bar, (ii) point bar, (iii) Delta bar (iv) neck cutoff and (v) natural levee. (5)

WRE 203

SECTION-B

There are **FOUR** questions in this section. Answer any **THREE**.

5. (a) What is rock cycle? Briefly describe the rock cycle and the mechanism of rock formation. (15)
- (b) Write short notes on (20)
- (i) Olivine
 - (ii) Augite
 - (iii) Quartz
 - (iv) Feldspar.
6. (a) What are the causes of igneous activity? Briefly describe the texture of igneous rock. (10)
- (b) What is metamorphism? Describe the agents of metamorphism. (10)
- (c) Describe the features of sedimentary rocks. (15)
7. (a) What is lithification? Briefly describe the mechanism of lithification. (15)
- (b) Differentiate between (20)
- (i) Convergent Boundary and Divergent Boundary
 - (ii) Folds and Flow
 - (iii) Joint and Fault
 - (iv) Epicenter and Hypocenter.
8. (a) Describe the types of surface waves from seismicity with figure. (10)
- (b) Differentiate between P-waves and S-waves. (10)
- (c) Write down the geological characteristics of Bangladesh. Also describe why Bangladesh is susceptible to earthquake. (10)
- (c) What are the major plates around the world? (5)
-

= 3 =

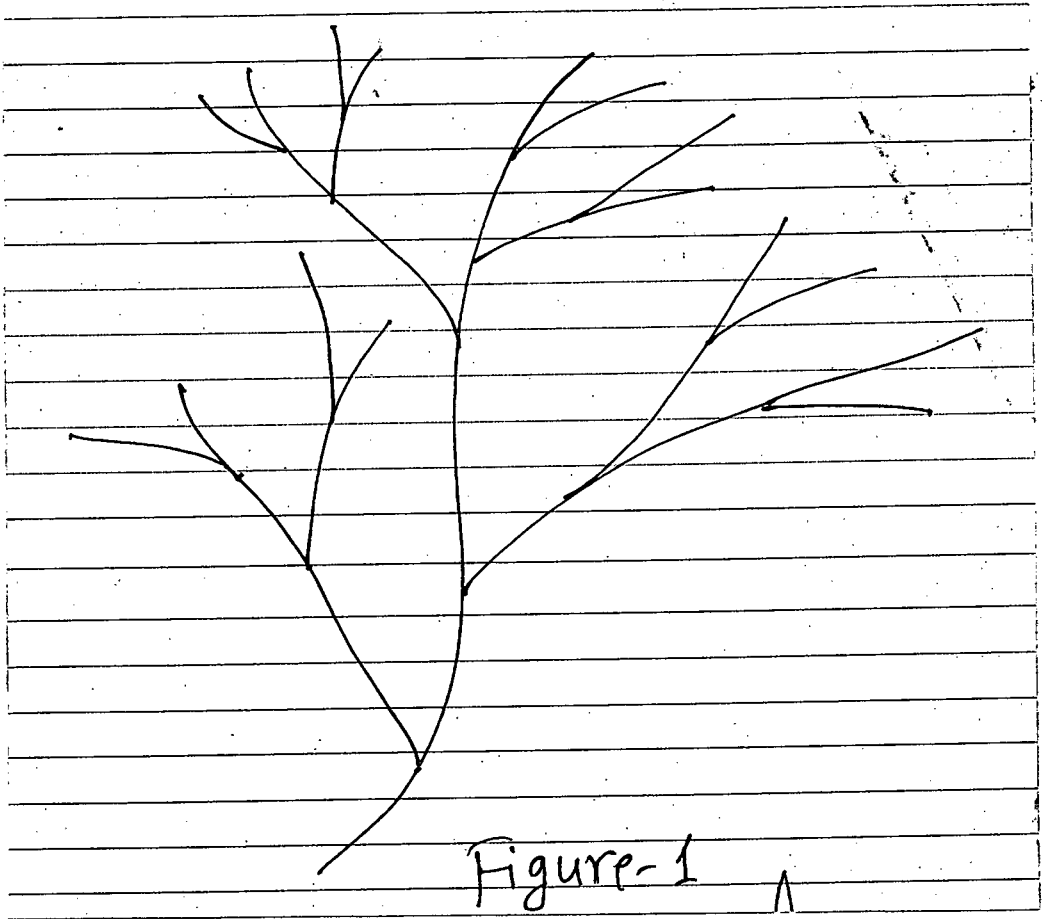

Figure-1

SECTION – AThere are **FOUR** questions in this section. Answer any **THREE**.

1. (a) Describe the arrangements and operational procedure of a Hoffman's kiln with neat sketch. (20)
- (b) Write down the importance of studying engineering materials. Which factors should be considered while selecting various materials for construction? (5+5=10)
- (c) Write down the role of the followings in brick: (5)
- (i) Alumina;
- (ii) Lime.
2. (a) Describe the influence of aluminates to sulfate ratio in the hydration of portland cement with neat sketches. (20)
- (b) Write short notes on the following sound insulating materials: (5+5=10)
- (i) Acoustical plaster;
- (ii) Uni-fill acoustical plaster.
- (c) How the following special properties of cement can be achieved: (5)
- (i) Rapid hardening cement;
- (ii) Quick setting cement.
3. (a) The sieve analysis data of two types of aggregate is given below. (20)

Sieve No.	% passing	
	Aggregate-1	Aggregate-2
No. 4	100	100
No. 8	85	70
No. 16	55	58
No. 30	45	32
No. 50	15	19
No. 100	8	10
No. 200	2	5

- (i) Calculate the ratio of each type of aggregate to be mixed to obtain the following gradation curve.
- (ii) From the following gradation curve, calculate the fineness modulus of that aggregate sample.

CE 291/WRE

Contd... Q. No. 3

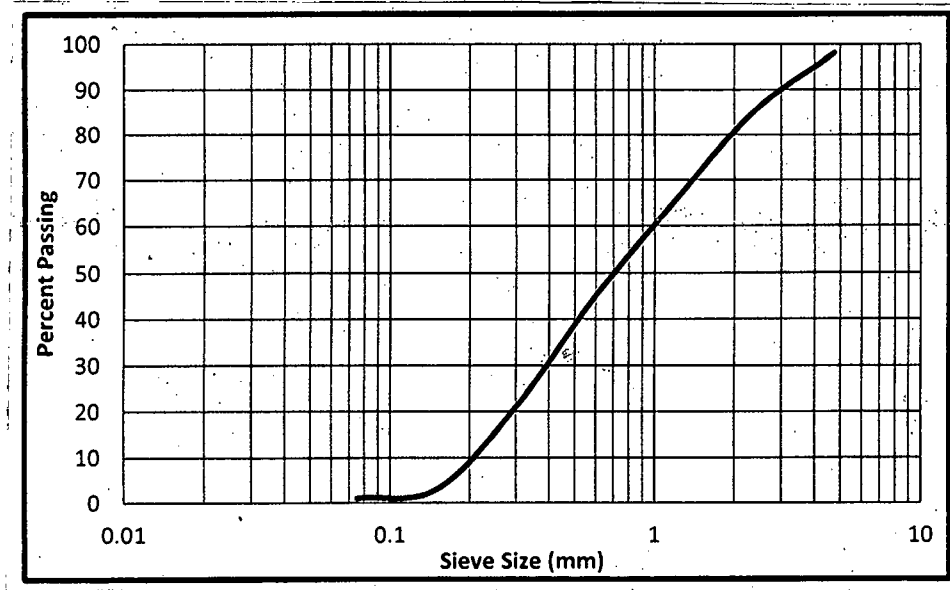

(b) Write short notes on any five types of special glasses. (10)

(c) Classify the aggregates based on the following properties: (5)

- (i) Size
- (ii) Shape

Give examples whenever possible.

4. (a) Briefly describe the effects of water-cement ratio and porosity on the strength development of fresh and hardened concrete with appropriate diagrams. (20)

(b) The following masses are used to produce a batch of concrete. (10)

Calculate:

- (i) Weight of fine and course aggregate in SSD condition;
- (ii) Water content and cementitious material ratio;
- (iii) Aggregate and cementitious material ratio.

Material	Batch Mass (kg)
Cement	400
Fly Ash	70
Dry sand (2% moisture deficit from SSD condition)	950
Wet gravel (absorption capacity 2%, total moisture 5%)	1250
Water (added during batch mixing)	150

[Hint: Total moisture = Moisture at SSD condition + Excess surface moisture]

(c) Briefly describe the stages of varnishing process. (5)

CE 291/WRE

SECTION – B

There are **FOUR** questions in this section. Answer any **THREE**.

5. (a) Write short notes on: (5×4=20)
- (i) Bulking of sands;
 - (ii) Seasoning of timber;
 - (iii) Vulcanization of rubber;
 - (iv) Efflorescence of bricks.
- (b) What are the main compositions of paints? Write down the main functions of each element. (10)
- (c) What is slaked lime? Why slaked lime should not be kept in damp places? (5)
6. (a) Mix proportions (SSD basis, lb/yd³) of concrete needs to be adjusted for the given job specification. Determine the mix proportions for the trial batch of 0.10 yd³ concrete after moisture correction. (20)

Given:

Job Specification	
Types of Construction	RC Foundation
Exposure	Severe
Specified 28 days compressive strength	4500 psi
Maximum size of aggregate	1.5 inch

Characteristics of materials selected	Cement, ASTM type I	Fine Aggregate	Coarse Aggregate
Bulk specific gravity	3.0	2.25	2.8
Bulk density (lb/ft ³)	200	160	170
Dry-rodded unit wt (lb/ft ³)	-	-	100
FM	-	2.75	-
Moisture deviation From SSD condition (%)	-	+1.5	-3.5

Design the mix as per ACI method using the above information and the data given in Annexure I to III.

- (b) What are the general considerations for concrete mix design? (10)
- (c) Briefly explain the significance of objectives of concrete mix design. (5)

CE 291/WRE

7. (a) For the loading history shown below, draw the likely strain response of: (20)

(i) Elastic; (ii) Plastic; (iii) Elasto-Plastic and (iv) Elasto-Visco-Plastic material.

Assume, equal time interval, i.e., $\Delta t = t_1 - t_0 = t_2 - t_1 = t_3 - t_2 = t_4 - t_3$.

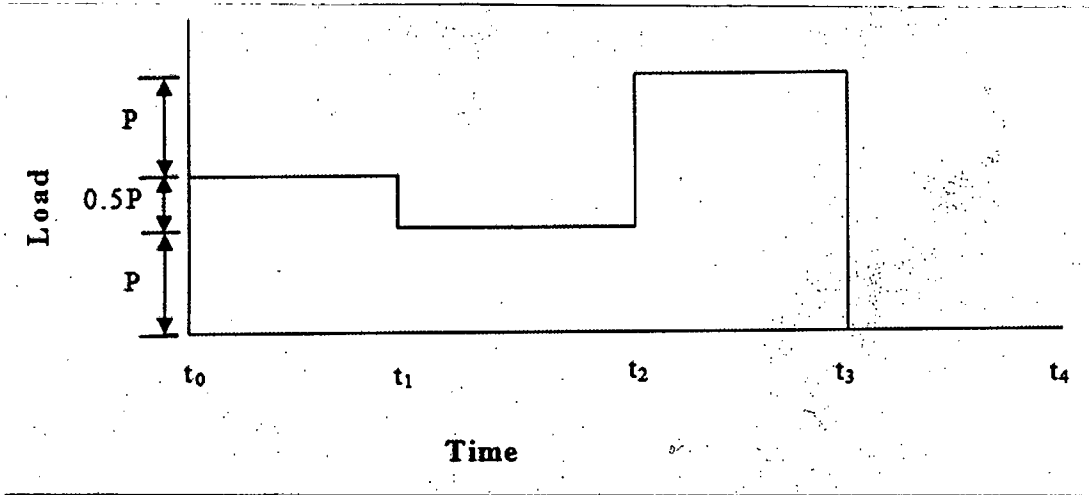

(b) Define FRP and briefly describe the use of FRP as a retrofitting material. (10)

(c) Write down the relative advantages and disadvantages of using ferrocement. (5)

8. (a) Differentiate between: (4×5=20)

- (i) Thermo plastics and Thermo setting plastic;
- (ii) Natural rubber and Synthetic rubber;
- (iii) Dry rot and Wet rot of timber;
- (vi) Veneer and Plywood.

(b) Briefly explain the factors that affect the workability of fresh concrete. (10)

(c) Write down the effects of following impurities in iron: (5)

- (i) Silicon;
 - (ii) Sulfur.
-

= 5 =

Annexure I

TABLE 9-2 Approximate Mixing Water and Air Content Requirements for Different Slumps and Nominal Maximum Sizes of Aggregates

Slump, in.	Water, lb/yd ³ of concrete for indicated nominal maximum sizes of aggregate							
	3/8 in.*	1/2 in.*	3/4 in.*	1 in.*	1 1/2 in.*	2 in.*†	3 in.†	6 in.†
Non-air-entrained concrete								
1 to 2	350	335	315	300	275	260	220	190
3 to 4	385	365	340	325	300	285	245	210
6 to 7	410	385	360	340	315	300	270	—
More than 7 [‡]	—	—	—	—	—	—	—	—
Approximate amount of entrapped air in non-air-entrained concrete, percent	3	2.5	2	1.5	1	0.5	0.3	0.2
Air-entrained concrete								
1 to 2	305	295	280	270	250	240	205	180
3 to 4	340	325	305	295	275	265	225	200
6 to 7	365	345	325	310	290	280	260	—
More than 7 [‡]	—	—	—	—	—	—	—	—
Recommended averages total air content, percent for level of exposure:								
Mild exposure	4.5	4.0	3.5	3.0	2.5	2.0	1.5 ^{§§}	1.0 ^{§§}
Moderate exposure	6.0	5.5	5.0	4.5	4.5	4.0	3.5 ^{§§}	3.0 ^{§§}
Severe exposure [§]	7.5	7.0	6.0	6.0	5.5	5.0	4.5 ^{§§}	4.0 ^{§§}

*The quantities of mixing water given for air-entrained concrete are based on typical total air content requirements as shown for "moderate exposure" in the table above.

†The slump values for concrete containing aggregate larger than 1 1/2 in. are based on the slump tests made after removal of particles larger than 1 1/2 in. by wet-screening.

‡For concrete containing large aggregates that will be wet-screened over the 1 1/2 in. sieve prior to testing for air content, the percentage of air expected in the 1 1/2 in. minus material should be as tabulated in the column. However, initial proportioning calculations should include the air content as a percent of the whole.

§When using large aggregate in low cement factor concrete, air entrainment need not be detrimental to strength. In most cases mixing water requirement is reduced sufficiently to improve the water-cement ratio and to thus compensate for the strength-reducing effect of air-entrained concrete. Generally, therefore, for these large nominal maximum sizes of aggregate, air contents recommended for extreme exposure should be considered even though there may be little or no exposure to moisture and freezing.

TABLE 9-1 Recommended Slump for Various Types of Construction

Types of construction	Slump (in.)	
	Maximum*	Minimum
Reinforced foundation walls and footings	3	1
Plain footings, caissons, and substructure walls	3	1
Beams and reinforced walls	4	1
Building columns	4	1
Pavements and slabs	3	1
Mass concrete	2	1

* May be increased by 1 in. for consolidation methods other than vibration.
SOURCE: Reproduced with permission from the American Concrete Institute.

Annexure II

TABLE 9-3 Relationships between Water-Cement Ratio and Compressive Strength of Concrete

Water-cement ratio, by weight		
Compressive strength at 28 days (psi) ^a	Non-air-entrained concrete	Air-entrained concrete
6000	0.41	—
5000	0.48	0.40
4000	0.57	0.48
3000	0.68	0.59
2000	0.82	0.74

^aValues are estimated average strengths for concrete containing not more than percentage of air shown in Table 9-2. For a constant water-cement ratio, the strength of concrete is reduced as the air content is increased. Strength is based on 6 by 12 in. cylinders moist-cured 28 days at 73.4 ± 3°F (23 ± 1.7°C) in accordance with Sec. 9(b) of ASTM C31, for *Making and Curing Concrete Compression and Flexure Test Specimens in the Field*.

SOURCE: Reproduced with permission from the American Concrete Institute.

TABLE 9-4 Recommendations for Normal Weight Concrete Subject to Sulfate Attack

Exposure	Water soluble sulfate ^a (SO ₄) in soil, percent	Sulfate ^a (SO ₄) in water, ppm	Cement	Water-cement ratio, maximum ^f
Mild	0.00-0.10	0-150	—	—
Moderate [†]	0.10-0.20	150-1500	Type II IP (MS), IP (MS) [‡]	0.50
Severe	0.20-2.00	1500-10,000	Type V [§]	0.45
Very severe	Over 2.00	Over 10,000	Type V + pozzol and or slag [¶]	0.45

^aSulfate expressed as SO₄ is related to sulfate expressed as SO₃ as in reports of chemical analysis of cement as SO₃ × 1.2 = SO₄.

[†]When chlorides or other de-passivating agents are present in addition to sulfate, a lower water-cement ratio may be necessary to reduce corrosion potential of embedded items. Refer to Chap. 5.

[‡]Or a blend of Type I cement and a ground granulated blast furnace slag or a pozzolan that has been determined by tests to give equivalent sulfate resistance.

[§]Or a blend of Type II cement and ground granulated blast furnace slag or a pozzolan that has been determined by tests to give equivalent sulfate resistance.

[¶]Use a pozzolan or slag that has been determined by tests to improve sulfate resistance when used in concrete containing Type V cement.

SOURCE: ACI Committee 201, Guide to Durable Concrete, *ACI Mat. J.*, Vol. 88, No. 5, p. 553, 1991.

Annexure III

TABLE 9-5 Volume of Coarse Aggregate Per Unit of Volume of Concrete

Maximum size of aggregate (in.)	Volume of dry-rodded coarse aggregate* per unit volume of concrete for different fineness moduli of sand			
	2.40	2.60	2.80	3.00
3/8	0.50	0.48	0.46	0.44
1/2	0.59	0.57	0.55	0.53
3/4	0.66	0.64	0.62	0.60
1	0.71	0.69	0.67	0.65
1 1/2	0.75	0.73	0.71	0.69
2	0.78	0.76	0.74	0.72
3	0.82	0.80	0.78	0.76
6	0.87	0.85	0.83	0.81

* Volumes are based on aggregates in dry-rodded condition as described in ASTM C29, *Unit Weight of Aggregate*. These volumes are selected from empirical relationships to produce concrete with a degree of workability suitable for usual reinforced construction. For less workable concrete such as required for concrete pavement construction they may be increased about 10 percent. For more workable concrete, such as may sometimes be required when placement is to be by pumping, they may be reduced up to 10 percent.

SOURCE: Reproduced with permission from the American Concrete Institute

TABLE 9-6 First Estimate of Weight of Fresh Concrete

Maximum size of aggregate (in.)	First estimate concrete weight* (lb/yd ³)	
	Non-air-entrained concrete	Air-entrained concrete
3/8	3840	3690
1/2	3890	3760
3/4	3960	3840
1	4010	3900
1 1/2	4070	3960
2	4120	4000
3	4160	4040
6	4230	4120

* Values calculated for concrete of medium richness (550 lb of cement per cubic yard) and medium slump with aggregate specific gravity of 2.7. Water requirements based on values for 3 to 4 in. of slump in Table 9-2. If desired, the estimated weight may be refined as follows when necessary information is available: for each 10-lb difference in mixing water from the Table 9-2 values for 3 to 4 in. of slump, correct the weight per cubic yard 15 lb in the opposite direction; for each 100-lb difference in cement content from 550 lb, correct the weight per cubic yard 15 lb in the same direction; for each 0.1 by which aggregate specific gravity deviates from 2.7, correct the concrete weight 100 lb in the same direction.

SOURCE: Reproduced with permission from the American Concrete Institute.

BANGLADESH UNIVERSITY OF ENGINEERING AND TECHNOLOGY, DHAKA

L-2/T-1 B. Sc. Engineering Examinations 2016-2017

Sub: **CE 381** (Principles of Soil Mechanics)

Full Marks: 280

Time: 3 Hours

USE SEPARATE SCRIPTS FOR EACH SECTION

The figures in the margin indicate full marks.

SECTION – AThere are **FOUR** questions in this section. Answer any **THREE**.

Assume any reasonable value of missing data.

1. (a) Basic differential equation of Terzaghi's 1-D consolidation of saturated clays is

$$\frac{\partial u}{\partial t} = C_v \frac{\partial^2 u}{\partial z^2}$$

(40)

- (i) What is C_v ; mention various methods of its determination using the laboratory data. Describe any one.
- (ii) Using a neat sketch mentioning the boundary conditions to solve the above differential equation, write down solution for the above equation. Define the various terms used in the equation.
- (iii) Use the solution to define the degree of consolidation (U_z) at a distance z at any time t . Provide graphical representation of typical variations of U_z with T_v and z/H_{dr} . State briefly how do you obtain this plot using the expression of U_z as defined above.
- (iv) Also define the average degree of consolidation (U) using U_z and write down its final form of expression. Using this final form, mention the steps to obtain the $U \sim T_v$ plot. Provide graphical representation of the typical variations of U and T_v . State the typical values of T_v when $U \leq 60\%$ and $U > 60\%$.

- (b) According to the results from a consolidation test, the preconsolidation stress (σ_c) for a certain soil sample is 850 psf. The in-situ vertical effective stress at the sample location is 797 psf, and the proposed load will cause σ_z to increase by 500 psf. Which equation should be used to compute the consolidation settlement? Why?

(6 $\frac{2}{3}$)

2. (a) State the factors affecting such shallow depth soil compaction techniques with emphasis on:

(16 $\frac{2}{3}$)

- (i) Soil type;
- (ii) Moisture content;
- (iii) Lift thickness and
- (iv) Number of roller passes.

CE 381/WRE

Contd... Q. No. 2

(b) A 3.0 ft cut is to be made across an entire 2.5-acre site. The average unit weight of this soil is 118 pcf, and the average moisture content is 9.6%. It has a Proctor maximum dry unit weight of 122 pcf and an optimum moisture content of 11.1%. The excavated soil will be placed on a nearby site and compacted to an average relative compaction of 93%. Compute the volume of fill that will be produced and express your answer in cubic yards. (15)

(c) Define dry unit weight at zero-air-void and using phase diagram, deduce:
 $(\gamma_{zav})_d = G_s \gamma_s / (1 + e) = G_s \gamma_w / (1 + w G_s)$ (15)

Write down the properties of Modified Proctor test. How do you use the information of laboratory compaction test result of a clay in the field in quality control scheme?

3. (a) Twelve undisturbed soil samples were obtained from borings in a proposed cut area. These samples had an average γ_d of 108 pcf and an average w of 9.1%. A proctor compaction test performed on a representative bulk sample produced $(\gamma_d)_{max} = 124$ pcf and $w_0 = 12.8\%$. A proposed grading plan calls for 12,000 yd³ of cut and 11,500 yd³ of fill, and the specifications call for a relative compaction of at least 90%. Compute: (16 2/3)

- (i) The shrinkage factor
- (ii) The required quantity of import or export based on the unit weight of the cut
- (iii) The weight of import or export in tons using the moisture content of the cut.

(b) A 1.20-m thick strata of sand has a void ratio of 1.81. A contractor passes a vibratory roller over the strata, which densifies it and reduces its void ratio to 1.23. Compute its new thickness. (15)

Using basic definition (don't use phase diagram), derive the following equation for a soil element:

$$S_r = \frac{\omega G_s}{e}$$

(c) A 10,000 ft³ mass of saturated clay had a void ratio of 0.962 and a specific gravity of soil solids of 2.71. A fill was then placed over the clay, causing it to compress. During this process, some of water was squeezed out of the voids. However, volume of solids remains unchanged. After the consolidation was complete, the void ratio had become 0.758. Compute: (15)

- (i) initial and final moisture content of water
- (ii) new volume of the clay, and
- (iii) volume of water squeezed out.

CE 381/WRE

4. (a) A 1.00 m^3 element of soil is located below the groundwater table. When a new compressive load was applied, this element consolidated, producing a vertical strain, ϵ'_z , of 8.5%. The horizontal strain was zero. Compute the volume of water squeezed out of this soil during consolidation and express your answer in liters. (15)

- (b) The thickness of a saturated specimen of clay under a consolidation pressure of 2 kg/cm^2 is 20.70 mm and its water content is 16%. On increase of the consolidation pressure to 4 kg/cm^2 , the specimen thickness decreases by 1.04 mm . Determine the compression index for the soil. The specific gravity of soil is 2.72. (15)

- (c) For a normally consolidated clay, the following values are given: (16 $\frac{2}{3}$)

$$e = e_0 = 1.21 \quad \sigma'_0 = 2 \text{ tsf}$$

$$e_1 = 0.96 \quad \sigma'_0 + \Delta\sigma' = 4 \text{ tsf}$$

The hydraulic conductivity k of the clay for the preceding loading range is $18 \times 10^{-4} \text{ ft/day}$.

- (i) How long in days will it take for a 9-ft thick clay layer (drained on one side) in the field to reach 60% consolidation?
 (ii) What is the settlement at that time (i.e., at 60% consolidation)?

SECTION-B

There are **FOUR** questions in this section. Answer any **THREE**.

5. (a) Explain the followings: (15)

(i) Colloids; (ii) gradation; (iii) dispersion test; (iv) muck; (v) index properties.

(b) Differentiate between organic silt and organic clay. (6)

(c) Draw the flownet for seepage under the structure detailed in Figure 1 and determine the quantity of seepage. The coefficient of permeability of the soil is $5.0 \times 10^{-5} \text{ m/s}$.

What is the uplift force on the base of the structure? (25 $\frac{2}{3}$)

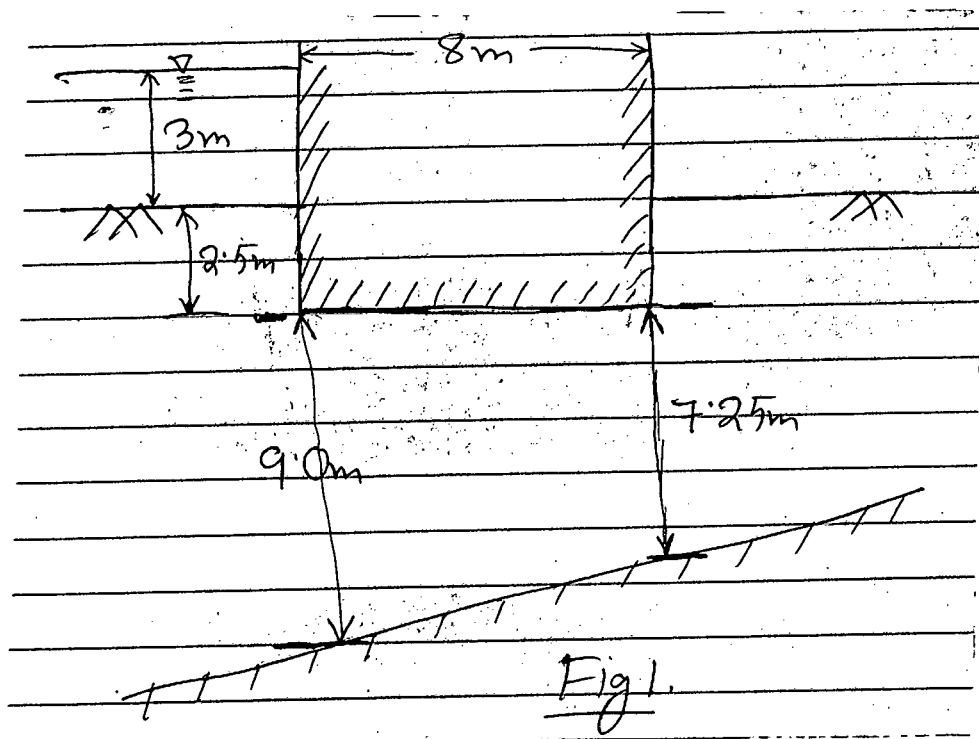

CE 381/WRE

6. (a) Explain the structures and other features of the following three clay minerals with neat sketches, (i) Illite (ii) Kaolinite and (iii) Montmorillonite **(18)**
- (b) Discuss primary and secondary structures of soil aggregates with neat sketches. **(10)**
- (c) Liquid limit test was done on a soil sample using Casagrande's apparatus and the following data were obtained. **(18 $\frac{2}{3}$)**

No. of blows (N)	14	20	24	30	35
Water content%	59	57.5	56.1	53.2	50.7

Plot the flow curve and determine the liquid limit of the soil. Also calculate the value of toughness index, if the plastic limit of the soil is 29%.

7. (a) Explain the following: **(15)**
- (i) Critical hydraulic gradient
 - (ii) Artesian conditions
 - (iii) Surface tension
 - (iv) Sensitivity
 - (v) Thixotrophy
- (b) Draw neatly the plasticity chart according to USCS system showing the classifications of different soil deposits. **(9)**
- (c) Describe the procedure for obtaining vertical pressure at any point below a loaded area. **(6)**
- (d) The plan of a flexible rectangular loaded area is shown in Fig. 2. The uniformly distributed load in the flexible area, $q = 100 \text{ kN/m}^2$. "Determine the increase in the vertical stress, $\Delta\sigma_z$, at a depth of $z = 2 \text{ m}$ below Points A, B and C. **(16 $\frac{2}{3}$)**

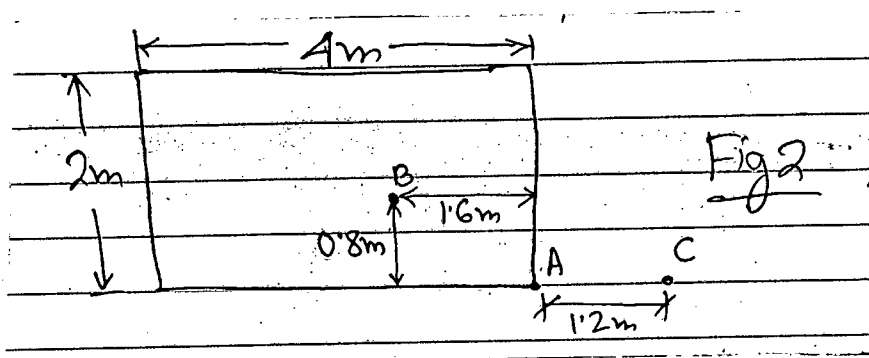

8. (a) Define initial and Secant modulus and represent them through a graph. Also write the relation between Shear and Young's modulus. **(6)**

CE 381/WRE

Contd... Q. No. 8

(b) For a soil, the following results were obtained from grain size distribution and Atterberg limit test:

(12)

% finer No. 200 sieve = 53

LL = 42%; PL = 23%; Classify the soil based on AASHTO Classification system.

(c) An earth embankment diagram is shown in Fig. 3. Determine the stress increase at point A and B due to the embankment load.

(18)

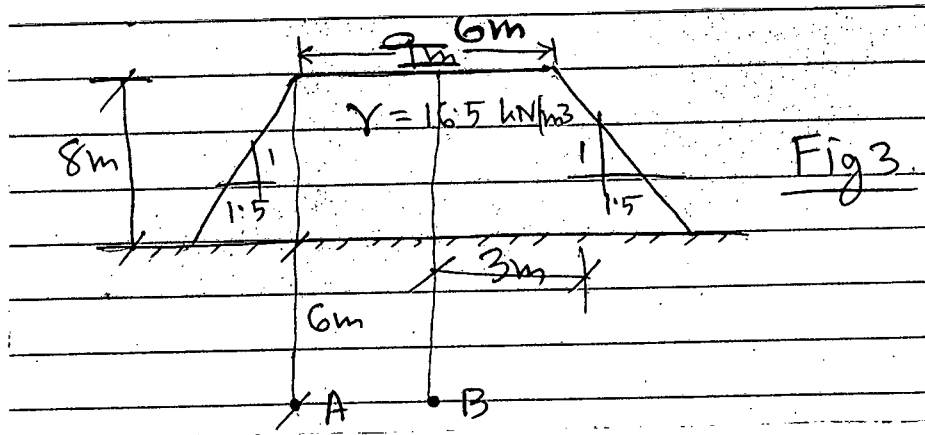

(d) Explain response of loose and dense sand due to shearing with neat sketches.

(10 2/3)

General Classification	Granular Material (35% or less passing No. 200 sieve)							Silt Clay Materials (More than 35% passing No. 200 Sieve)			
	A-1		A-3	A-2				A-4	A-5	A-6	A-7
Group Classification	A-1-a	A-1-b		A-2-4	A-2-5	A-2-6	A-2-7				A-7-5 A-7-6
Sieve Analysis: Percent Passing											
No. 10	50 max	---	---	---	---	---	---	---	---	---	---
No. 40	30 max	50 max	51 min	---	---	---	---	---	---	---	---
No. 200	15 max	25 max	10 max	35 max	35 max	35 max	35 max	36 min	36 min	36 min	36 min
Characteristics of fraction passing No. 40											
Liquid Limit	---	---	---	40 max	41 min	40 max	41 min	40 max	41 min	40 max	41 min
Plasticity Index	6 max		N.P.	10 max	10 max	11 min	11 min	10 max	10 max	11 min	11 min
Usual types of significant constituent materials	Stone Fragments; gravel and sand		Fine sand	Silty or clayey gravel and sand				Silty soils		Clayey soils	
General Rating as Subgrade	Excellent to good							Fair to poor			

- Plasticity index of A-7-5 subgroup is equal to or less than LL minus 30.
- Plasticity index of A-7-6 subgroup is greater than LL minus 30.

Chart 1 AASHTO soil classification system (after Atkins, 1997)

11
6
N

= 7 =

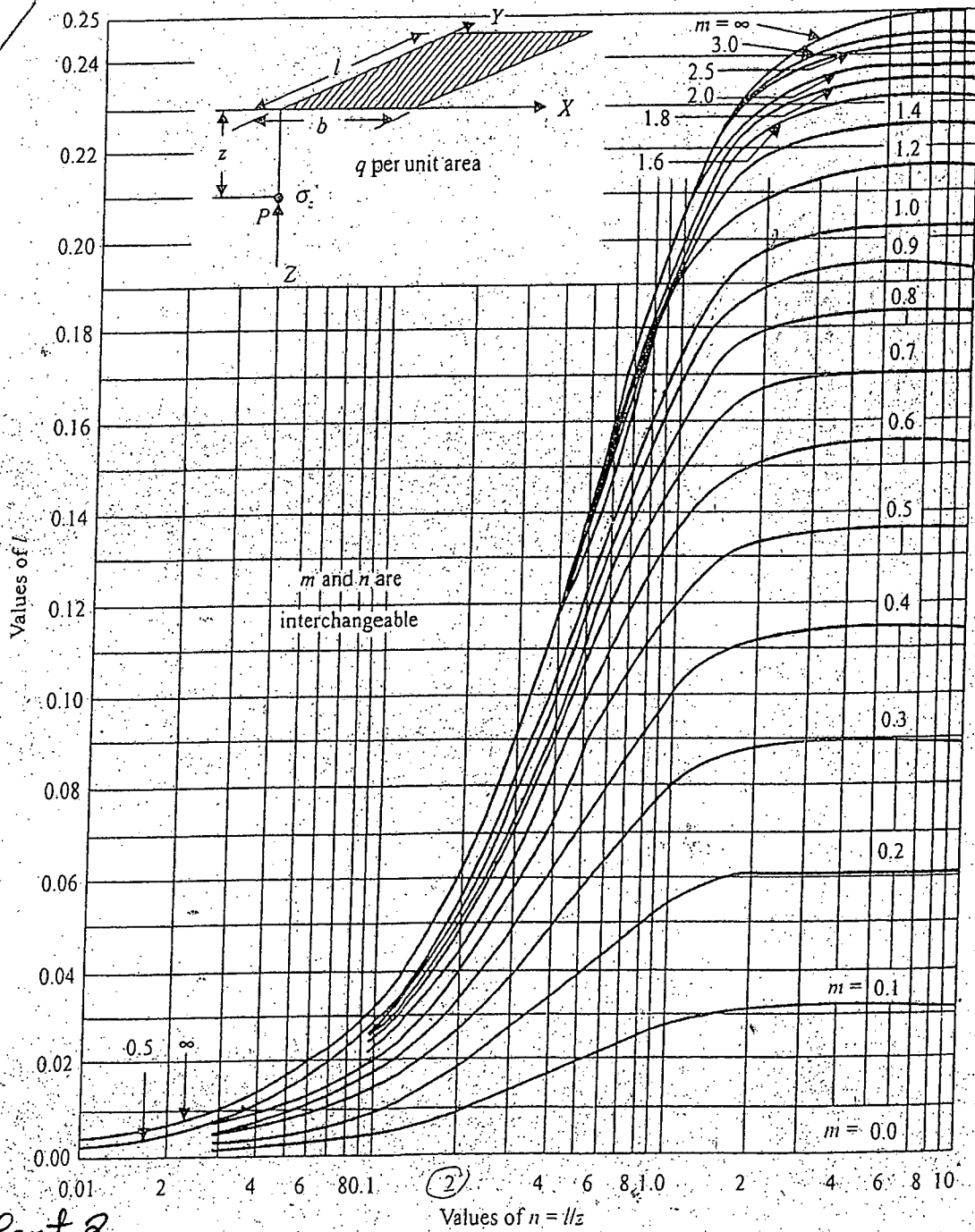
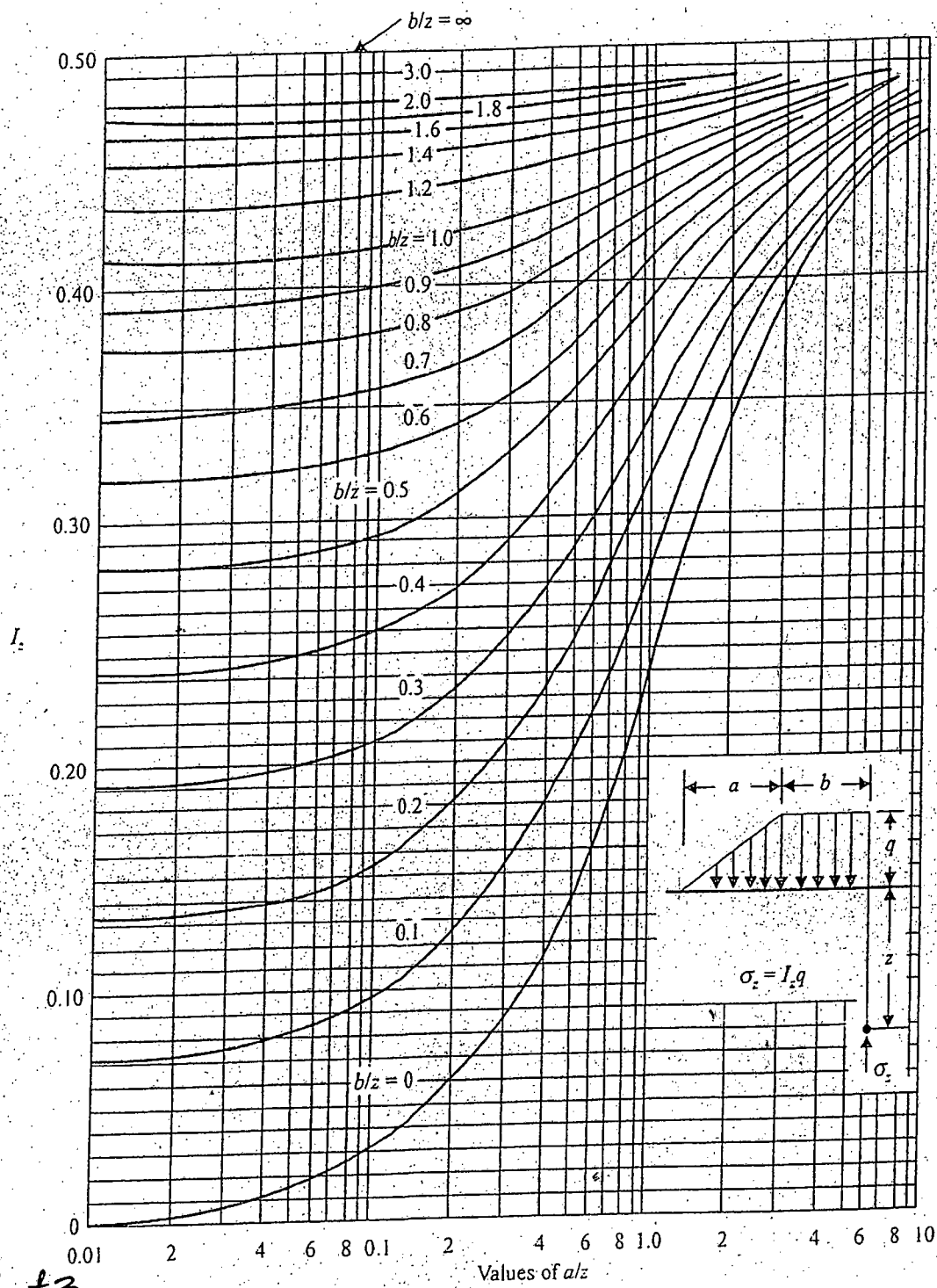

Chart 2

Fadum's chart for obtaining Newmark's influence coefficient, I in terms of m and n .

= 8 =



(Chart 3)

5 Influence coefficient for vertical stress under a long embankment (after Osterberg, 1957).

SECTION – A

There are **FOUR** questions in this section. Answer any **THREE**.

1. (a) What do you know about industrial revolution and capitalism? Describe the social consequences of industrial revolution. (10)
(b) Examine the positive and negative aspects of capitalism in a society. (8)
(c) Critically discuss the Malthusian population theory. (5 1/3)

2. (a) Define environment and pollution. Describe the type of pollution. (8)
(b) Briefly discuss the major pollution issues in Dhaka city. (7 1/3)
(c) What do you mean by green house and green house gases? (8)

3. (a) Define human migration. What are the major effects of rural to urban migration? (8)
(b) What do you mean by social change? Discuss the characteristics of social change. (8)
(c) Write down the different sources of social change in the context of Bangladesh. (7 1/3)

4. Write short notes on any **THREE** of the following: (23 1/3)
(a) Consequences of global warming
(b) Growth of cities
(c) Refuse, reduce, reuse, recycle
(d) Globalization and our life.

SECTION-B

There are **FOUR** questions in this section. Answer any **THREE**.

5. (a) Explain the act of 'drinking a cup of coffee' by using sociological imagination. (13 1/3)
(b) Illustrate the basic steps of scientific research method usually used by social scientists. (10)

HUM 211

6. (a) "When a system of social inequality is based on a hierarchy of groups, sociologists refer to it as stratification" — R.T. Schaefer. Exemplify the statement. **(13 ⅓)**
- (b) In your view, is the extent of social inequality in Bangladesh helpful or harmful to society as a whole? Explain. **(10)**
7. (a) What is deviance? Discuss the social factors that facilitate deviance in society. **(13 ⅓)**
- (b) Point out the advantages and disadvantages of Webers' 'Ideal Type of Bureaucracy'. **(10)**
8. Write short notes on any THREE of the following: **(23 ⅓)**
- (a) Merton's typology of deviance
 - (b) Juvenile delinquency
 - (c) Cyber crime
 - (d) Ascribed status.
-

L-2/T-1/WRE

Date : 09/08/2017

BANGLADESH UNIVERSITY OF ENGINEERING AND TECHNOLOGY, DHAKA

L-2/T-1 B. Sc. Engineering Examinations 2016-2017

Sub : **HUM 213** (Government)

Full Marks: 140

Time : 3 Hours

USE SEPARATE SCRIPTS FOR EACH SECTION

The figures in the margin indicate full marks.

SECTION – A

There are **FOUR** questions in this section. Answer any **THREE**.

1. (a) Make a comparison between society and state. (11 ⅓)
(b) What is nationalism? Discuss the merits and demerits of nationalism. (12)
2. (a) Define sovereignty. Discuss various types of sovereignty with examples. (11 ⅓)
(b) Analyze the political rights and duties of a citizen in a state. (12)
3. (a) Describe the functions of the Legislature in a state. (11 ⅓)
(b) Discuss the modern classification of government with relevant examples. (12)
4. Write short notes on any three (3) of the following: (23 ⅓)
(a) Written Constitution
(b) Dual citizenship
(c) Bicameral legislature
(d) Presidential government

SECTION-B

There are **FOUR** questions in this section. Answer any **THREE** questions.

5. (a) What is the parliamentary form of government? Discuss the differences between the parliamentary and presidential forms of government. (11 ⅓)
(b) Define bureaucracy. Describe the functions of bureaucracy in a democratic state. (12)
 6. (a) Describe different methods of acquiring citizenship. (11 ⅓)
(b) Examine the strength and weakness of the democratic system of government. (12)
 7. (a) Explain the salient features of Bangladesh constitution. (11 ⅓)
(b) Briefly analyze the problems of governance in South Asian countries. (12)
 8. (a) Discuss the importance of Language movement of 1952. (11 ⅓)
(b) Describe the impact of 1970 election on the emergence of Bangladesh. (12)
-

SECTION – AThere are **FOUR** questions in this section. Answer any **THREE**.

1. (a) Solve the following differential equation (10)

$$\frac{dQ}{dt} = k(Q - 70)$$

- (b) Solve the Bernoulli's equation: (15)

$$x^2 \frac{dy}{dx} - 2xy = 3y^4, \quad y(1) = \frac{1}{2}$$

- (c) Solve the following: (10)

$$\frac{dP}{dt} + 2tP = P + 4t - 2$$

2. (a) Determine whether the given differential equation is exact. If it is exact, solve it. (10)

$$(2y \sin x \cos x - y + 2y^2 e^{xy^2}) dx = (x - \sin^2 x - 4xye^{xy^2}) dy$$

- (b) A breeder reactor converts relatively stable uranium-238 into the isotope plutonium-239. After 15 years it is determined that 0.043% of the initial amount
- A_0
- of plutonium has disintegrated. Find the half-life of this isotope if the rate of disintegration is proportional to the amount remaining. (15)

- (c) Solve
- $y = (1 + p)x + p^2$
- where
- $p = \frac{dy}{dx}$
- . (10)

3. (a) Solve the following initial value problem (10)

$$\frac{d^2x}{dt^2} + \omega^2 x = F_0 \sin \omega t, \quad x(0) = 0, x'(0) = 0.$$

- (b) Solve
- $\frac{d^2y}{dx^2} + 2\frac{dy}{dx} - 8y = 2e^{-2x} - e^{-x}$
- ,
- $y(0) = 1, y'(0) = 0$
- . (10)

- (c) Transform the following Cauchy-Euler equation (15)

$$x^2 \frac{d^2y}{dx^2} - 4x \frac{dy}{dx} + 6y = \ln x^2$$

to a differential equation with constant coefficients and hence solve it.

MATH 231/WRE

4. (a) Investigate whether $x = 0$ is an ordinary point, singular point or irregular singular point of the following differential equations. (15)

(i) $x \frac{d^2 y}{dx^2} + (1 - \cos x) \frac{dy}{dx} + x^2 y = 0$

(ii) $(e^x - 1 - x) \frac{d^2 y}{dx^2} + xy = 0$

- (b) Find two linearly independent solutions about $x = 0$ by using method of Frobenius of the differential equation: (20)

$$2x^2 \frac{d^2 y}{dx^2} + 3x \frac{dy}{dx} + (2x - 1)y = 0.$$

SECTION - B

There are **FOUR** questions in this section. Answer any **THREE**.

5. (a) Form a partial differential equation by eliminating the arbitrary function ϕ from $\phi(x + y + z, x^2 + y^2 - z^2) = 0$. (12)

(b) Solve: $x(y^2 + z)p - y(x^2 + z)q = z(x^2 - y^2)$. (12)

(c) Find a complete and singular integrals of $(p^2 + q^2)y = qz$. (11)

6. Solve the following partial differential equation:

(i) $(D^2 + DD' - 6D'^2)z = x^2 \sin(x + y)$. (12)

(ii) $(x^2 D^2 - 2xy DD' + y^2 D'^2 - xD + 3yD')z = 8\sqrt{y/x}$. (12)

(iii) $D(D + D' - 1)(D + 3D' - 2)z = x^2 - 4xy + 2y^2$ (11)

where, $D \equiv \frac{\partial}{\partial x}$, $D' \equiv \frac{\partial}{\partial y}$.

7. (a) Show that $\int_{-1}^1 P_m(x)P_n(x)dx = \begin{cases} 0, & m \neq n \\ \frac{2}{2n+1}, & m = n \end{cases}$ (15).

(b) Express $f(x) = x^4 + 3x^3 - x^2 + 5x - 2$ in terms of Legendre polynomials. (15)

(c) Show that $P_n(-x) = (-1)^n P_n(x)$. (5)

8. (a) Show that $J_n(x)$ is the co-efficient of t^n in the expansion of $e^{\frac{1}{2}x(t-\frac{1}{t})}$ in ascending powers of t . (15)

(b) Show that $J_{\frac{1}{2}}(x) = \sqrt{\frac{2}{\pi x}} \sin x$ (5)

(c) Prove that $J_0(x) = \frac{2}{\pi} \int_0^1 \frac{\cos xt}{\sqrt{1-t^2}} dt$ (15)
