

BANGLADESH UNIVERSITY OF ENGINEERING AND TECHNOLOGY, DHAKA

L-1/T-1 B. Sc. Engineering Examinations 2016-2017

Sub : **PHY 103** (Optics, Waves and Oscillation)

Full Marks : 210

Time : 3 Hours

The figures in the margin indicate full marks.

USE SEPARATE SCRIPTS FOR EACH SECTION

**SECTION – A**There are **FOUR** questions in this Section. Answer any **THREE**.

1. (a) What are nodal points and nodal planes? Draw suitable diagrams showing clearly the cardinal points in relation to (i) a thick lens and, (ii) a system of coaxial thin lenses. (10)
- (b) Show that (i) the distance between the nodal points is equal to the distance between the principal points and, (ii) the principal points and nodal points coincide with one another when the thick lens has the same medium on both sides. (18)
- (c) A thin converging lens and a thin diverging lens are placed coaxially in air at a distance of 5 cm. If the focal length of each lens is 10 cm, find the power and the position of the principal points. (7)
2. (a) Describe with suitable diagram two defects of optical images (i) astigmatism and, (ii) coma. (12)
- (b) What is an aplanatic lens? What are the conditions that must be satisfied for a lens to be aplanatic? (15)
- (c) The focal lengths of a thin convex lens are 100 cm and 96.8 cm for red and blue rays respectively. Calculate the dispersive power of the material of the lens. (8)
3. (a) What is dispersive power of a substance? Deduce the relation,  $\omega = \frac{d\mu}{\mu - 1}$  where the symbols have their usual meanings. (7)
- (b) Show that the magnifying power of a compound microscope is given by, (20)
- $$M = \frac{D(L - f_0 - f_e) + f_e(L - f_0)}{f_e f_0}$$
- where the symbols have their usual meanings.
- (c) Two converging lenses of focal lengths 5 cm and 6 cm form the objective and eyepiece respectively of a compound microscope. The lenses are placed 20 cm apart. Where must an object be placed so that a virtual image is formed at a distance of 25 cm from the eye? (8)

**PHY 103(MME)**

4. (a) Distinguish between simple, damped and forced oscillation. (10)
- (b) What do you mean by “superposition of oscillation”. Derive a general expression for the resultant vibration of a particle simultaneously acted on by two initially perpendicular simple harmonic oscillations having the same frequency but different amplitude and phase angle. Hence show how varying the phase differences different Lissajous figures can be obtained? (20)
- (c) Two simple harmonic oscillations acting simultaneously on a particle are given by  $Y_1 = \sin(\omega t + \pi/2)$  and  $Y_2 = 3 \sin \omega t$ . Find the equation of the resultant vibration. (5)

**SECTION – B**

There are **FOUR** questions in this Section. Answer any **THREE** questions.

5. (a) One of the key features of forced oscillation is that “resonance” is observed during this type of oscillation. Briefly explain the term resonance. Hence derive an expression for the (i) resonant frequency and (ii) resonant amplitude for a particle having mass  $m$  undergoing forced oscillation during steady state. (28)
- (b) A forced damped oscillator of mass  $m$  has a displacement  $x = A \cos (\omega t - \phi)$  and a resistive force  $F = -bv$  (where  $v$  is the velocity of the particle) is acting on it. Find out the instantaneous rate of work done against the resistive force. (7)
6. (a) Define damped oscillation. Establish the differential equation of motion for damped oscillation. (10)
- (b) Solve the differential equation for damped oscillation to obtain an expression for the displacement of the oscillator and hence show how displacement of a damped oscillator varies with time. (18)
- (c) An object of mass 0.2 kg hangs from a spring whose spring constant is 80 N/m. The object is subject to a resistive force given by  $-bv$ , where  $v$  is its velocity and  $b$  is damping constant. If the damped frequency is  $\sqrt{3/2}$  of the undamped frequency, what is the value of the constant  $b$ ? (7)
7. (a) What do you mean by temporal and spatial coherences? Define the term coherence time? (9)
- (b) Using Newton’s experiment, how can you determine the wavelength of light? Discuss in details. (18)

**PHY 103(MME)**

**Contd ... Q. No. 7**

(c) Interference fringes are produced by a Fresnel's biprism in the screen which is 100 cm away from the virtual coherent sources. A lens is interposed between the biprism and the screen, giving two sharp images in two different positions of the lens. If the image lengths (/heights) are 4.05 mm in one position of the lens and 2.90 mm in the other position, determine the fringe separation. (8)

(Given that wavelength of light used is 589.3 nm)

8. (a) Mention the name of the main methods of producing plane polarized light? State Brewster's law. (8)

(b) Discuss the Fraunhofer diffraction due to plane transmission grating and obtain the condition for principal maxima, minima and secondary maxima. (19)

(c) A polarizer and an analyzer are kept parallel so that maximum light is transmitted. When the analyzer is rotated through  $30^\circ$  and  $90^\circ$  respectively, to what percentages of its maximum value of the intensity of transmitted light will be reduced? (8)

-----

**SECTION – A**

There are **FOUR** questions in this Section. Answer any **THREE**.

1. (a) What is the difference between cast iron and wrought iron? How wrought iron is produced? (10+5)  
 (b) When was steel first mass produced? Discuss the changes in steel making technology over the years. (20)
  
2. (a) Show the interrelationship between the four components of the discipline of materials science and engineering. (10)  
 (b) Briefly explain different types of material and their representative characteristics. (20)  
 (c) What do you understand by nanomaterials? (5)
  
3. (a) Classify the fabrication techniques of metals. Describe, with neat sketches, the different types of forming operations. (20)  
 (b) What is powder metallurgy? Discuss the advantages and disadvantages of powder metallurgy over the other methods of fabrication. (15)
  
4. (a) List situations in which casting is the preferred fabrication technique. Compare sand, die, investment and continuous casting techniques. (20)  
 (b) List the nondestructive tests that are generally applied to detect defects. With the aid of sketches discuss how liquid penetrant inspection can be used to detect defects. (15)

**SECTION – B**

There are **FOUR** questions in this Section. Answer any **THREE** questions.

5. (a) For the following unit cell of a hypothetical metal-

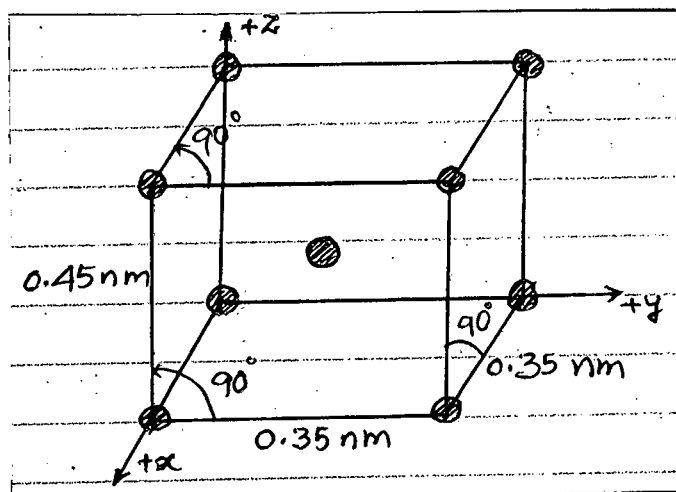

**MME 131**

**Contd ... Q. No. 5(a)**

- (i) To which crystal system does this unit cell belongs? What would this crystal structure be called? (4)
- (ii) Calculate the theoretical bulk density of the material, given that its atomic weight is 141 g/mol. (6)
- (b) What is a F.C.C crystal structure? Give two examples of this structure. With suitable figures, discuss the packing sequence of atoms in F.C.C crystals. (10)
- (c) What is the significance of atomic packing factor? Determine the atomic packing factor for a F.C.C unit cell. (15)
6. (a) "Having a knowledge on ductility of a material is so important". –explain, why? (5)
- (b) Solve the following problems:
- (i) Cylindrical specimen of steel having an original diameter of 12.8 mm is tensile tested to fracture and found to have an engineering fracture strength of 460 MPa. If, its cross-sectional diameter at fracture is 10.7 mm, determine the ductility in terms of percent reduction in area. (5)
- (ii) Aluminium alloy 7075 – T6 is widely used as lightweight but strong material in aircraft and aerospace applications. Its elastic modulus is 70 GPa ( $70 \times 10^9$  Pa) and yield strength is 500 MPa ( $500 \times 10^6$  Pa). Suppose, you take a 50 mm long wire of this sample, stretch it to 50.5 mm and subsequently release the load. What will its final length be approximately? (7)
- (c) Compare the engineering stress-strain diagram for a brittle material and a ductile material. Using necessary figures, explain the changes, a ductile material experiences when tensile loading continues beyond yield point up to fracture. (18)
7. (a) What is a solid solution? For a substitutional solid solution, what are the factors that affect the solubility of the solute in the solvent? (10)
- (b) Classify the crystalline imperfections based on dimensionality. (8)
- (c) What is "edge dislocations"? Briefly, explain the mechanism in which a material deforms based on dislocation movement. (17)
8. (a) What is true stress? Compare true stress-strain behavior with engineering stress strain behavior with the help of necessary figures. (10)
- (b) What is the basic principle to strengthen a metal? Mention the common strengthening mechanisms of metals. (5)
- (c) What are grain boundaries? How do grain boundaries impede dislocation motion? Explain the variation of yield strength with grain size according to Hall-petch relation. (20)
-

BANGLADESH UNIVERSITY OF ENGINEERING AND TECHNOLOGY, DHAKA

L-1/T-1 B. Sc. Engineering Examinations 2016-2017

Sub : **MATH 171** (Calculus and Differential Equation)

Full Marks : 210

Time : 3 Hours

The figures in the margin indicate full marks.

Symbols have their usual meaning.

USE SEPARATE SCRIPTS FOR EACH SECTION

**SECTION – A**There are **FOUR** questions in this Section. Answer any **THREE**.

1. (a) Test the continuity and differentiability of the function

$$f(x) = \begin{cases} (x-a)\sin\frac{1}{x-a}, & x \neq a \\ 0, & x = a \end{cases}$$

at  $x = a$ . Sketch the graph of  $f(x)$ .

(13)

- (b) Evaluate:

$$(i) \lim_{x \rightarrow 1} \frac{\ln \sin\left(\frac{\pi x}{2}\right)}{\sin(x \ln x)} \quad (ii) \lim_{x \rightarrow 2} \left[ \frac{1}{x-2} - \frac{1}{\ln(x-1)} \right]$$

(11+11)

2. (a) Find
- $(y_n)_0$
- for
- $y = \sin(a \sin^{-1} x)$
- (13)

$$(b) \text{ If } w = f\left(\frac{y-x}{xy}, \frac{z-y}{yz}\right) \text{ the show that } x^2 \frac{\partial w}{\partial x} + y^2 \frac{\partial w}{\partial y} + z^2 \frac{\partial w}{\partial z} = 0$$
 (11)

- (c) A closed cylindrical can has a capacity of 1 liter. How should we choose the height and radius to minimize the amount of material required to produce the can? (11)

3. (a) Prove that all the points of the curve
- $y^2 = 4a \left[ x + a \sin\left(\frac{x}{a}\right) \right]$
- at which the tangent is

parallel to the  $x$ -axis lie on a parabola. (18)

- (b) Find the angle of intersection of the curves
- $r = a(1 + \cos\theta)$
- and
- $r = a(1 - \cos\theta)$
- . (17)

4. Workout the following:

$$(a) \int \frac{dx}{x^3(a+bx)^2}$$
 (11)

$$(b) \int \sqrt{1 + \sec x} dx$$
 (12)

$$(c) \int \frac{x^3 + 2x^2 + x + 7}{\sqrt{x^2 + 2x + 3}} dx$$
 (12)

**MATH 171(MME)****SECTION – B**

There are **FOUR** questions in this Section. Answer any **THREE**.

5. (a) Find the limit when  $n \rightarrow \infty$  of the series  $\frac{1}{1+n^3} + \frac{2^2}{2^3+n^3} + \frac{3^2}{3^3+n^3} + \dots + \frac{n^2}{n^3+n^3}$  (11)

(b) Evaluate:  $\int_0^{16} \frac{x^{\frac{1}{4}}}{1+x^{\frac{1}{2}}} dx$  (12)

(c) Evaluate:  $\int_0^{\frac{\pi}{2}} \ln \sin x dx$  (12)

6. (a) Find the area common to the curve  $y^2 = 4ax$  and  $x^2 = 4ay$ . (15)

(b) Find the volume and surface of the solid of revolution respectively by the curve  $r = a(1 - \cos \theta)$  about the initial line. (20)

7. (a) Form the differential equation from the equation  $y = e^x(A \cos x + B \sin x)$ , where  $A$  and  $B$  are arbitrary constants (11)

(b) Solve:  $(2\sqrt{xy} - y)dx - xdy = 0$  (12)

(c) Solve:  $(y^4 + 2y)dx + (xy^3 + 2y^4 - 4x)dy = 0$  (12)

8. Solve the following:

(a)  $(D^2 - 4D + 13)y = 0$ ,  $y(0) = -1$ ,  $y'(0) = 2$ . (8)

(b)  $(D^3 + D^2 - D - 1)y = \cos 2x + e^x$ . (12)

(c)  $\frac{d^2y}{dx^2} - 6\frac{dy}{dx} + 9y = x^2 e^{3x} \cos 2x$ . (15)

-----

**SECTION – A**

There are **FOUR** questions in this Section. Answer any **THREE**.

The symbols have their usual meanings.

1. (a) Given that  $V_1 = 10 \sin(\omega t)$  V, the current flowing through the inductor is  $-j2$  A and the current flowing through the RC branch is  $3\angle 45^\circ$  A. The product of values of L and C is  $10^{-9}$ . Find the operating frequency ( $\omega$ ) of the voltage source at this condition. At which frequency, the power factor of the load will be unity? (10+10)

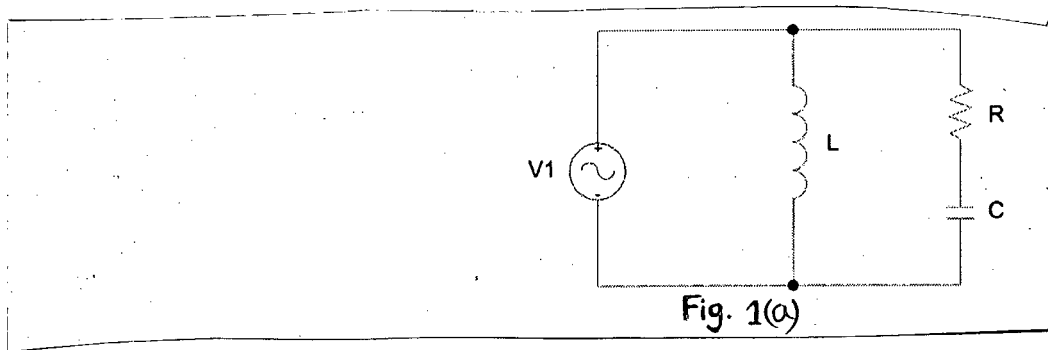

- (b) If the current  $i(t)$  A flows through a  $9 \Omega$  resistor, calculate the average power absorbed by the resistor. (15)

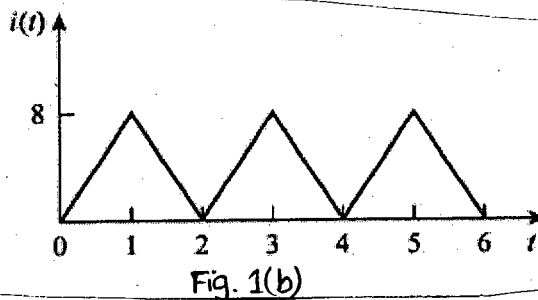

2. (a) Show that a purely reactive load (L/C) absorbs power in a half cycle and returns that power in the next half cycle. (10)
- (b) Power that all forms of ac power are conserved. (10)
- (c) Assume that a load is being fed by a voltage source through a transmission line. The load impedance is  $(15-10j) \Omega$  and the transmission line impedance is  $(4 + 2j) \Omega$ . The rms value of the voltage source is 220 V. Find the power absorbed by the load impedance. For maximum power at load, what should be the value of line impedance? (15)



**EEE 155(MME)**

3. (a) Determine the current  $I$  in the circuit of Fig. for Q. No. 3(a).

(10)

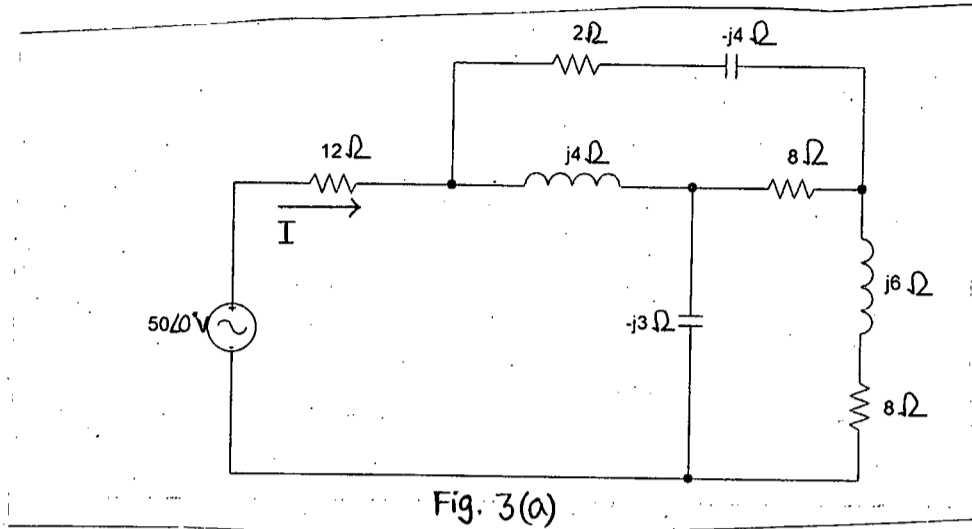

(b) When connected to a 120 V (rms), 60 Hz power line, a load absorbs 4 kW at a lagging power factor of 0.8. Find the value of capacitance necessary to raise the pf to 0.95.

(10)

(c) Determine the phase difference between  $I$  and  $I_1$  in the circuit of Fig. for Q. No. 3(c).

Given that  $Z_1 = (20 - 40j) \Omega$  and  $Z_2 = (10 + 10j) \Omega$ .

(15)

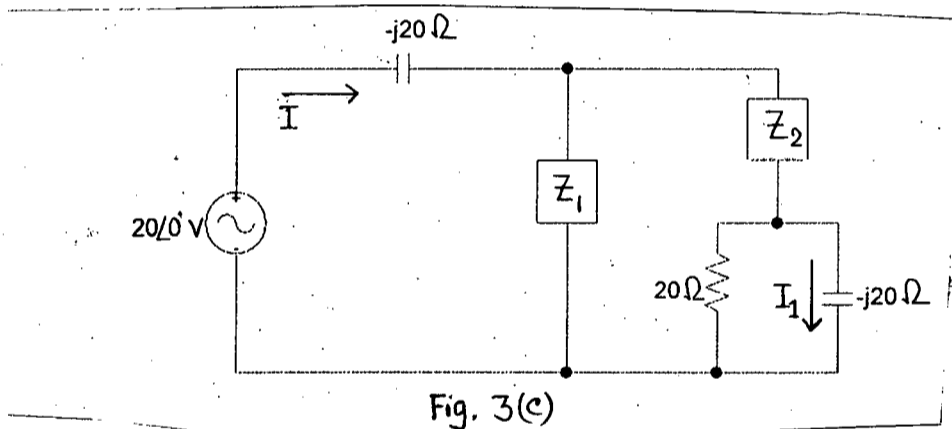

4. (a) For the series parallel magnetic circuit of Fig. for Q. No. 4(a), find the value of  $I$  required to establish a flux in the gap of  $\Phi_g = 2 \times 10^{-4}$  Wb. Neglect fringing.

(20)

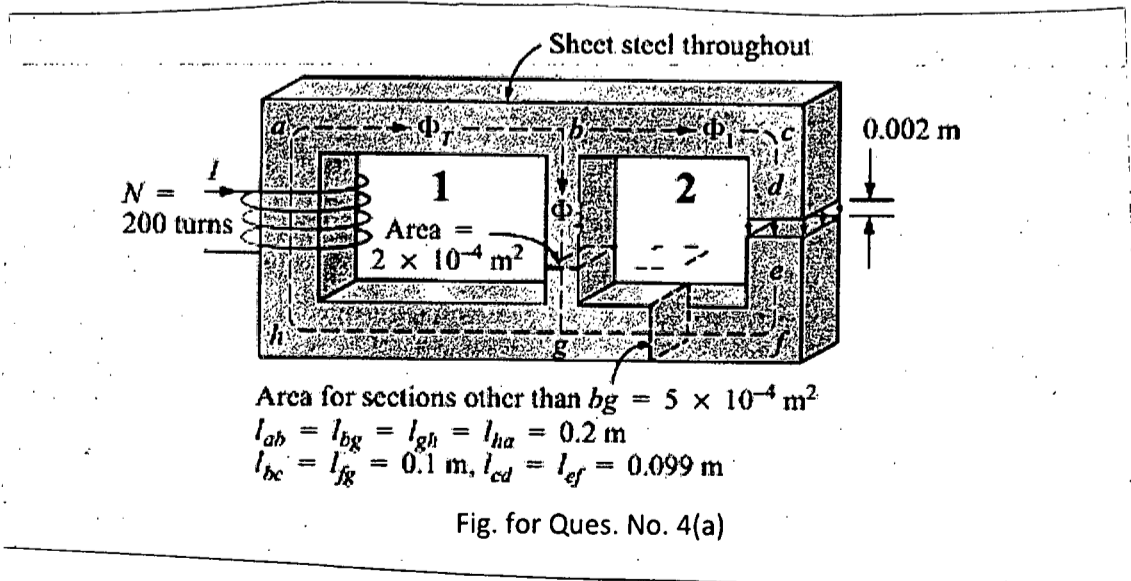

**EEE 155(MME)**

**Contd ... Q. No. 4**

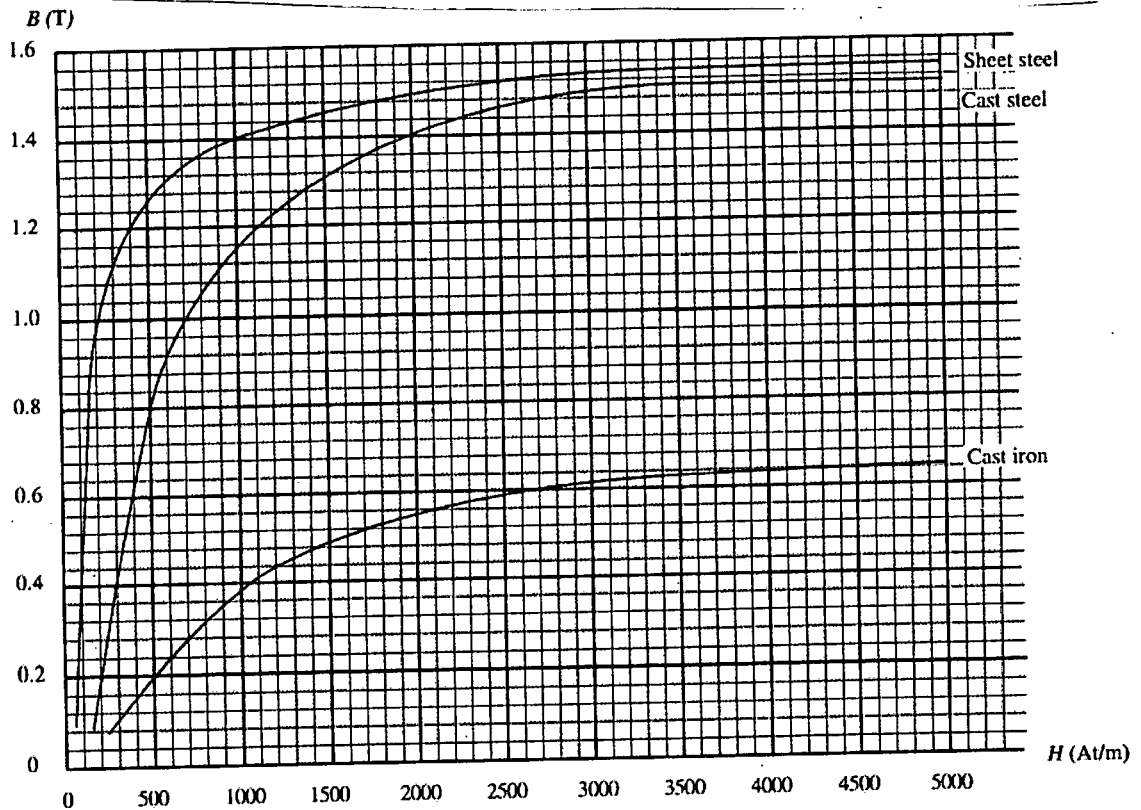

**Magnetization Curve**

(b) A series connected load draws a current  $i(t) = 4 \cos(100 \pi t + 10^\circ)$  A when the applied voltage is  $v(t) = 120 \sin(100 \pi t + 20^\circ)$  V. Find the apparent power and the power factor of the load. Determine the element values that form the series-connected load. (15)

**SECTION – B**

There are **FOUR** questions in this Section. Answer any **THREE** questions.

5. (a) A Y-network consists of 3 resistances called  $R_1, R_2$  and  $R_3$ . If it is transformed into a Delta network, derive the expression of involved resistances. (20)

(b) Find the equivalent resistance  $R_{EQ}$  for the following network. (15)

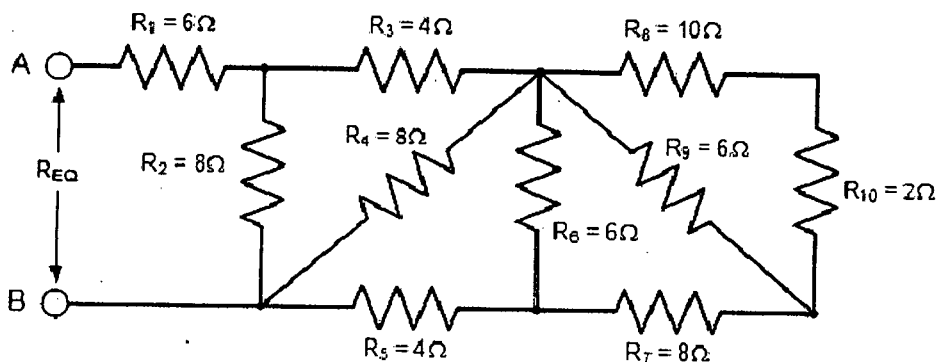
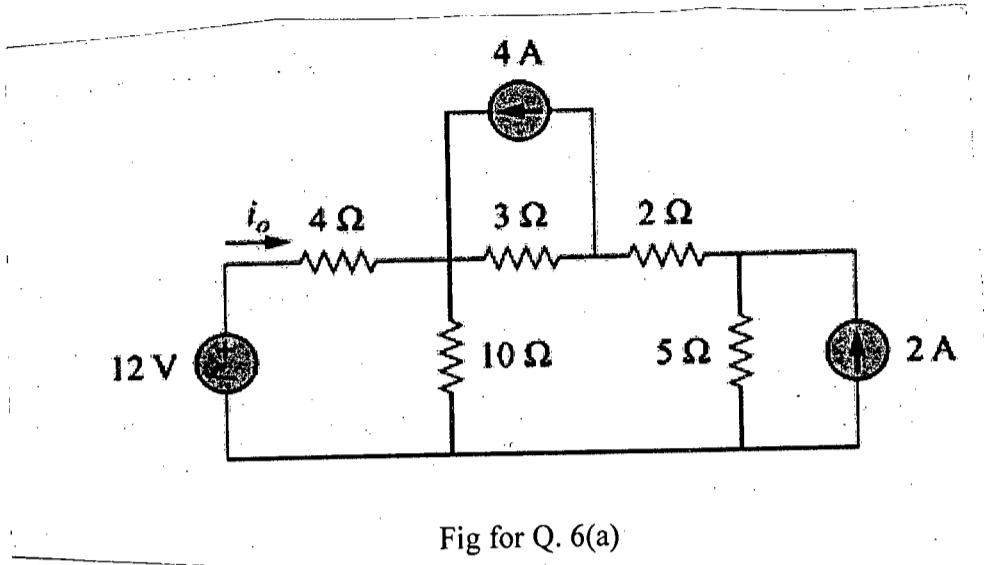

Fig for Q. 5(b)

**EEE 155(MME)**

6. (a) Find  $i_o$  in the following circuit using techniques of nodal analysis. (17)



- (b) Find the Norton's equivalent circuit at terminal a-b. (18)

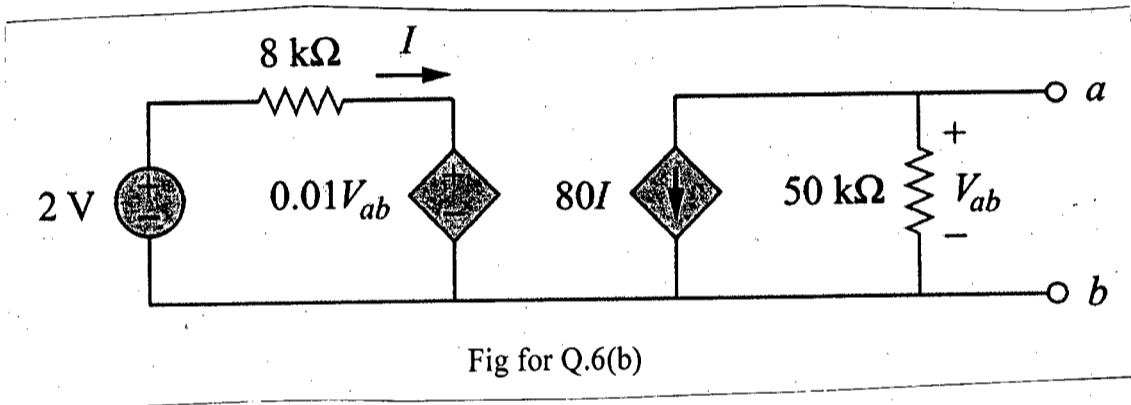

7. (a) Find voltage across the 5A current source in the following circuit using techniques of mesh analysis. (18)

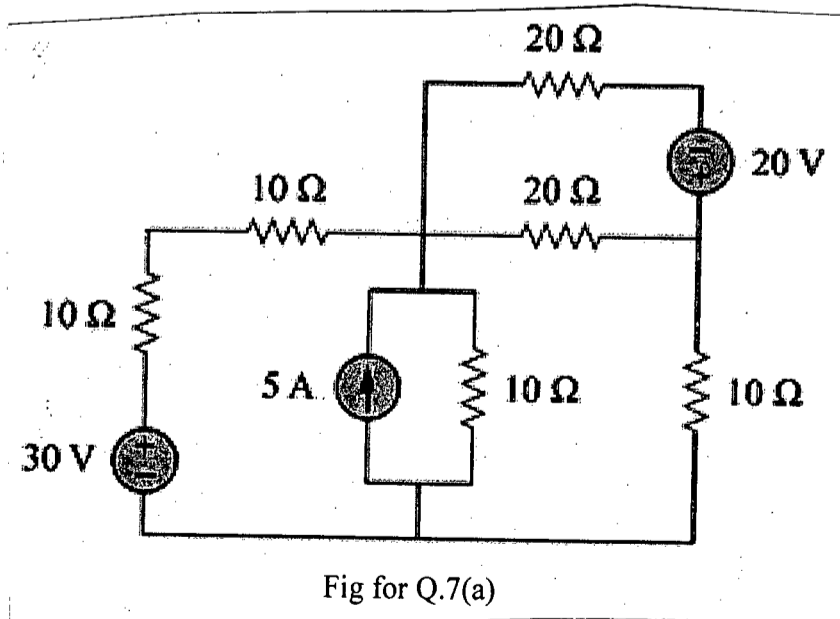

$\frac{5}{5}$   
= 1 =

**EEE 155(MME)**

**Contd ... Q. No. 7**

(b) Find Thevenin's equivalent voltage and resistance for the following circuit at a-b. (17)

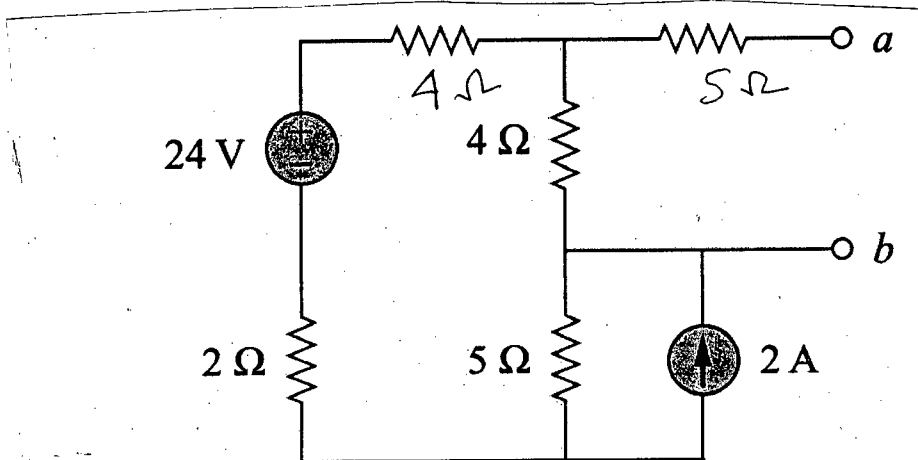

Fig for Q.7(b)

8. (a) Find  $V_0$  in the following circuit using techniques of superposition. (20)

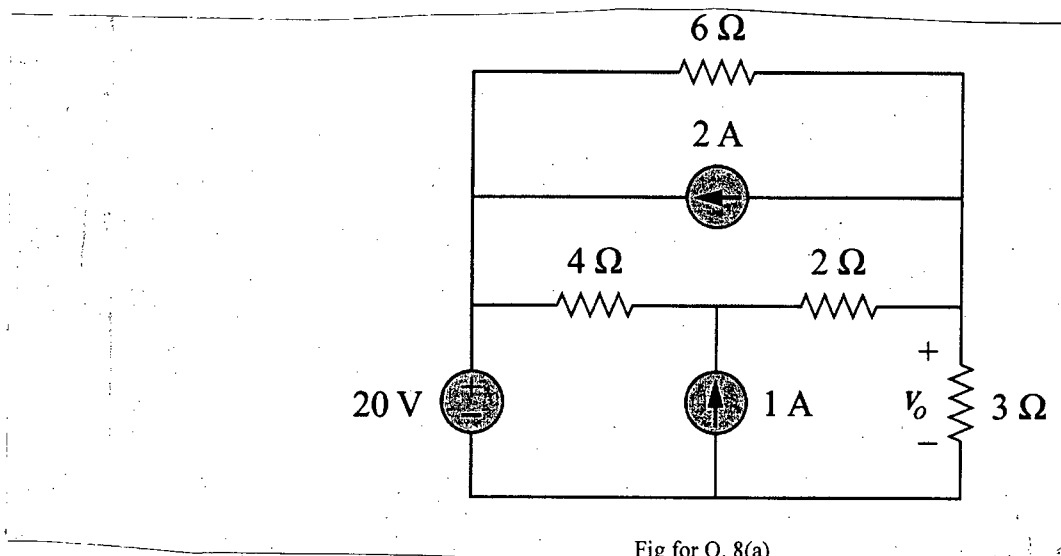

Fig for Q. 8(a)

(b) Find the value of  $R$  that ensures maximum power transfer to the 10 Ω resistance in the following circuit. (15)

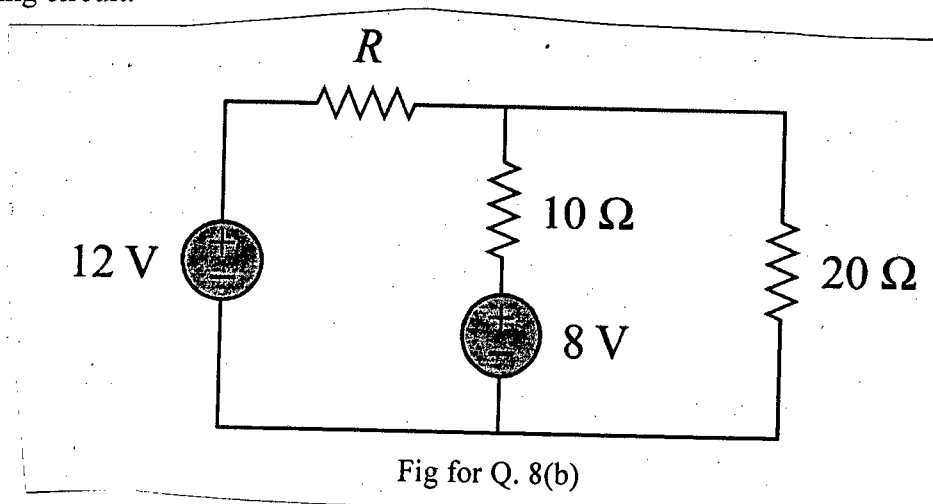

Fig for Q. 8(b)

BANGLADESH UNIVERSITY OF ENGINEERING AND TECHNOLOGY, DHAKA

L-1/T-1 B. Sc. Engineering Examinations 2016-2017

Sub : **CHEM 107** (Inorganic and Physical Chemistry)

Full Marks : 210

Time : 3 Hours

The figures in the margin indicate full marks.

USE SEPARATE SCRIPTS FOR EACH SECTION

**SECTION – A**There are **FOUR** questions in this Section. Answer any **THREE**.

Assume reasonable values for any missing data.

1. (a) Define rate of reaction. How does it differ from rate of conversion? Explain how you can determine the order of a reaction using differential rate equation. (12)
- (b) Derive an expression for the rate constant of a first order reaction. What are the characteristic features of such reactions? (13)
- (c) At 100°C, the half-life for the thermal decomposition of N<sub>2</sub>O<sub>5</sub> is 4.6 s and is independent of initial pressure of N<sub>2</sub>O<sub>5</sub>. Calculate the rate constant of the reaction at this temperature. (10)
2. (a) What are reversible and irreversible cells? How can you determine the equilibrium constant of a reaction from emf measurement? (12)
- (b) Deduce Van't Hoff equation for the variation of equilibrium constant with temperature. How can you predict the exothermic and endothermic nature of reactions from the expression? (13)
- (c) The equilibrium constant for the reaction  $\text{H}_2(\text{g}) + \text{S}_2(\text{g}) \rightleftharpoons 2\text{H}_2\text{S}(\text{g})$  is 20.2 atm at 945°C and 9.21 atm at 1065°C. Calculate the heat of reaction. (10)
3. (a) What are colligative properties? Explain how vapor pressure and boiling point of a solvent vary due to the addition of non-volatile and non-electrolyte solutes. (12)
- (b) Derive a relation between the elevation of the boiling point of the solution and the molecular weight of the solute. (13)
- (c) A solution prepared from an unknown non-volatile solute in 30.0 g of CCl<sub>4</sub>, boils at 350.392 K. Calculate the molar mass of the solute. The boiling point of CCl<sub>4</sub> and its K<sub>b</sub> are 350.0 K and 5.03 K .mol<sup>-1</sup>, respectively. (10)
4. (a) State and explain Nernst distribution law. How is the law modified when the solute undergoes association in one of the solvent? (12)
- (b) What is buffer solution? How does it resist the change in its pH upon addition of small quantities of strong acids or bases? (13)
- (c) What will be the pH of a solution obtained by mixing 5 g of acetic acid and 7.5 g of sodium acetate and making the volume to 500 ml? (For acetic acid K<sub>a</sub> = 1.8 × 10<sup>-5</sup> at 25°C) (10)

**CHEM 107(MME)**

**SECTION – B**

There are **FOUR** questions in this Section. Answer any **THREE** questions.

5. (a) Write Schrödinger equation for hydrogen atom and explain each term involved in it. (5)  
(b) The acceptable solution to the Schrödinger wave equation must have four spectral properties. What are these? (6)  
(c) Draw radial probability distribution curve for the atomic orbital with principal quantum number,  $n = 3$  and azimuthal quantum number,  $l = 1$  and explain the curve. (12)  
(d) Discuss photoelectric effect. What conclusion do you draw from it? (12)
6. (a) The simultaneous determination of the velocity and position of a macroscopic particle in flight can be precisely carried out; no such precision is possible for an electron, why? (10)  
(b) Calculate the frequency of the line in the emission spectrum of hydrogen when the atoms of the gas contain electrons in the 3rd energy level. (5)  
(c) Write a note on “de-Broglie’s equation. (10)  
(d) Atomic radii of the element in a series in the periodic table decreases with increasing atomic number upto VII group, but increase in inert gases, Explain giving reasons. (10)
7. (a) Define screening effect? Calculate the screening constant of silicon using Slater’s rules. (5)  
(b) Define electron affinity. Discuss the trends in their variation in a group and a period of the periodic table. (10)  
(c) The formation of  $F^-(g)$  ion from  $F(g)$  atom is exothermic whereas that of  $O^{2-}(g)$  ion from  $O(g)$  is endothermic. Explain. (5)  
(d) What are sigma and pi molecular orbitals? Give their characteristics. (5)  
(e) Hydrogen forms diatomic molecule and helium remains monoatomic. – Explain it on the basis of molecular orbital theory. (10)
8. (a) What is hybridization? Discuss  $Sp^3d^2$  hybridization with a suitable example. (10)  
(b) Explain why the shapes of  $ClO_4^-$  and  $ClO_3^-$  ions are different, although they have the same number of electron pairs around Cl-atom. (8)  
(c) Write a Lewis formula for each of the following molecules and then obtain the formal charges of the (i)  $O_3$  (ii)  $CO$  (iii)  $HNO_3$  (10)  
(d) In  $SiCl_4$ ,  $PCl_3$  and  $SCl_2$  molecules the bond angle is a decreasing trend. – Explain giving reasons. (7)
-