

The figures in the margin indicate full marks.

Assume reasonable values for missing data, if any.

USE SEPARATE SCRIPTS FOR EACH SECTION

SECTION – A

There are **FOUR** questions in this section. Answer any **THREE**.

1. (a) What are the materials for civil engineering constructions? Define standard, specification and test method. Show a typical specification of aggregates mentioning at least three properties. (15)
- (b) What are the strength tests of aggregates and strength and durability tests of stones? (10)
- (c) Differentiate between fineness modulus (F.M.) and grading of an aggregate mix. Find the F.M. of a sand sample from the following sieve analysis data. (10)

Sieve size, mm	9.5	4.75	2.36	1.40	1.18	0.60	0.30	0.15	0.075	PAN
Amount retained, gm	0	6.0	10.7	23.0	59.1	90.9	45.1	45.0	17.0	3.2

2. (a) What are the factors affecting the properties of concrete? Why and how does the concrete strength vary? (15)
- Design a concrete mix by the 'minimum Voids Method' from the following data:
 Voids in coarse aggregate = 45 percent; Voids in fine aggregate = 30 percent;
 Allowances for cement = 12 percent; Allowances for fine aggregates = 10 percent.
- (b) What are the factors affecting workability of fresh concrete? How is the workability measured by slump test? (10)
- (c) What are the stages in the British method of concrete mix design? Mix design results as per British method are as follows: (10)

For 1 m³ of fresh concrete,

$$\text{Water} = 190 \text{ kg/m}^3$$

$$\text{Cement} = 405 \text{ kg/m}^3$$

$$\text{Find Aggregate} = 630 \text{ kg/m}^3$$

$$\text{Coarse Aggregate} = 1165 \text{ kg/m}^3$$

If the absorption of fine and coarse aggregates are 2 and 1 percent respectively, find the quantities of the ingredients considering oven-day aggregates for a trial mix for casting nine 100 mm cubes.

CE 201

- 8. (a) What does ferrocement repair do? With neat sketch, show the step by step method of repairing spalled slab using ferrocement. (15)
- (b) Write down the characteristics of elastic strain, plastic strain and viscous strain. (10)
- (c) For the loading history shown in Figure 1, draw the probable strain response for an elasto-visco-plastic material. Consider equal time interval. (10)

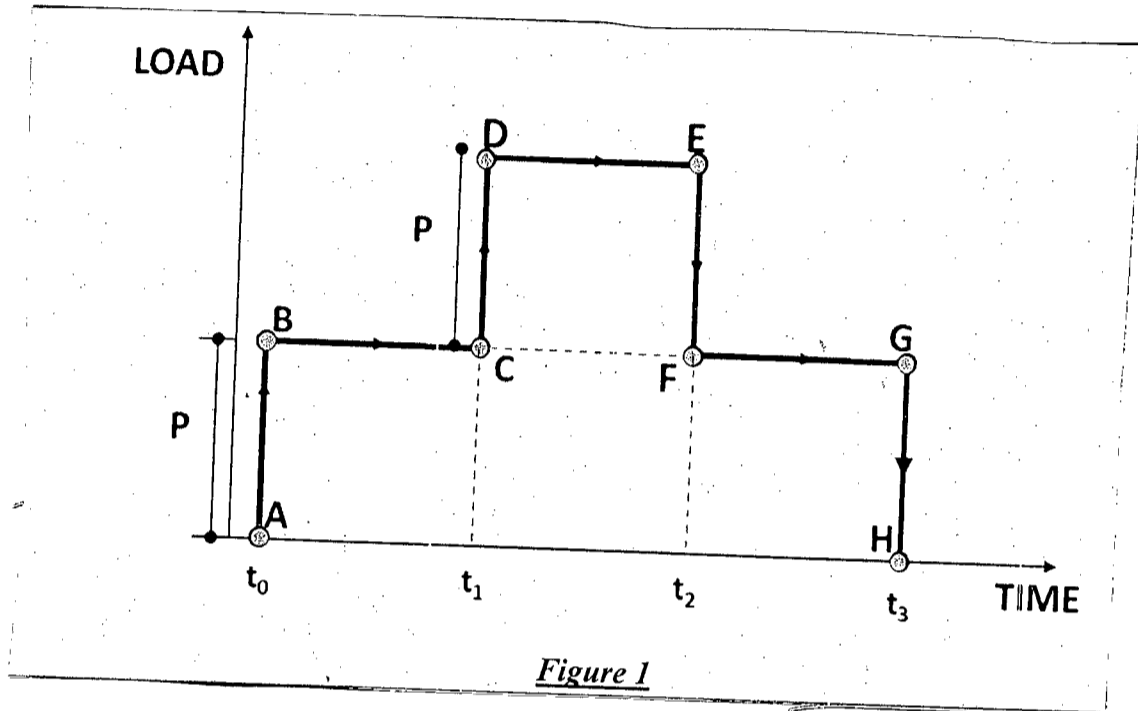

BANGLADESH UNIVERSITY OF ENGINEERING AND TECHNOLOGY, DHAKA

L-2/T-2 B. Sc. Engineering Examinations 2015-2016

Sub : **CE 207** (Applied Mathematics for Engineers)

Full Marks: 210

Time : 3 Hours

USE SEPARATE SCRIPTS FOR EACH SECTION

The figures in the margin indicate full marks. Symbols used have their usual meaning.

SECTION – A

There are **FOUR** questions in this section. Answer any **THREE**.

Assume reasonable value for any missing data. Symbols carry their usual meaning.

1. (a) A stone falls down from a leaning tower under gravitational force from rest and gradually accelerates to a velocity $v(t)$ in air. Explain the phenomenon and identify the factors affecting the fall. List the variables and identify the dependent and independent variables. (20)
 - (b) What will be the changes in formulation in the problem mentioned in 1(a) if the stone is thrown as a projectile with a uniform velocity v_0 and at angle α with the horizon? (15)
 2. (a) Differentiate between Implicit Solution and Explicit Solution. (5)
 - (b) What is indicial equation? Derive it from Bessel's equation. (10)
 - (c) What is the fundamental condition for existence of a power series solution of an equation? (10)
 - (d) Apply power series method and solve the following different equation: (10)
- $$y' - y = 0.$$
3. (a) List and explain the valid operations on power series. (15)
 - (b) What is "Remainder"? (10)
 - (c) Write a short note on "Orthogonality" of Legendre Polynomials. (10)
 4. (a) If X_1, X_2, \dots, X_n are independent Poisson random variables, each having mean λ , determine the maximum likelihood estimator of λ . Derive the expression. (10)
 - (b) Bessel's equation is a special form of Frobenius equation. Explain with an example. (5)
 - (c) Apply appropriate method to solve the following different equation. (20)

$$(1 + x)y' = y.$$

CE 207**Contd... Q. No. 5****SECTION-B**

There are **FOUR** questions in this section. Answer any **THREE** questions.

Table for Fourier Transforms.

5. A rotatory vibrating machine exerts perfect sinusoidal force $p(t) = 200 \sin \frac{\pi}{2} t$ kg. Determine the motion of the mass governed by the equation of motion of a damped simple oscillator given below. (35)

$$m\ddot{u} + c\dot{u} + ku = p(t)$$

where $m = 10$ kg, $c = 2$ kg/s and $k = 100$ kg/s².

6. (a) Determine if the following functions are periodic or non-periodic. If periodic, then find the fundamental periods. Find the even and odd parts of the functions. (15)

(i) $\frac{x}{x+2}$ (ii) $\sin^2 x$ (iii) $6 \cos x - 4 \sin 3x$ (iv) $e^{\sin 3x}$.

- (b) Determine the Fourier Integral representation of $f(x) = e^{-|x|}$. (20)

7. (a) Express the following periodic half sine pulse (Fig.1) by a Fourier Series. (17)

(b) A gas pipe line of flexural rigidity EI is overlain with soil. The soil is, however, not uniformly distributed. Distribution and the force due to the overburden soil is shown in Fig.2. Underneath the pipeline the soil is compacted. Stiffness of underneath soil is "k". Determine the vertical deformation of the pipeline due to overlying loose soil.

Governing equation is given by, (18)

$$EIu^{IV} + ku = p(x)$$

8. (a) Evaluate Fourier transform of $f(x) = \frac{x-a}{x^2+a^2}$. (15)

(b) Evaluate the following: (20)

(i) $F^{-1}\left\{(\omega+3)e^{-4(\omega+3)^2}\right\}$ (ii) $F^{-1}\left\{e^{-|\omega|}\cos\omega\right\}$.

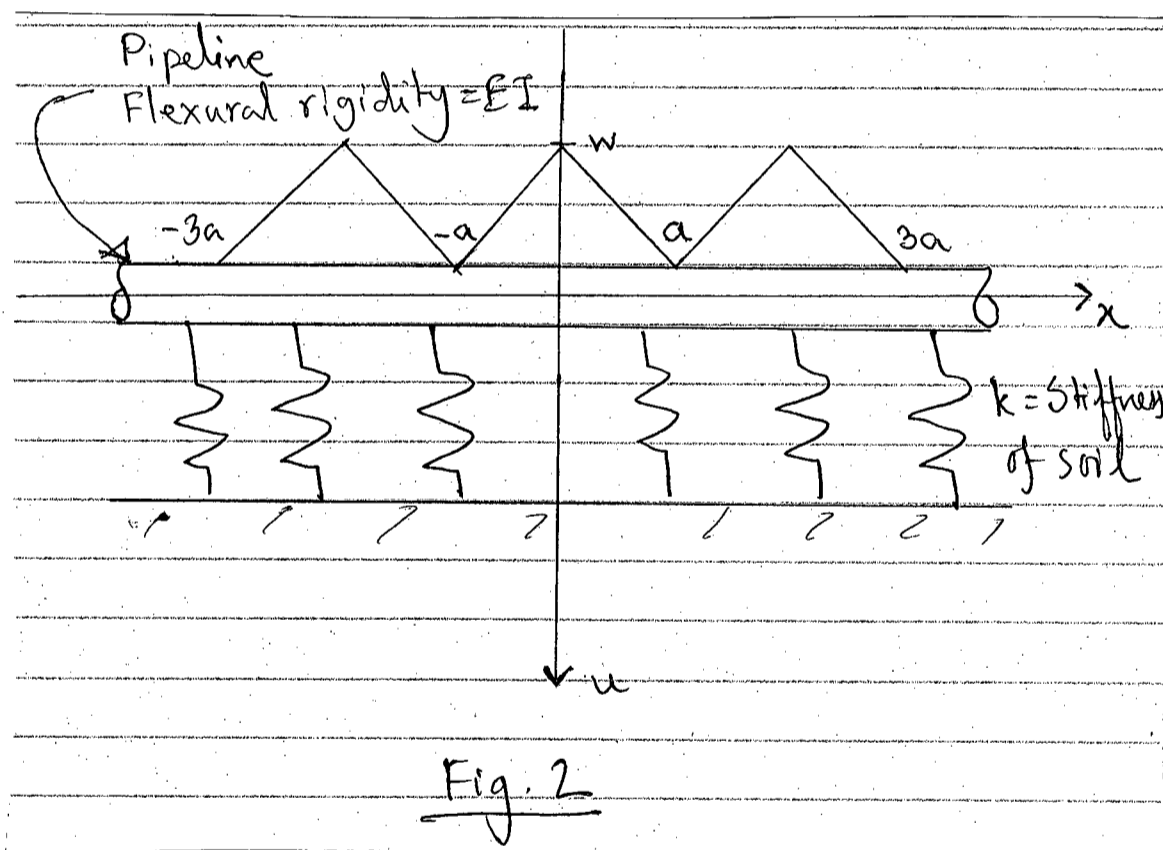
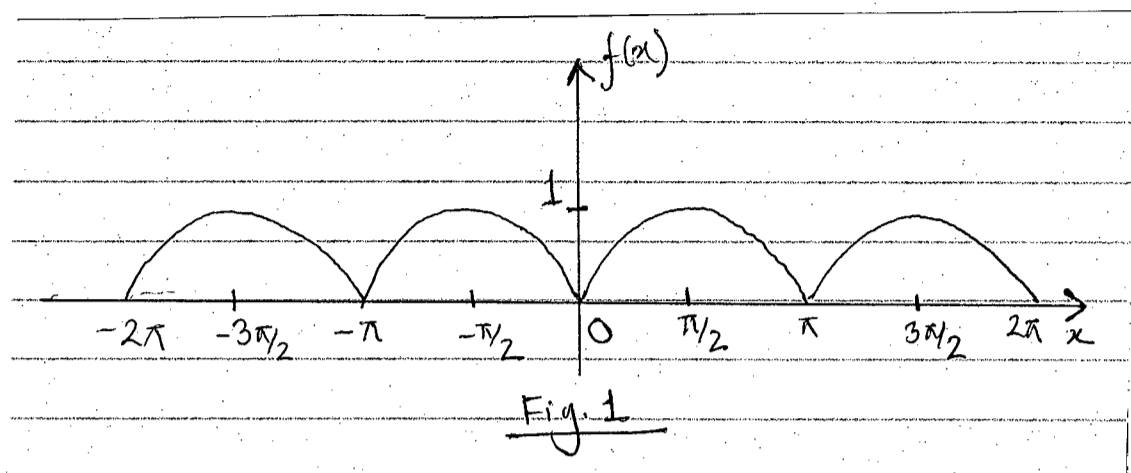

Table of Fourier Transforms

$f(x)$	$\hat{f}(\omega) = \int_{-\infty}^{\infty} f(x)e^{-i\omega x} dx$
1. $\frac{1}{x^2 + a^2} \quad (a > 0)$	$\frac{\pi}{a} e^{-a \omega }$
2. $H(x)e^{-ax} \quad (\operatorname{Re} a > 0)$	$\frac{1}{a + i\omega}$
3. $H(-x)e^{ax} \quad (\operatorname{Re} a > 0)$	$\frac{1}{a - i\omega}$
4. $e^{-a x } \quad (a > 0)$	$\frac{2a}{\omega^2 + a^2}$
5. e^{-x^2}	$\sqrt{\pi} e^{-\omega^2/4}$
6. $\frac{1}{2a\sqrt{\pi}} e^{-x^2/(2a)^2} \quad (a > 0)$	$e^{-a^2\omega^2}$
7. $\frac{1}{\sqrt{ x }}$	$\sqrt{\frac{2\pi}{ \omega }}$
8. $e^{-a x /\sqrt{2}} \sin\left(\frac{a}{\sqrt{2}} x + \frac{\pi}{4}\right) \quad (a > 0)$	$\frac{2a^3}{\omega^4 + a^4}$
9. $H(x+a) - H(x-a)$	$\frac{2 \sin \omega a}{\omega}$
10. $\delta(x-a)$	$e^{-i\omega a}$
11. $f(ax+b) \quad (a > 0)$	$\frac{1}{a} e^{i\omega b/a} \hat{f}\left(\frac{\omega}{a}\right)$
12. $\frac{1}{a} e^{-ibx/a} f\left(\frac{x}{a}\right) \quad (a > 0, b \text{ real})$	$\hat{f}(a\omega + b)$
13. $f(ax) \cos cx \quad (a > 0, c \text{ real})$	$\frac{1}{2a} \left[\hat{f}\left(\frac{\omega - c}{a}\right) + \hat{f}\left(\frac{\omega + c}{a}\right) \right]$
14. $f(ax) \sin cx \quad (a > 0, c \text{ real})$	$\frac{1}{2ai} \left[\hat{f}\left(\frac{\omega - c}{a}\right) - \hat{f}\left(\frac{\omega + c}{a}\right) \right]$
15. $f(x+c) + f(x-c) \quad (c \text{ real})$	$2\hat{f}(\omega) \cos \omega c$

$$f(x)$$

$$\hat{f}(\omega) = \int_{-\infty}^{\infty} f(x)e^{-i\omega x} dx$$

$$16. f(x+c) - f(x-c) \quad (c \text{ real})$$

$$2i\hat{f}(\omega) \sin \omega c$$

$$17. x^n f(x) \quad (n = 1, 2, \dots)$$

$$i^n \frac{d^n}{d\omega^n} \hat{f}(\omega)$$

Linearity of transform and inverse:

$$18. \alpha f(x) + \beta g(x)$$

$$\alpha \hat{f}(\omega) + \beta \hat{g}(\omega)$$

Transform of derivative:

$$19. f^{(n)}(x)$$

$$(i\omega)^n \hat{f}(\omega)$$

Transform of integral:

$$20. f(x) = \int_{-\infty}^x g(\xi) d\xi,$$

where $f(x) \rightarrow 0$ as $x \rightarrow \infty$

$$\hat{f}(\omega) = \frac{1}{i\omega} \hat{g}(\omega)$$

Fourier convolution theorem:

$$21. (f * g)(x) = \int_{-\infty}^{\infty} f(x - \xi)g(\xi) d\xi$$

$$\hat{f}(\omega)\hat{g}(\omega)$$

SECTION – A

There are **FOUR** questions in this section. Answer any **THREE**.

1. (a) Briefly state various applications of Geology. Discuss in detail with examples how Geology helps in the prediction of natural hazards. (16)
 (b) Show how geological time is divided into various era and period. Mention time of start of each era. Briefly discuss the most recent era. (11)
 (c) What do you mean by fossils? Where do you find them? How do you determine their age? (8)

2. (a) Briefly describe different principles of geological formation. Present neat sketches where applicable. (11)
 (b) Distinguish between the following with figure and examples where applicable (answer any four): (6×4=24)
 - (i) Contact metamorphism and Regional metamorphism
 - (ii) Transform plate boundary and subduction plate boundary
 - (iii) Transverse dune and Longitudinal dune
 - (iv) Ripple marks and Swar marks
 - (v) Chemical sedimentary rock and Biochemical sedimentary rock.

3. (a) Briefly describe different types of igneous rocks based on mineralogy. Give examples. (8)
 (b) Write short notes on (answer any three): (4×3=12)
 - (i) Karst Landform
 - (ii) Continental drift
 - (iii) Shale
 - (iv) Barrier lake
 (c) Define clastic sediments. How is it converted to rock? (5)
 (d) Briefly discuss practical engineering aspects of folds. (5)
 (e) Briefly describe how wind and bathymetry affect sea-erosion. (5)

4. (a) Present a neat sketch of Bowen's reaction series. Discuss the formation of minerals at different stages of cooling of magma. (8)
 (b) What do you know about the earthquake risk of Bangladesh? (6)
 (c) What do you mean by metamorphic grade? Give examples of different grades of metamorphic rock. Describe any metamorphic rock of your choice. (9)

CE 203

Contd... Q. No. 4

- (d) Briefly describe the formation of the following with neat sketches (answer any three): (4×3=12)
- (i) V-shaped rock outcrop
 - (ii) Foliation in metamorphic rock
 - (iii) Caldera
 - (iv) Rift Valley.

SECTION-B

There are **FOUR** questions in this section. Answer any **THREE**.

5. (a) Explain the following terms with respect to an alluvial land formation: (i) meandering River, (ii) Oxbow lake, (iii) cutoff, (iv) natural levee. (12)
- (b) Write short notes on (i) Rectangular, (ii) Trellis, (iii) Radial types of drainage patterns with diagrams. (12)
- (c) Explain the following terms: (i) Drainage Density and (ii) Stream Frequency. With Bangladesh context, explain (with diagram) how these parameters can vary among the different regions. (11)
6. (a) Explain with diagram, the variation of the various morphological parameters of a river basin as it flows in the downstream direction. Explain these variations in the context of Bangladesh. (17)
- (b) With all necessary diagrams, explain the channel cross sectional changes during one flood season. Explain the movement of light and heavy particles during the season. Explain these changes with the variation in the river discharge as well. (18)
7. (a) What is river transportation? What are the factors affecting the transportation power of a river? How the knowledge of river transportation can help in determining (i) suitable size and (ii) adequate volume of blocks, in flood protection embankment design? (20)
- (c) What is longitudinal bed profile of a stream? What information does it give? Derive the equation of longitudinal bed profile of a stream. (15)
8. (a) What is lithification? Explain the process of lithification of sedimentary rock. (18)
- (b) Write down the percentage composition of various minerals found in granite. What is its texture? Explain how this type of texture is formed. (17)
-

SECTION – AThere are **FIVE** questions in this section. Answer any **FOUR**.

1. For the beam loaded as shown in Fig. 1, determine the maximum shearing stress that would develop. First draw shear force diagram for the beam. Specify in which segment (AB, BC or CD) the maximum shear stress will occur. (26 ¼)

2. Find the reactions for the frame ABCDE of Fig. 2. Hence draw shear force, axial force and bending moment diagrams for the structure. (26 ¼)

3. Draw axial force, shear force and bending moment diagrams for the beam shown in Fig. 3. (26 ¼)

4. A 6 meter span simple beam supports a point load of 12 kN at midspan. The beam is made of 50 mm thick wooden planks screwed together as shown in Fig. 4. Find the maximum shearing stress in the section and pitch of the screws for the top and bottom planks. Given that each screw can resist 950 N force. (26 ¼)

5. (a) Derive expressions for longitudinal and transverse (Hoop) stresses for a cylindrical pressure container of uniform shell thickness 't'. It is subjected to an internal pressure of 'p₀' and has an inside diameter 'D'. Use neat sketch in deriving these equations. (10)
(b) A cylindrical pressure vessel is made of steel plating having 20 mm thickness. The outside diameter is 490 mm and the vessel is 3 meter long. What internal pressure may be applied if the hoop stress and longitudinal stress are limited to 75 MPa and 160 MPa respectively? (16 ¼)

SECTION – B

There are **FIVE** questions in this section. Answer any **FOUR**.

6. A 30-in-long steel-alloy rod is enclosed within an aluminum tube; as shown in Fig. 5(a) and (b). The two materials are bonded together. If the stress-strain diagrams for the two materials can be idealized as shown in Fig. 5(d), what end deflection will occur for $P_1 = 75$ kip and for $P_2 = 115$ kip? The cross-sectional areas of steel and of aluminum are the same and equal to 0.5 in^2 . (26 ¼)

 7. A bracket of negligible weight shown in Fig. 6 is loaded with a vertical force P of 3 kip. Determine the deflection of point B caused by the applied vertical force. Also determine the vertical stiffness of the bracket at B. Given that cross-sectional area of members AB is 0.15 in^2 and that of BC is 0.265 in^2 and modulus of elasticity of the material is 10.3×10^3 ksi. (26 ¼)

 8. Two gears are attached to two 60-mm diameter steel shafts, as shown in Fig. 7. The gear at B has a 200-mm pitch diameter; the gear at C, a 400-mm pitch diameter. Through what angle will end "A" turn if at A a torque of 600 N-m is applied and end "D" of the second shaft is prevented from rotating? $G = 84$ GPa. (26 ¼)

 9. The overhanging beam in Fig. 8 is made of cast iron, for which the allowable stresses in tension and compression are 40 MPa and 100 MPa respectively. If the properties of the cross section are as shown, determine the maximum uniformly distributed load that can be supported. (26 ¼)

 10. A T beam shown in Fig. 9 is made of a material the behavior of which may be idealized as having a tensile proportional limit of 20 MPa and a compressive proportional limit of 40 MPa. With a factor of safety of 1.5 on the initiation of yielding, find the magnitude of the largest force "F" that may be applied to this beam in a downward direction as well as in an upward direction. Base answers only on the consideration of the maximum bending stresses caused by "F". (26 ¼)
-

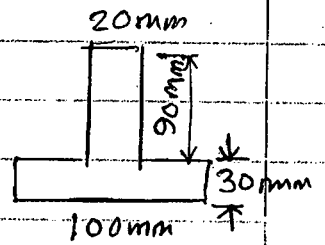
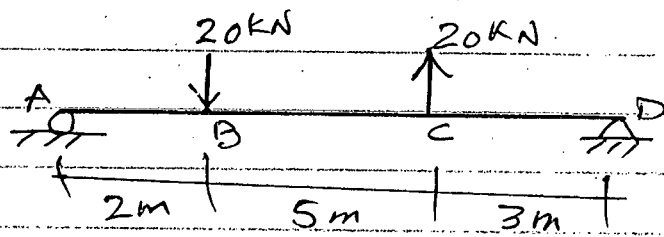

Fig. 1.

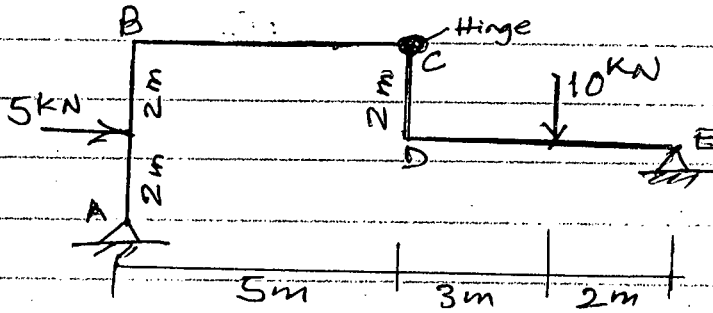

Fig. 2

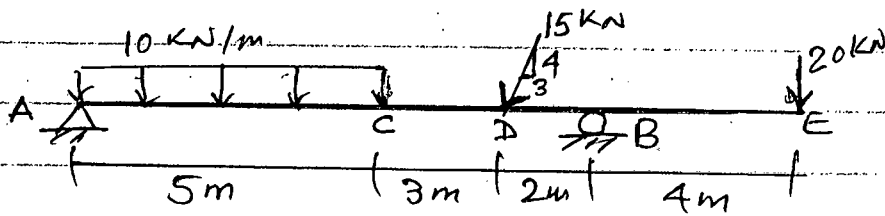

Fig. 3.

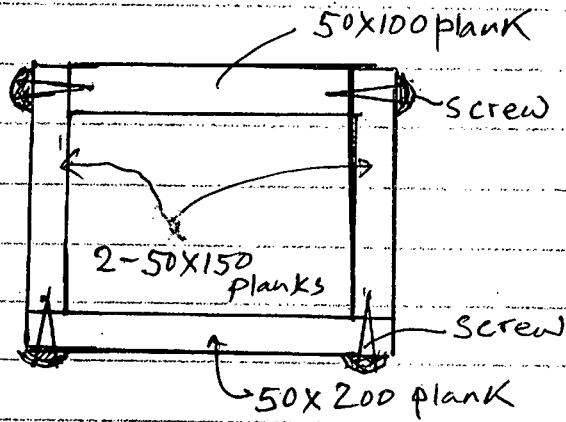

Fig. 4

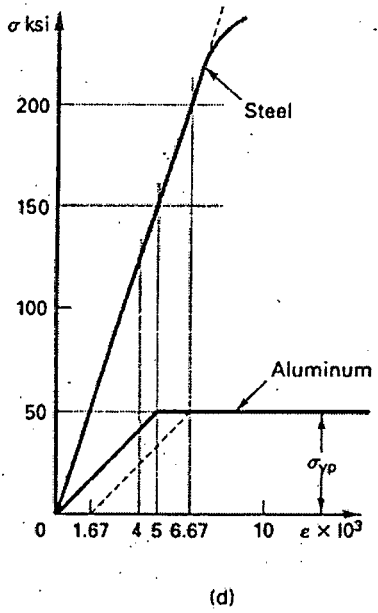
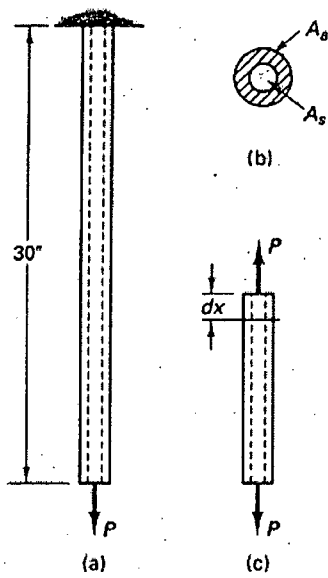

Figure 5

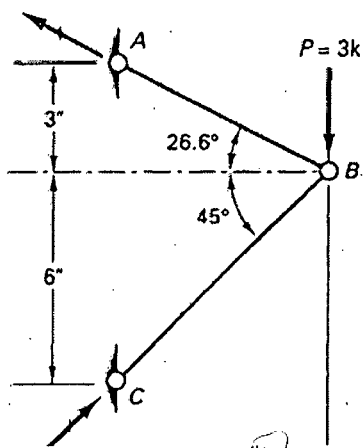

Figure 6

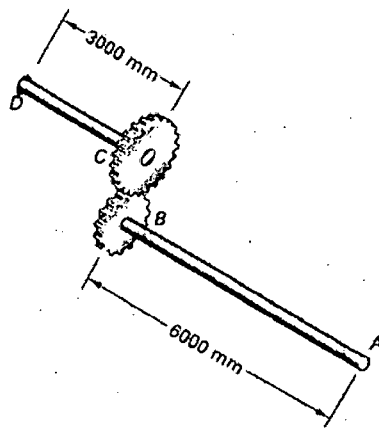

Figure 7

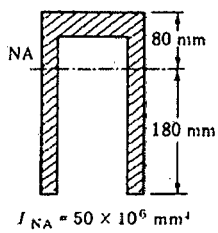
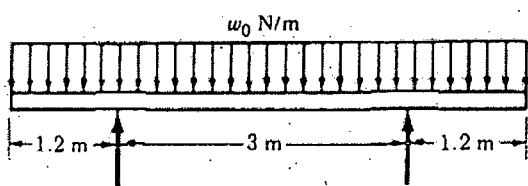

Figure 8

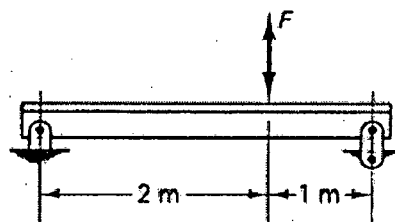
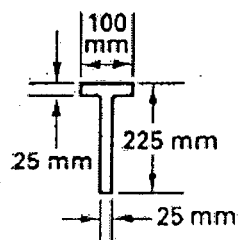

Figure 9

SECTION – A

There are **FOUR** questions in this section. Answer any **THREE**.

1. Crown creative makes high quality Personal Digital Assistant, Sales and production data relating to the most recent year are given below: (23 $\frac{1}{3}$)

Sales (in unit)	2,800
Selling price per unit (Tk.)	265
Contribution margin ratio	60%
Annual fixed costs (Tk.)	111,300

Management is anxious to improve the Company's profit performance and has asked for several items of information.

Requirements:

- (i) Compute break-even point in units and sales in Taka.
 - (ii) Assume that sales increases by Tk. 60,000 next year. If cost behavior patterns remain unchanged, by how much will company's net income increase?
 - (ii) Refer to the original data. Assume that next year management wants to earn a Tk. 182,850 profit. How many units will have to be sold to meet this target profit?
 - (iv) Refer to the original data. The sales manager is convinced that a 15% reduction in the selling price combined with a Tk. 56,100 increase in advertising cost could cause annual sales in units to increase by 40%, would you recommend that the company should do as the sales manager suggests?
 - (v) Refer to the original data. Compute margin of safety both in taka and percentage form.
 - (vi) Compute degree of operating leverage (DOL) at the present level of sales. Assume that the company likes to increase its net profit by 90% next year. By what percentage would you expect sales to increase? Use DOL to answer. Verify your answer by preparing income statement.
2. (a) In what situation, absorption costing will result higher net income than variable costing? Why? (3 $\frac{1}{3}$)
- (b) For the income year ended on December 31, 2014; you have been given the information below: (20)
- | | |
|------------------------|-------|
| Selling price per unit | Tk 50 |
|------------------------|-------|

HUM 353/CE

Contd... Q. No. 2 (b)

Variable cost per unit:

Direct materials	8
Direct labour	7
Variable manufacturing overhead	5
Variable selling and administrative overhead	2

Fixed costs:

Fixed manufacturing overhead	100,000
Fixed selling and administrative overhead	80,000

During the year, a total of 10,000 units produced but only 8500 units are sold.

Requirements:

- (i) Determine the unit product cost under absorption costing and variable costing methods.
 - (ii) Prepare income statements under both of the methods.
3. (a) Define the terms “manufacturing cost” and “Non-manufacturing cost” with examples. (3 1/3)
- (b) Classify costs according to cost behavior with examples. (5)
- (c) The following costs and inventory data are taken from the accounting records of Meriwell Company for the year ended on December 31st, 2015: (15)

Direct labour cost	Tk. 70,000
Purchase of raw materials	118,500
Indirect labour	30,000
Maintenance, factory equipment	6,000
Advertising expenses	90,000
Insurance, factory	800
Sales commission	35,000
Administrative manger’s salary	55,000
Supervisor’s Salary	12,000
Rent, factory	30,000
Rent, office	25,000
Rent, showroom	13,000
Utilities, factory	15,000
Supplies, office	3,000
Power and electricity	2,500
Depreciation, factory equipment	30,000
Director’s fees	15,000

HUM 353/CE

Contd... Q. No. 3 (c)

<u>Inventories</u>	<u>January 1</u>	<u>December 31</u>
Raw materials	Tk. 7,000	Tk. 15,000
Work-in-process	10,000	5000
Finished goods	20,000	35,000

Requirements:

- (i) Prepare a statement of cost of goods sold in good form.
- (ii) Prepare an income statement if sales amount is Tk. 700,000.

4. (a) The Lakeshore Hotel's guest day of occupancy and custodial supplies expenses over the last six month were:

(13 1/3)

<u>Month</u>	<u>Guest-day occupancy</u>	<u>Custodial supplies expenses</u>
March	4000	Tk. 75,000
April	6500	82,500
May	8000	105,000
Jun	10,500	120,000
July	12,000	135,000
August	9000	107,500

Guest-day is a measure of the overall activity at the Hotel.

Requirement:

- (i) Using the high-low method, calculate the variable cost per guest day occupancy and fixed cost for the period.
- (ii) Estimate a cost formula for custodial supplies expense in the form of $y = mx + c$.
- (iii) Using the cost formula, what would you expect to be incurred at an occupancy level of 11,000 guest day?

- (b) The Alex house is a large retailer of winter sports equipment. An income statement for the company's Ski Department for a recent quarter is given below:

(10)

Sales	Tk. 150,000	
Less: Cost of goods sold	90,000	
Gross profit	60,000	
Less: <u>Operating expenses</u>		
Selling cost	Tk. 30,000	
Administrative cost	10,000	40,000
Net profit	20,000	20,000

HUM 353/CE

Contd... Q. No. 4 (b)

Ski's sell, on the average, for Tk. 750 per pair, variable selling cost are Tk.50 per pair ski's sold. The reaming selling costs are fixed. The administrative costs are 20%, variable and 80% fixed. The company does not manufacture its own ski's, it purchases them from a supplier for Tk. 450 per pair.

Requirements:

Prepare an income statement for the quarter using the contribution approach.

SECTION-B

There are **FOUR** questions in this section. Answer any **THREE** questions.

5. (a) Define accounting. Discuss the accounting process. (5 1/3)
(b) Who are the users of accounting information? Explain briefly. (5)
(c) On October 1, Sabikun Nahar established Nahar's Travel Agency. The following events occurred during the month: (13)
1. Invested cash Tk. 1,000,000 to start the agency.
 2. Purchased equipment for Tk. 600,00 cash.
 3. Paid Tk. 20,000 cash for October office rent.
 4. Incurred Tk. 10,000 of advertising costs in the Daily Rising Sun, on account.
 5. Paid Tk. 5,000 cash for office supplies.
 6. Purchased a private car for personal use from personal money worth Tk. 300,000.
 7. Performed services worth Tk. 500,000; Tk.300,000 cash is received from customers, and the balance of Tk. 200,000 is billed to customers on account.
 8. Withdrew Tk. 15,000 cash for personal use.
 9. Paid the Daily Rising Sun Tk. 8,000 of the amount due in transaction (4).
 10. Paid employees' salaries Tk. 30,000.
 11. Borrowed Tk. 400,000 from the bank on a note payable.
 12. Received Tk.150,000 in cash from the customers who have previously been billed in transaction (7).
 13. Paid Tk. 2,000 for utilities.
- Required:
Prepare a tabular analysis of the above transaction.
6. (a) "If a trial balances, it guarantees that there are no errors in the recording process." Do you agree? Justify. (5 1/3)
(b) Sabikun Nahar is a licensed dentist. During the first month of the operation of her business, the following transactions occurred: (18)
- May 1 Invested Tk. 500,000 cash in her business.
 - " 2 Paid office rent for the month Tk. 20,000.
 - " 5 Purchased dental supplies on account for Tk. 50,000.
 - " 10 Performed dental services and billed the customers Tk. 40,000.
 - " 20 Collected cash from the customers Tk. 25,000.
 - " 26 Paid Tk. 30,000 to the supplier of dental supplies purchased on May 5.
 - " 30 Paid salaries Tk. 15,000.

HUM 353/CE

Contd... Q. No. 6 (b)

Required:

- (i) Journalize the transactions.
- (ii) Post to the ledger accounts.
- (iii) Prepare a trial balance as on 31 May.

7. (a) What is meant by adjusting the accounts? Describe various types of adjusting entries with an example from each of them. (6 1/3)

(b) The Kerniganj Rentals opened for business on January 1, 2016. its trial balance before adjustment on December 31 is as follows: (17)

Keraniganj Rentals			
Trial Balance			
As on December 31, 2016			
SI NO.	Accounts Title	Debit (Tk.)	Credit (Tk.)
1.	Cash	20,000	
2.	Accounts Receivable	50,000	
3.	Supplies	10,000	
4.	Prepaid Insurance	30,000	
5.	Land	500,000	
6.	Buildings	400,000	
7.	Equipment	600,000	
8.	Accounts Payable		80,000
9.	Unearned Rent Revenue		120,000
10.	Mortgage Payable		300,000
11.	Owner's Capital		800,000
12.	Owner's Drawings	20,000	
13.	Rent Revenue		400,000
14.	Advertising Expense	20,000	
15.	Salaries & Wages Expense	40,000	
16.	Utilities Expense	10,000	
	Total	<u>1,700,000</u>	<u>1,700,000</u>

Other data:

- 1. Prepaid insurance is a one-year policy starting June 1, 2016.
- 2. A count of supplies shows that Tk. 7,000 of supplies has been used during the year.
- 3. Annual depreciation is Tk. 20,000 on the buildings and Tk. 30,000 on the equipment.
- 4. The mortgage interest rate is 12%. (The mortgage was taken out on July 1.)
- 5. Two-thirds of the unearned rent revenue has been earned.
- 6. Salaries of Tk. 20,000 are accrued and unpaid at December 31.

Required:

- (i) Prepare the adjusting entries that are necessary.
- (ii) Prepare an adjusted trial balance as on 31 December 2016.

HUM 353/CE

4. (a) What is a financial statement? Discuss in brief the components of a complete set of financial statements.

(7 1/3)

(b) The Taranagar Enterprise opened for business on July 1, 2015. Its adjusted trial balance on June 30, 2016 is as follows:

(16)

Taranagar Enterprise			
Adjusted Trial Balance			
As on June 30, 2016			
SI NO.	Accounts Title	Debit (Tk.)	Credit (Tk.)
1.	Cash	50,000	
2.	Accounts Receivable	100,000	
3.	Inventory	80,000	
4.	Supplies	30,000	
5.	Prepaid Insurance	30,000	
6.	Land	500,000	
7.	Buildings	800,000	
8.	Accumulated Depreciation – Buildings		40,000
9.	Equipment	600,000	
10.	Accumulated Depreciation – Equipment		30,000
11.	Accounts Payable		70,000
12.	Notes Payable		80,000
13.	Unearned Service Revenue		90,000
14.	Interest Payable		10,000
15.	Mortgage Payable		500,000
16.	Bank Loan (long-term)		300,000
17.	Owner’s Capital		1,000,000
18.	Owner’s Drawings	50,000	
19.	Sales Revenue		850,000
20.	Investment Income		30,000
21.	Sales Returns	20,000	
22.	Sales Discounts	10,000	
23.	Cost of Goods Sold	500,000	
24.	Advertising Expense	30,000	
25.	Interest Expense	10,000	
26.	Supplies Expense	19,000	
27.	Insurance Expense	6,000	
28.	Salaries & Wages Expense	80,000	
29.	Depreciation Expense	70,000	
30.	Utilities Expense	5,000	
31.	Miscellaneous Expense	10,000	
	Total	<u>3,000,000</u>	<u>3,000,000</u>

Required:

- (i) Prepare a multiple-step income statement for the year ended 30 June 2016.
- (ii) Prepare a classified balance sheet as at 30 June 2016.

SECTION – AThere are **FOUR** questions in this section. Answer any **THREE**.

1. (a) Prove that the vectors $\underline{A} = 3\mathbf{i} + \mathbf{j} - 2\mathbf{k}$, $\underline{B} = -\mathbf{i} + 3\mathbf{j} + 4\mathbf{k}$, $\underline{C} = 4\mathbf{i} - 2\mathbf{j} - 6\mathbf{k}$ can form the sides of a triangle. Find the lengths of the medians of the triangle. (15)
- (b) Consider the vectors $\underline{a} = \mathbf{i} - 3\mathbf{j} + 2\mathbf{k}$, $\underline{b} = 2\mathbf{i} - 4\mathbf{j} - \mathbf{k}$, $\underline{c} = 3\mathbf{i} + 2\mathbf{j} - \mathbf{k}$. (10)
- (i) Find the vector component of \underline{a} in the direction of \underline{b} and perpendicular to \underline{b} .
- (ii) Determine whether the vectors \underline{a} , \underline{b} , \underline{c} , are coplanar or not. (10)
2. (a) If the vectors $\underline{u} = 2\mathbf{i} - \mathbf{j} + \mathbf{k}$, $\underline{v} = \mathbf{i} + 3\mathbf{j} - 2\mathbf{k}$, $\underline{w} = -2\mathbf{i} + \mathbf{j} - 3\mathbf{k}$ are linearly independent then express the vector $\underline{x} = 3\mathbf{i} + 2\mathbf{j} + 5\mathbf{k}$ as a linear combination of \underline{u} , \underline{v} , \underline{w} . (14)
- (b) In what direction from the point (2, 1, -1) is the directional derivative of $\phi = x^2yz^3$ a maximum? What is the magnitude of this maximum? (10)
- (c) Show that $\underline{A} = (6xy + z^3)\mathbf{i} + (3x^2 - z)\mathbf{j} + (3xz^2 - y)\mathbf{k}$ is irrotational. Find ϕ such that $\underline{A} = \nabla\phi$. (11)
3. (a) Evaluate $\int_C \underline{F} \times d\underline{r}$ for the vector function $\underline{F} = -y\mathbf{i} + x\mathbf{j}$ along the boundary (anti clockwise) of the region bounded by $y = x$ and $y^2 = 4x$. Also find the area of the enclosed region using Green's theorem for plane. (17)
- (b) Evaluate $\iint_S \underline{A} \cdot \underline{n} dS$, where $\underline{A} = z\mathbf{i} + x\mathbf{j} - 3y^2z\mathbf{k}$ and S is the surface of the cylinder $x^2 + y^2 = 16$ included in the first octant between $z = 0$ and $z = 5$. (18)
4. (a) Find the work done in moving a particle once around a circle C in the xy plane, if the circle has center at the origin and radius 3 and if the force field is given by $\underline{F} = (2x - y + z)\mathbf{i} + (x + y - z^2)\mathbf{j} + (3x - 2y + 4z)\mathbf{k}$. (17)
- (b) Use the Divergence Theorem to find the outward flux of the vector field $\underline{F}(x, y, z) = x^3\mathbf{i} + y^3\mathbf{j} + z^3\mathbf{k}$ across the surface of the region that is enclosed by the hemisphere $z = \sqrt{a^2 - x^2 - y^2}$ and the plane $z = 0$. (18)

MATH 237/CE**SECTION - B**

There are **FOUR** questions in this section. Answer any **THREE**.

5. (a) State Stoke's theorem and verify this theorem for the vector function $\vec{F} = (x + y)\mathbf{i} + (2x - z)\mathbf{j} + (y + z)\mathbf{k}$ taken over the triangle ABC cuts from the plane $3x + 2y + z = 6$ by the co-ordinate plane. (20)

(b) By using Gauss divergence theorem evaluate $\iiint_S \vec{F} \cdot \vec{n} dS$, where

$\vec{F} = x\mathbf{i} - y\mathbf{j} + (z^2 - 1)\mathbf{k}$ and S is the cylinder formed by the surfaces $z = 0, z = 1, x^2 + y^2 = 4$. (15)

6. (a) Prove that $L\{\sin(\sqrt{t})\} = \frac{\sqrt{\pi}}{2s^{3/2}} e^{-\frac{1}{4s}}$ (8)

(b) If $L\{F(t)\} = f(s)$, then show that $L\left\{\int_0^t F(u) du\right\} = \frac{f(s)}{s}$ and hence evaluate

$$\int_0^\infty \int_0^t \frac{\sin u}{u} du dt \quad (12)$$

(c) Show that $L\{\cos t Si(t) - \sin t Ci(t)\} = \frac{\ln s}{s^2 + 1}$. (15)

7. Evaluate the following:

(a) $L^{-1}\left\{\frac{s}{\sqrt[3]{s^4 - 8s^3 + 24s^2 - 32s + 16}}\right\}$ (10)

(b) $L^{-1}\left\{\frac{1}{(s-2)(s+2)^2}\right\}$ by using Heaviside's expansion formula (12)

(c) $L^{-1}\left\{\frac{s^{\frac{3}{2}}}{(s-1)}\right\}$ by using convolution theorem. (13)

8. (a) Solve $Y'''(t) - 3Y''(t) + 3Y'(t) - Y(t) = t^2 e^t$ given that

$$Y(0) = 1, Y'(0) = 0 \text{ and } Y''(0) = -2$$

by using Laplace transform. (18)

(b) Use Laplace transforms to solve the following differential equation (17)

$$tY''(t) + (1 - 2t)Y'(t) - 2Y(t) = 0, Y(0) = 1, Y'(0) = 2$$