

M.SC. ENGG. THESIS

OVERCOMING THROUGHPUT DEGRADATION IN MULTI-RADIO COGNITIVE RADIO NETWORKS

by

TANVIR AHMED KHAN (1014052013)

Submitted to

Department of Computer Science & Engineering

(In partial fulfilment of the requirements for the degree of
Master of Science in Computer Science & Engineering)

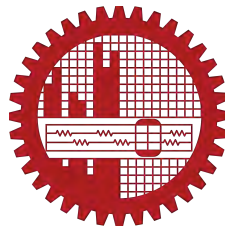

Department of Computer Science & Engineering

Bangladesh University of Engineering & Technology (BUET)

Dhaka 1000

July 22, 2017

Dedicated to my loving parents

AUTHOR'S CONTACT

Tanvir Ahmed Khan

Lecturer,

Department of Computer Science & Engineering,
Bangladesh University of Engineering & Technology (BUET), Dhaka.

Email: takhan@cse.buet.ac.bd, takhandipu@gmail.com

The thesis titled “Overcoming Throughput Degradation in Multi-Radio Cognitive Radio Networks”, submitted by Tanvir Ahmed Khan, Roll No. **1014052013**, Session October 2014, to the Department of Computer Science & Engineering, Bangladesh University of Engineering & Technology, has been accepted as satisfactory in partial fulfillment of the requirements for the degree of Master of Science in Computer Science & Engineering and approved as to its style and contents. Examination held on July 22, 2017.

Board of Examiners

1. _____

Dr. A. B. M. Alim Al Islam
Associate Professor
Department of Computer Science & Engineering
Bangladesh University of Engineering & Technology, Dhaka.

Chairman
(Supervisor)

2. _____

Dr. M. Sohel Rahman
Head and Professor
Department of Computer Science & Engineering
Bangladesh University of Engineering & Technology, Dhaka.

Member
(Ex-Officio)

3. _____

Dr. A.K.M. Ashikur Rahman
Professor
Department of Computer Science & Engineering
Bangladesh University of Engineering & Technology, Dhaka.

Member

4. _____

Dr. Mahmuda Naznin
Professor
Department of Computer Science & Engineering
Bangladesh University of Engineering & Technology, Dhaka.

Member

5. _____

Dr. Md. Abdur Razzaque
Professor
Department of Computer Science & Engineering
University of Dhaka, Dhaka.

Member
(External)

Candidate's Declaration

This is hereby declared that the work titled “Overcoming Throughput Degradation in Multi-Radio Cognitive Radio Networks”, is the outcome of research carried out by me under the supervision of Dr. A. B. M. Alim Al Islam, in the Department of Computer Science & Engineering, Bangladesh University of Engineering & Technology, Dhaka 1000. It is also declared that this thesis or any part of it has not been submitted elsewhere for the award of any degree or diploma.

Tanvir Ahmed Khan
Candidate

Acknowledgment

Foremost, I express my heart-felt gratitude to my supervisor, Dr. A. B. M. Alim Al Islam, for his constant supervision of this work. He helped me a lot in every aspect of this work and guided me with proper directions whenever I sought one. His patient hearing of my ideas, critical analysis of my observations and detecting flaws (and amending thereby) in my thinking and writing have made this thesis a success.

I would also want to thank the members of my thesis examination committee: Dr. M. Sohel Rahman, Dr. A.K.M. Ashikur Rahman, Dr. Mahmuda Naznin, and specially the external member Dr. Md. Abdur Razzaque, for their encouragements, insightful comments, and valuable suggestions.

I am also thankful to Chowdhury Sayeed Hyder (Software Engineer, DS SQL Engineering, Microsoft, Redmond, WA, USA.). I sought help from him a number of occasions regarding simulation set-up and performance evaluation of this thesis. In addition, I am grateful to Md. Jahidul Islam (PhD Candidate, University of Minnesota -Twin Cities), Novia Nurain (Assistant Professor, CSE-UIU), Abdus Salam Azad (Lecturer, CSE-BUET), and Md. Ishaq-E-Rabban (Lecturer, CSE-BUET) for their help and valuable suggestions regarding the writing and presentation of this thesis.

Last but not the least, I remain ever grateful to my beloved parents, who always exists as sources of inspiration behind every success of mine.

Abstract

In recent years, Cognitive Radio Networks (CRNs) have been widely investigated to solve the well-known spectrum scarcity problem through enhancing spectrum utilization. Another technique of enhancing spectrum utilization, which has already been well accepted, is to utilize multiple radios on a single node. Simultaneous usage of both these techniques is therefore expected to enhance the spectrum utilization further in road to improving overall network performance. However, little research efforts have been spent on investigating performance of the simultaneous usage through incorporating multiple radios in each node of a CRN. Existing studies in this regard propose several protocols for Multi-Radio Cognitive Radio Networks (MRCRNs). However, none of them focuses on increasing throughput in the network to the best of our knowledge. Nonetheless, increased network throughput should be a direct consequence of enhanced spectrum utilization through exploiting multiple radios in CRNs, even though an existing study [1] reports getting decreased network throughput while introducing multiple radios in each node of a CRN. Thus, a specialized treatment to the multiple radios in each node of a CRN is needed for increasing network throughput. Accordingly, in this study, we propose a feedback-based multi-radio exploitation approach for MRCRNs, where information obtained from lower layers (Physical layer and Data Link layer) is incorporated in the process of decision making in an upper layer (Application layer) to enhance network throughput. We implement our proposed approach in ns-3 to measure different performance metrics including network throughput, average end-to-end delay, and average packet drop ratio. We compare the performance against that of existing multi-radio exploitation approaches for CRNs. Our simulation results reveal that our proposed feedback-based approach always achieves substantially increased network throughput compared to existing approaches, in parallel to achieving improved delay and packet drop-ratio in most of the cases.

Contents

| | |
|---|-----------|
| <i>Board of Examiners</i> | ii |
| <i>Candidate's Declaration</i> | iii |
| <i>Acknowledgment</i> | iv |
| <i>Abstract</i> | v |
| 1 Introduction | 1 |
| 1.1 Research Challenges | 2 |
| 1.2 Research Methodology | 3 |
| 1.3 Summary of Contributions | 5 |
| 2 Background and Related Work | 6 |
| 2.1 Cognitive Radio | 6 |
| 2.1.1 Working Method of A Cognitive Radio | 7 |
| 2.2 Cognitive Radio Networks (CRNs) | 8 |
| 2.3 Applications of CRNs | 10 |
| 2.4 Multi-Radio Networks | 11 |
| 2.5 Multi-Radio Cognitive Radio Networks (MRCRNs) | 11 |
| 2.6 Existing Studies on MRCRNs | 11 |
| 3 System Model and Problem Definition | 14 |
| 3.1 System Model | 14 |
| 3.2 Problem Definition | 15 |

| | | |
|----------|---|-----------|
| 4 | Feedback-based Multi-radio Exploitation Approach | 17 |
| 4.1 | Overview of The Proposed Approach | 17 |
| 4.2 | Radio Selection Based on Packet Transmission Ratio | 18 |
| 4.3 | Channel Selection Based on Channel Utilization Ratio | 19 |
| 4.4 | Sequential Radio and Channel Selection | 22 |
| 4.5 | Weighted Lottery Mechanism | 22 |
| 4.6 | Variants of Our Proposed Approach | 23 |
| 5 | Experimental Evaluation | 24 |
| 5.1 | Simulator Modifications | 24 |
| 5.2 | Simulation Settings | 25 |
| 5.3 | Results and Analysis | 26 |
| 5.4 | Simulation Findings | 32 |
| 6 | Conclusion and Future Work | 35 |
| | Appendix A Simulation Results for Different Network Topologies | 36 |

List of Figures

| | | |
|-----|--|----|
| 1.1 | Licensed frequency spectrums are mostly under-utilized | 1 |
| 1.2 | Dynamic spectrum access through cognitive radio networks | 2 |
| 1.3 | Advantages of multi-radio networks | 3 |
| 1.4 | Operational block diagram of our proposed feedback-based multi-radio exploitation approach | 4 |
| 2.1 | Cognitive radio transceiver | 7 |
| 2.2 | Wideband RF/analog front-end architecture of a cognitive radio | 8 |
| 2.3 | Cognitive radio networks architecture | 9 |
| 2.4 | Applications of cognitive radio networks | 10 |
| 2.5 | Secondary users (SUs) equipped with multiple radios experience reduced switching delay | 12 |
| 3.1 | System model of a MRCCRN | 15 |
| 4.1 | High-level overview of the proposed approach | 18 |
| 5.1 | Average network throughput and end-to-end delay with varying simulation end time . | 26 |
| 5.2 | Average network throughput with varying number of radios for various application data rates | 28 |
| 5.3 | Average end-to-end delay with varying number of radios for various application data rates | 29 |
| 5.4 | Average packet drop ratio with varying number of radios for various application data rates | 30 |
| 5.5 | Application layer packet delivery ratio with varying number of radios for various application data rates | 31 |

| | | |
|------|--|----|
| A.1 | Average network throughput with varying number of radios for various application data rates on a network topology with 12 secondary users | 37 |
| A.2 | Average end-to-end delay with varying number of radios for various application data rates on a network topology with 12 secondary users | 38 |
| A.3 | Average packet drop ratio with varying number of radios for various application data rates on a network topology with 12 secondary users | 39 |
| A.4 | Application layer packet delivery ratio with varying number of radios for various application data rates on a network topology with 12 secondary users | 40 |
| A.5 | Average network throughput with varying number of radios for various application data rates on a network topology with 16 secondary users | 41 |
| A.6 | Average end-to-end delay with varying number of radios for various application data rates on a network topology with 16 secondary users | 42 |
| A.7 | Average packet drop ratio with varying number of radios for various application data rates on a network topology with 16 secondary users | 43 |
| A.8 | Application layer packet delivery ratio with varying number of radios for various application data rates on a network topology with 16 secondary users | 44 |
| A.9 | Average network throughput with varying number of radios for various application data rates on a network topology with 20 secondary users | 45 |
| A.10 | Average end-to-end delay with varying number of radios for various application data rates on a network topology with 20 secondary users | 46 |
| A.11 | Average packet drop ratio with varying number of radios for various application data rates on a network topology with 20 secondary users | 47 |
| A.12 | Application layer packet delivery ratio with varying number of radios for various application data rates on a network topology with 20 secondary users | 48 |
| A.13 | Average network throughput with varying number of radios for various application data rates on a network topology with 28 secondary users | 49 |
| A.14 | Average end-to-end delay with varying number of radios for various application data rates on a network topology with 28 secondary users | 50 |
| A.15 | Average packet drop ratio with varying number of radios for various application data rates on a network topology with 28 secondary users | 51 |

| | |
|---|----|
| A.16 Application layer packet delivery ratio with varying number of radios for various application data rates on a network topology with 28 secondary users | 52 |
| A.17 Average network throughput with varying number of radios for various application data rates on a network topology with 32 secondary users | 53 |
| A.18 Average end-to-end delay with varying number of radios for various application data rates on a network topology with 32 secondary users | 54 |
| A.19 Average packet drop ratio with varying number of radios for various application data rates on a network topology with 32 secondary users | 55 |
| A.20 Application layer packet delivery ratio with varying number of radios for various application data rates on a network topology with 32 secondary users | 56 |
| A.21 Average network throughput with varying number of radios for various application data rates on a network topology with 36 secondary users | 57 |
| A.22 Average end-to-end delay with varying number of radios for various application data rates on a network topology with 36 secondary users | 58 |
| A.23 Average packet drop ratio with varying number of radios for various application data rates on a network topology with 36 secondary users | 59 |
| A.24 Application layer packet delivery ratio with varying number of radios for various application data rates on a network topology with 36 secondary users | 60 |
| A.25 Average network throughput with varying number of radios for various application data rates on a network topology with 40 secondary users | 61 |
| A.26 Average end-to-end delay with varying number of radios for various application data rates on a network topology with 40 secondary users | 62 |
| A.27 Average packet drop ratio with varying number of radios for various application data rates on a network topology with 40 secondary users | 63 |
| A.28 Application layer packet delivery ratio with varying number of radios for various application data rates on a network topology with 40 secondary users | 64 |

List of Tables

| | | |
|-----|---|----|
| 4.1 | Several variants of the proposed feedback-based approach | 23 |
| 5.1 | Performance improvement achieved using our proposed radio feedback-based approach compared to the approaches proposed by Khan et al., [1] and Zhong et al., [2] | 33 |
| 5.2 | Performance improvement achieved using our proposed channel feedback-based approach compared to the approaches proposed by Khan et al., [1] and Zhong et al., [2] . | 33 |
| 5.3 | Performance improvement achieved using our proposed radio channel feedback-based approach compared to the approaches proposed by Khan et al., [1] and Zhong et al., [2] | 34 |

List of Algorithms

| | | |
|---|--|----|
| 1 | <i>sendPacket</i> : SU agent sending a packet, p | 20 |
| 2 | <i>startSensing</i> : SU's radio sensing its channel | 20 |
| 3 | <i>startSwitching</i> : SU's radio changing its channel | 20 |
| 4 | <i>transmitPacket</i> : SU's radio transmitting a packet, p | 20 |
| 5 | <i>receiveAckPacket</i> : SU's radio receiving an Ack packet, p | 20 |
| 6 | <i>getSelectedRadio</i> : Selects an SU radio to send a packet | 21 |
| 7 | <i>getSelectedChannel</i> : Selects a new channel to switch for an SU radio over the <i>availableChannels</i> | 21 |

Chapter 1

Introduction

The famous spectrum scarcity problem [3] along with significant spectrum under-utilization [4] (Figure 1.1 [4]) in traditional spectrum management has led towards the notion of dynamic spectrum access [5] through cognitive radios. A *cognitive radio* monitors its operational electromagnetic environment to dynamically adjust its operating parameters [6]. Thus, a cognitive radio is capable of accessing temporal free spectrums. Cognitive Radio Networks (CRNs) exploit cognitive radios in their nodes for enabling access to temporal free spectrums. The typical architecture of CRNs comprises of two types of users as shown in Figure 1.2. The first type of users refers to *primary users* (PUs), who possess licenses to operate over different spectrum bands. The second type of users refers to *secondary users* (SUs), who are unlicensed and employ cognitive radios to opportunistically access instantaneous spectrum holes.

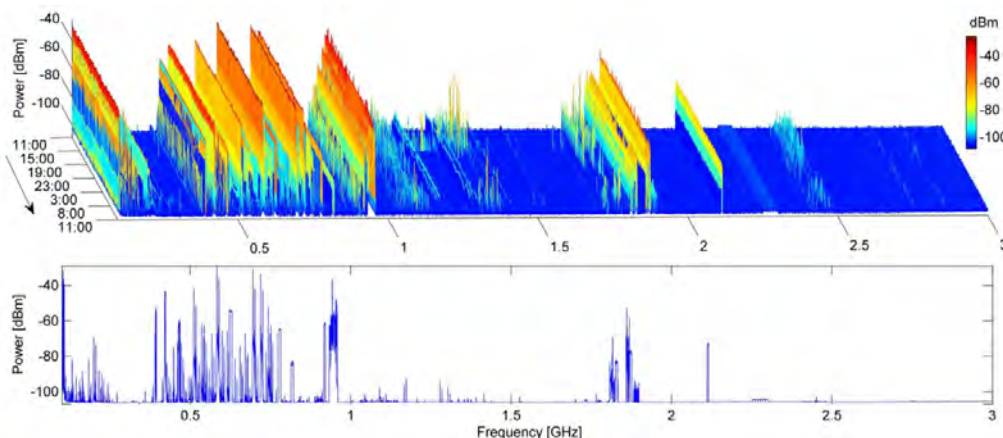

Figure 1.1: Licensed frequency spectrums are mostly under-utilized

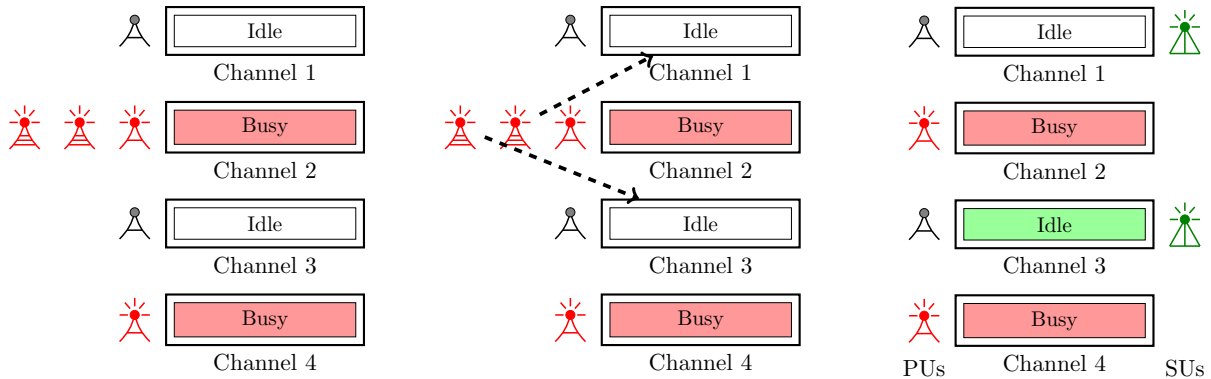

Figure 1.2: Dynamic spectrum access through cognitive radio networks

On the other hand, classical wireless networks frequently adopt the notion of deploying users with multiple radios [7, 8]. Such deployment of multiple radios improves capacity of the networks [9, 7], enhances loss resilience [10], and enables heterogeneous wireless access for smart devices [11] (Figure 1.3). As such deployment of multiple radios in wireless nodes is known to improve the performance of a user and deployment of cognitive radios also aims to improve the performance of secondary users through spectrum utilization, it is intuitive that simultaneous utilization of both these techniques, i.e., Multi-Radio Cognitive Radio Networks (MRCRNs), will result in significantly improved network performance. Therefore, the notion of exploiting multiple radios in CRNs to supplement the dynamic spectrum access has been proposed in the contemporary literature [12, 2, 1]. Existing studies in this regard present that such multi-radio deployment in CRNs improves delay up to a certain point, however, throughput always degrades with an increase in the number of radios per secondary user [1]. Therefore, examining how to improve network throughput while equipping secondary users with multiple radios still remains an open research problem in the literature.

1.1 Research Challenges

The main challenge of improving total network throughput in MRCRNs lies on the silent features of the architecture of CRNs. In CRNs, nodes generally have limited spectrum knowledge covering only its own neighborhood, as the knowledge is conventionally gathered in a distributed manner. Therefore, existing graph-based and MILP optimization-based solutions [13, 14] for improving throughput can

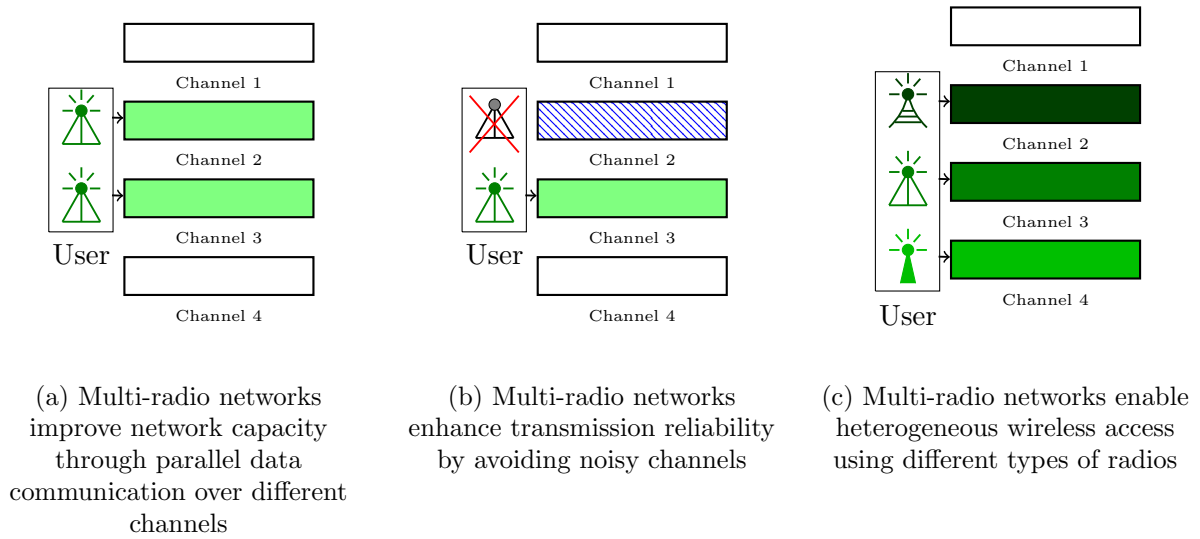

Figure 1.3: Advantages of multi-radio networks

not be directly incorporated due to their nature of performing centralized computations. Moreover, the relation between two different performance metrics namely throughput and delay may be opposing in nature [15] and improving one of them may result in degradation of the another. Consequently, a trade-off between these two metrics demands a special attention in MRCRNs in road to improving network throughput.

Most of the existing studies on MRCRNs fail to solve the research problem of improving network throughput, as they overlook the effect of utilizing multiple radios on different performance metrics. Several studies existing in this regard [16, 17, 2, 12] usually attempt to integrate different protocols for the multi-radio network architectures and to solve the channel assignment problem for multi-channel scenario. Besides, while assigning multiple channels among multiple radios, existing studies either randomly select the channels [1] or select the channels based only on their own rankings [2] without taking any specialized measure. Due to all these reasons, to the best of our knowledge, no existing research study provides a viable solution for enhancing throughput in MRCRNs.

1.2 Research Methodology

In this thesis, we propose a feedback-based multi-radio exploitation approach for cognitive radio networks. Our proposed approach tries to integrate a specialized mechanism of incorporating feedback obtained from radio transmission environment in the process of decision making in Data Link layer to

enhance network throughput. Here, to obtain radio environment feedback, we keep different packet counters for each radio as well as for each channel in each secondary user. Using values of all these counters, we rank both the radios and channels available to a secondary user. Subsequently, based on the ranking, we make packet queuing decisions and channel switching decisions from the Data Link layer while retaining a stochastic flavor.

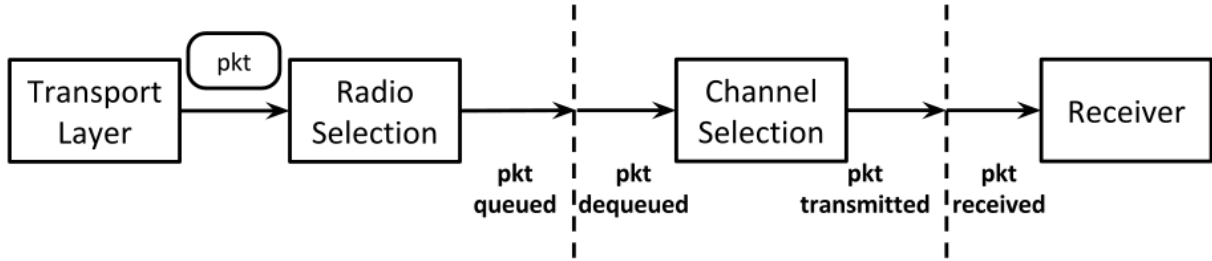

Figure 1.4: Operational block diagram of our proposed feedback-based multi-radio exploitation approach

Figure 1.4 depicts the operational steps of our proposed feedback-based multi-radio exploitation approach. When a transport layer packet is received on the data link layer, our proposed approach first selects the radio to take the responsibility of transmitting the packet. This radio selection process is performed based on two radio counters, the number of total packets queued on the radio and the number of total packets transmitted by the radio. After selecting the radio, our secondary user agent enqueues the packet on the corresponding selected radio queue. It is to be noted here that, the channel selection process is not performed at that time. The channel is selected only after the dequeuing of the packet. After the packet is dequeued from the selected radio's queue, the radio senses its currently assigned channel for primary user activity. If the radio senses that there is no primary user on that channel the packet is transmitted on that channel. However, if the primary user is active on that channel, the radio has to switch to another channel. Only then, the channel selection process is performed to find another channel to which the radio senses next for primary user activity. This channel selection process is conducted based on two channel counters, the number of total packets transmitted by the corresponding secondary user on the channel and the number of total packets successfully received by the receiver on the channel.

We implement our proposed feedback-based approach in `ns-3` to evaluate its performance in terms of throughput along with delay and drop ratio. Our simulation results demonstrate that the proposed

approach can achieve significant improvement in network throughput in addition to improving other performance metrics in most of the cases.

1.3 Summary of Contributions

Based on our study in this thesis, we make the following set of contributions:

- We propose a feedback-based multi-radio exploitation approach, along with several variants, to solve the throughput degradation problem in MRCRNs. In our proposed approach, performance information obtained from lower layers (Physical layer and Data link layer) is incorporated in the process of upper layer (Application layer) decision making on radio and channel selection.
- We evaluate the performance of our proposed approach through discrete-event simulation. We implement the proposed approach and its variants in `ns-3` to demonstrate efficacy of their radio selection and channel selection policies, and measure various performance metrics in response to an increase in the number of radios per SU.
- We compare performance of our proposed approach against that of existing approaches in the literature. Comparative results confirm significant improvement over existing approaches through using our proposed approach. Our proposed approach increases total network throughput by 51%, decreases packet drop ratio by 35%, and decreases end-to-end delay by 13% on an average against that of other existing approaches.

Chapter 2

Background and Related Work

Traditional analog model for spectrum management resulted into the inefficient utilization of most radio frequency spectrum [4]. While several mobile network spectrum bands are highly congested, other spectrum bands such as TV space and non-commercial radio bands are overly under-utilized. Moreover, these utilization varies depending on time and place resulting into spectrum hole [18]. Subsequently, the notion of cognitive radio was proposed to exploit these temporal and spatial spectrum holes.

2.1 Cognitive Radio

Cognitive radio is a special kind of radio with two unique attributes namely cognitive capability and reconfigurability [5, 19, 20]. Cognitive capability enables cognitive radio to sense its radio environment. The radio environment sensing process involves observing the power in various spectrum bands as well as identifying temporal and spatial spectrum holes [5]. On the other hand, reconfigurability helps cognitive radio to communicate over various spectrum bands to improve spectrum utilization based on its spectrum awareness [21].

Based on these two special characteristics, the primary objective of cognitive radio can be best understood from its widely adopted definition as follows [22]:

“A cognitive radio is a radio or system that senses its operational electromagnetic environment and can dynamically and autonomously adjust its radio operating parameters to modify system operation, such as maximize throughput, mitigate interference, facilitate

interoperability, access secondary markets.”

Given the fixed nature of traditional spectrum allocation, the primary challenge of cognitive radio is to exploit spectrum holes in the licensed band while not causing any interruption to the licensed users. Therefore, while using a temporally and/or spatially free spectrum, if the licensed user starts using the corresponding spectrum, the cognitive radio must have the capability to switch to another spectrum or change its other transmission parameters to avoid interruption with the licensed user. Next, we present how a cognitive radio achieves this goal.

2.1.1 Working Method of A Cognitive Radio

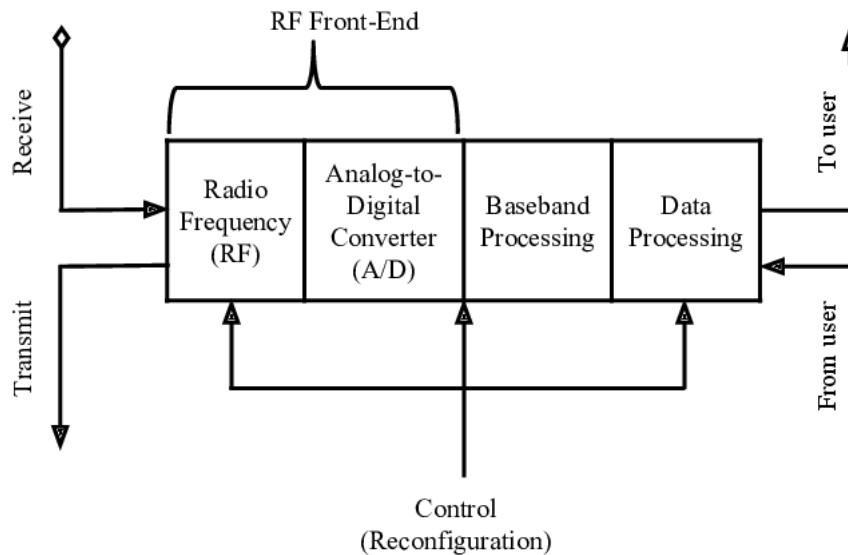

Figure 2.1: Cognitive radio transceiver

As shown in Figure 2.1 (redrawn from [21]), the cognitive radio transceiver is consisted of a radio front-end and a processing unit [5]. The most important fact that distinguishes cognitive radios from other traditional radios is cognitive radio’s ability to reconfigure itself via a control bus parameterizing both the radio front-end and processing units [21]. The radio front-end amplifies and mixes the received signal and then converts it from analog to digital signal. The processing unit doing the job of baseband and data processing is quite similar to conventional radio transceivers. Nonetheless, the unique design of cognitive radio’s front end also attributes to its novelty, and therefore, we will discuss the radio front-end up next.

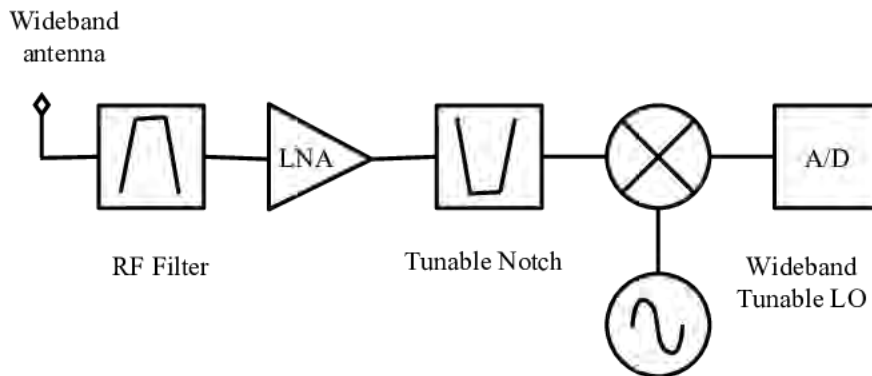

Figure 2.2: Wideband RF/analog front-end architecture of a cognitive radio

The radio front-end of a cognitive radio is illustrated in Figure 2.2 (redrawn from [23]). It has a wideband sensing capability mainly due to its components such as wideband antenna, power amplifier, and adaptive filter. This wideband sensing capability of the radio front end enables cognitive radio to tune to any part of a wide spectrum band. This capability also helps cognitive radio to measure any spectrum information of radio surroundings. To accomplish all this, a wideband radio front-end needs to have several components [5]: RF filter, low noise amplifier (LNA), tunable notch, wideband tunable local oscillator (LO), and analog to digital (A/D) converter. RF filter works as a bandpass filter selecting only the desired band RF signal. LNA minimizes the signal noise and amplifies the desired signals amplitude. Tunable notch filters the selected channel from the signal and rejects adjacent channels. Wideband tunable LO has mainly two components: voltage-controlled oscillator (VCO) and mixer. VCO usually can generate signals at any specific frequency and this locally generated RF signal is mixed with desired signal at mixer to convert it into a baseband signal. A/D converter samples and quantizes this signal with very high resolution.

A Cognitive Radio Network (CRN) exploits the capability of cognitive radios. Next, we present how the CRN architecture employs cognitive radios to increase spectrum utilization.

2.2 Cognitive Radio Networks (CRNs)

The Cognitive Radio Networks (CRNs) architecture is shown in Figure 2.3 [24]. The components of the architecture can be widely categorized in two groups, the primary network and the secondary

network [5]. The primary network is the existing network infrastructure. In the existing infrastructure, some spectrum bands are licensed (for example, cellular network, TV broadcast networks) and some other bands are unlicensed. Licensed band users have exclusive right to their spectrum band and are called primary users (PUs). Primary users' access to their licensed band is supervised by the primary base stations and these users require no adaptation to include in cognitive radio networks architecture.

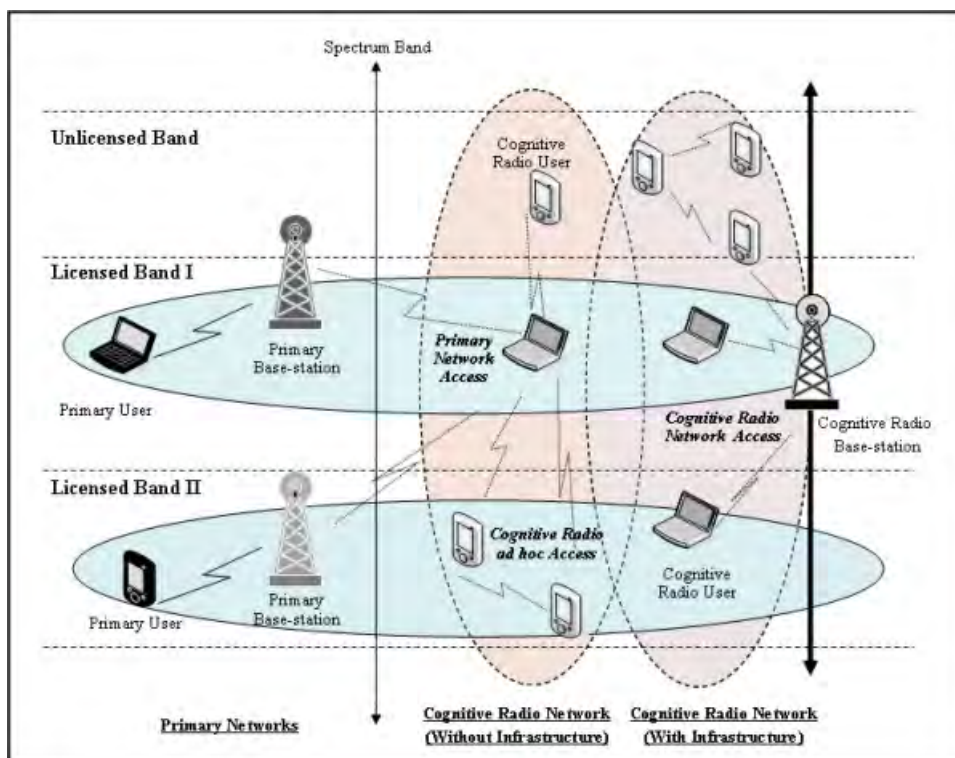

Figure 2.3: Cognitive radio networks architecture

The secondary network is also known as dynamic spectrum access network, unlicensed network, xG network, and cognitive radio network [5]. The users of this network contains no license to use the spectrum band and are called secondary users (SUs). These users employ cognitive radios to opportunistically exploit temporal spectrum holes. The secondary network can operate under the provision of secondary base stations or just work in an ad hoc manner. Another important component of cognitive radio networks is a central network entity called spectrum broker that works as a spectrum information manager to maintain the coexistence of multiple cognitive radio networks [5, 25, 26, 27].

2.3 Applications of CRNs

The unconventional architecture of cognitive radio networks exhibits a potential to be utilized in several applications including high-speed rural Internet infrastructure development [28], military networks [29], emergency networks [30], leased networks [31], and cognitive mesh networks [32]. For example, California based Carlson wireless technologies markets cognitive radio enabled RuralConnect device [33]. This device exploits TV white space to deliver high speed Internet connectivity to rural people. It can also be deployed in densely populated areas with significant spectrum contention.

Military networks is another significant applications of CRNs. CRNs support military radios' requirements of choosing any random frequency, modulation and coding techniques, and adaptation to the changing battle-field environment [5]. Emergency networks in the times of natural disasters can be established using CRNs. CRNs establishes such emergency networks by enabling data communication over existing spectrum without installing any new infrastructures [30].

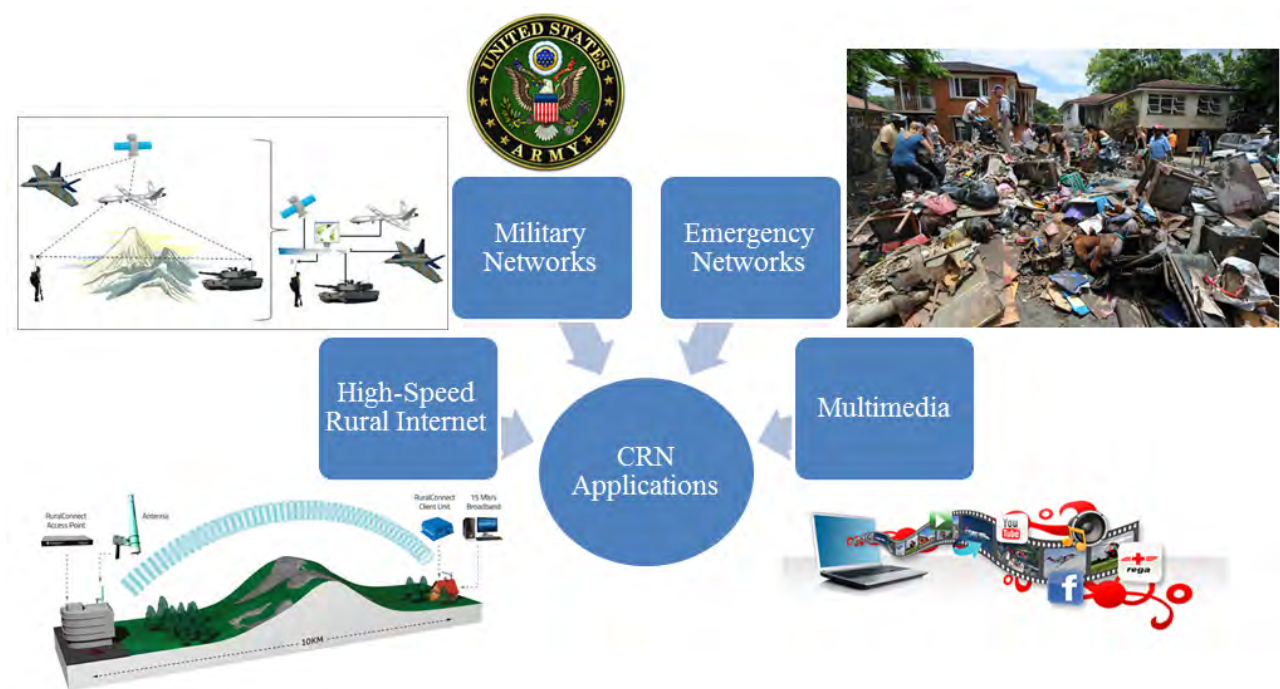

Figure 2.4: Applications of cognitive radio networks

2.4 Multi-Radio Networks

The price of RF transceivers has rapidly reduced in the last few years [34]. This price reduction has prompted to install multiple low-cost radios in a single node of wireless networks [35]. Such networks are known as multi-radio networks. These multi-radio networks impose unique research challenges due to the nature of two conflicting objectives: channel diversity and node connectivity [36]. Multiple radios on a single node enables simultaneous multiple channel access which results in improved network capacity. On the contrary, the transmitter and the receiver must be adjusted to the same channel to maintain network connectivity. Consequently, common control radio based protocols has been proposed in the recent literature to address these challenges [37, 38, 39, 40, 41].

One of significant advantage of installing multiple radios on a single node in multi-radio networks is the network performance improvement through parallel spectrum access. On the other hand, the basic motivation behind using cognitive radio networks is also to improve network performance through opportunistic dynamic spectrum access. Therefore, these two paradigms are combined into another network architecture, multi-radio cognitive radio networks.

2.5 Multi-Radio Cognitive Radio Networks (MRCRNs)

In multi-radio cognitive radio networks, secondary users are equipped with multiple transceivers. This enables secondary users to increase spectrum access just like any multi-radio networks. Moreover, the channel switching time for cognitive radio networks is also reduced as illustrated in Figure 2.5. Secondary users have to vacate their currently used channel when the channel's licensed primary user becomes active. This results into secondary users looking for another free channel and switching into that free channel. Secondary users equipped with multiple radios can exploit their additional radios to reduce this switching delay. Due to these advantages, several studies have investigated the various research problems in MRCRNs. In next section, we will survey the existing research works on MRCRNs.

2.6 Existing Studies on MRCRNs

Existing studies on MRCRNs mainly investigate how to incorporate multiple radios in dynamic spectrum sharing scenario. These studies mainly propose medium access control protocols [42, 16], routing

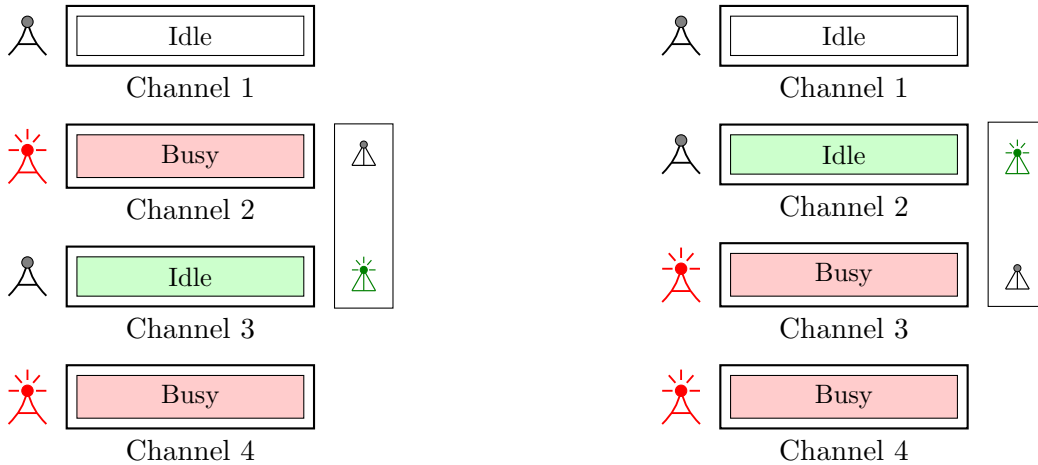

Figure 2.5: Secondary users (SUs) equipped with multiple radios experience reduced switching delay

protocols [43, 17], and channel assignment [44, 2] for MRCRNs. Zhu et al., present a spectrum-tree based on-demand routing protocol that considers multi-radio nodes [43]. Such nodes belong to multiple spectrum-trees and are called overlapping nodes. As these nodes simultaneously work in different spectrum-trees, they can be used for inter-spectrum routing. The study shows that the proposed approach significantly reduces the average end-to-end delay. Besides, Feng et al., propose a novel spectrum handoff scheduling approach for multi-hop MRCRNs [17]. This study presents a routing protocol with the help of aging-based priority assignment to minimize the latency. Thus none of these approaches addresses the problem of overcoming throughput degradation problem in MRCRNs.

Ahmadi et al., present one of the earliest CRN studies involving multiple radios, which considers two sender radios for each secondary user [44]. They propose a distributed channel assignment approach for cognitive radio networks. Their CRN node structure employs multiple radios to efficiently use multiple available channels. While assigning channels, the study considers primary user's sudden arrival and interference. Moreover, secondary users' interference on each other is also considered to minimize the disconnection time. They also propose a collaborative channel sensing mechanism.

Even though, this study strives to solve channel assignment problem for the scenario, there is only one receiver radio for each user in the proposed network model. As channels are assigned to the receiver radio, the corresponding channel assignment problem becomes close to the single-radio channel assignment problem. This is because, as in single-radio scenario, only one channel needs to be assigned for each receiver node and the node can not exploit multiple available channels while receiving packets. Further, the study always uses a fixed number of transmitter radios (two) and do

not investigate performance of the network for varying numbers of radios.

Another MRCRN study [2] by Zhong et al., mainly focuses on capacity analysis of the secondary network to analyze the cognitive radio networks' performance limits. Their capacity analysis is based on small world model of the secondary network [45]. Based on this small world model, they propose a channel assignment algorithm considering the available time and the transmission time of the channels. The difference between a channel's available time and transmission time is used to rank the corresponding channel. While assigning channels, the secondary users form shortcuts defining a logical link between a pair of nodes.

Although, the study aims to solve the channel assignment problem for MRCRNs and the proposed channel assignment approach assigns multiple channels among multiple radios available for secondary users, while assigning ranked channels among radios, the approach does not consider the state of those radios. Besides, the paper does not provide any analysis on throughput with an increase in the number of radios.

The analysis of any performance metric based on an increase in the number of radios in CRNs is first presented in the study [12] by Li et al., to the best of our knowledge. The study presents a rendezvous channel establishment approach for MRCRNs. It shows that the maximum time to rendezvous reduces with an increase in the number of radios used in CRNs. However, the study does not provide any solution on how these radios will be used for data transmission and its subsequent effect on performance metrics such as throughput and delay.

Later, Khan et al., [1] propose another MRCRNs architecture where each secondary user employs multiple radios for data transmission. The study shows that per packet average end-to-end delay gets improved at the cost of throughput degradation with an increase in the number of radios. This study does the radio-channel assignment in a random manner and does not avoid inter-user channel interface. Thus, this study fails to improve throughput with an increase in the number of radios.

In summary, none of the existing studies focuses on enhancing throughput in MRCRNs. Therefore, we attempt to propose a new channel assignment approach to enhance throughput in MRCRNs in this thesis. Before presenting the approach, we first elaborate our system model and problem formulation.

Chapter 3

System Model and Problem Definition

In this chapter, we introduce the system model of a Multi-Radio Cognitive Radio Network (MRCRN). Additionally, we list down several assumptions for the system model. For this system model, we then define our research problem.

3.1 System Model

We consider a cognitive radio network (as described in Figure 3.1) having n primary users and m secondary users in our analysis. For the sake of simplicity, we assume that n primary users use n distinct spectrum channels. Primary users randomly become active and inactive in their respective channel following a Poisson process [46]. Dedicated single PU for a single channel can actually model multiple PUs per channel. Also, when PU becomes active, SUs' transmission is held back instantly. Therefore, PUs do not refrain from using their dedicated channel. In our considered system model, the primary user sensing is done via a pre-installed primary user database [47]. This database stores the various primary user information such as location, activity start and stop times, and power.

According to the network infrastructure, our considered cognitive radio network model can be identified as cognitive radio ad hoc networks (CRAHNs) [48]. We are not considering the infrastructure-based cognitive radio network as such networks have a central authority. In case of the infrastructure-based cognitive radio networks, the overall assessment of the environment is sent to the central authority by each individual user. Based on these assessments, the central authority can take decisions to improve the overall network performance. On the contrary, taking these decisions in case of CRAHNs is more challenging due to the absence of such a central authority.

As CRAHNS do not have any central authority, such networks require a dedicated control channel to interchange messages [48]. Therefore, in our considered system model, each of the m secondary users has at least 2 radios; one radio is for control purpose, and remaining ones are for data communication and channel sensing activities. There is a dedicated control channel for the control radios, which we assume not to be used by any of the primary users. For control channel, recent studies [49, 50, 51] have proposed several strategies to establish a control channel via channel hopping when there is no PU free channel in the system model. Therefore, we can assume such methods can be adopted to establish a control channel for our system model when no primary user free channel is available.

This dedicated control channel is utilized into time slots. Each time slot has m sub-slots, one for each of the secondary users. In each sub-slot, the respective secondary user's control radio transmits its current communication parameters to avoid hidden terminal and synchronization problems. We assume that there is no inter-channel interference among the data channels. Also, we only consider single-hop data communication for secondary users.

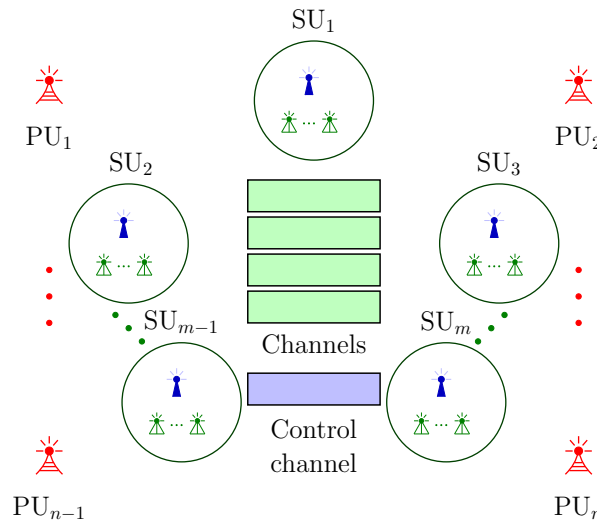

Figure 3.1: System model of a MRCRN

3.2 Problem Definition

Under the presented system model, our research question is how to efficiently use the available multiple data transmission radios to get enhanced total network throughput while limiting end-to-end delay. As there is no central authority in the considered system model, solution of the problem must be distributed. Besides, the decision making must also be online as the primary and secondary users'

behavior can dynamically vary, and thus can not be predicted beforehand. Considering these aspects, we propose a solution in the next chapter.

Chapter 4

Feedback-based Multi-radio Exploitation Approach

Our proposed approach consists of mainly two different types of feedbacks. Firstly, we measure packet transmission ratio for each radio to evaluate radio performance. Secondly, we calculate channel utilization ratio for each channel to assess corresponding channel condition.

4.1 Overview of The Proposed Approach

We present a brief overview of our proposed feedback-based approach in fig. 4.1. Our proposed approach starts operating whenever a Transport layer packet is received on the Data Link layer. The Transport layer packets enter via `sendPacket` function of our proposed SU agent. As SUs are equipped with multiple radios, a single radio is first selected to send the transport layer packet. The radio selection process as described in section 4.2 is based on packet transmission ratio. After the radio is selected, the transport layer packet is enqueued on the corresponding radio's queue. When the packet is dequeued from the radio's queue to be transmitted over the spectrum, the radio starts sensing the PU activity on its current channel. If the current channel is idle, it transmits the packet following an standard CSMA-CA protocol. However, if the current channel is busy, then the radio selects another channel and starts switching to that channel. The channel selection process is based on channel utilization ratio and is described in section 4.3.

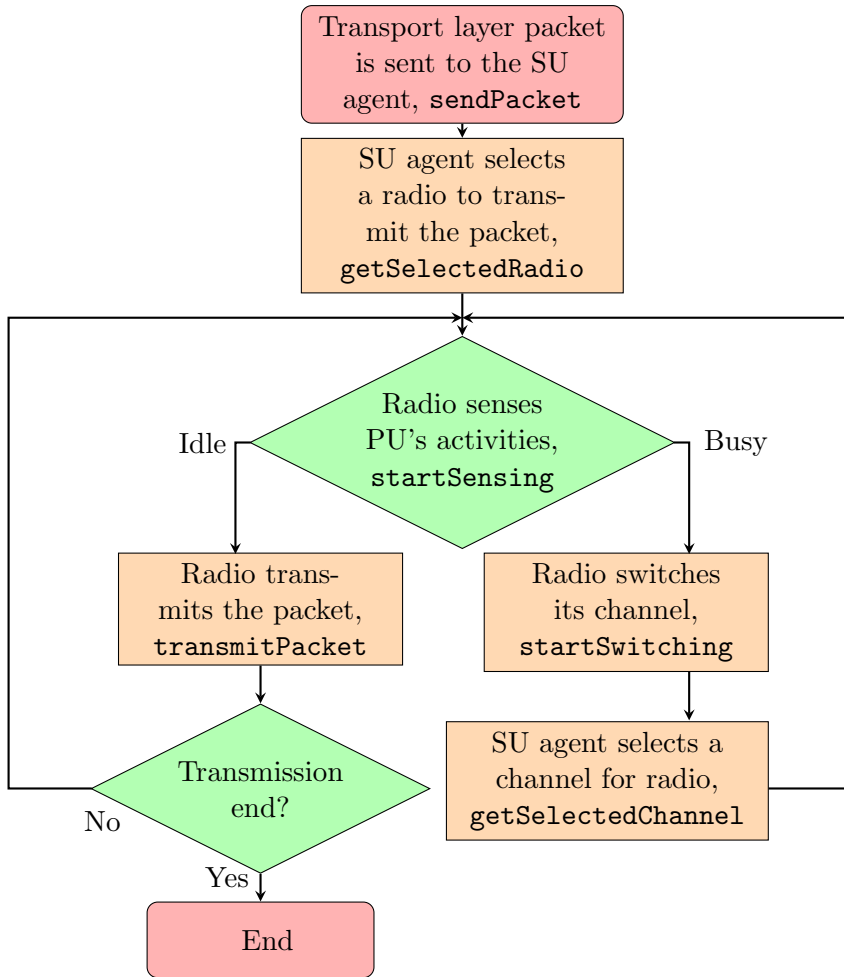

Figure 4.1: High-level overview of the proposed approach

4.2 Radio Selection Based on Packet Transmission Ratio

When SUs are equipped with multiple data transmission radios, the first issue comes into play is to select the radio for transmitting data packets. For this selection, our proposed approach maintains two counters for each radio namely `pktQueued` denoting the number of packets queued for the radio and `pktSent` denoting the number of packets already transmitted by the radio. Whenever the Application layer of an SU sends a packet for transmission to the lower layers, the secondary user agent calculates the ratio between `pktSent` and `pktQueued` for each radio. We define the ratio as Packet Transmission Ratio, `sentQueuedRatio`. Subsequently, we normalize values of the ratio to rank the radios in a uniform manner. A larger value of such packet transmission ratio implies that the corresponding radio

has been successful to transmit more packets than others. Using these packet transmission ratios as the weights, our proposed approach conducts a weighted lottery to select radios for transmission of packets.

At the beginning of the packet transmission process, an SU's radio senses its current channel. If the cognitive radio finds that the current channel is busy, then the radio starts a channel switching process. At the beginning of the channel switching process, the SU agent lists all the channels currently not used by any radio of the corresponding SU. If no such channel can be found, the radio is reported as Off and the queued packets are discarded as dropped. Otherwise, a channel is selected from the list of available channels, `availableChannels` based on current channel utilization ratio. We present the selection process along with the definition of the channel utilization ratio next.

4.3 Channel Selection Based on Channel Utilization Ratio

In our proposed approach, each SU keeps two counters for each channel. First, `pktTransmitted` counts the number of packets transmitted in the channel by the corresponding SU radios. Besides, `pktReceived` counts the number of packets successfully received by the corresponding receiver. The counter, `pktReceived` is incremented after reception of each acknowledgment packet. When a switching radio requires selecting a channel among `availableChannels`, the SU agent calculates the ratio between `pktReceived` and `pktTransmitted` for each channel on the list, `availableChannels`. We define the ratio as Channel Utilization Ratio, `RxTxRatio`. We normalize this ratio to rank the channels in a uniform manner. Using these channel utilization ratios as the weights, the SU agent conducts a weighted lottery to select the channel to switch over.

The last two important aspects of our feedback-based multi-radio exploitation approach are the reactivation of Off radios and probabilistic channel switching. Radios marked Off at the beginning of a channel switching process, are reactivated probabilistically by the radio selection process. While calculating packet transmission ratio from `pktSent` and `pktQueued`, in the case of Off radios, the ratio is multiplied by `wakeUpProbability` to make it less likely to be selected as the next radio for sending a packet. Though, if selected, the Off radio is reported as On and it starts its cognitive cycle through the channel sensing process. The probabilistic channel switching implies that radios do not always switch after finding their current channel busy. The channel switching process occurs at a probability of `switchingProbability`.

Algorithm 1 *sendPacket*: SU agent sending a packet, p

```

1: function sendPacket
2:    $radioIndex \leftarrow getSelectedRadio()$ 
3:    $pktQueued[radioIndex] \leftarrow$ 
      $1 + pktQueued[radioIndex]$ 
4:    $radioStatus[radioIndex] \leftarrow On$ 
5:    $startSensing(radioIndex)$ 

```

Algorithm 2 *startSensing*: SU's radio sensing its channel

```

1: function startSensing( $radioIndex$ )
2:   if  $currentChannel[radioIndex]$  is Busy then
3:      $startSwitching(radioIndex)$ 
4:   else
5:      $transmitPacket(radioIndex)$ 

```

Algorithm 3 *startSwitching*: SU's radio changing its channel

```

1: function startSwitching( $radioIndex$ )
2:   Stop the switching process and return with the probability  $(1 - switchingProbability)$ 
3:    $availableChannels \leftarrow$  all the channels currently not used by any radio of the SU
4:   if  $availableChannels = \emptyset$  then
5:      $radioStatus[radioIndex] \leftarrow Off$ 
6:      $dropPacket()$ 
7:   else
8:      $channelIndex \leftarrow$ 
        $getSelectedChannel(availableChannels)$ 
9:      $currentChannel[radioIndex] \leftarrow channelIndex$ 
10:     $channels[channelIndex] \leftarrow Used$ 
11:     $startSensing(radioIndex)$ 

```

Algorithm 4 *transmitPacket*: SU's radio transmitting a packet, p

```

1: function transmitPacket( $radioIndex$ )
2:    $pktSent[radioIndex] \leftarrow pktSent[radioIndex] + 1$ 
3:    $pktTransmitted[currentChannel[radioIndex]] \leftarrow$ 
      $pktTransmitted[currentChannel[radioIndex]]$ 
      $+ 1$ 
4:   encapsulate  $radioIndex$  within the packet,  $p$  and transmit it following CSMA-CA

```

Algorithm 5 *receiveAckPacket*: SU's radio receiving an Ack packet, p

```

1: function receivePacket( $p$ )
2:    $radioIndex \leftarrow$  the radio index extracted from the packet
3:   if  $radioIndex =$  current radio's index then
4:      $pktReceivedRadio[radioIndex] \leftarrow$ 
        $pktReceivedRadio[radioIndex] + 1$ 
5:      $pktReceived[currentChannel[radioIndex]] \leftarrow$ 
        $pktReceived[currentChannel[radioIndex]] + 1$ 

```

Algorithm 6 *getSelectedRadio*: Selects an SU radio to send a packet

```

1: function getSelectedRadio
2:    $k \leftarrow$  the number of radios
3:    $sentQueuedRatio[0 \dots k] \leftarrow$  a new array of floating point values
4:    $total \leftarrow 0.0$ 
5:   for  $r = 1$  to  $k$  do
6:      $sentQueuedRatio[r] \leftarrow \frac{(1 + pktSent[r])}{(1 + pktQueued[r])}$ 
7:     if  $radioStatus[r] = Off$  then
8:        $sentQueuedRatio[r] \leftarrow$ 
9:          $sentQueuedRatio[r] \times wakeUpProbability$ 
10:     $total \leftarrow total + sentQueuedRatio[r]$ 
11:   for  $r = 1$  to  $k$  do
12:      $sentQueuedRatio[r] \leftarrow \frac{sentQueuedRatio[r]}{total}$ 
13:    $radioIndex \leftarrow$  winner of the weighted lottery among all the radios with weight,
     $sentQueuedRatio$ 
14:   return  $radioIndex$ 

```

Algorithm 7 *getSelectedChannel*: Selects a new channel to switch for an SU radio over the *availableChannels*

```

1: function getSelectedChannel(availableChannels)
2:    $k \leftarrow$  the number of channels in availableChannels
3:    $RxTxRatio[0 \dots k] \leftarrow$  a new array of floating point values
4:    $total \leftarrow 0.0$ 
5:   for  $r = 1$  to  $k$  do
6:      $RxTxRatio[r] \leftarrow \frac{(1 + pktReceived[r])}{(1 + pktTransmitted[r])}$ 
7:      $total \leftarrow total + RxTxRatio[r]$ 
8:   for  $r = 1$  to  $k$  do
9:      $RxTxRatio[r] \leftarrow \frac{RxTxRatio[r]}{total}$ 
10:   $channelIndex \leftarrow$  winner of the weighted lottery among all the channels in availableChannels
    with weight,  $RxTxRatio$ 
11:  return  $channelIndex$ 

```

4.4 Sequential Radio and Channel Selection

An important characteristic of our proposed feedback-based multi-radio exploitation approach is the sequential radio and channel selection instead of jointly optimized radio-channel selection. In our approach, when transport layer packets come in the data link layer, our SU agent enqueue them to one of the available radio's queue. Our packet transmission ratio based radio selection algorithm (Section 4.2) determines that on which radio's queue each packet will be enqueued. During this time, the channel through which this packet will be transmitted is not decided. The channel selection decision is made later when the packet is dequeued from the radio's queue. At that time if the radio senses no primary user on the radio's currently assigned channel, the dequeued packet is transmitted using the currently assigned channel. Only if the radio's sensing results show that there is primary user activity of the current channel, the radio switches from the current channel, only then the channel selection algorithm is used to find the new channel.

The reason behind this sequential radio and channel selection is the dynamic nature of cognitive radio networks. When the packets are enqueued in the radio, neither the actual time when any of these packets will be transmitted nor the channels' state at that time can be accurately predicted. Therefore, any jointly optimized radio-channel selection could not consider the actual channel condition at the time of packet transmission. Keeping this issue in mind, our proposed approach employs sequential radio and channel selection process.

4.5 Weighted Lottery Mechanism

Since we select radio and channel for packet transmission through weighted lottery, the details of such an weighted lottery is described in this section. For example, let us assume the radio selection probabilities of four radios at an SU are 0.1, 0.2, 0.3, and 0.4. In our proposed approach, we then randomly select a floating point value, x uniformly within the range $[0, 1]$. If the value of this random floating number, x is less than or equal 0.1 ($0.0 < x \leq 0.1$), we select the first radio. Similarly, if $0.1 < x \leq 0.3$, we select the second radio, if $0.3 < x \leq 0.6$, we select the third radio, and if $0.6 < x \leq 1.0$, we select the fourth radio. Such an weighted lottery based mechanism has previously been proposed in the fields of statistics [52] and scheduling algorithms [53].

Table 4.1: Several variants of the proposed feedback-based approach

| Variant name | Radio selection policy | Channel selection policy |
|------------------------|--|---|
| Radio feedback | Weighted lottery based on radio transmission ratio | Unweighted lottery |
| Channel feedback | Unweighted lottery | Weighted lottery based on channel utilization ratio |
| Radio channel feedback | Weighted lottery based on radio transmission ratio | Weighted lottery based on channel utilization ratio |

4.6 Variants of Our Proposed Approach

We create three variants of our proposed approach introducing radio and channel selection based on a random variable following a uniform distribution. While selecting the next radio for data packet transmission, we can randomly select any one of data radios with equal selection probability ignoring the packet transmission ratios. Similarly, the next channel to switch can also be chosen randomly from the available channels with equal selection probability irrespective of the channel utilization ratio. We define this random radio and channel selection policy as unweighted lottery. From this unweighted lottery, we devise three variants of our proposed approach as described in table 4.1. The approach of randomly selecting both the radio and the channel has not be listed as the variants of the proposed approach as that approach is quite similar to the approach proposed by Zhong et al., [2].

Chapter 5

Experimental Evaluation

Our proposed system requires wireless devices with multiple networking interface modules. Each of these modules must also have cognitive capability to ensure the basic requirements of our proposed architecture. The development of such devices involves a highly complex level of sophistication and fabrication. Such a development of cognitive radio networks in real setup is still under research. Therefore, we evaluate the performance of our proposed feedback-based multi-radio exploitation approach through extensive discrete-event simulation using `ns-3`. Yet, we have to make several modifications on the `ns-3` simulator to evaluate our proposed approach on MRCRNs.

5.1 Simulator Modifications

We implement our proposed approach on top of the Cognitive radio extension for `ns-3` namely CRE-NS3 [54]. We modify the cognitive module of CRE-NS3 to incorporate our feedback-based approach. The existing cognitive module of CRE-NS3 provides three interfaces for each device namely control interface, transmitter interface, and receiver interface. The transmitter and receiver interfaces of the module emulate a real cognitive transceivers. Therefore, we introduce the functionality of varying number of cognitive transceivers through varying the number of the transmitter and receiver interfaces.

To implement this functionality, we utilize the `Callback` mechanism of `ns-3` extensively. Using this mechanism, we make sure that our counters (`pktQueued`, `pktSent`, `pktTransmitted`, and `pktReceived`) are incremented after corresponding events. The `Callback` mechanism has also been used to update `radioStatus`, `availableChannels`, and `currentChannel` lists.

We also employ `ns-3` flow tagging feature, `FlowIdTag` to encapsulate and extract extra infor-

mation to and from packets. As multiple radios on a single SU node share the same upper layer address (IP address), the extra `FlowIdTag` of each packet determines the radio reference (sender and receiver), using which upper layers can distinguish among multiple radios. Moreover, we add `DelayJitterEstimationTimestampTag` to each packet to calculate delay each packet experiences.

Apart from these changes, we have also made several changes in the `wifi` module of the `ns-3` simulator. Specifically, we have modified the `YansWifiPhy`, `YansWifiChannel`, `WifiPhyStateHelper`, `RegularWifiMac`, and `WifiNetDevice` models of the `wifi` module to add the cross-layer implementation of the multi-radio functionality.

Using the modified simulator, we implement our proposed approach and evaluate its performance on the basis of four performance metrics – total network throughput, end-to-end delay, packet drop ratio, and application layer packet delivery ratio. Besides, we measure values of these metrics for two existing MRCRN protocols and compared them against that obtained using several variants of our proposed approach. We briefly describe our simulation settings next before presenting the evaluation results.

5.2 Simulation Settings

We consider that arrival and departure of a PU follow a Poisson process [55]. Accordingly, we consider an exponential distribution for both inter-arrival time and service time. Hence we adopt the mean time between two successive arrivals to be 5 seconds and the mean service time to be 2 seconds. Besides, we consider that each secondary user enables a constant bit rate application where the data transmission rate is varied from 1 Mbps to 32 Mbps. Here, each secondary user is equipped with a variable number of radios. Each of the radios consists of one transmitter interface and one receiver interface. The transmitter interface transmits data over any of the eleven orthogonal channels that conventionally operate with OFDM WiFi mode having 18Mbps data rate. For each transmitter interface or radio, we associate a drop-tail queue with a maximum capacity of 100 packets, each of 1KB in size. These interfaces have a transmission range of 130m and a sensing range of 250m. To ensure that the destination users are reachable from the source users, we place the destinations at an average distance of 80m from the sources. Maintaining such average distance, primary users and secondary users are placed randomly in an area of 500m×500m. Here, we vary the number of secondary users from 12 to 40 with a granularity of 4. For each such settings, we perform 99 simulation iterations and then

take average results of all the iterations. It is to be noted here that the maximum iteration count for obtaining 95% confidence interval according to Monte Carlo Sampling [56] is found to be 61 in our experiment settings. As our initial simulation results shows that almost all the performance metrics become constant after 40-50 seconds (as shown in Figure 5.1), each iteration of our simulation is 50 seconds long.

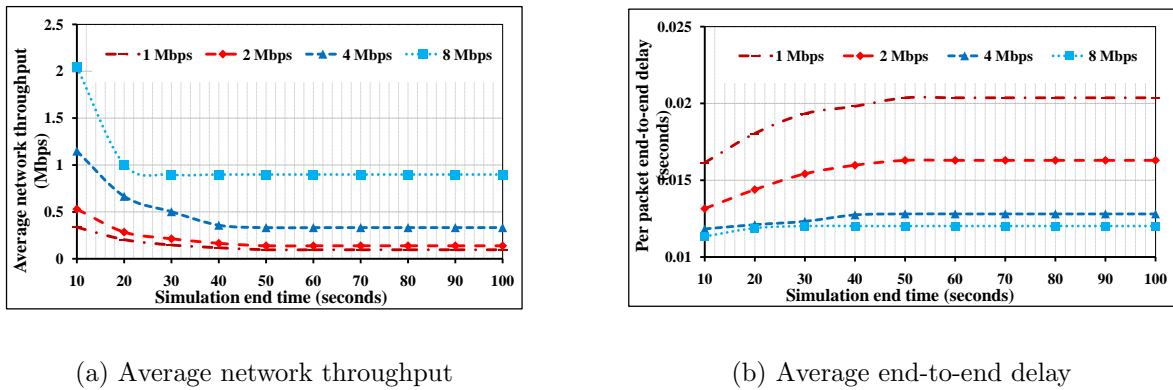

(a) Average network throughput

(b) Average end-to-end delay

Figure 5.1: Average network throughput and end-to-end delay with varying simulation end time

We carefully set the tuning parameters of the proposed approach after numerous simulation trials. The channel switching probability of SU radios, `switchingProbability` was varied from 0.1 to 0.9 with a granularity of 0.05 and the reactivation probability of switched-off radios, `wakeUpProbability` was varied from 0.05 to 0.5 with a granularity of 0.05. Following these initial simulation results, we selected the value of these parameters that yielded best results in terms of throughput, delay, and packet drop ratio. In future, we aim to incorporate dynamic value selection of these parameters so that their values are updated on run time based on feedback from different performance metrics such as throughput, delay, and packet drop ratio. For the time being, we have fixed these parameters based on initial simulation results. The `switchingProbability` is set as 0.75 and the `wakeUpProbability` is set as 0.2. The channel sensing time for each of the cognitive radio is set as 0.01s while the channel switching time is set as 0.05s.

5.3 Results and Analysis

We start presenting our simulation results for a topology having 11 primary users and 24 secondary users. Here, we vary the application data rate from the source of a flow over secondary users from

1 Mbps to 32 Mbps. Fig. 5.2, 5.3, and 5.4 show the performance of several variants of our proposed approach and other existing approaches.

Fig. 5.2 depicts total network throughput for all the approaches in response to a variation in the number of radios for different application data rates. In most of the cases, our proposed approaches obtain significantly higher network throughput than the existing ones. Here, at lower data rates (1-8 Mbps), total network throughput increases with an increase in the number of radios. After reaching an optimal point, throughput starts degrading. At higher data rates (16 and 32 Mbps), the network throughput falls drastically from the single radio scenario and never again reaches the throughput obtained with single radio data transmission.

Fig. 5.3 illustrates that the feedback-based approaches experience significantly lower end-to-end delay than that achieved with the approach proposed by Zhong et al. [2]. However, delay using our proposed approach is higher than that achieved with the approach proposed by Khan et al. [1]. Here with our proposed approach, the delay becomes almost constant with an increase in the number of radios at lower application data rates (1-4Mbps). However, at higher data rates (8-32 Mbps), the delay rises with an increase in the number of radios per SU.

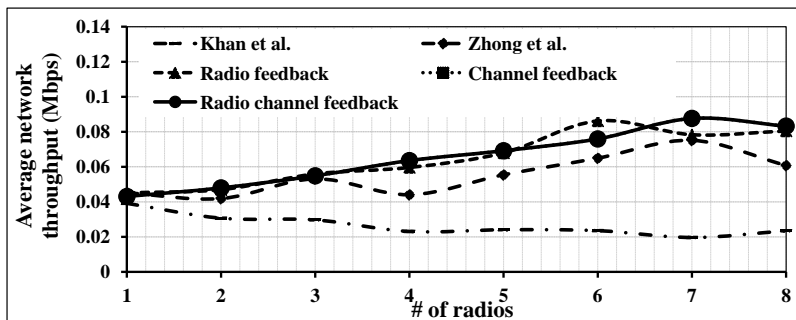

(a) 1Mbps application data rate

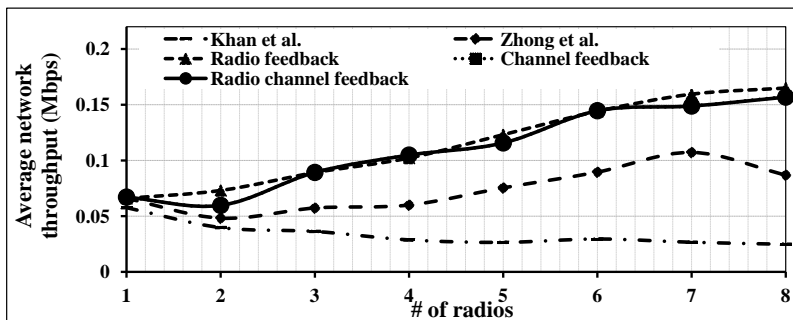

(b) 2Mbps application data rate

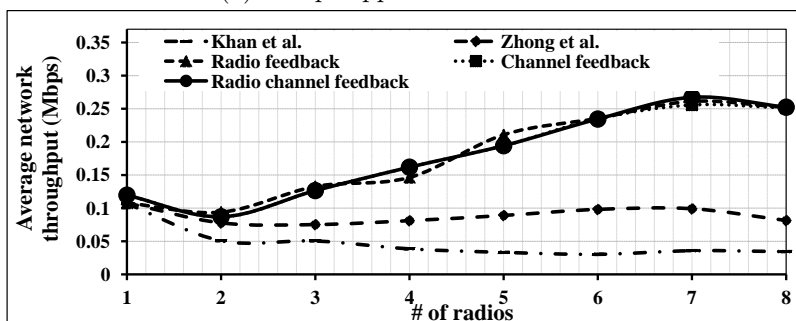

(c) 4Mbps application data rate

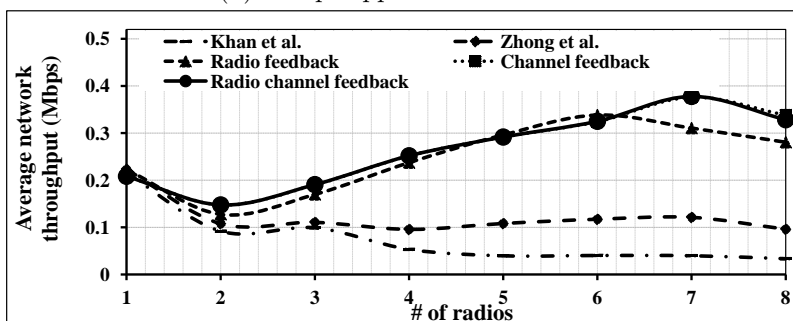

(d) 8Mbps application data rate

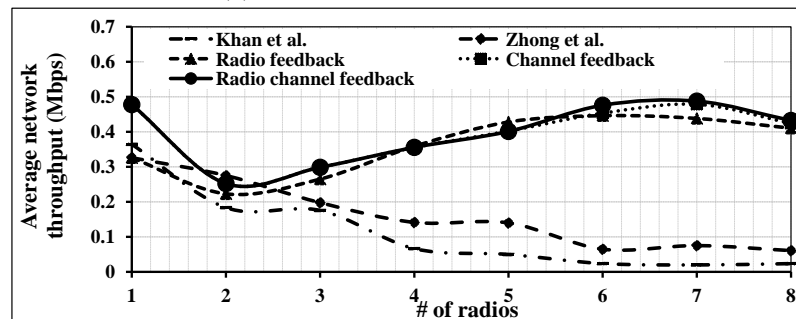

(e) 16Mbps application data rate

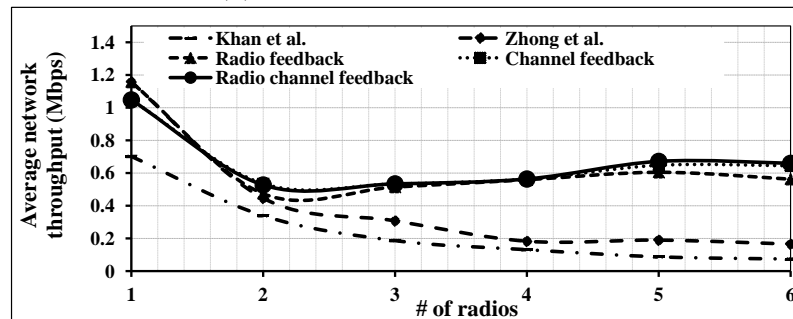

(f) 32Mbps application data rate

Figure 5.2: Average network throughput with varying number of radios for various application data rates

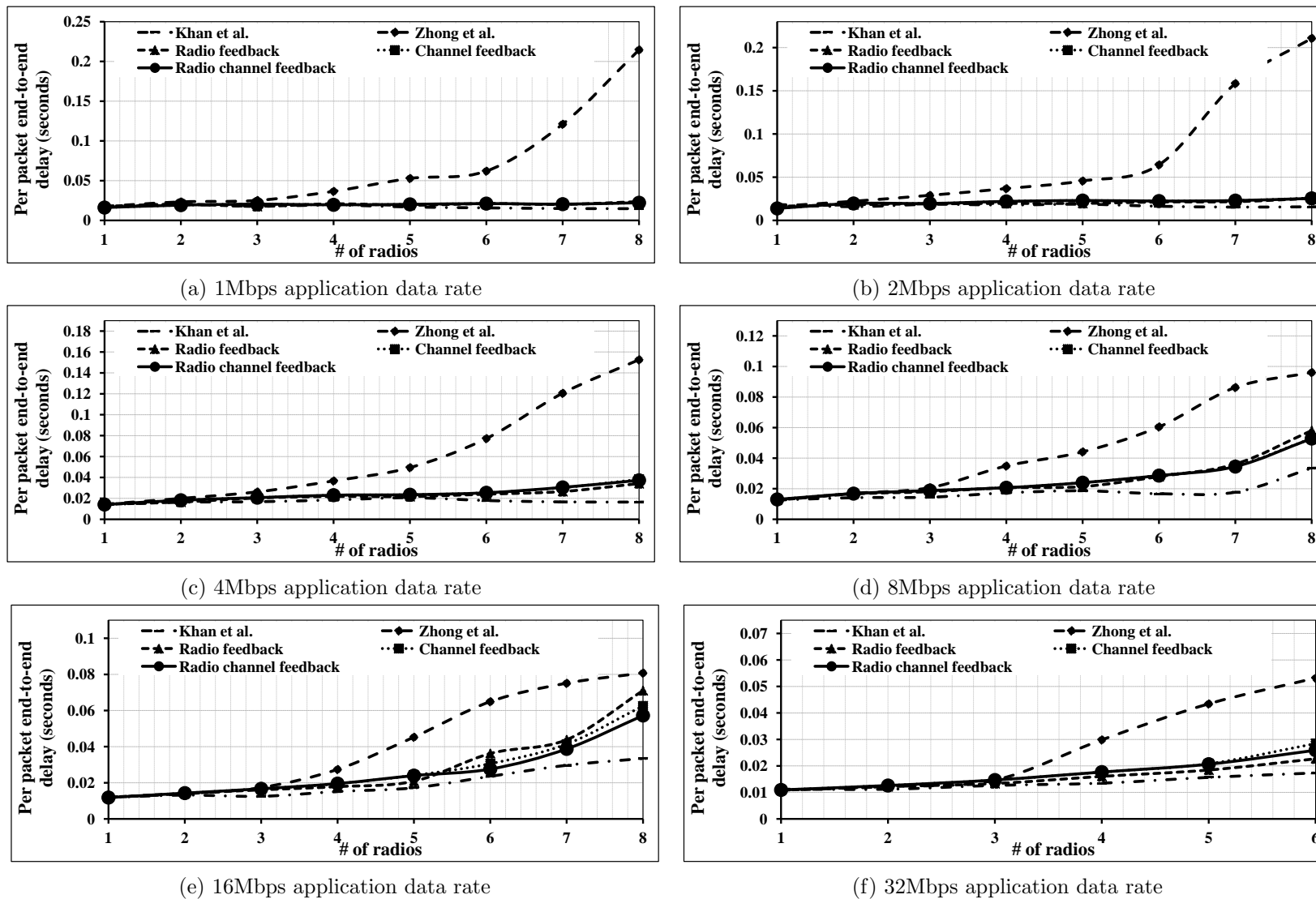
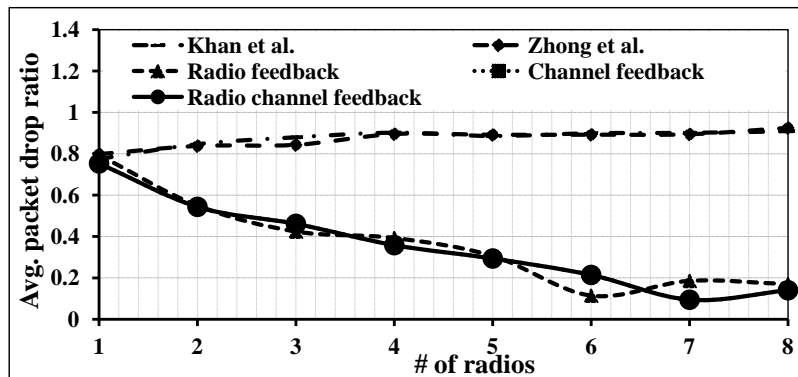
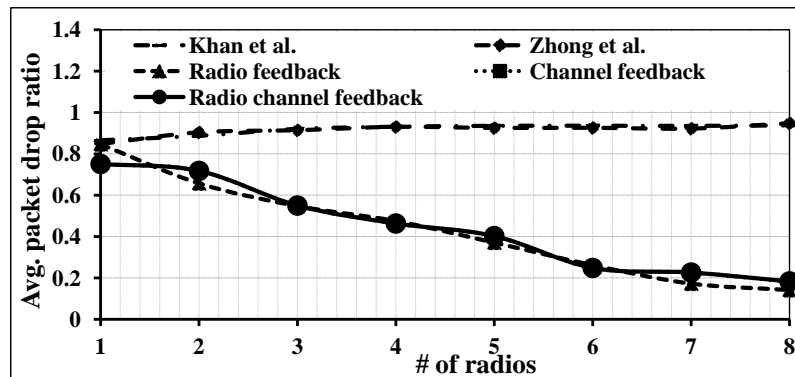

Figure 5.3: Average end-to-end delay with varying number of radios for various application data rates



(a) 1Mbps application data rate



(b) 2Mbps application data rate

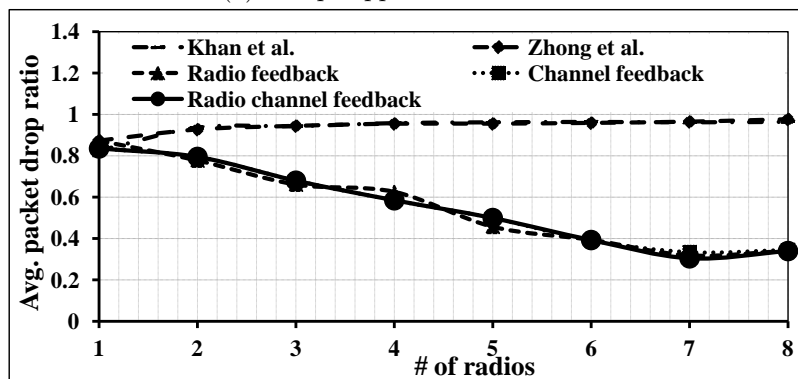

(c) 4Mbps application data rate

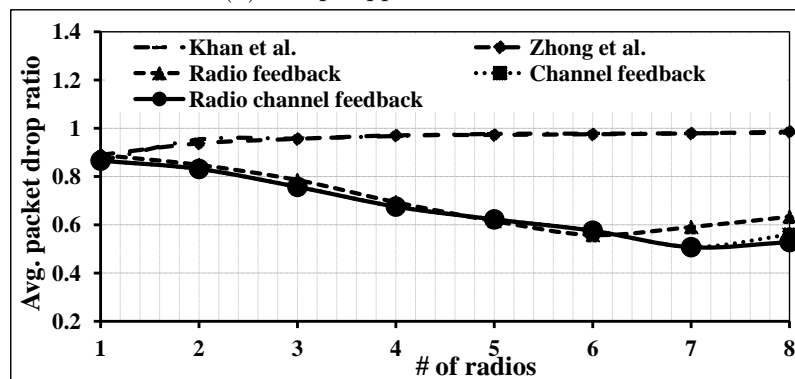

(d) 8Mbps application data rate

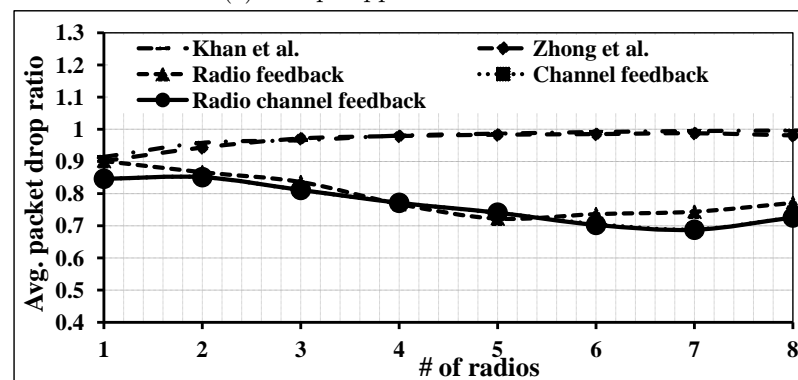

(e) 16Mbps application data rate

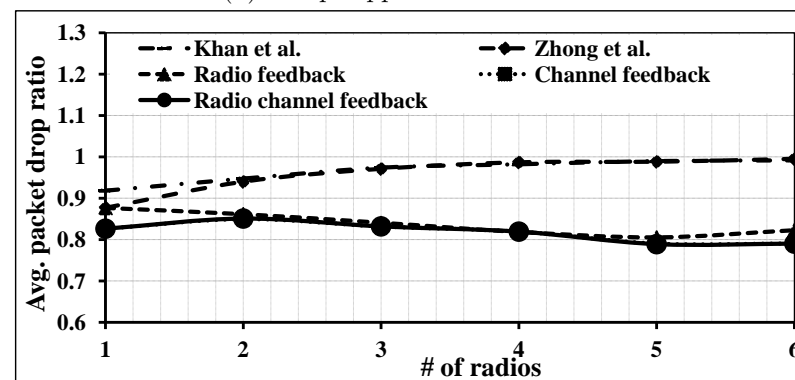

(f) 32Mbps application data rate

Figure 5.4: Average packet drop ratio with varying number of radios for various application data rates

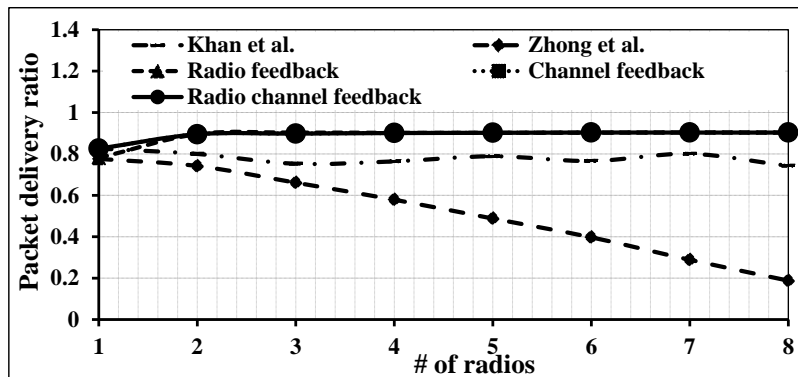

(a) 1Mbps application data rate

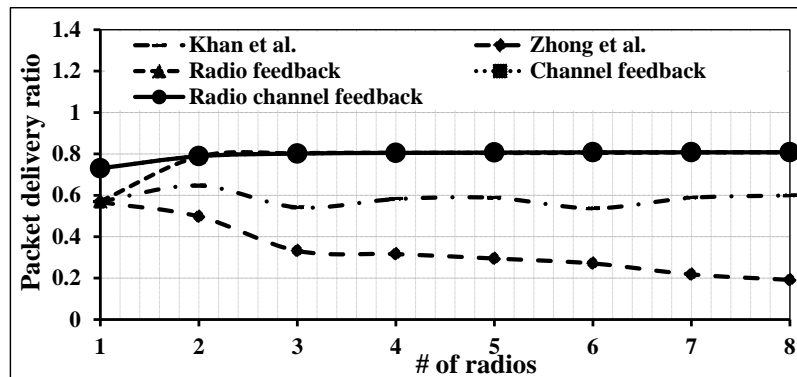

(b) 2Mbps application data rate

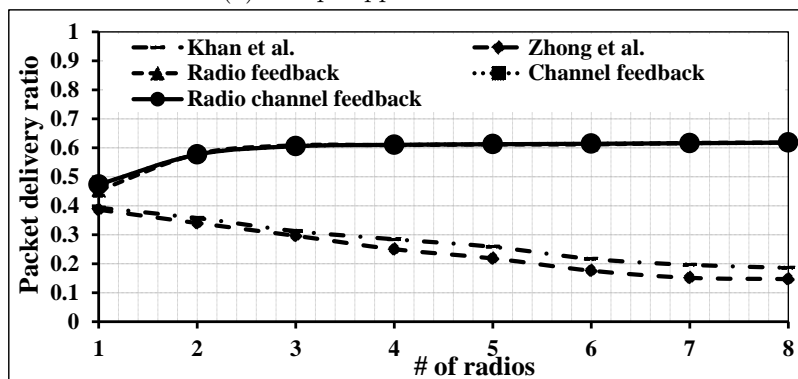

(c) 4Mbps application data rate

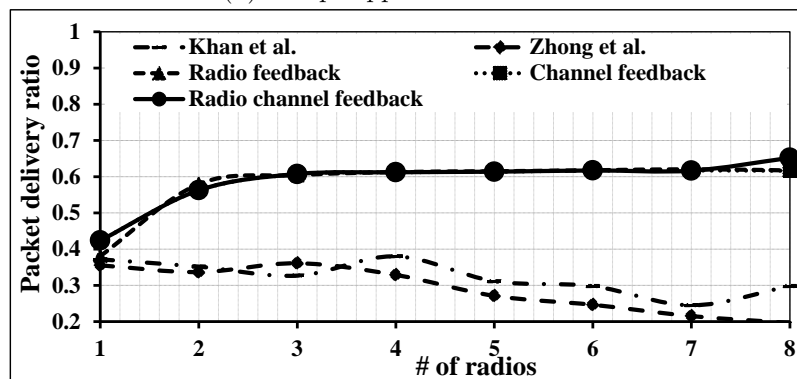

(d) 8Mbps application data rate

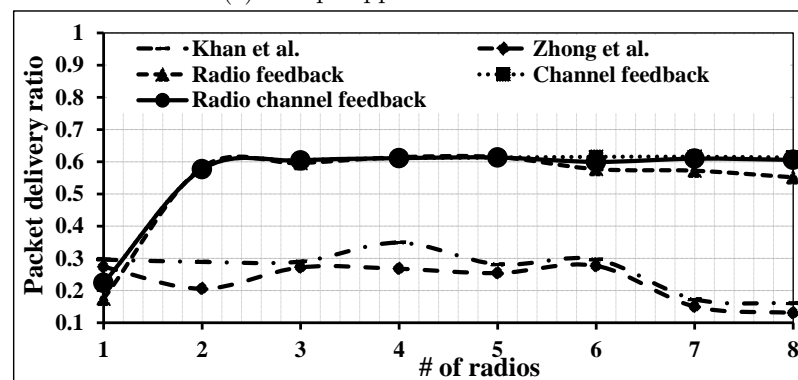

(e) 16Mbps application data rate

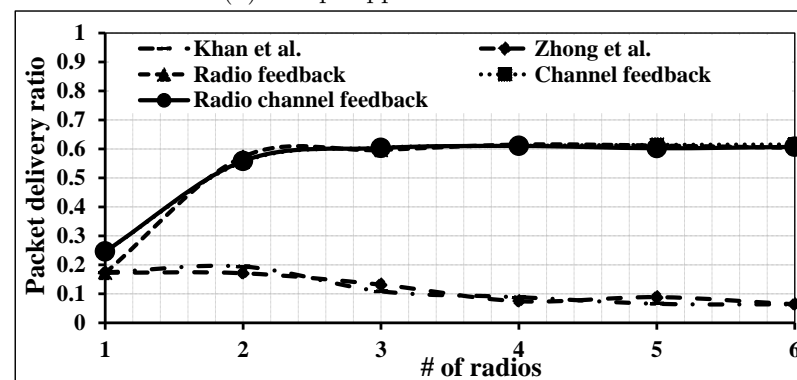

(f) 32Mbps application data rate

Figure 5.5: Application layer packet delivery ratio with varying number of radios for various application data rates

Fig. 5.4 compares the average packet drop ratio of our proposed approaches against that of the existing approaches. As illustrated in fig. 5.4, the feedback-based approach achieves significantly lower packet drop ratios than all the existing ones. The feedback-based approach is also able to reduce the packet drop ratio significantly at lower data rates (1-8 Mbps) with the exploitation of multiple radios. However, at higher application data rates (16 and 32 Mbps), most of the packets get dropped resulting in high drop ratios. This explains why the network throughput at higher data rate does not improve even after the introduction of multiple data transmission radios.

Fig. 5.5 shows the application layer packet delivery ratio of our proposed approaches against that of the existing approaches. Due to the efficient exploitation of multiple radios, our proposed approaches obtain significantly better packet delivery ratio than that achieved with the existing approaches.

Table 5.1, 5.2, and 5.3 summarize average performance improvement using feedback-based approaches in comparison to the approaches proposed by Khan et al., [1] and Zhong et al. [2]. The tables show that the proposed approach outperforms the existing approaches in terms of all the performance metrics except end-to-end delay. In terms of total network throughput, the proposed approach obtains an average of 51% improvement over the two existing approaches. Moreover, the proposed approach decreases packet drop ratio on an average 35% and increases application layer packet delivery ratio on an average 32% compared to existing approaches. Even though, the feedback-based approach experiences the higher delay in some cases, in average, the delay is improved by 13% on an average.

5.4 Simulation Findings

Though we have performed discrete event simulations for various network topologies varying the number of secondary users from 12 to 40 with a granularity of 4, in this thesis, due to space limitation, we have presented the simulation results for only one topology with 24 secondary users. Appendix A of this thesis contains the other results. Here, our proposed approach for MRCRNs obtains similar simulation results in case of other seven network topologies as well. Based on these simulation results, we obtain the following findings:

- Over all these topologies, our proposed feedback-based approach improves total network throughput by 51% on an average against that of existing approaches.

Table 5.1: Performance improvement achieved using our proposed radio feedback-based approach compared to the approaches proposed by Khan et al., [1] and Zhong et al., [2]

| Application data rate | % increase in throughput with respect to | | % decrease in end-to-end delay with respect to | | % decrease in packet drop ratio with respect to | | % increase in application layer packet delivery ratio with respect to | |
|-----------------------|--|--------------|--|--------------|---|--------------|---|--------------|
| | Khan et al. | Zhong et al. | Khan et al. | Zhong et al. | Khan et al. | Zhong et al. | Khan et al. | Zhong et al. |
| 1Mbps | 55 | 14 | -9 | 48 | 57 | 57 | 12 | 12 |
| 2Mbps | 64 | 33 | -10 | 50 | 52 | 54 | 24 | 27 |
| 4Mbps | 66 | 44 | -16 | 45 | 40 | 41 | 52 | 52 |
| 8Mbps | 63 | 46 | -17 | 32 | 26 | 26 | 42 | 43 |
| 16Mbps | 62 | 48 | -16 | 24 | 18 | 18 | 40 | 46 |
| 32Mbps | 63 | 42 | -13 | 28 | 13 | 12 | 69 | 73 |

Table 5.2: Performance improvement achieved using our proposed channel feedback-based approach compared to the approaches proposed by Khan et al., [1] and Zhong et al., [2]

| Application data rate | % increase in throughput with respect to | | % decrease in end-to-end delay with respect to | | % decrease in packet drop ratio with respect to | | % increase in application layer packet delivery ratio with respect to | |
|-----------------------|--|--------------|--|--------------|---|--------------|---|--------------|
| | Khan et al. | Zhong et al. | Khan et al. | Zhong et al. | Khan et al. | Zhong et al. | Khan et al. | Zhong et al. |
| 1Mbps | 55 | 15 | -8 | 49 | 58 | 58 | 12 | 41 |
| 2Mbps | 63 | 31 | -15 | 48 | 51 | 51 | 27 | 55 |
| 4Mbps | 66 | 44 | -11 | 42 | 40 | 38 | 52 | 52 |
| 8Mbps | 64 | 49 | -16 | 31 | 30 | 30 | 44 | 48 |
| 16Mbps | 68 | 55 | -13 | 25 | 21 | 20 | 45 | 47 |
| 32Mbps | 64 | 44 | -16 | 23 | 15 | 15 | 73 | 68 |

- Over all these topologies, our proposed feedback-based approach decreases packet drop ratio by 35% on an average against that of existing approaches.
- Among three variants of our proposed feedback-based approach, radio channel feedback approach marginally (3%) performs better over the other variants.

Table 5.3: Performance improvement achieved using our proposed radio channel feedback-based approach compared to the approaches proposed by Khan et al., [1] and Zhong et al., [2]

| Application data rate | % increase in throughput with respect to | | % decrease in end-to-end delay with respect to | | % decrease in packet drop ratio with respect to | | % increase in application layer packet delivery ratio with respect to | |
|-----------------------|--|--------------|--|--------------|---|--------------|---|--------------|
| | Khan et al. | Zhong et al. | Khan et al. | Zhong et al. | Khan et al. | Zhong et al. | Khan et al. | Zhong et al. |
| 1Mbps | 55 | 15 | -18 | 49 | 58 | 58 | 42 | 42 |
| 2Mbps | 63 | 31 | -15 | 49 | 51 | 51 | 58 | 58 |
| 4Mbps | 66 | 44 | -17 | 42 | 40 | 41 | 57 | 57 |
| 8Mbps | 63 | 49 | -17 | 31 | 29 | 30 | 49 | 50 |
| 16Mbps | 68 | 55 | -14 | 27 | 21 | 20 | 53 | 52 |
| 32Mbps | 64 | 43 | -13 | 23 | 15 | 15 | 73 | 73 |

- For MRNCRNs, our proposed feedback-based approach increases throughput with an increase in the number of radios for low to medium (1 – 8Mbps) data rates. For high data rates (16 – 32 Mbps), multiple radio introduction could not make significant impact on throughput and throughput usually degrades with an increase in the number of radios.
- For MRNCRNs, our proposed feedback-based approach is able to make average end-to-end delay almost constant with an increase in the number of radios for low to medium (1 – 8Mbps) data rates. For high data rates (16 – 32 Mbps), delay usually increases with an increase in the number of radios.
- For MRNCRNs, our proposed feedback-based approach improves average packet drop ratio with an increase in the number of radios for low to medium (1 – 16Mbps) data rates. For high data rate (32 Mbps), packet drop ratio remains constant with an increase in the number of radios.

Chapter 6

Conclusion and Future Work

Cognitive radio networks suffer noteworthy throughput degradation with the introduction of multi-radio usage. We propose a feedback-based multi-radio exploitation approach for CRNs in this thesis to overcome this throughput degradation. We implement the proposed approach in ns-3 to measure various performance metrics such as throughput, delay, packet delivery ratio, and packet drop ratio over several network settings. Simulation results reveal that our proposed approach can significantly increase total network throughput along with decreasing packet drop ratio and delay compared to other existing techniques. Furthermore, the feedback-based approach can be used to find a suitable number of radios needed to experience a delicate tradeoff between network throughput and delay for applications maintaining different data rates. In future, we plan to formulate analytical models of our proposed approach and implement the approach in real testbed.

In our study, we perform extensive simulations to validate our proposed approach. In future, we plan to validate our presented solution over CR testbed. We also plan to formulate analytical models of the solution in future. Here, our target is to model the probability of successful packet transmission and the probability of selecting PU-free channels. From these two models, we plan to formulate separate models for delay and throughput of our proposed MRN architecture. Furthermore, in this thesis, we are considering only a sender-side algorithm. Therefore, the sender-receiver mapping is fixed in nature. To assign senders and receivers dynamically, we will require a receiver-side algorithm as well. In future, we would like to augment our proposed approach with a receiver-side algorithm. Besides, multi-path communication via multiple cognitive radios would be another interesting field to study. In future, we plan to investigate the performance of MRNs exploiting multi-path communication.

Appendix A

Simulation Results for Different Network Topologies

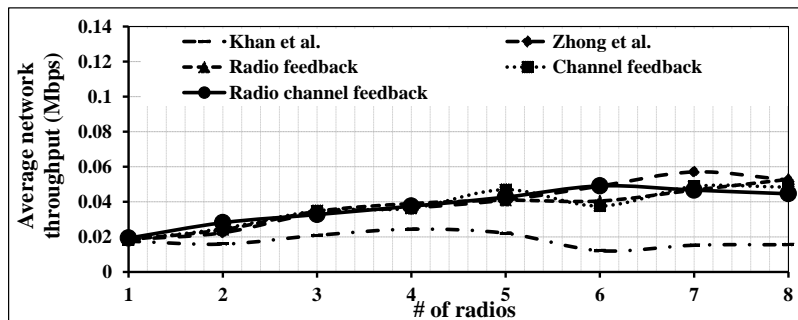

(a) 1Mbps application data rate

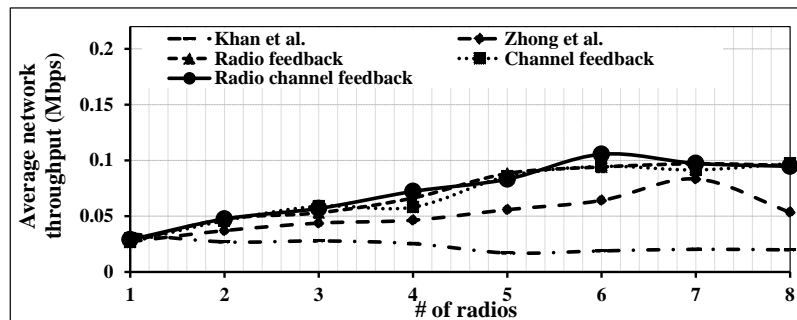

(b) 2Mbps application data rate

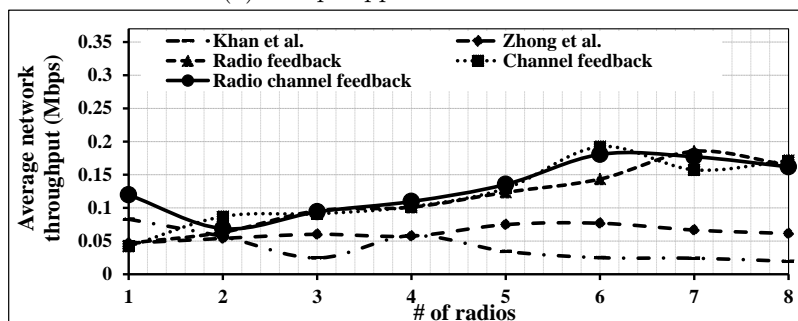

(c) 4Mbps application data rate

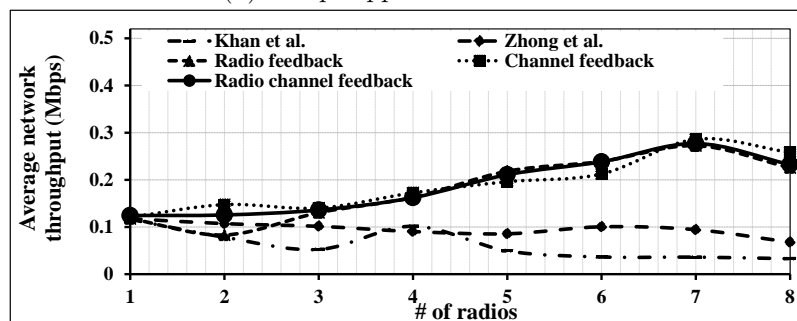

(d) 8Mbps application data rate

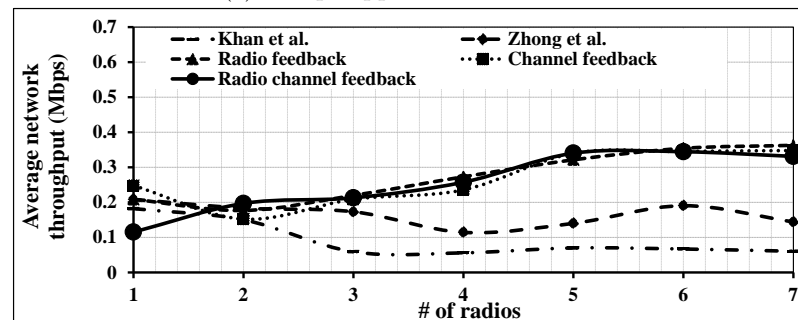

(e) 16Mbps application data rate

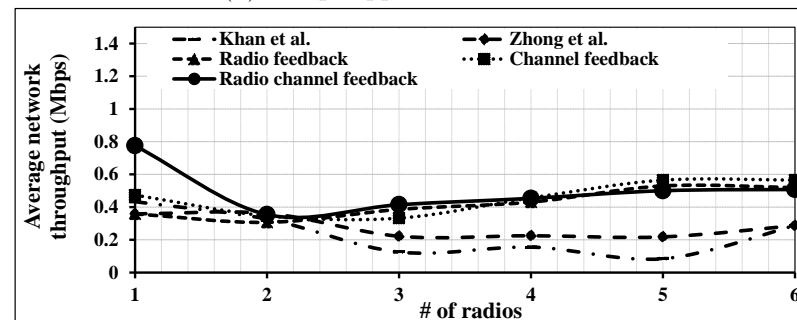

(f) 32Mbps application data rate

Figure A.1: Average network throughput with varying number of radios for various application data rates on a network topology with 12 secondary users

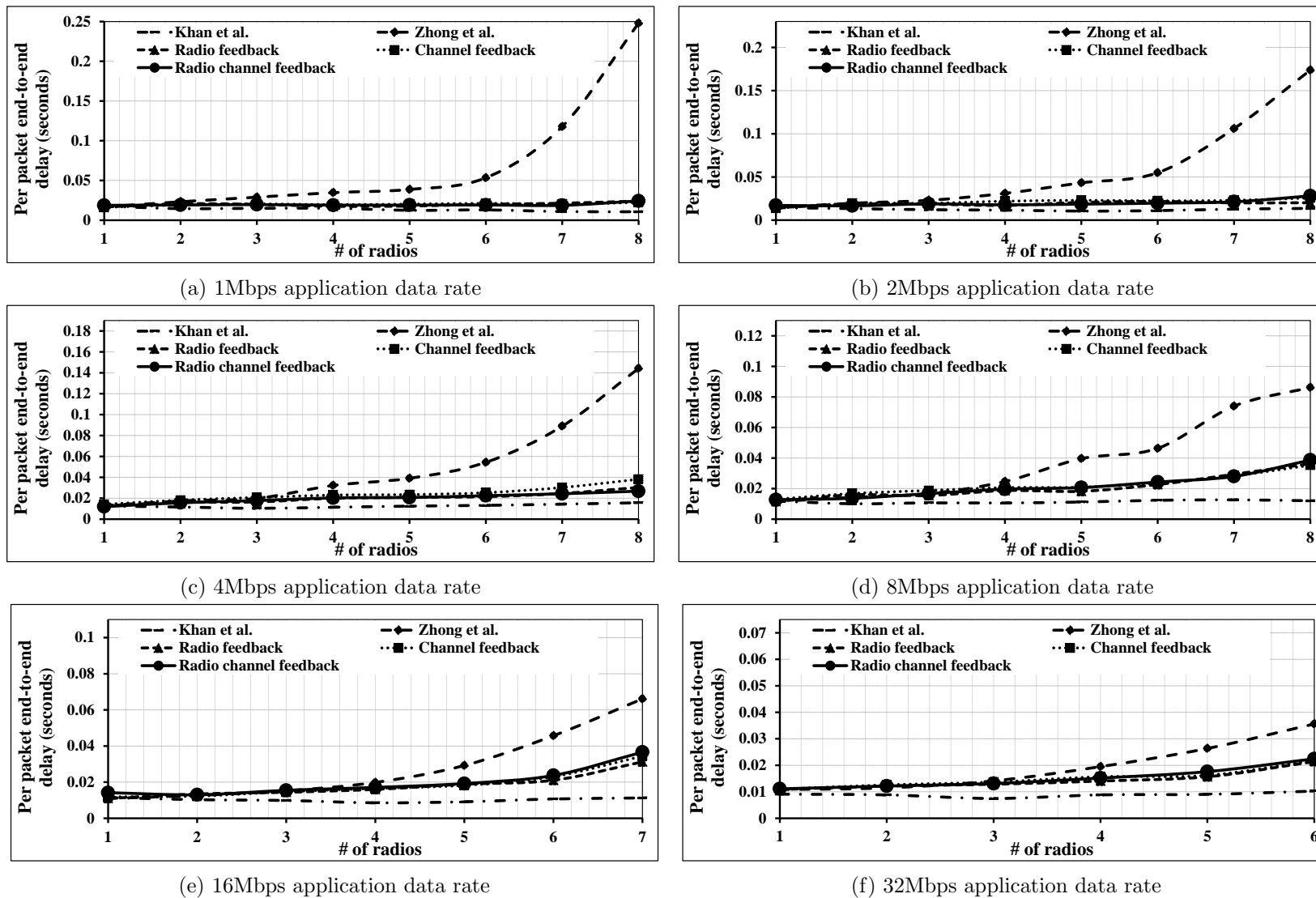
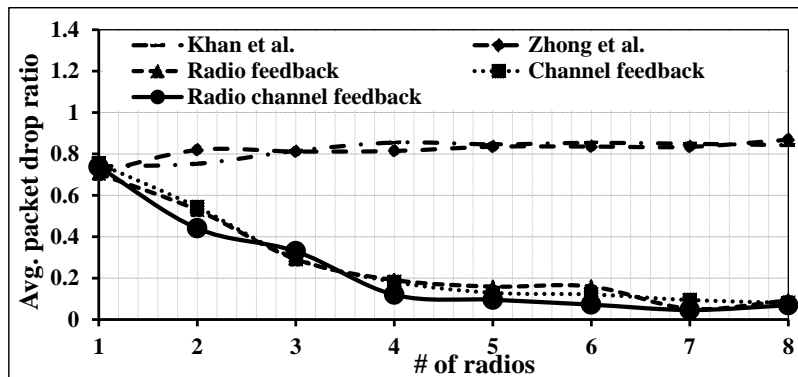
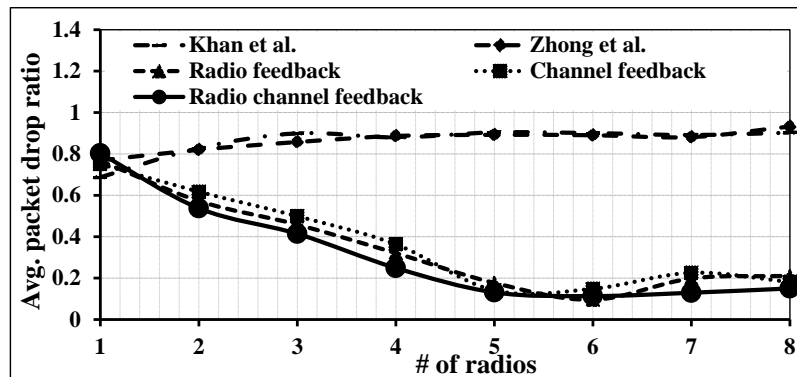

Figure A.2: Average end-to-end delay with varying number of radios for various application data rates on a network topology with 12 secondary users



(a) 1Mbps application data rate



(b) 2Mbps application data rate

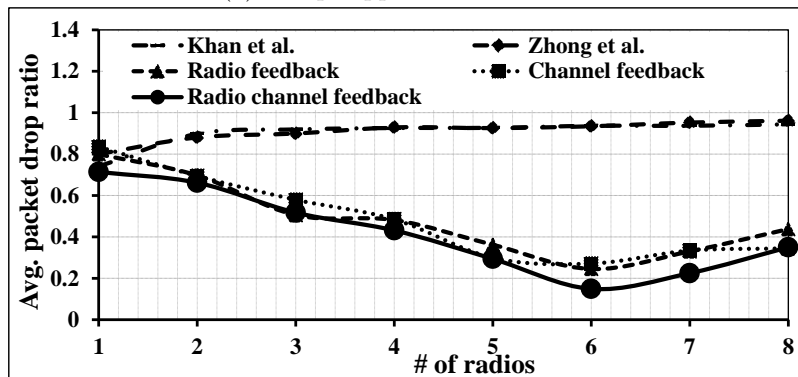

(c) 4Mbps application data rate

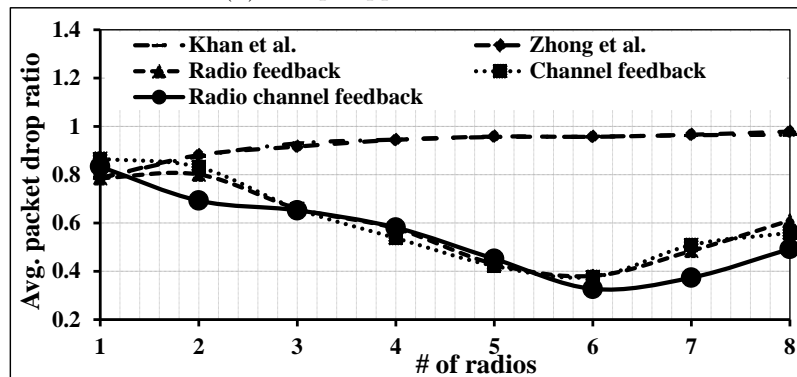

(d) 8Mbps application data rate

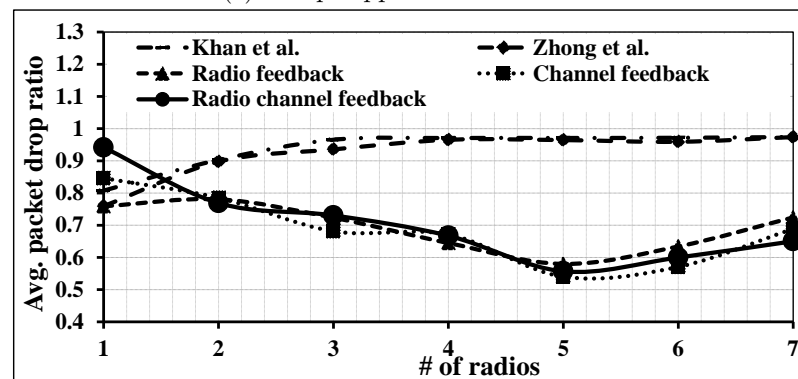

(e) 16Mbps application data rate

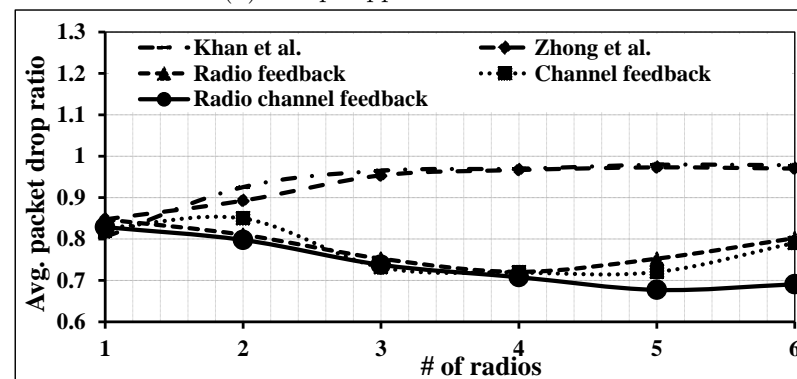

(f) 32Mbps application data rate

Figure A.3: Average packet drop ratio with varying number of radios for various application data rates on a network topology with 12 secondary users

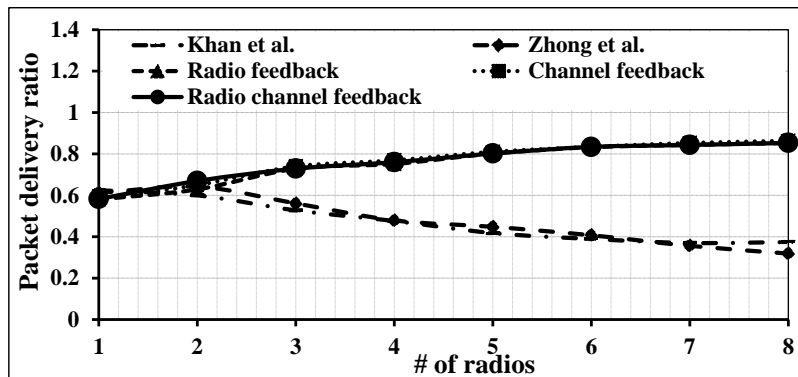

(a) 1Mbps application data rate

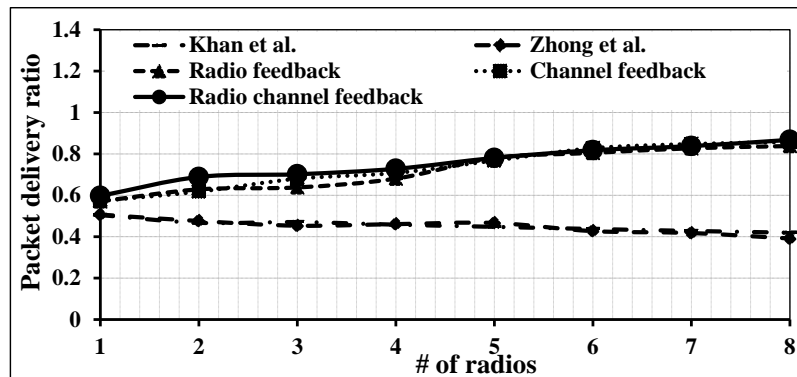

(b) 2Mbps application data rate

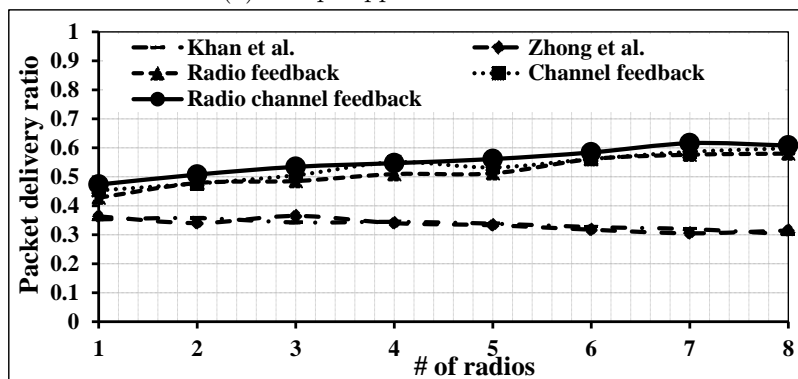

(c) 4Mbps application data rate

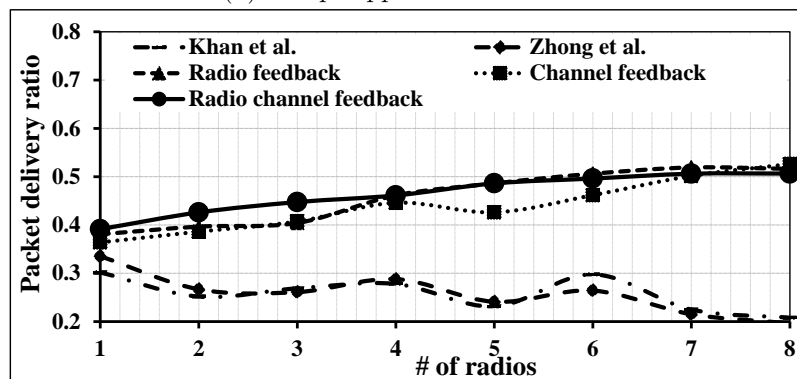

(d) 8Mbps application data rate

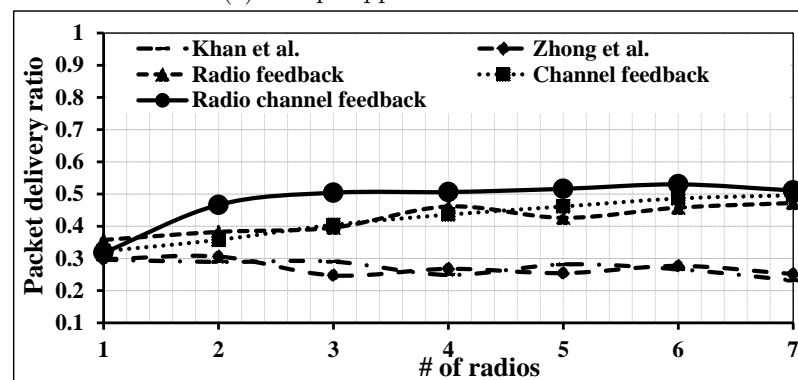

(e) 16Mbps application data rate

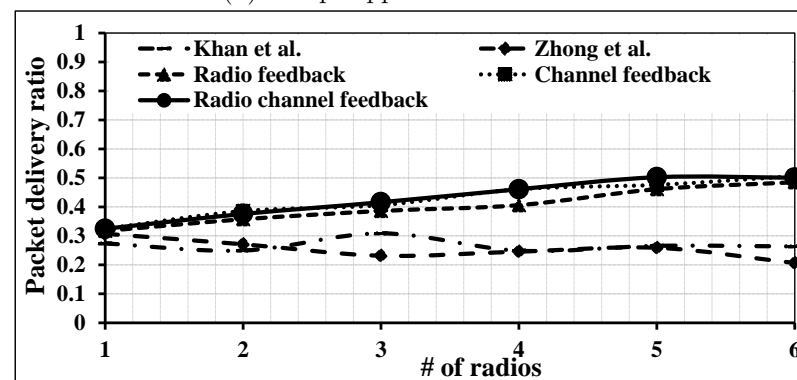

(f) 32Mbps application data rate

Figure A.4: Application layer packet delivery ratio with varying number of radios for various application data rates on a network topology with 12 secondary users

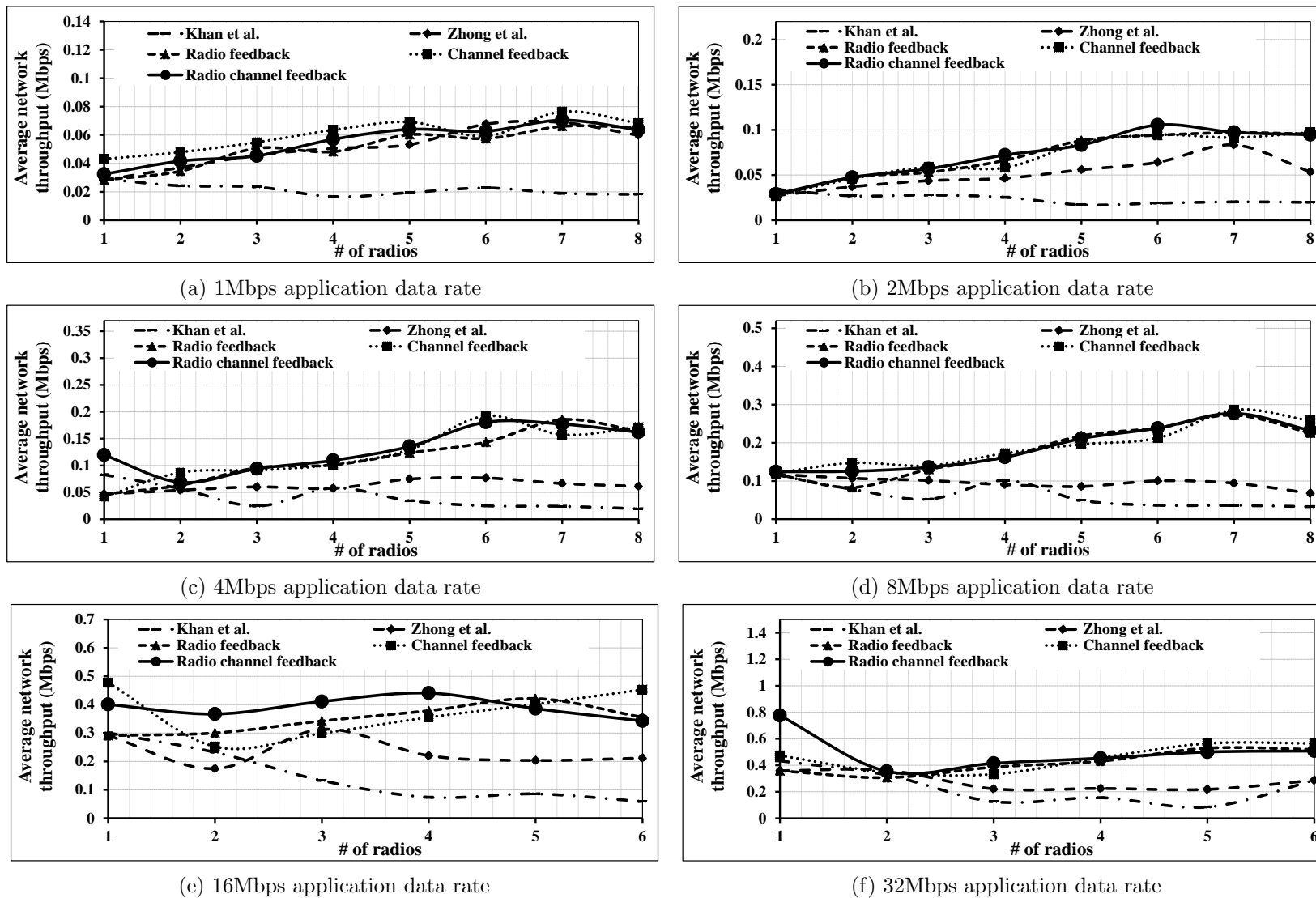

Figure A.5: Average network throughput with varying number of radios for various application data rates on a network topology with 16 secondary users

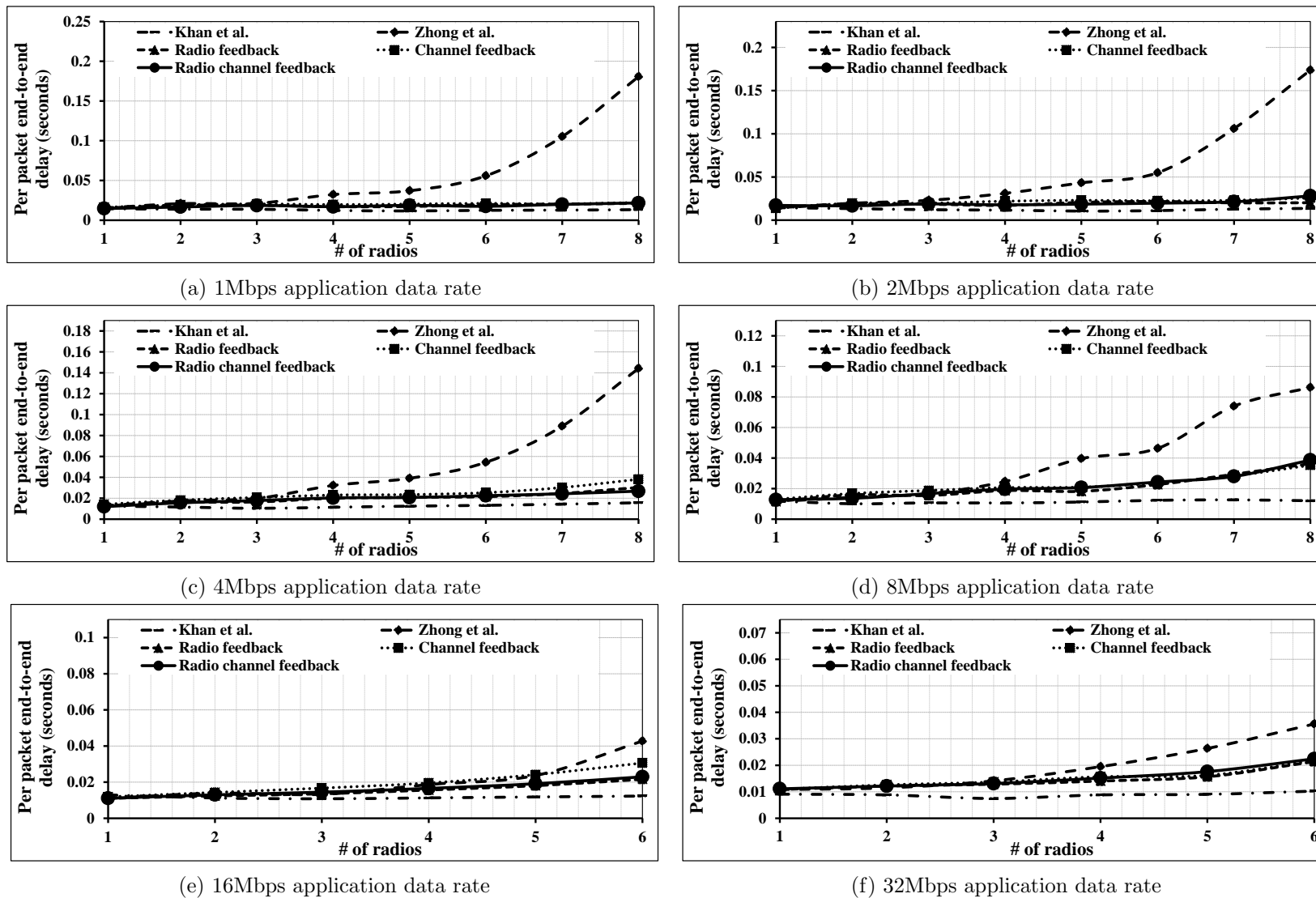
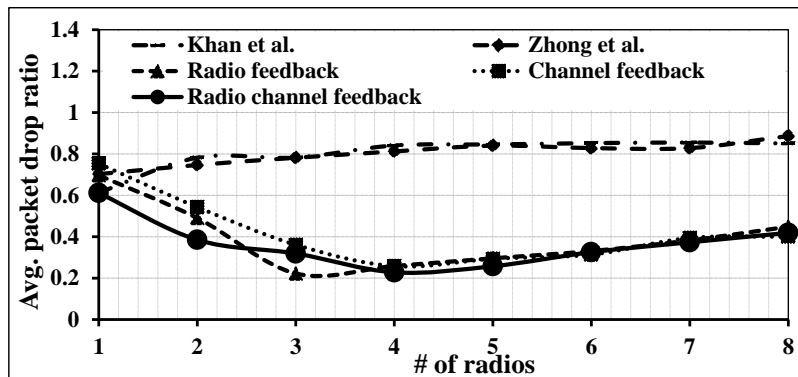
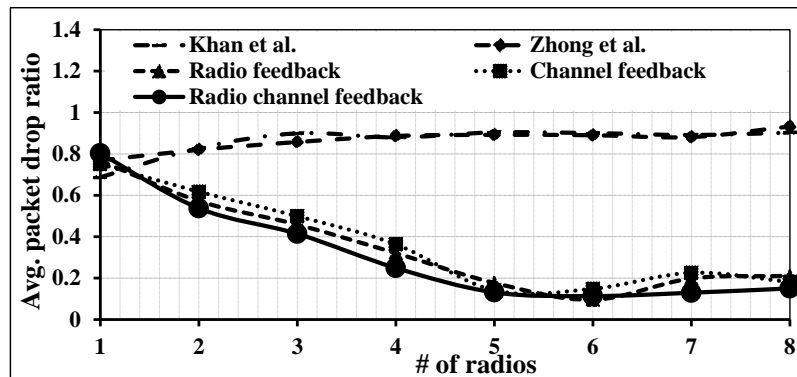

Figure A.6: Average end-to-end delay with varying number of radios for various application data rates on a network topology with 16 secondary users



(a) 1Mbps application data rate



(b) 2Mbps application data rate

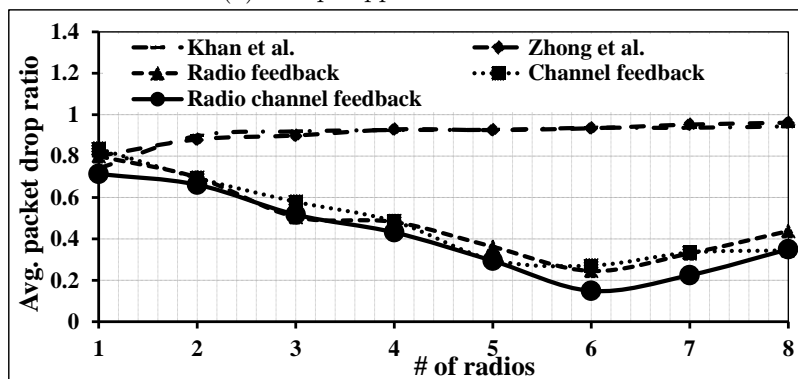

(c) 4Mbps application data rate

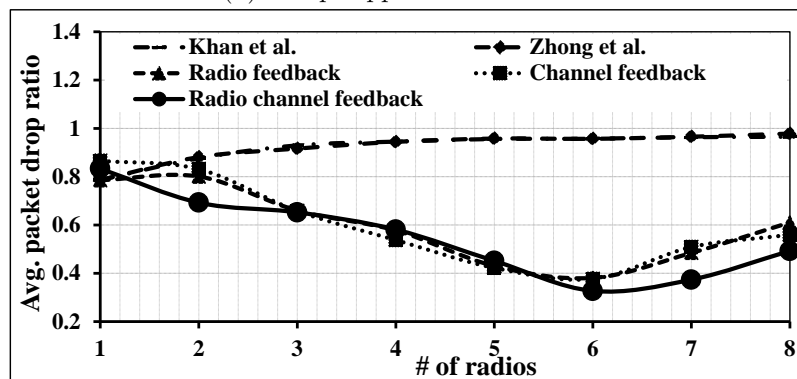

(d) 8Mbps application data rate

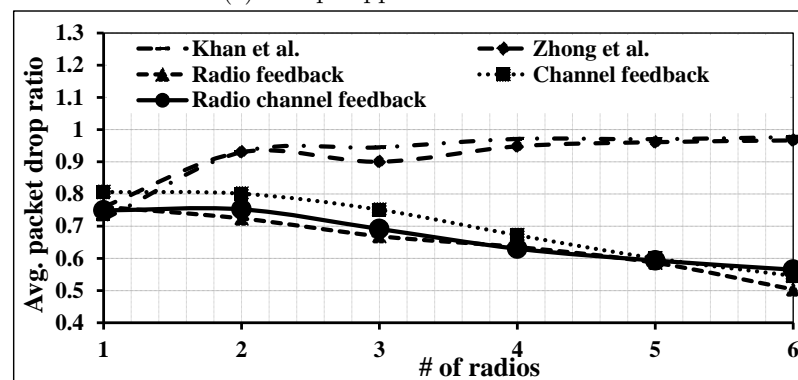

(e) 16Mbps application data rate

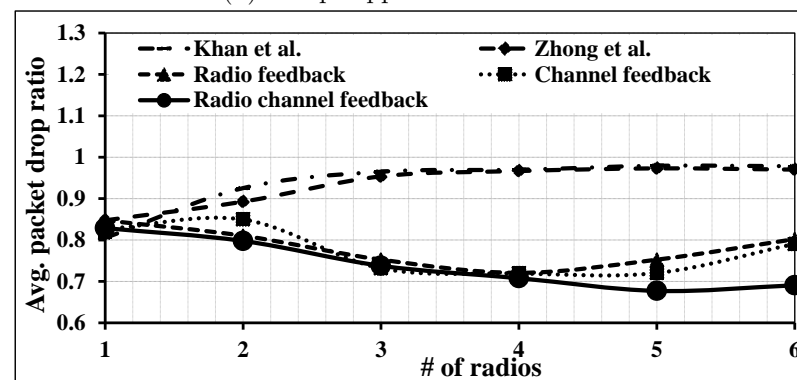

(f) 32Mbps application data rate

Figure A.7: Average packet drop ratio with varying number of radios for various application data rates on a network topology with 16 secondary users

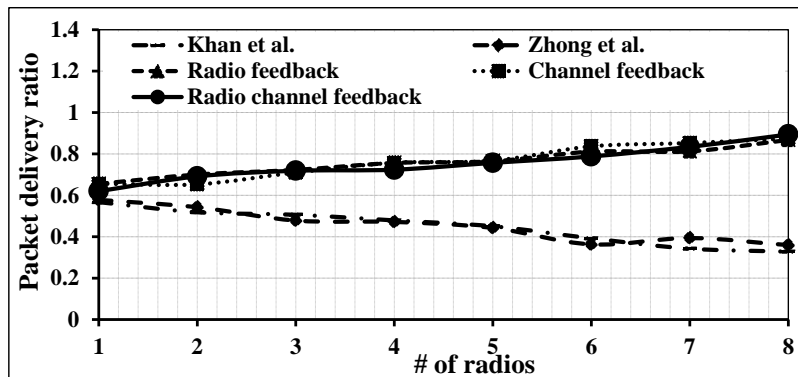

(a) 1Mbps application data rate

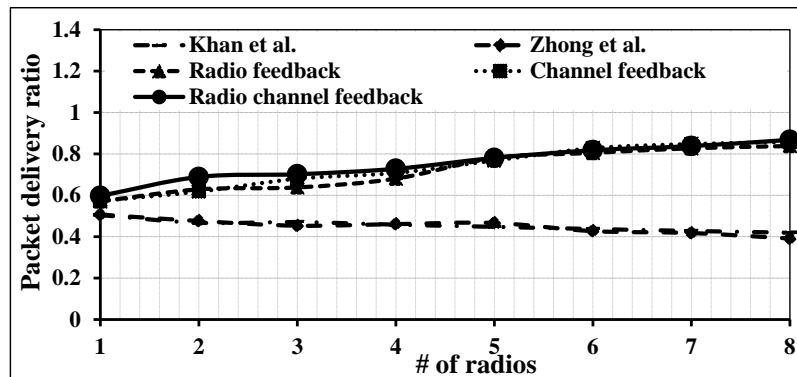

(b) 2Mbps application data rate

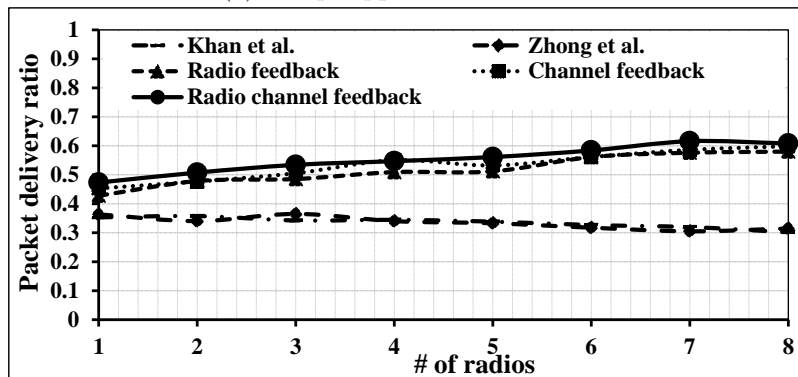

(c) 4Mbps application data rate

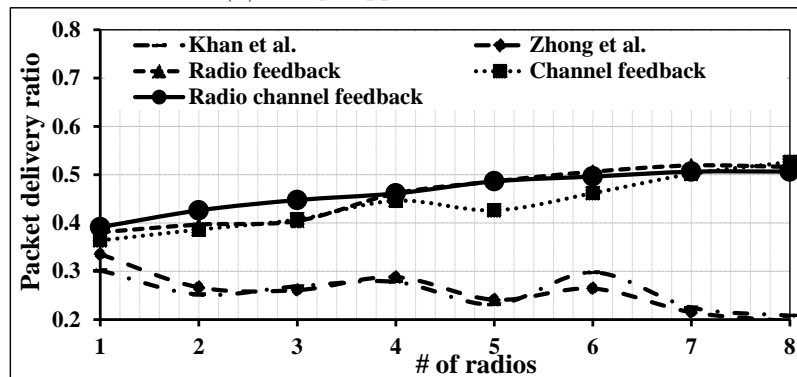

(d) 8Mbps application data rate

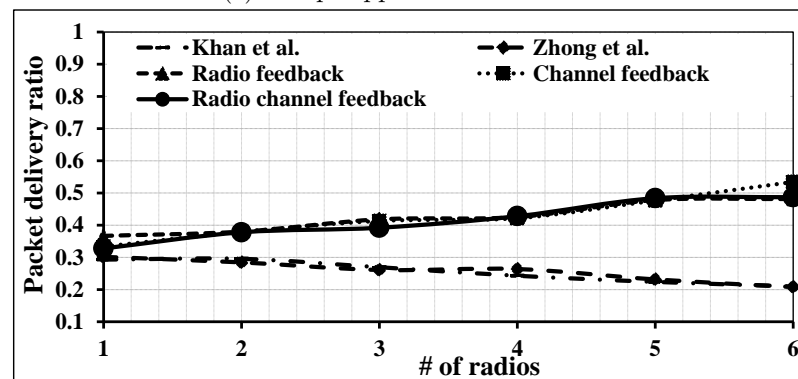

(e) 16Mbps application data rate

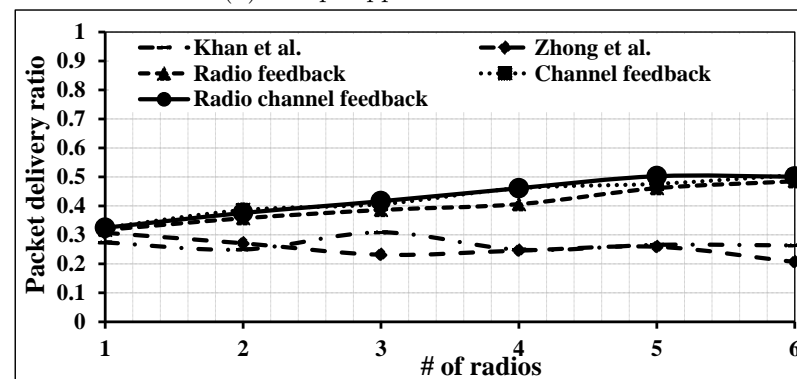

(f) 32Mbps application data rate

Figure A.8: Application layer packet delivery ratio with varying number of radios for various application data rates on a network topology with 16 secondary users

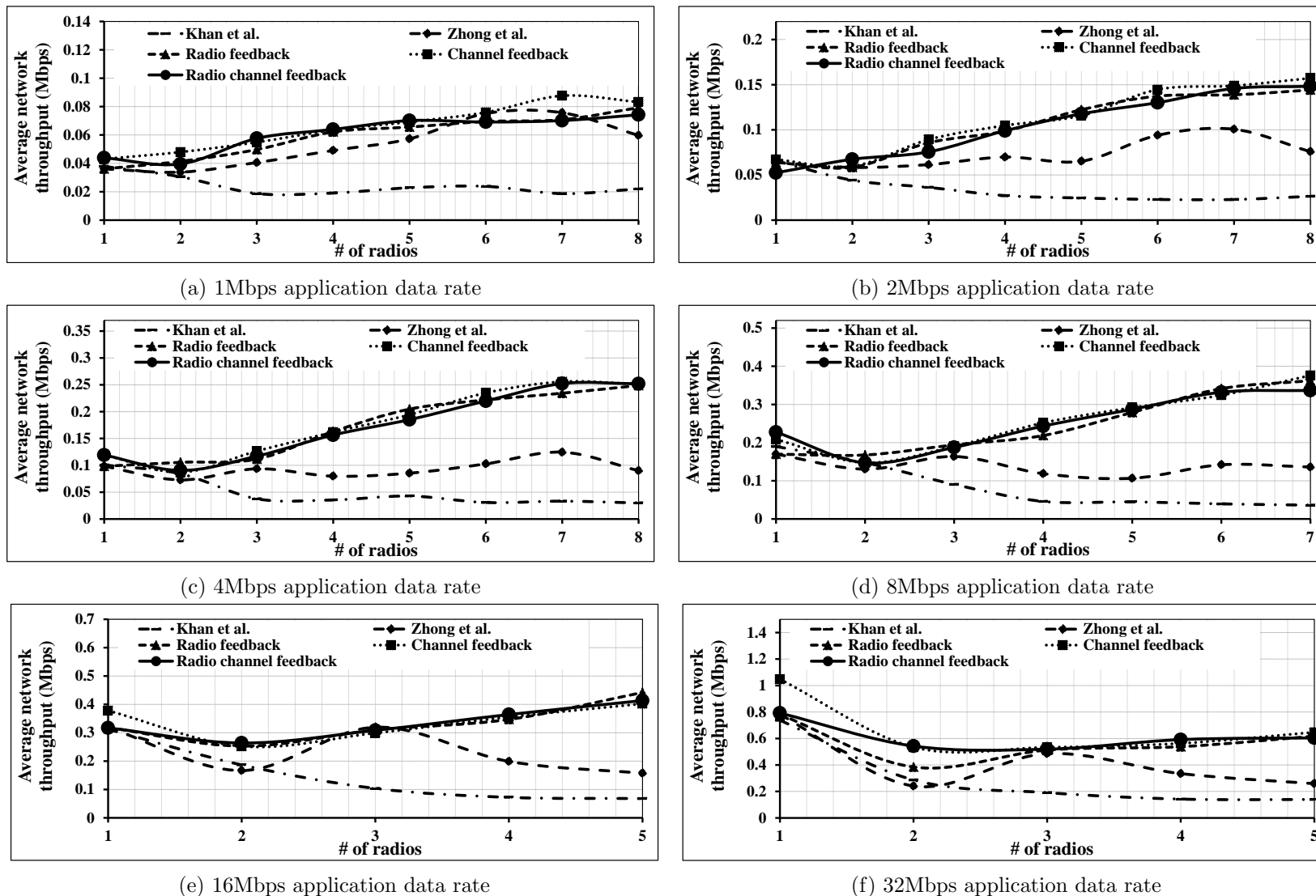

Figure A.9: Average network throughput with varying number of radios for various application data rates on a network topology with 20 secondary users

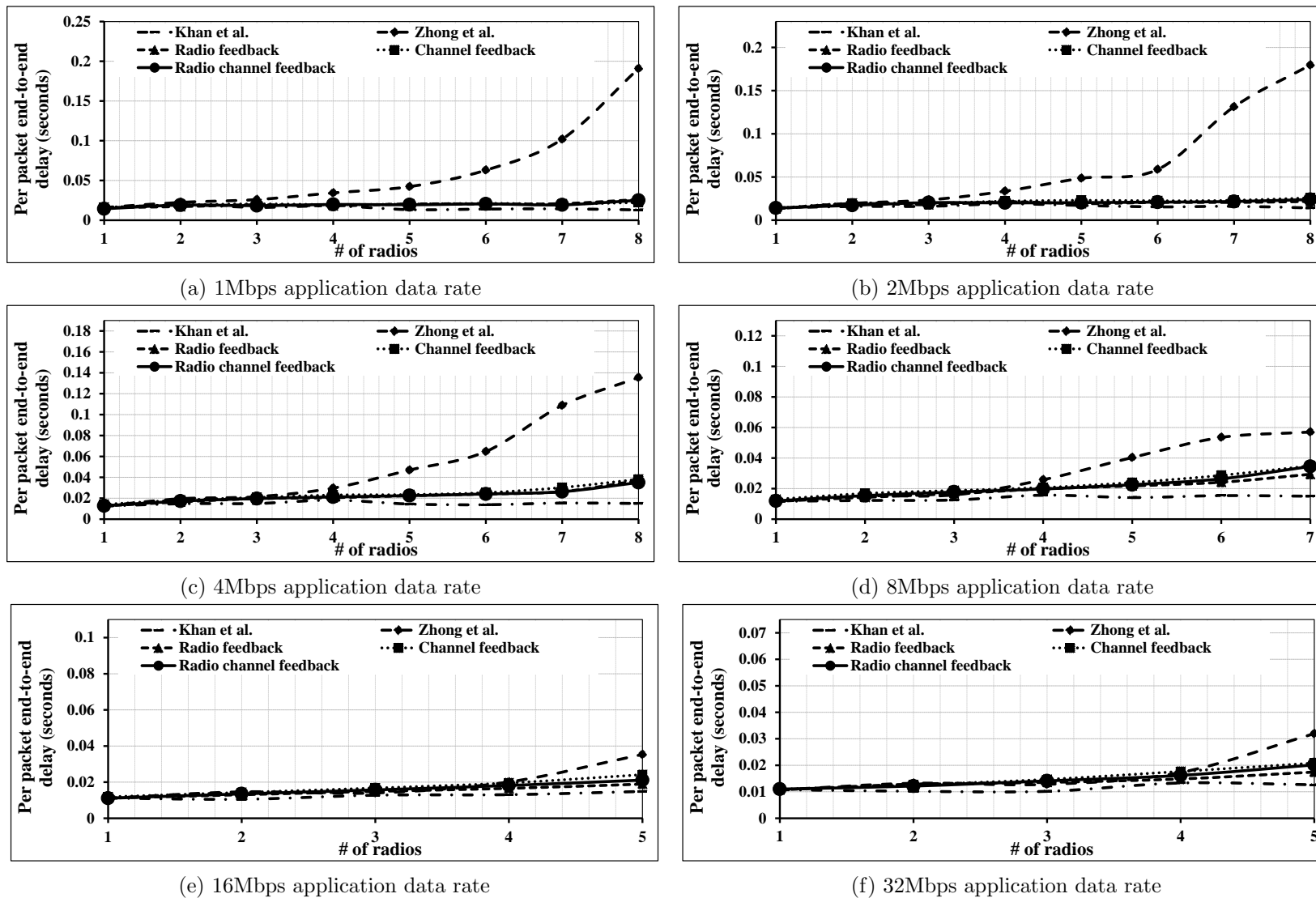
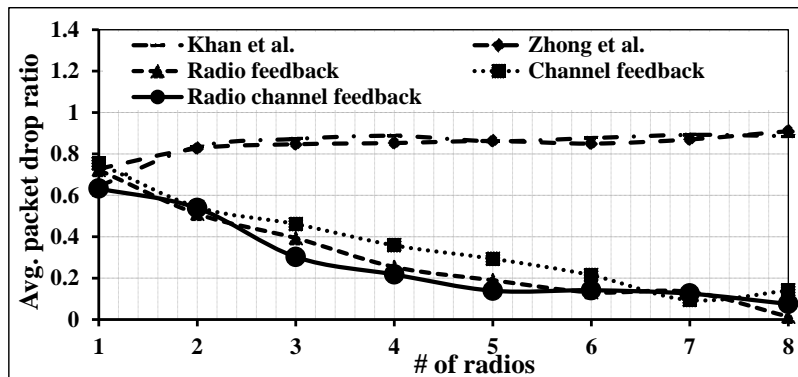
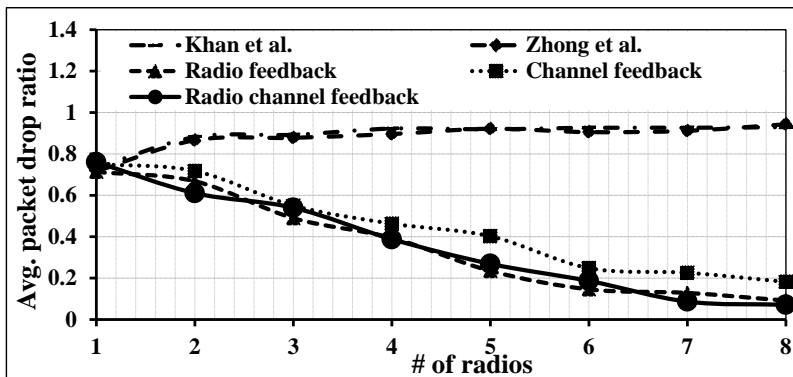

Figure A.10: Average end-to-end delay with varying number of radios for various application data rates on a network topology with 20 secondary users



(a) 1Mbps application data rate



(b) 2Mbps application data rate

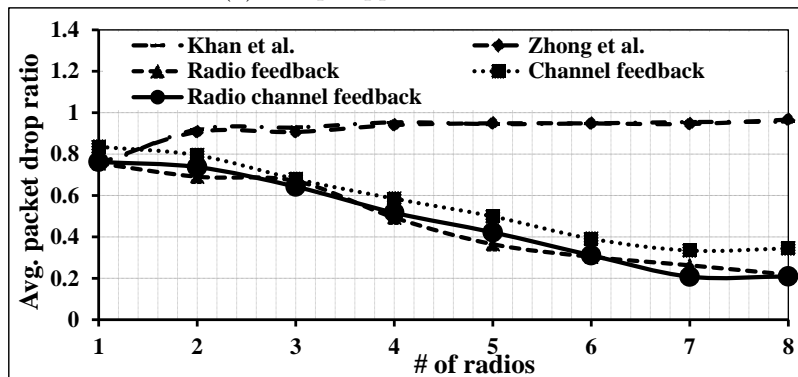

(c) 4Mbps application data rate

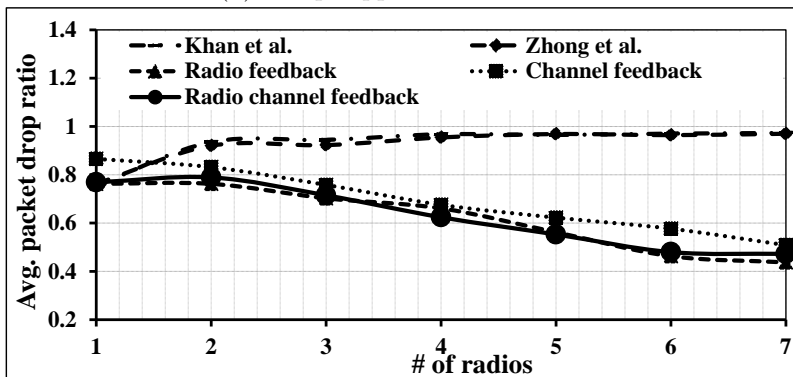

(d) 8Mbps application data rate

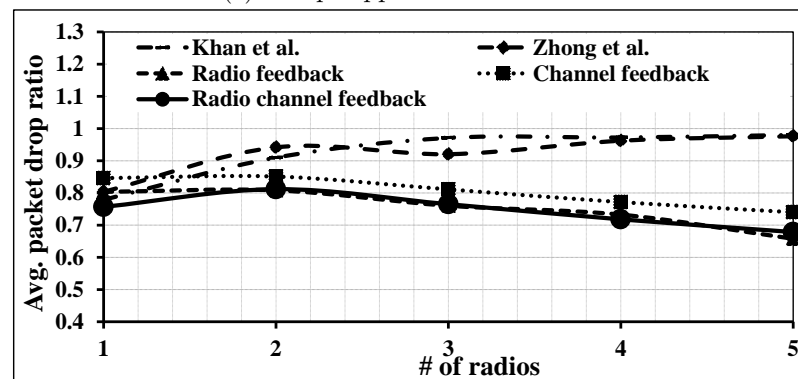

(e) 16Mbps application data rate

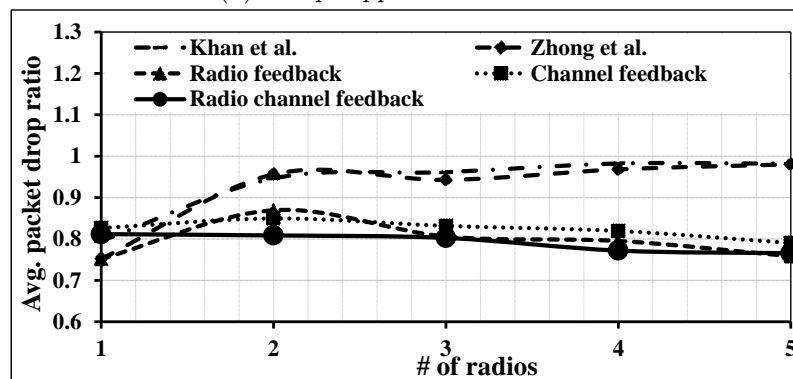

(f) 32Mbps application data rate

Figure A.11: Average packet drop ratio with varying number of radios for various application data rates on a network topology with 20 secondary users

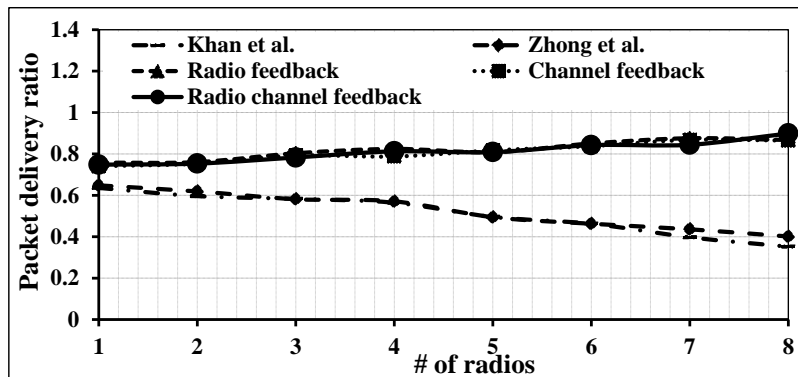

(a) 1Mbps application data rate

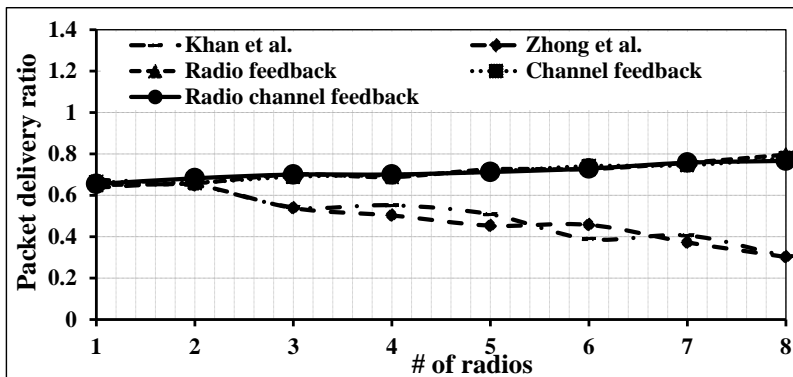

(b) 2Mbps application data rate

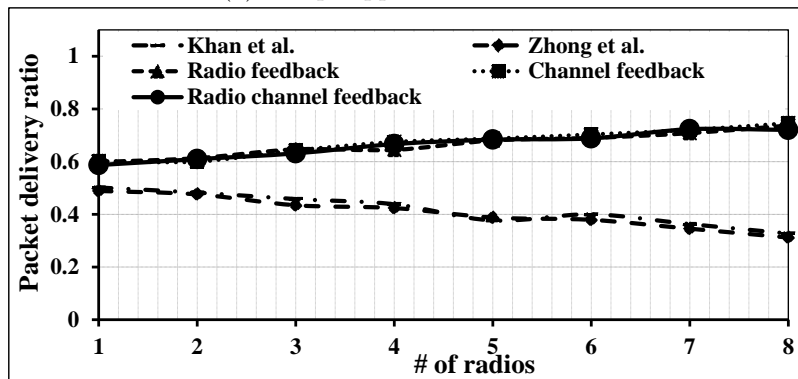

(c) 4Mbps application data rate

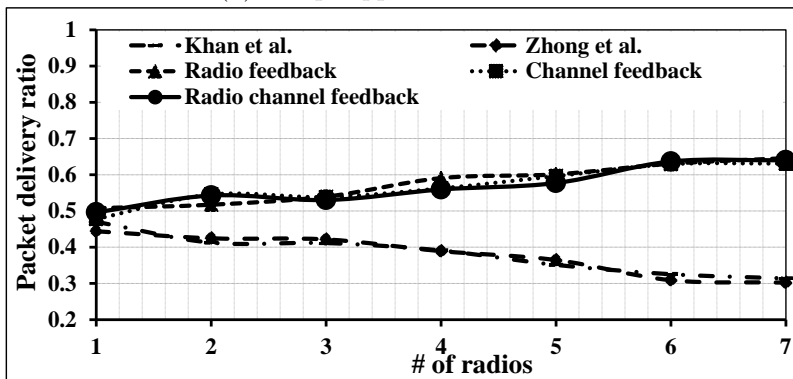

(d) 8Mbps application data rate

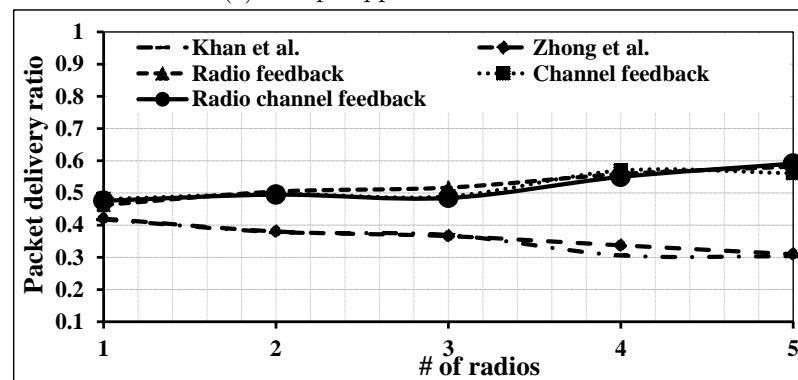

(e) 16Mbps application data rate

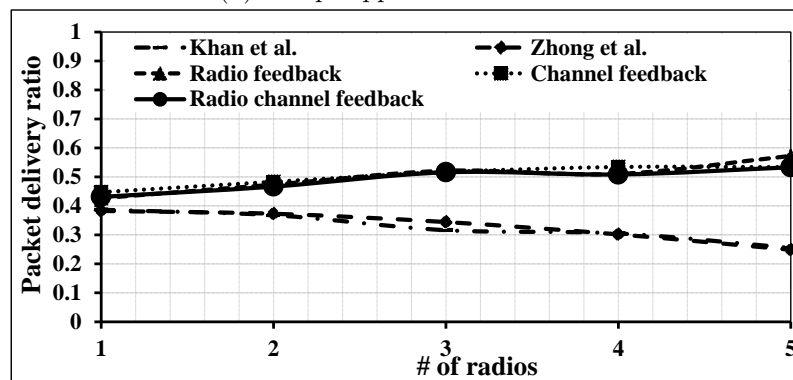

(f) 32Mbps application data rate

Figure A.12: Application layer packet delivery ratio with varying number of radios for various application data rates on a network topology with 20 secondary users

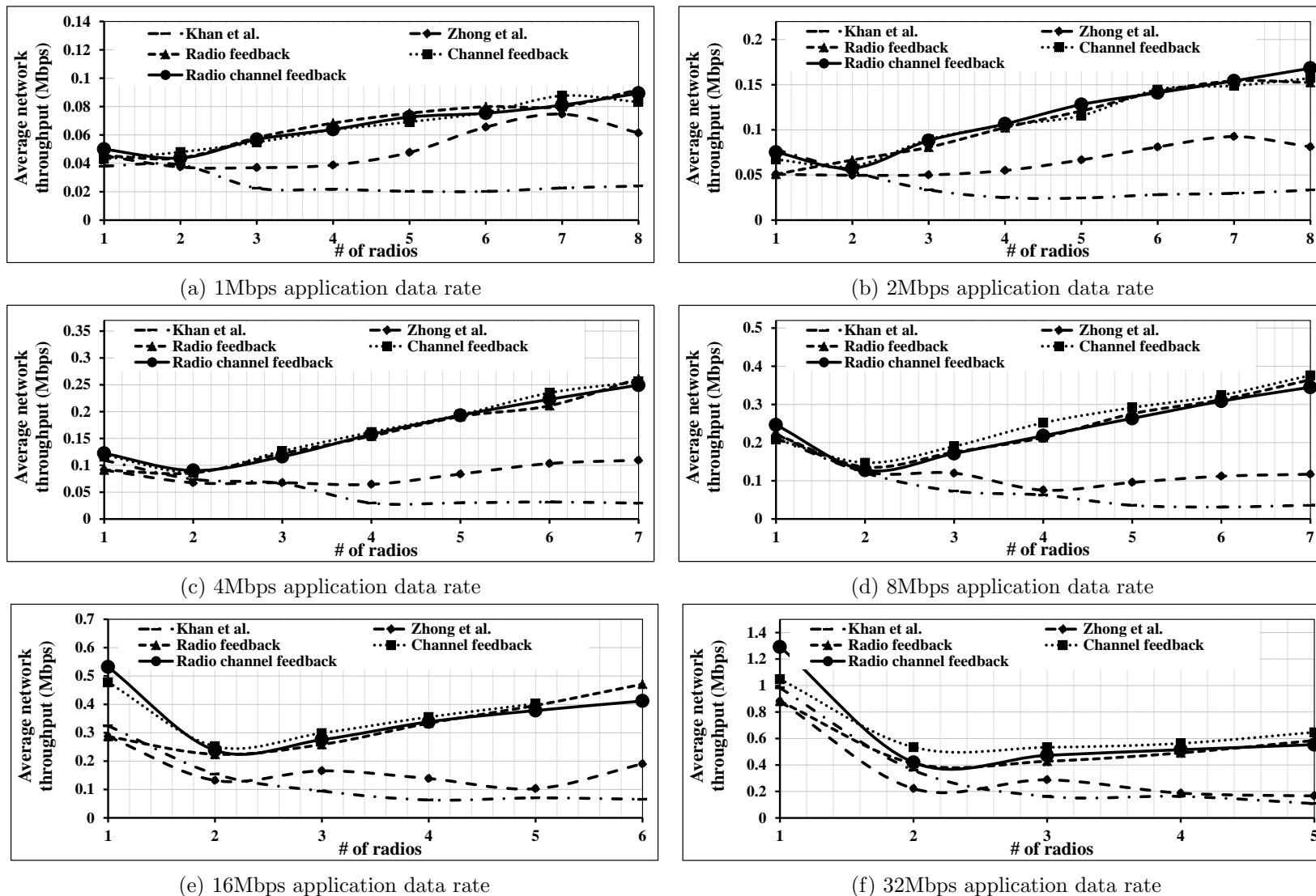

Figure A.13: Average network throughput with varying number of radios for various application data rates on a network topology with 28 secondary users

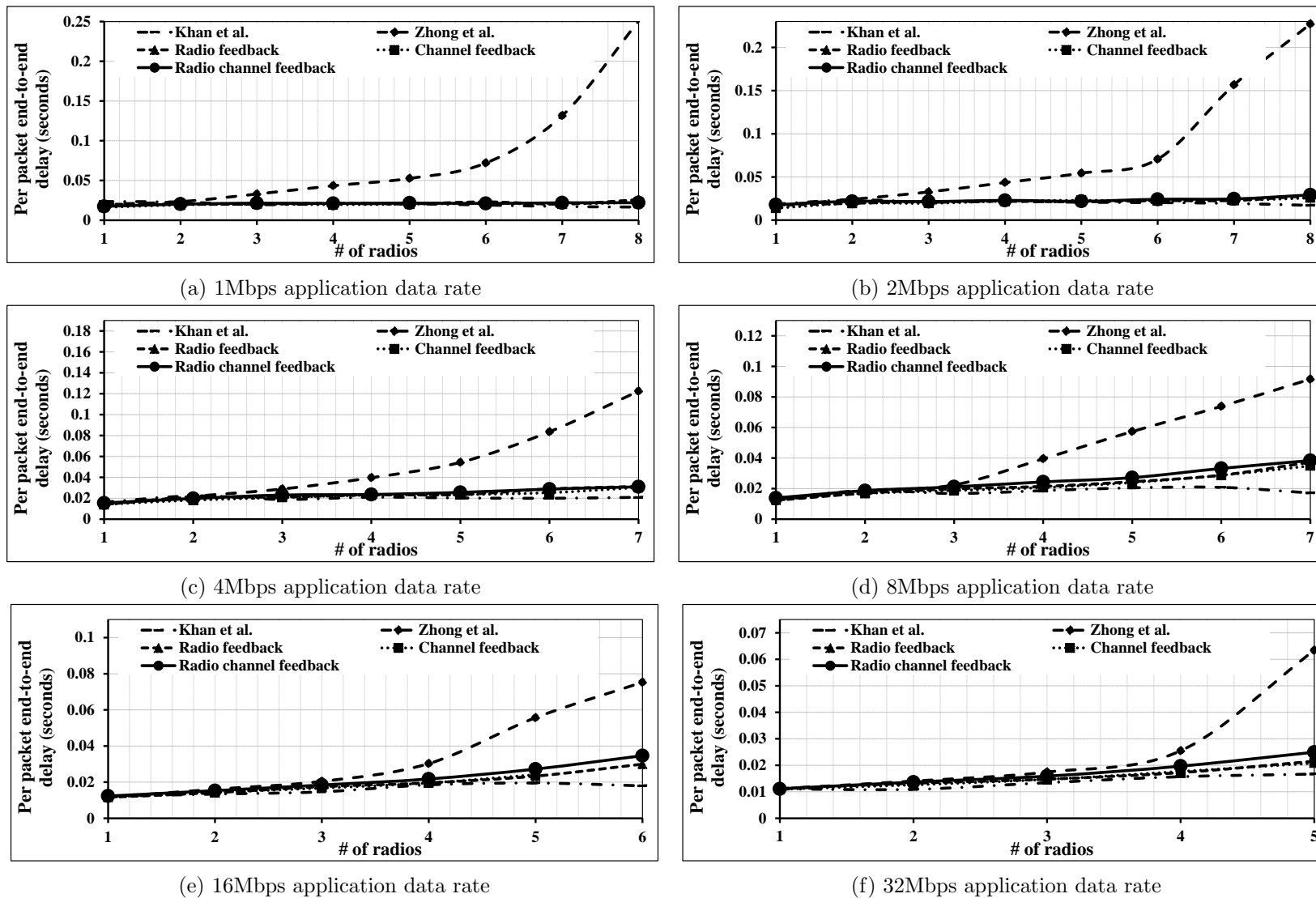
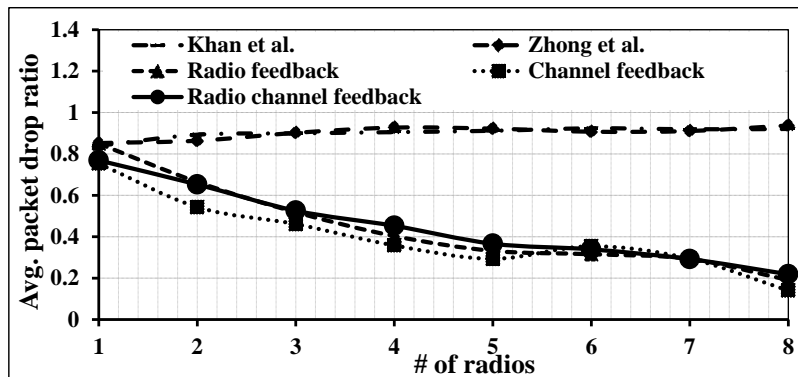
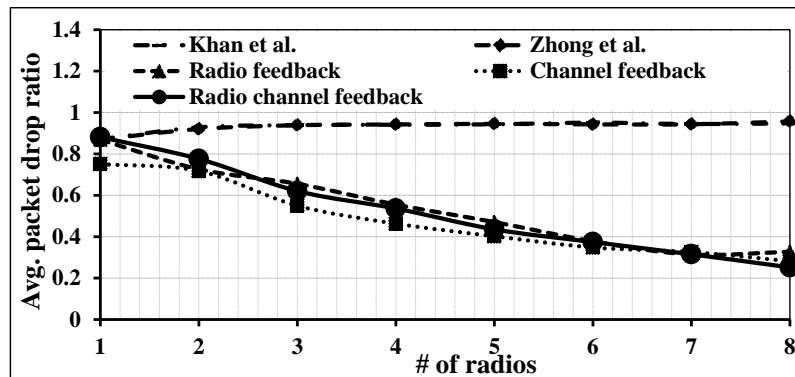

Figure A.14: Average end-to-end delay with varying number of radios for various application data rates on a network topology with 28 secondary users



(a) 1Mbps application data rate



(b) 2Mbps application data rate

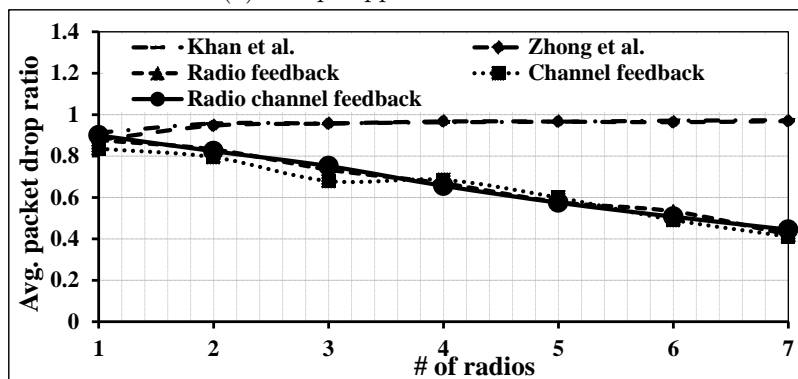

(c) 4Mbps application data rate

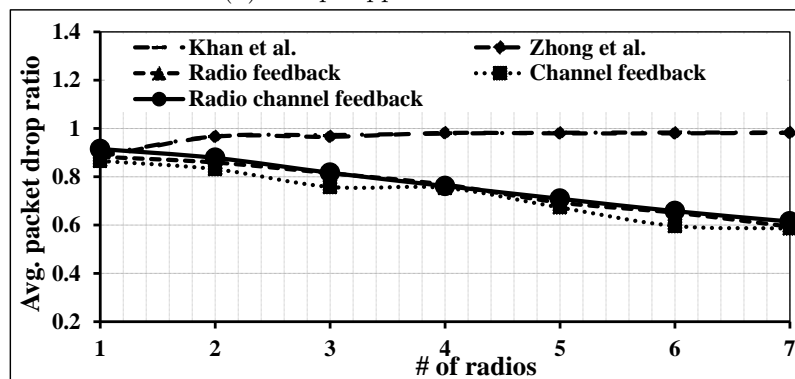

(d) 8Mbps application data rate

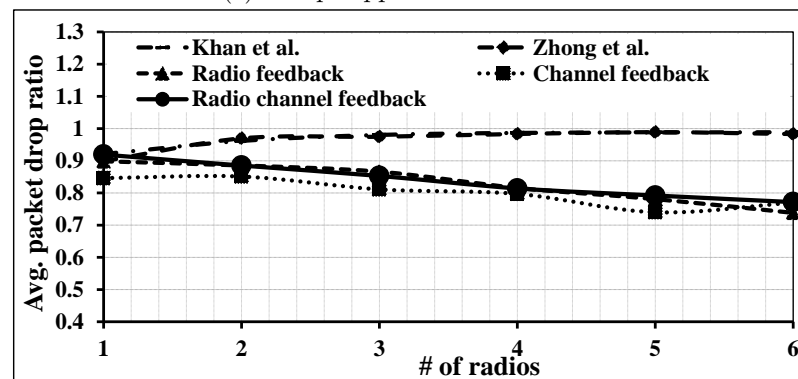

(e) 16Mbps application data rate

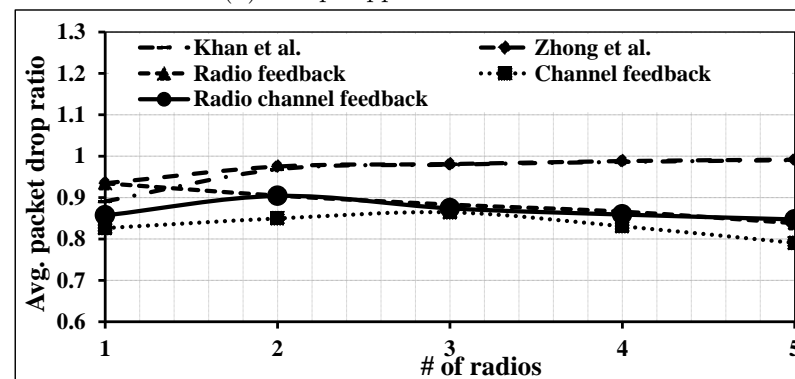

(f) 32Mbps application data rate

Figure A.15: Average packet drop ratio with varying number of radios for various application data rates on a network topology with 28 secondary users

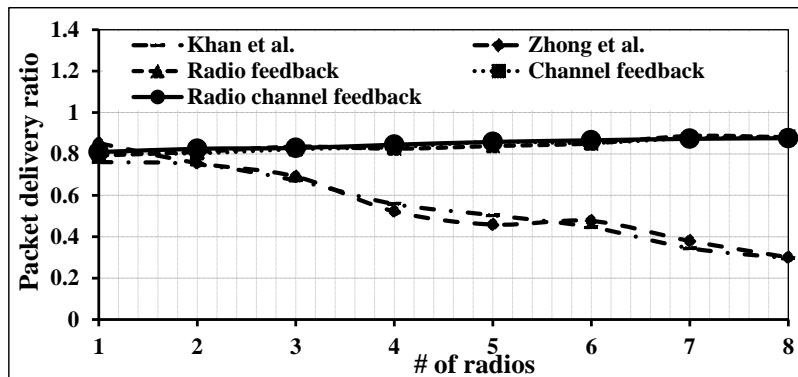

(a) 1Mbps application data rate

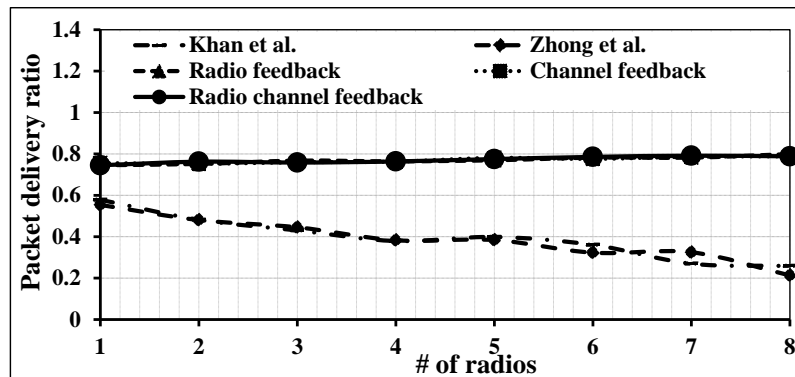

(b) 2Mbps application data rate

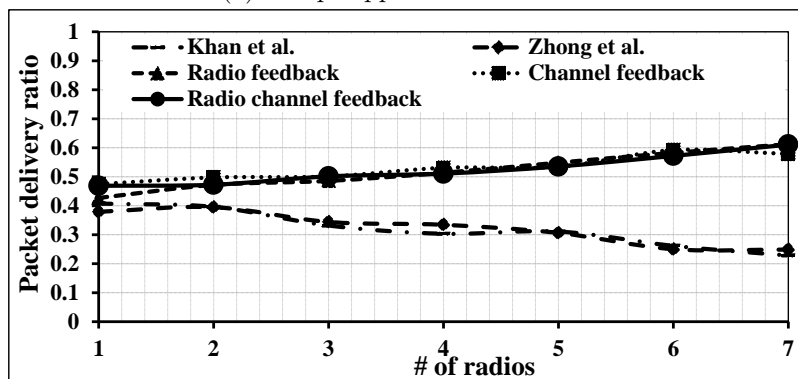

(c) 4Mbps application data rate

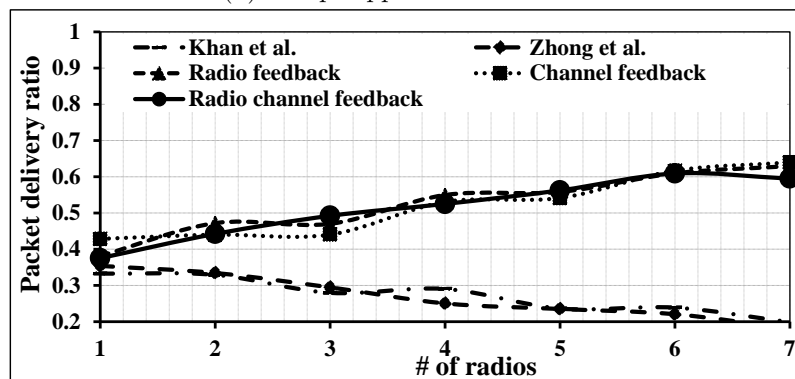

(d) 8Mbps application data rate

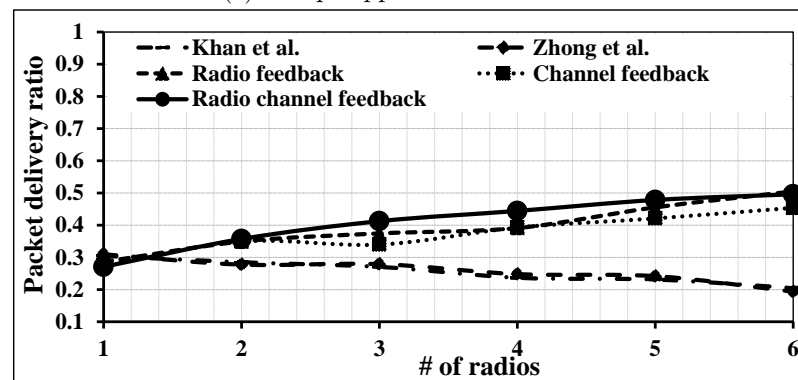

(e) 16Mbps application data rate

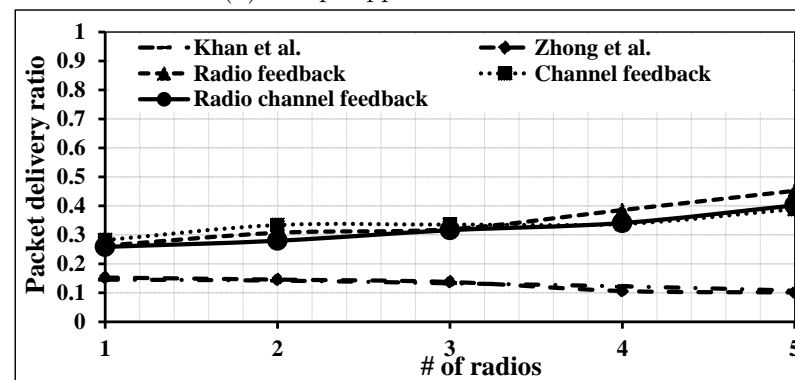

(f) 32Mbps application data rate

Figure A.16: Application layer packet delivery ratio with varying number of radios for various application data rates on a network topology with 28 secondary users

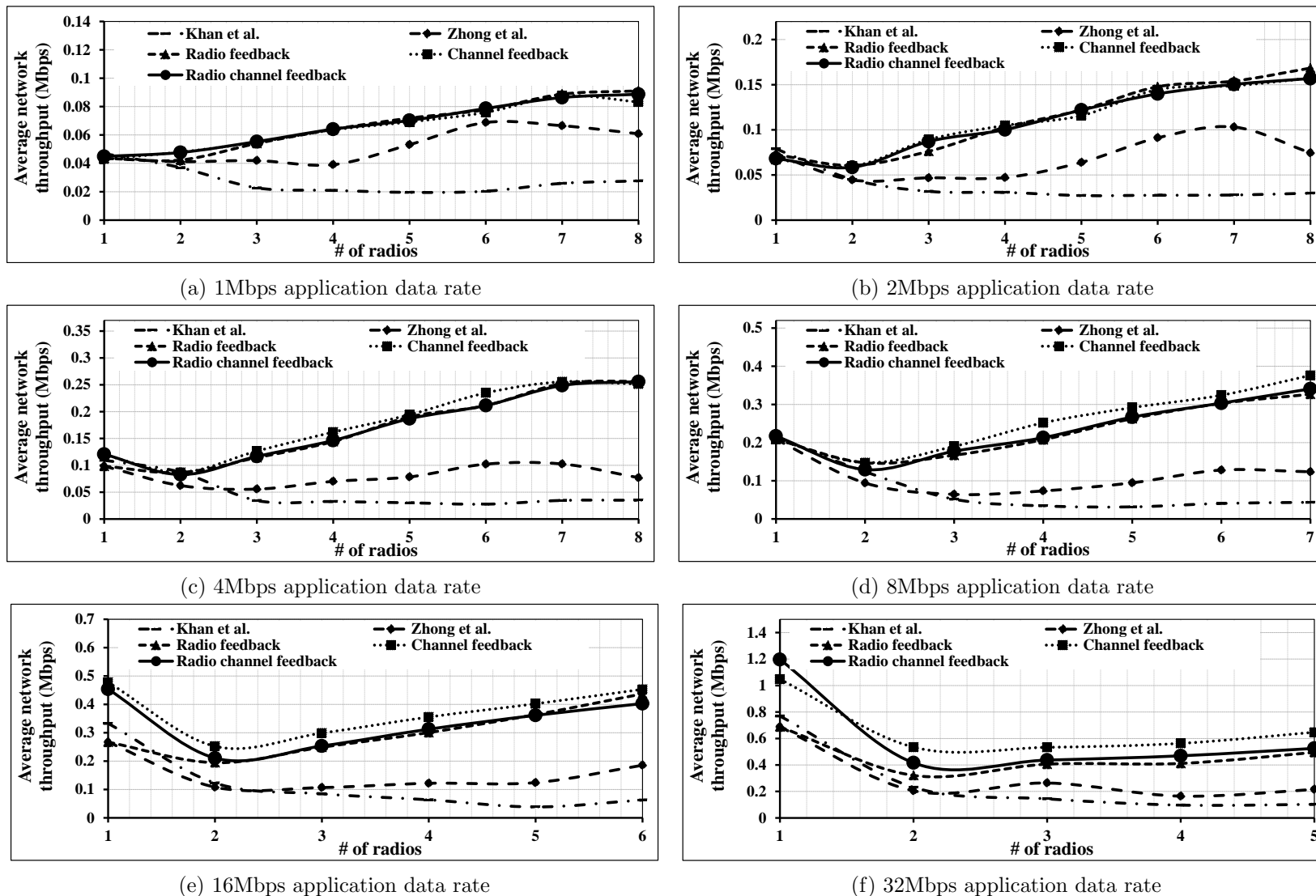

Figure A.17: Average network throughput with varying number of radios for various application data rates on a network topology with 32 secondary users

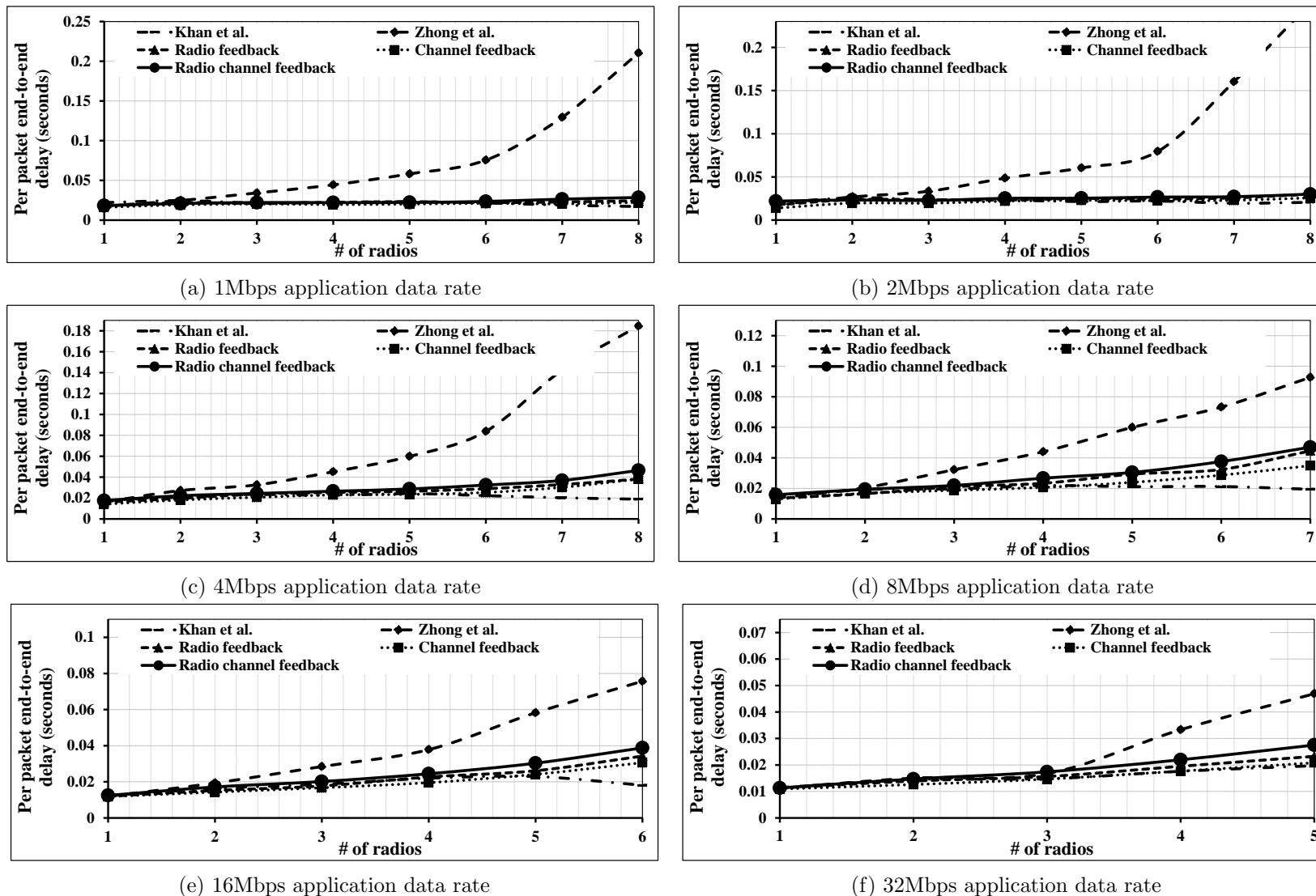
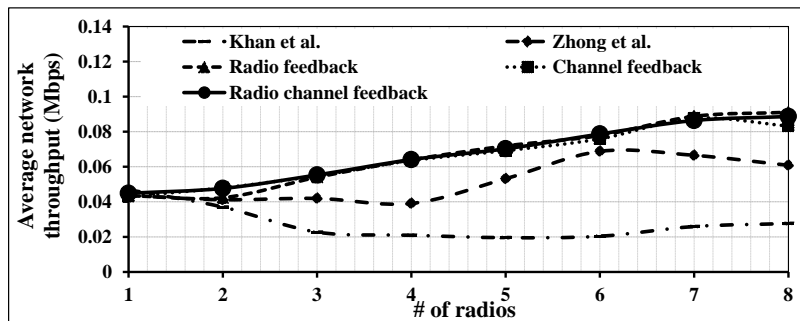
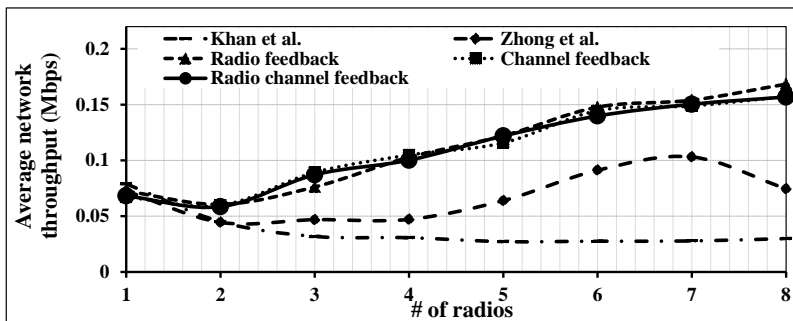

Figure A.18: Average end-to-end delay with varying number of radios for various application data rates on a network topology with 32 secondary users



(a) 1Mbps application data rate



(b) 2Mbps application data rate

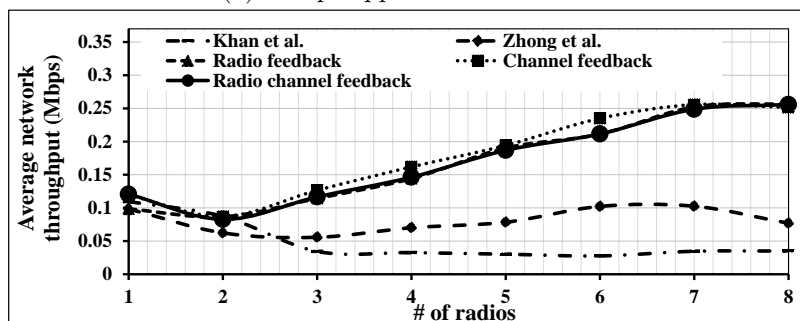

(c) 4Mbps application data rate

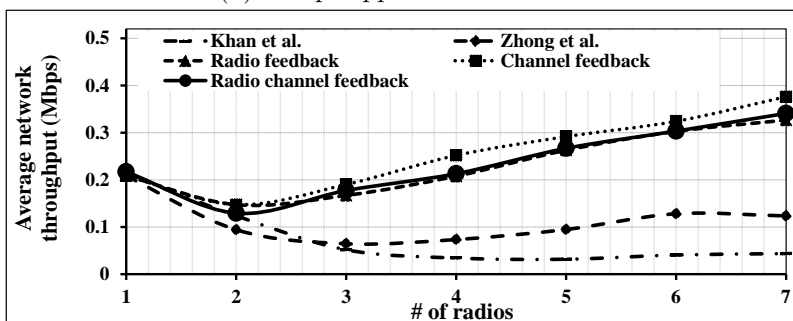

(d) 8Mbps application data rate

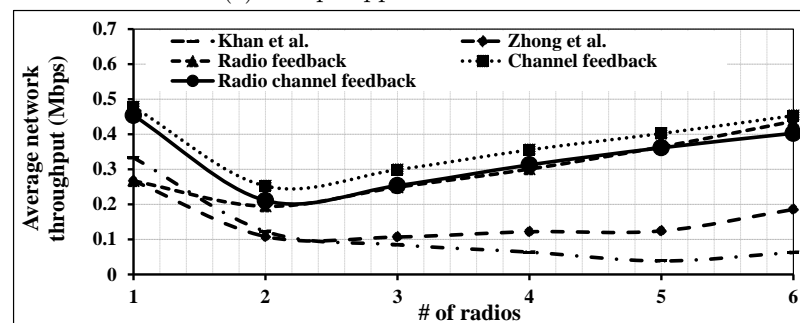

(e) 16Mbps application data rate

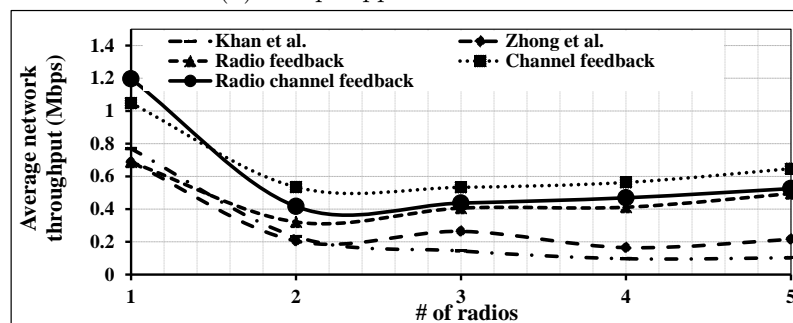

(f) 32Mbps application data rate

Figure A.19: Average packet drop ratio with varying number of radios for various application data rates on a network topology with 32 secondary users

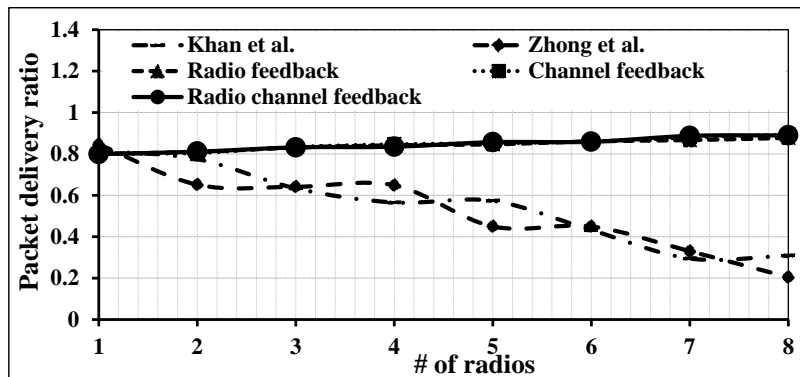

(a) 1Mbps application data rate

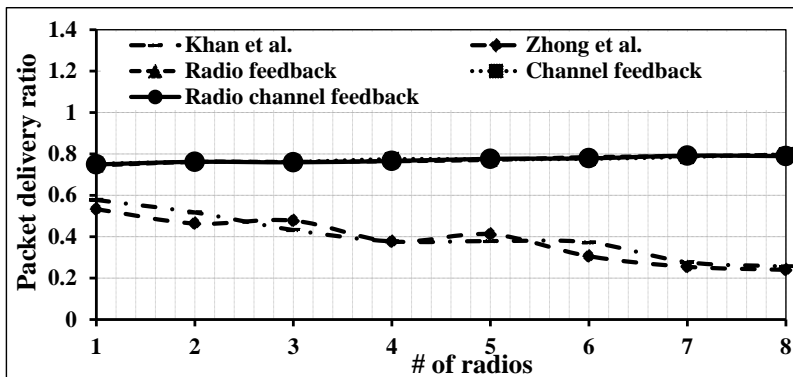

(b) 2Mbps application data rate

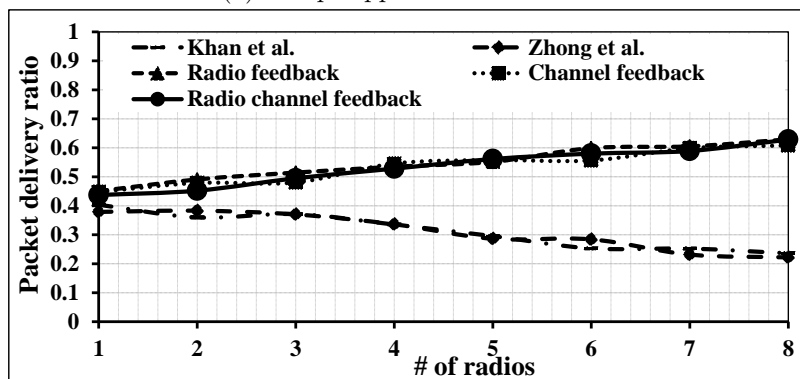

(c) 4Mbps application data rate

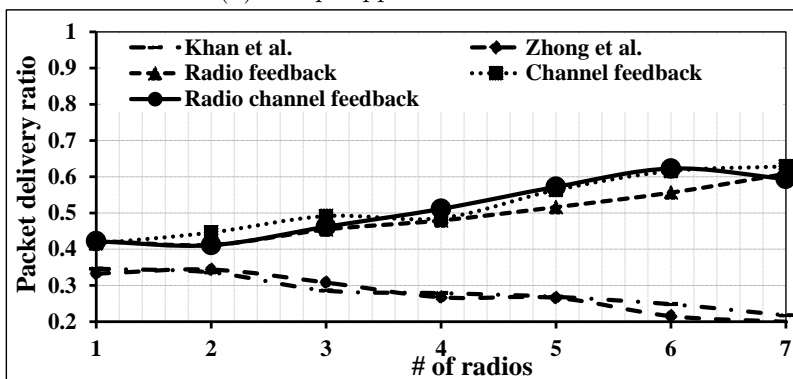

(d) 8Mbps application data rate

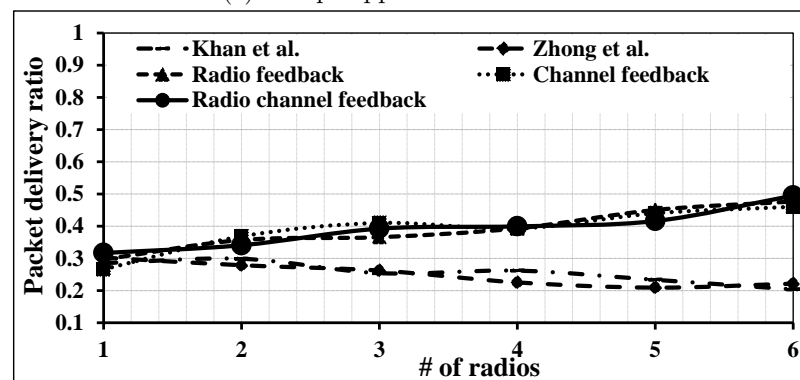

(e) 16Mbps application data rate

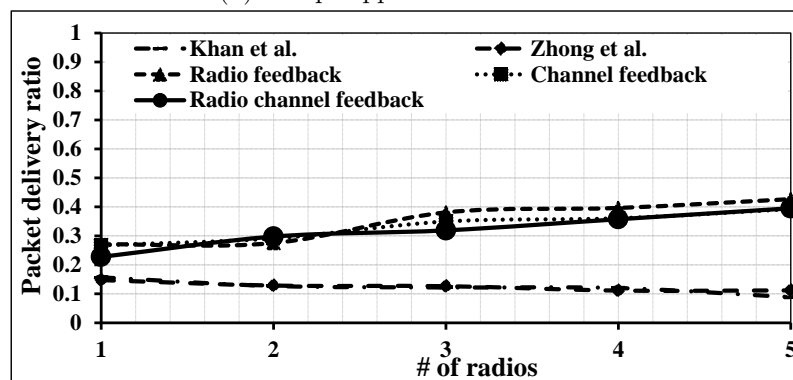

(f) 32Mbps application data rate

Figure A.20: Application layer packet delivery ratio with varying number of radios for various application data rates on a network topology with 32 secondary users

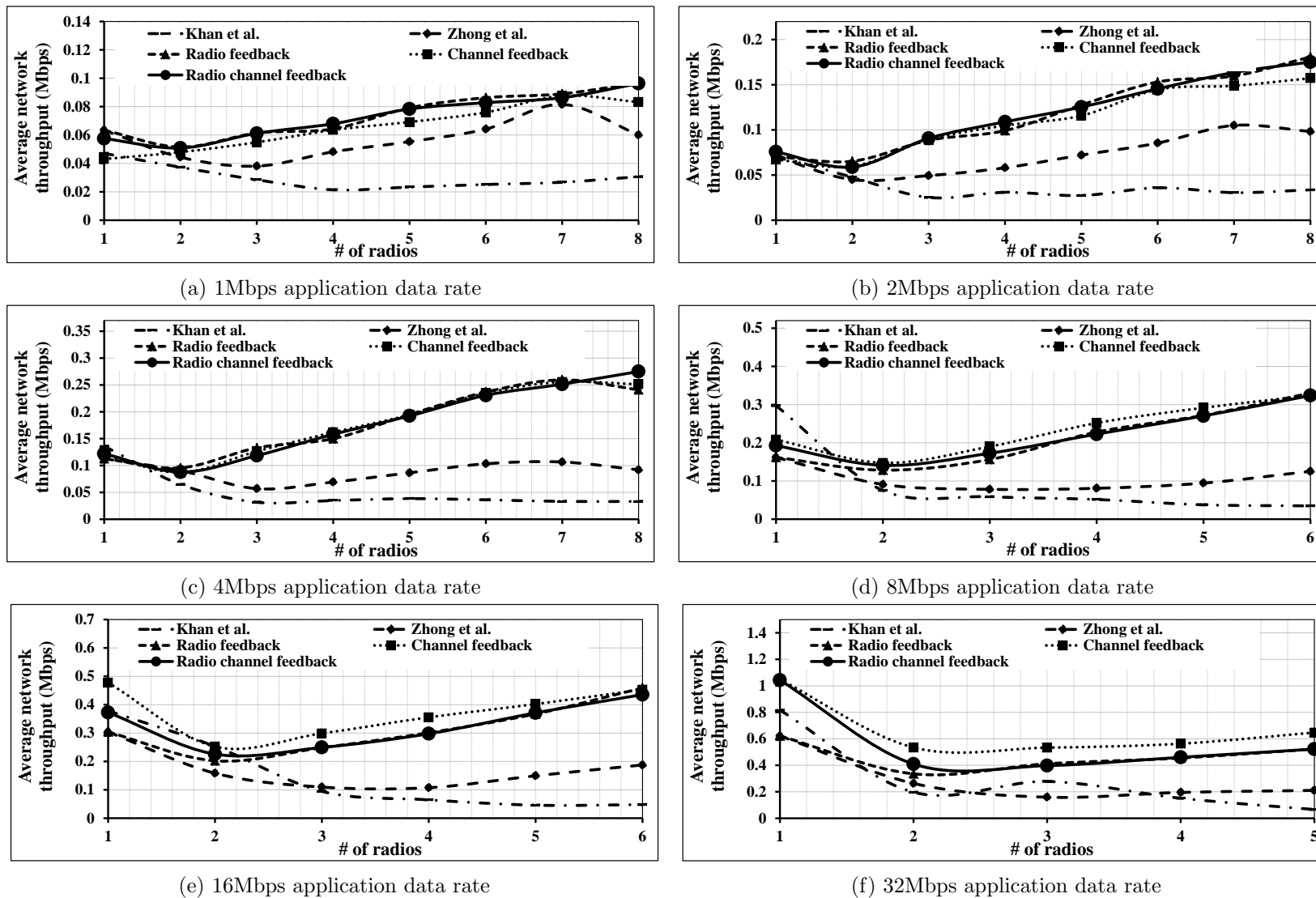

Figure A.21: Average network throughput with varying number of radios for various application data rates on a network topology with 36 secondary users

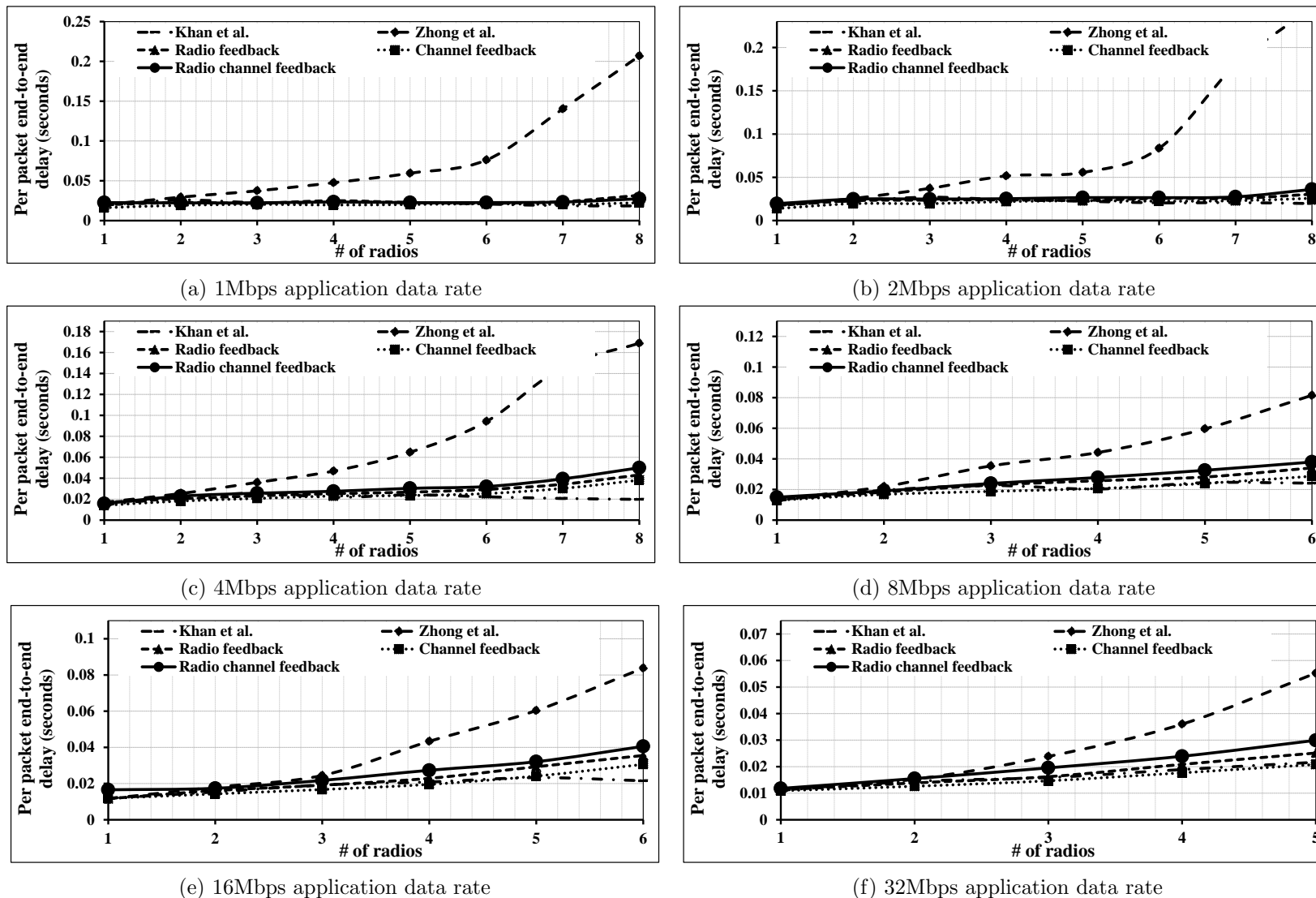

Figure A.22: Average end-to-end delay with varying number of radios for various application data rates on a network topology with 36 secondary users

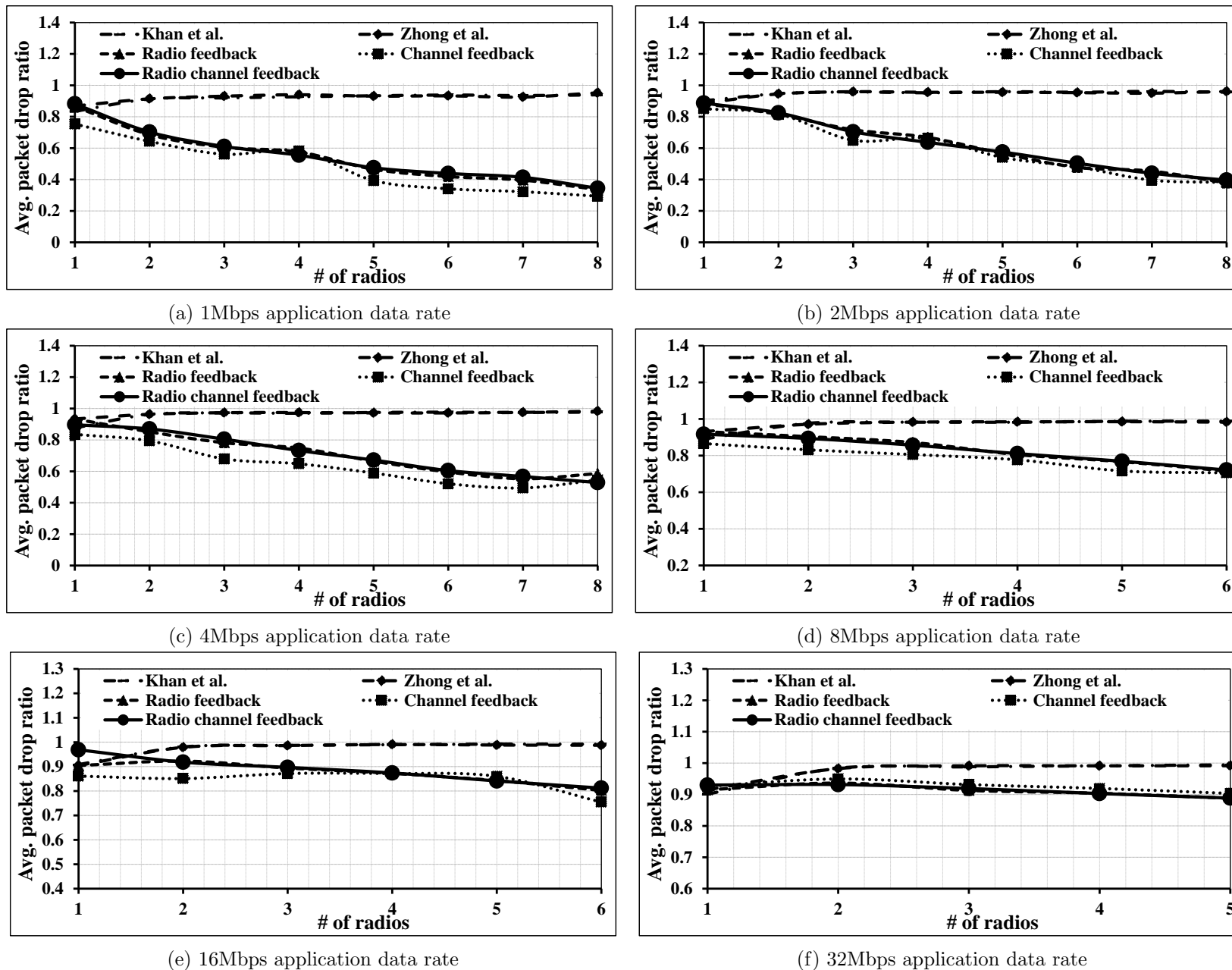

Figure A.23: Average packet drop ratio with varying number of radios for various application data rates on a network topology with 36 secondary users

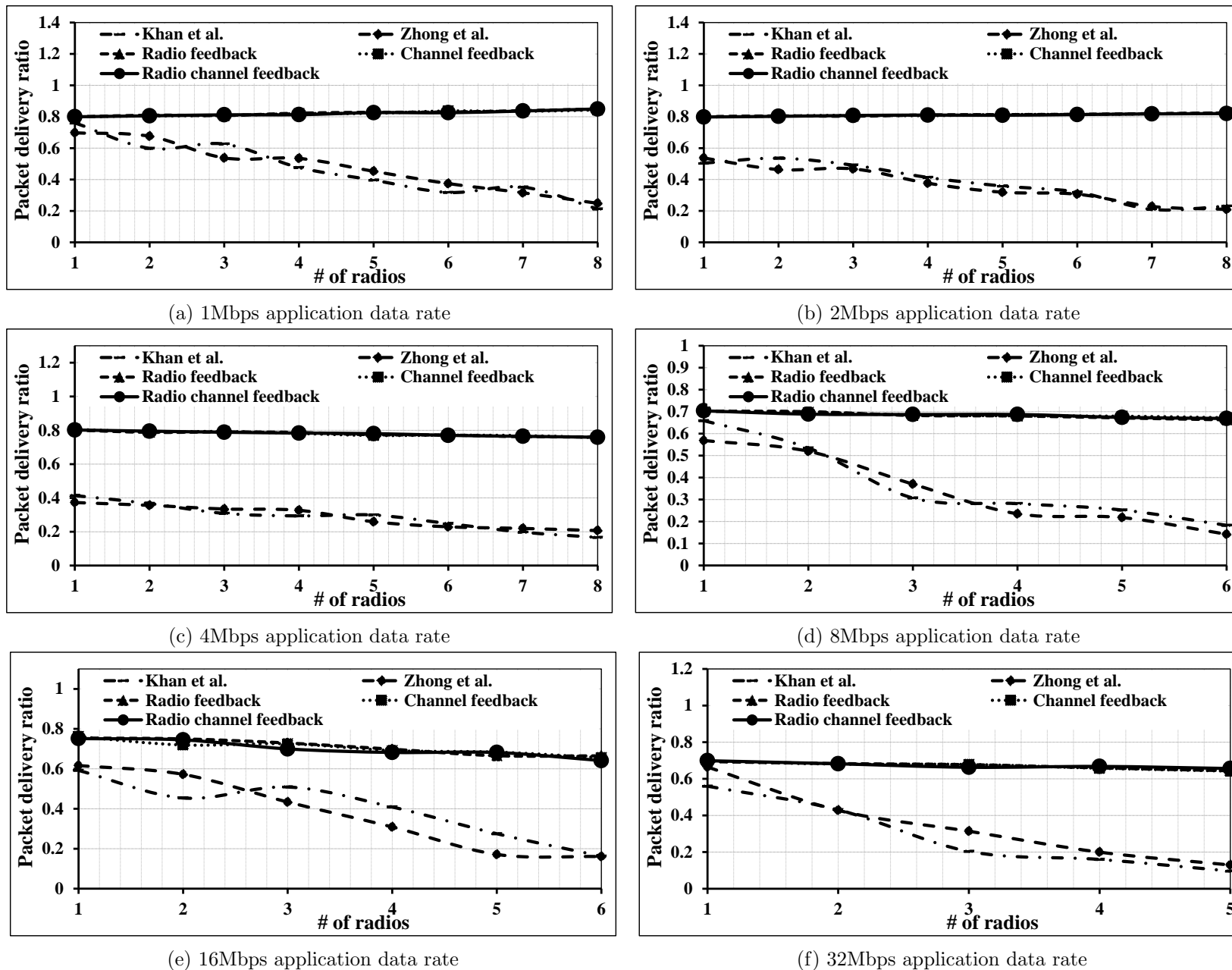

Figure A.24: Application layer packet delivery ratio with varying number of radios for various application data rates on a network topology with 36 secondary users

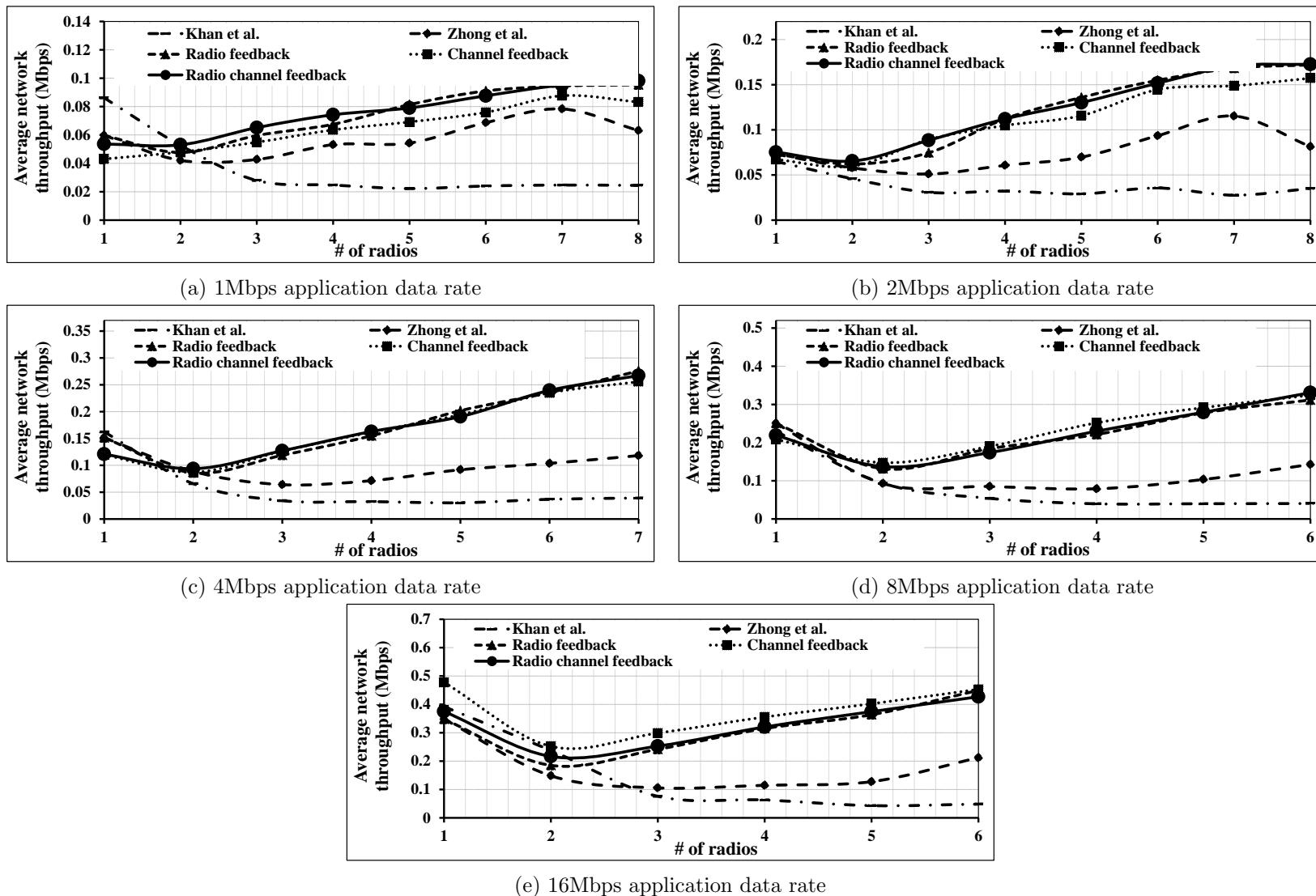

Figure A.25: Average network throughput with varying number of radios for various application data rates on a network topology with 40 secondary users

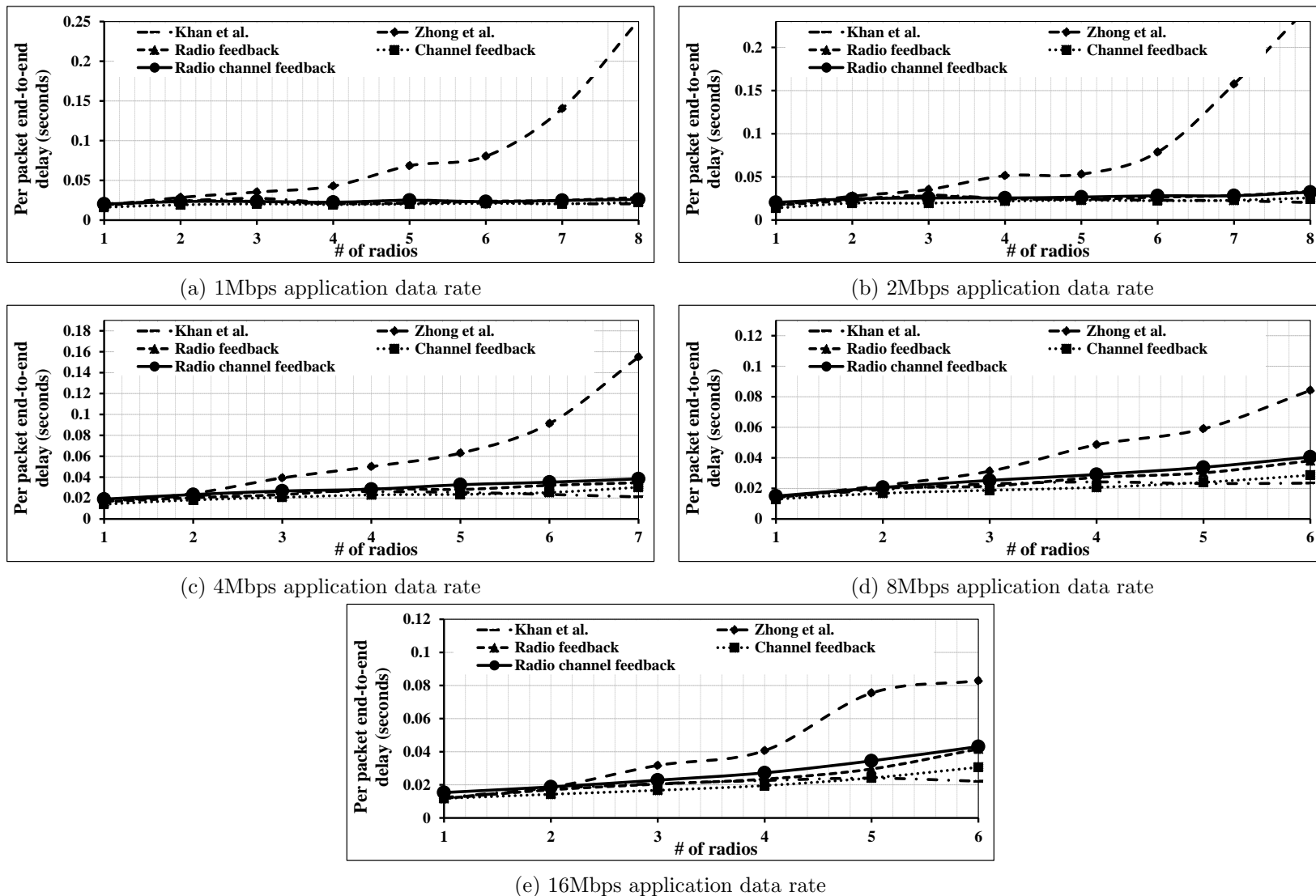

Figure A.26: Average end-to-end delay with varying number of radios for various application data rates on a network topology with 40 secondary users

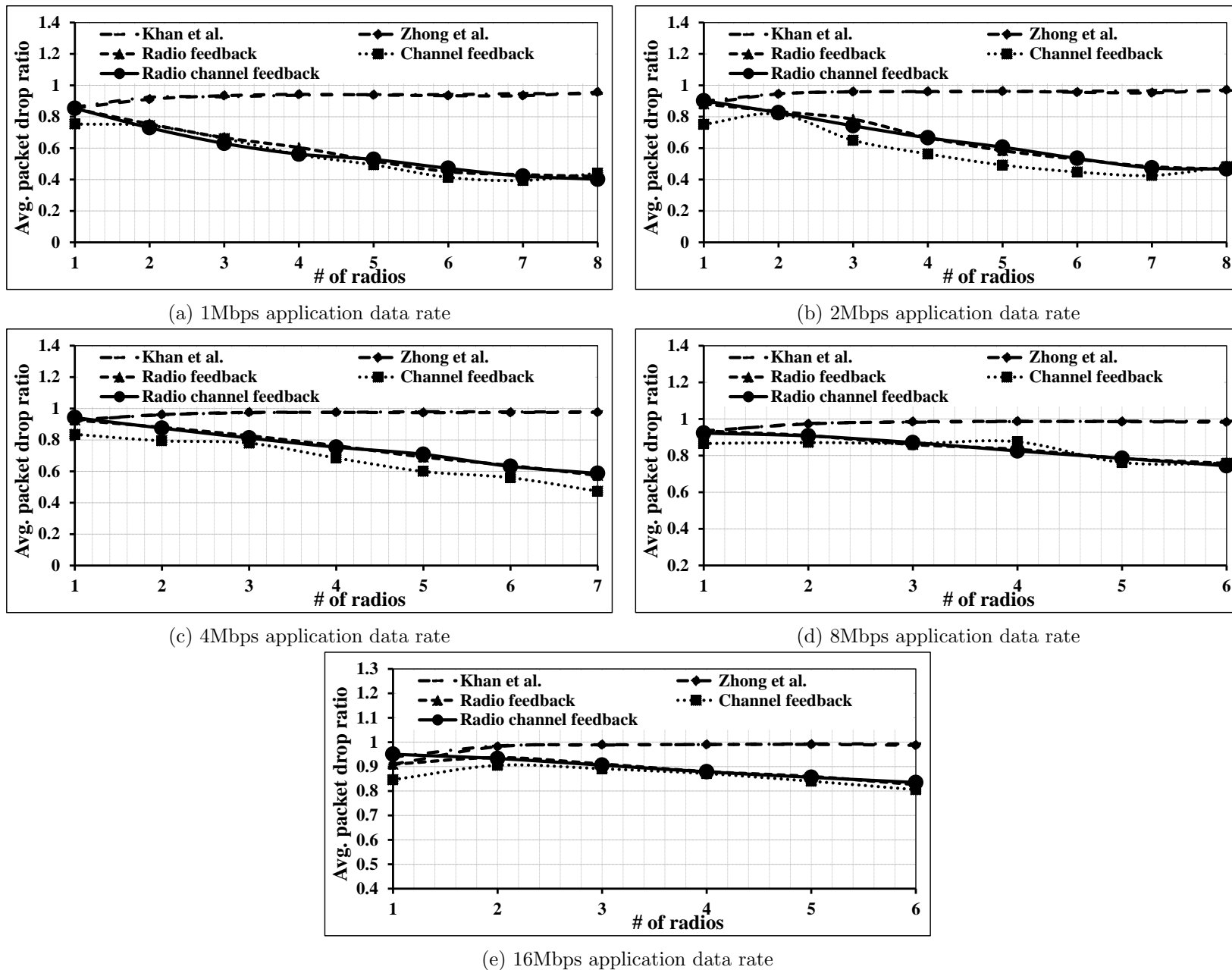
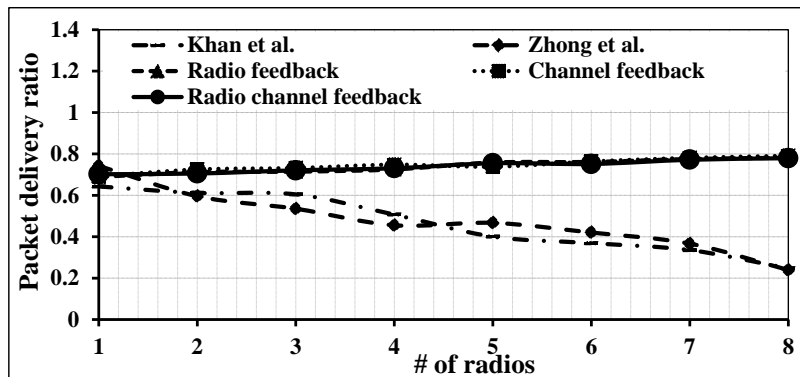
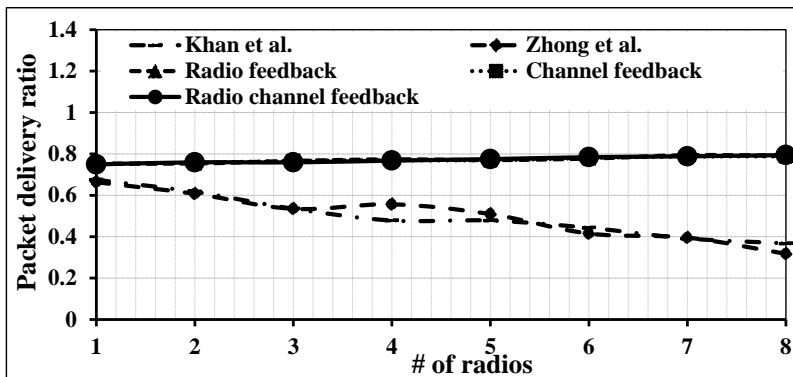

Figure A.27: Average packet drop ratio with varying number of radios for various application data rates on a network topology with 40 secondary users



(a) 1Mbps application data rate



(b) 2Mbps application data rate

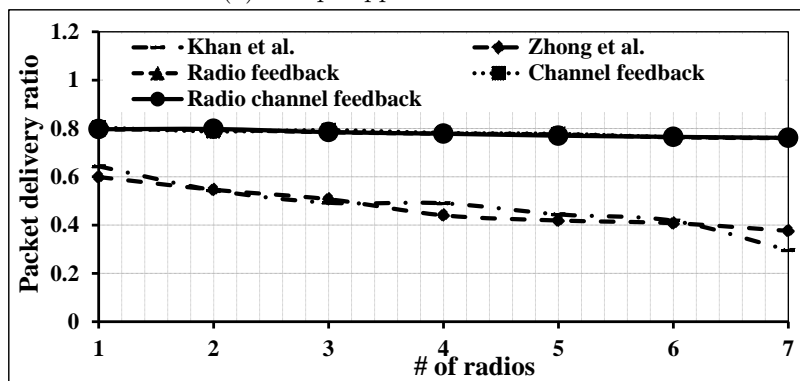

(c) 4Mbps application data rate

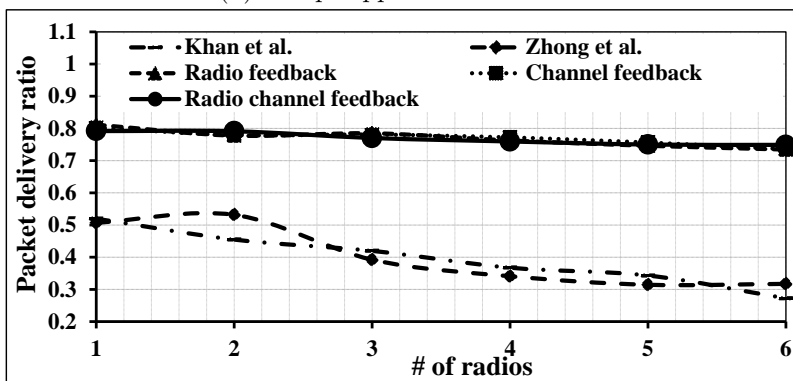

(d) 8Mbps application data rate

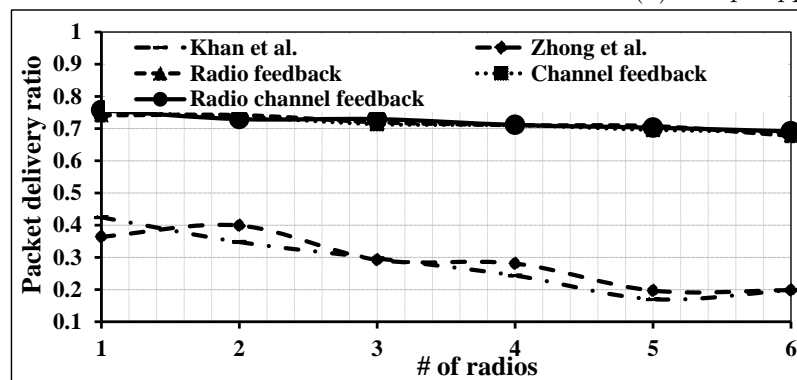

(e) 16Mbps application data rate

Figure A.28: Application layer packet delivery ratio with varying number of radios for various application data rates on a network topology with 40 secondary users

Bibliography

- [1] Tanvir Ahmed Khan, Chowdhury Sayeed Hyder, and ABM Islam. Towards exploiting a synergy between cognitive and multi-radio networking. In *Wireless and Mobile Computing, Networking and Communications (WiMob), 2015 IEEE 11th International Conference on*, pages 370–377. IEEE, 2015.
- [2] Xiaoxiong Zhong, Yang Qin, and Li Li. Capacity analysis in multi-radio multi-channel cognitive radio networks: A small world perspective. *Wireless Personal Communications*, 79(3):2209–2225, 2014.
- [3] Gregory Staple and Kevin Werbach. The end of spectrum scarcity. <http://spectrum.ieee.org/telecom/wireless/the-end-of-spectrum-scarcity>, 2004. (Date last accessed 8-July-2017).
- [4] Václav Valenta, Roman Maršálek, Geneviève Baudoin, Martine Villegas, Martha Suarez, and Fabien Robert. Survey on spectrum utilization in europe: Measurements, analyses and observations. In *Cognitive Radio Oriented Wireless Networks & Communications (CROWNCOM), 2010 Proceedings of the Fifth International Conference on*, pages 1–5. IEEE, 2010.
- [5] Ian F Akyildiz, Won-Yeol Lee, Mehmet C Vuran, and Shantidev Mohanty. Next generation/dynamic spectrum access/cognitive radio wireless networks: a survey. *Computer Networks*, 50(13):2127–2159, 2006.
- [6] Joseph Mitola and Gerald Q. Maguire Jr. Cognitive radio: making software radios more personal. *Personal Communications, IEEE*, 6(4):13–18, 1999.
- [7] Paramvir Bahl, Atul Adya, Jitendra Padhye, and Alec Walman. Reconsidering wireless systems with multiple radios. *ACM SIGCOMM Computer Communication Review*, 34(5):39–46, 2004.

-
- [8] Atul Adya, Paramvir Bahl, Jitendra Padhye, Alec Wolman, and Lidong Zhou. A multi-radio unification protocol for IEEE 802.11 wireless networks. In *Broadband Networks, 2004. BroadNets 2004. Proceedings. First International Conference on*, pages 344–354. IEEE, 2004.
- [9] Richard Draves, Jitendra Padhye, and Brian Zill. Routing in multi-radio, multi-hop wireless mesh networks. In *Proceedings of the 10th annual international conference on Mobile computing and networking*, pages 114–128. ACM, 2004.
- [10] Allen Miu, Hari Balakrishnan, and Can Emre Koksal. Improving loss resilience with multi-radio diversity in wireless networks. In *Proceedings of the 11th annual international conference on Mobile computing and networking*, pages 16–30. ACM, 2005.
- [11] Wei Song and Weihua Zhuang. Performance analysis of probabilistic multipath transmission of video streaming traffic over multi-radio wireless devices. *Wireless Communications, IEEE Transactions on*, 11(4):1554–1564, 2012.
- [12] Guyue Li, Zhaoquan Gu, Xiao Lin, Haosen Pu, and Qiang-sheng Hua. Deterministic distributed rendezvous algorithms for multi-radio cognitive radio networks. In *Proceedings of the 17th ACM international conference on Modeling, analysis and simulation of wireless and mobile systems*, pages 313–320. ACM, 2014.
- [13] Anh Tuan Hoang and Ying-Chang Liang. Downlink channel assignment and power control for cognitive radio networks. *IEEE Transactions on Wireless Communications*, 7(8), 2008.
- [14] Ejaz Ahmed, Abdullah Gani, Saeid Abolfazli, Liu Jie Yao, and Samee U Khan. Channel assignment algorithms in cognitive radio networks: Taxonomy, open issues, and challenges. *IEEE Communications Surveys & Tutorials*, 18(1):795–823, 2014.
- [15] A El Gamal, James Mammen, Balaji Prabhakar, and Devavrat Shah. Throughput-delay trade-off in wireless networks. In *INFOCOM 2004. Twenty-third Annual Joint Conference of the IEEE Computer and Communications Societies*, volume 1. IEEE, 2004.
- [16] Antonio De Domenico, Emilio Calvanese Strinati, and Maria-Gabriella Di Benedetto. A survey on MAC strategies for cognitive radio networks. *IEEE Communications Surveys & Tutorials*, 14(1):21–44, 2012.

- [17] Wei Feng, Jiannong Cao, Chisheng Zhang, and Chuda Liu. Joint optimization of spectrum hand-off scheduling and routing in multi-hop multi-radio cognitive networks. In *Distributed Computing Systems, 2009. ICDCS'09. 29th IEEE International Conference on*, pages 85–92. IEEE, 2009.
- [18] Rahul Tandra, Shridhar Mubaraq Mishra, and Anant Sahai. What is a spectrum hole and what does it take to recognize one? *Proceedings of the IEEE*, 97(5):824–848, 2009.
- [19] Ryan W Thomas, Luiz A DaSilva, and Allen B MacKenzie. Cognitive networks. In *New Frontiers in Dynamic Spectrum Access Networks, 2005. DySPAN 2005. 2005 First IEEE International Symposium on*, pages 352–360. IEEE, 2005.
- [20] Simon Haykin. Cognitive radio: brain-empowered wireless communications. *IEEE journal on selected areas in communications*, 23(2):201–220, 2005.
- [21] Friedrich K Jondral. Software-defined radio: basics and evolution to cognitive radio. *EURASIP journal on wireless communications and networking*, 2005(3):275–283, 2005.
- [22] Federal Communications Commission et al. Notice of proposed rule making and order: Facilitating opportunities for flexible, efficient, and reliable spectrum use employing cognitive radio technologies. *ET docket*, (03-108):73, 2005.
- [23] Danijela Cabric, Shridhar Mubaraq Mishra, and Robert W Brodersen. Implementation issues in spectrum sensing for cognitive radios. In *Signals, systems and computers, 2004. Conference record of the thirty-eighth Asilomar conference on*, volume 1, pages 772–776. Ieee, 2004.
- [24] School of Electrical Broadband Wireless Networking Lab and Georgia Insititute of Technology Computer Engineering. Cognitive radio networks. <http://bwn.ece.gatech.edu/CR/projectdescription.html>, 2006. (Date last accessed 5-July-2017).
- [25] Milind M Buddhikot, Paul Kolodzy, Scott Miller, Kevin Ryan, and Jason Evans. Dimsumnet: new directions in wireless networking using coordinated dynamic spectrum. In *World of Wireless Mobile and Multimedia Networks, 2005. WoWMoM 2005. Sixth IEEE International Symposium on a*, pages 78–85. IEEE, 2005.
- [26] Omer Ileri, Dragan Samardzija, and Narayan B Mandayam. Demand responsive pricing and competitive spectrum allocation via a spectrum server. In *New Frontiers in Dynamic Spectrum*

- Access Networks, 2005. DySPAN 2005. 2005 First IEEE International Symposium on*, pages 194–202. IEEE, 2005.
- [27] Seyed A Zekavat and Xiukui Li. User-central wireless system: ultimate dynamic channel allocation. In *New Frontiers in Dynamic Spectrum Access Networks, 2005. DySPAN 2005. 2005 First IEEE International Symposium on*, pages 82–87. IEEE, 2005.
- [28] Michael Fitch, Maziar Nekovee, Santosh Kawade, Keith Briggs, and Richard MacKenzie. Wireless service provision in tv white space with cognitive radio technology: A telecom operator’s perspective and experience. *IEEE Communications Magazine*, 49(3), 2011.
- [29] Ravi Murty. Software-defined reconfigurability radios: smart, agile, cognitive, and interoperable. *Technology@ Intel Magazine*, 84, 2003.
- [30] David Maldonado, Bin Le, Akilah Hugine, Thomas W Rondeau, and Charles W Bostian. Cognitive radio applications to dynamic spectrum allocation: a discussion and an illustrative example. In *New Frontiers in Dynamic Spectrum Access Networks, 2005. DySPAN 2005. 2005 First IEEE International Symposium on*, pages 597–600. IEEE, 2005.
- [31] John A Stine. Spectrum management: the killer application of ad hoc and mesh networking. In *New Frontiers in Dynamic Spectrum Access Networks, 2005. DySPAN 2005. 2005 First IEEE International Symposium on*, pages 184–193. IEEE, 2005.
- [32] Lars Berlemann, Stefan Mangold, and Bernhard H Walke. Policy-based reasoning for spectrum sharing in radio networks. In *New Frontiers in Dynamic Spectrum Access Networks, 2005. DySPAN 2005. 2005 First IEEE International Symposium on*, pages 1–10. IEEE, 2005.
- [33] Carlson Wireless Technology. Ruralconnect - tv white spaces radio. <http://www.carlsonwireless.com/ruralconnect/>. (Date last accessed 9-July-2017).
- [34] Jose A Gutierrez, Marco Naeve, Ed Callaway, Monique Bourgeois, Vinay Mitter, and Bob Heile. Ieee 802.15. 4: a developing standard for low-power low-cost wireless personal area networks. *IEEE network*, 15(5):12–19, 2001.
- [35] Ashish Raniwala and Tzi-cker Chiueh. Architecture and algorithms for an ieee 802.11-based multi-channel wireless mesh network. In *INFOCOM 2005. 24th Annual Joint Conference of the*

- IEEE Computer and Communications Societies. Proceedings IEEE*, volume 3, pages 2223–2234. IEEE, 2005.
- [36] JC-P Wang, Mehran Abolhasan, Farzad Safaei, and D Franklin. A survey on control separation techniques in multi-radio multi-channel mac protocols. In *Communications and Information Technologies, 2007. ISCIT'07. International Symposium on*, pages 854–859. IEEE, 2007.
- [37] Bong-Jun Ko, Vishal Misra, Jitendra Padhye, and Dan Rubenstein. Distributed channel assignment in multi-radio 802.11 mesh networks. In *Wireless Communications and Networking Conference, 2007. WCNC 2007. IEEE*, pages 3978–3983. IEEE, 2007.
- [38] ABM Alim Al Islam, Md Jahidul Islam, Novia Nurain, and Vijay Raghunathan. Channel assignment techniques for multi-radio wireless mesh networks: A survey. *IEEE Communications Surveys & Tutorials*, 18(2):988–1017, 2016.
- [39] Vijay Gabale, Bhaskaran Raman, Partha Dutta, and Shivkumar Kalyanraman. A classification framework for scheduling algorithms in wireless mesh networks. *IEEE Communications Surveys & Tutorials*, 15(1):199–222, 2013.
- [40] Pradeep Kyasanur and Nitin H Vaidya. Routing and link-layer protocols for multi-channel multi-interface ad hoc wireless networks. *ACM SIGMOBILE Mobile Computing and Communications Review*, 10(1):31–43, 2006.
- [41] Avhishek Chatterjee, Supratim Deb, Kanthi Nagaraj, and Vikram Srinivasan. Low delay mac scheduling for frequency-agile multi-radio wireless networks. 2013.
- [42] Claudia Cormio and Kaushik R Chowdhury. A survey on mac protocols for cognitive radio networks. *Ad Hoc Networks*, 7(7):1315–1329, 2009.
- [43] Guo-Mei Zhu, Ian F Akyildiz, and Geng-Sheng Kuo. Stod-rp: A spectrum-tree based on-demand routing protocol for multi-hop cognitive radio networks. In *Global Telecommunications Conference, 2008. IEEE GLOBECOM 2008. IEEE*, pages 1–5. IEEE, 2008.
- [44] Maryam Ahmadi, Yanyan Zhuang, and Jianping Pan. Distributed robust channel assignment for multi-radio cognitive radio networks. In *Vehicular Technology Conference (VTC Fall), 2012 IEEE*, pages 1–5. IEEE, 2012.

-
- [45] Duncan J Watts and Steven H Strogatz. Collective dynamics of 'small-world' networks. *nature*, 393(6684):440, 1998.
- [46] Sheldon M. Ross. *Introduction to Probability Models, Ninth Edition*. Academic Press, Inc., Orlando, FL, USA, 2006.
- [47] Amir Ghasemi and Elvino S Sousa. Spectrum sensing in cognitive radio networks: requirements, challenges and design trade-offs. *IEEE Communications Magazine*, 46(4), 2008.
- [48] Ian F Akyildiz, Won-Yeol Lee, and Kaushik R Chowdhury. Crahns: Cognitive radio ad hoc networks. *AD hoc networks*, 7(5):810–836, 2009.
- [49] Kaigui Bian and Jung-Min Park. Asynchronous channel hopping for establishing rendezvous in cognitive radio networks. In *INFOCOM, 2011 Proceedings IEEE*, pages 236–240, 2011.
- [50] Brandon F Lo. A survey of common control channel design in cognitive radio networks. *Physical Communication*, 4(1):26–39, 2011.
- [51] Karaputugala G Madushan Thilina, Ekram Hossain, and Dong In Kim. DCCC-MAC: a dynamic common-control-channel-based mac protocol for cellular cognitive radio networks. *IEEE Transactions on Vehicular Technology*, 65(5):3597–3613, 2016.
- [52] M. Tessmer, L. Cannon, C. Centuori, and A. Williams. Method and system for weighting odds to specific gaming entities in a shared bonus event, May 31 2007. US Patent App. 11/669,013.
- [53] Y. Wang, Y. Song, and M. Liang. A skyline-based efficient web service selection method supporting frequent requests. In *2016 IEEE 20th International Conference on Computer Supported Cooperative Work in Design (CSCWD)*, pages 328–333, May 2016.
- [54] Abdulla Al-Ali and Kaushik Chowdhury. Simulating dynamic spectrum access using ns-3 for wireless networks in smart environments. In *Sensing, Communication, and Networking Workshops (SECON Workshops), 2014 Eleventh Annual IEEE International Conference on*, pages 28–33. IEEE, 2014.
- [55] Junghyun Heo, Jungchae Shin, Jihee Nam, Yutae Lee, Joon Goo Park, and Ho-Shin Cho. Mathematical analysis of secondary user traffic in cognitive radio system. In *Vehicular Technology Conference, 2008. VTC 2008-Fall. IEEE 68th*, pages 1–5. IEEE, 2008.

- [56] Wayne L Winston. *Simulation modeling using@ RISK*. Duxbury, 2000.