

L-2/T-2/ARCH

Date: 17/02/2018

BANGLADESH UNIVERSITY OF ENGINEERING AND TECHNOLOGY, DHAKA

L-2/T-2 B. Arch. Examinations 2016-2017

Sub: **ARCH 261** (Construction Methods and Details)

Full Marks: 140

Time: 3 Hours

USE SEPARATE SCRIPTS FOR EACH SECTION

The figures in the margin indicate full marks

SECTION – A

There are **FOUR** questions in this section. Answer **Q. No. 4** and any **TWO** from the rest.

1. (a) What do you understand by the term 'Foundation'? (4+6+10=20)
(b) What are the purposes of providing foundation?
(c) Why information regarding soil of the site is necessary before starting structural design of a building?
2. Write down the construction technique of Terrazo flooring and Glazed tiles flooring. (20)
3. What are the general principles to be observed in brick masonry construction? (20)
4. Write short notes on the following: (2×15=30)
 - (i) Pre-cast piles
 - (ii) Cast-in-situ piles

SECTION – B

There are **FOUR** questions in this section. Answer **Q. No. 5** and any **TWO** from the rest.

5. Write short notes on the following roofing system. (15×2=30)
 - (a) King Post Truss
 - (b) Queen Post Truss
 6. (a) What are the defects caused by dampness in a building? (10)
(b) Discuss the sources of dampness in buildings. (10)
 7. Describe membrane and integral damp proofing methods. (20)
 8. What are the basic requirements of a good stair? Discuss them briefly. (20)
-

SECTION – A

There are **FOUR** questions in this section. Answer **Q. No. 4** and any **TWO** from the rest.

1. (a) Briefly write about 'Samsara' and 'Nirvana'. (5)
(b) Which one of the Hinayana type chaitya hall reached its culmination? Describe with plan and necessary sketches. (15)
2. (a) Discuss the theme and layout of the Sun temple at Konarak. Show the evidences to justify, why it appears to be never complete. (15)
(b) Write down the architectural characteristics of Gupta temple. (5)
3. (a) What can you tell us about 'Gopuram'? (5)
(b) What are the underlying thoughts that generated the 'Fort' like planning layout of Madurai Temple? (15)
4. Write short notes on any two: (15×2=30)
(a) Shore temple
(b) Frescos of Ajanta
(c) Changes in Shikhara of North Indian temples.

SECTION – B

There are **FOUR** questions in this section. Answer **Q. No. 8** and any **TWO** from the rest.

5. Critically describe the following aspects of 'Fatehpur Sikri' with illustrations: (25)
(a) Concept of multiple axis in its planning
(b) Visual unity and diversity
(c) Building materials and pavements
6. (a) Describe the tomb of Humayun as a fusion and logical synthesis of two great architectural traditions with necessary illustrations. (12)
(b) 'Tajmahal is a complete architectural experience' — explain with reference to its design concept and zoning. Use necessary sketches. (13)

ARCH 331

7. (a) Draw sketches to show the evolution of arches including those in 'Quwat-ul-Islam' Mosque, 'Alai Darwaza' and 'Tomb of Ghiyas-ud-din-Tuglaq. (15)
- (b) Briefly write about 'Tomb of Iltutmish'. (10)
8. Write short notes on any two of the following: (10×2=20)
- (a) Mughal Garden
- (b) Delhi jame masjid
- (c) Buland Darwaza.
-

SECTION – A

There are **FIVE** questions in this section. Answer **Q. No. 1** and any **THREE** from the rest.

1. (a) (i) Calculate the Reverberation Time (RT) at 1 kHz for the room shown in Fig. for Q. 1(a). **(12+2=14)**
(ii) Make comments on suitability of the room for speech in Bangla.
(b) Write short notes on any TWO of the following: **(4+4=8)**
 - (i) Sound Transmission Class (STC)
 - (ii) Reverberation Time (RT)
 - (iii) Absorption Coefficient.

2. (a) Determine the total absorption at 500 Hz by the wall (including the opening) as shown in Fig. for Q 2(a). **(8)**
(b) Does the suspended ceiling in Fig. for Q 2(b) perform as a diffuser for a sound velocity of 340 m/s, in cases of sound frequencies of (i) 100 Hz and (ii) 1 kHz? **(4+4=8)**

3. Prepare acoustic design requirements for any TWO of the following spaces. **(8+8=16)**
[Reference: Table for Q. 3(a) and Fig. for Q. 3(b).]
 - (i) Classroom
 - (ii) Bed Room
 - (iii) Theatre

4. Describe with figures how noise transmission can be controlled in following conditions: **(4×4=16)**
 - (i) From room to room through air-conditioning ducts
 - (ii) From floor to floor through floor slabs due to mechanical equipment
 - (iii) From outdoor to indoor through walls
 - (iv) From outdoor to indoor through windows due to reflection from sunshade and balconies.

5. (a) In schematic plans, show examples of 'poor' and 'good' acoustic treatments for a space of circular plan. **(4)**
(b) In schematic sections, show examples of 'poor' and 'good' acoustic options for ceiling and balcony design of an auditorium. **(4)**
(c) Explain the statement: "Acoustic performance of a space should not be assumed as a post-construction assignment, rather it should be ensured in the design phase." **(8)**

ARCH 255

SECTION – B

There are **FIVE** questions in this section. Answer **Q. No. 6** and any **THREE** from the rest.

6. (a) (i) Define sound physically and psychophysically? **(2+12=14)**
(ii) Mention briefly the properties of sound.
- (b) Write short notes (any TWO): **(4×2=8)**
(i) Velocity of sound
(ii) Wavelength of sound
(iii) Frequency of sound.
7. Briefly mention significant contributions by Pythagoras, Aristotle, Vitruvius, Galileo, Newton, Helmbotz, Rayleigh and Sabine in the development of acoustics. **(16)**
8. Explain with schematic drawings, how does sound behave in an enclosed space for absorption, reflection, diffraction and refraction? **(4×4=16)**
9. Elucidate following singular phenomena with necessary sketches and examples: **(4×4=16)**
(i) Echo
(ii) Flutler Echo
(iii) Sound focus and dead spot
(iv) Whispering Gallery.
10. Describe the unique features of human perception of sound in terms of frequency and loudness. **(16)**
-

Fig. for Q 1 (a)

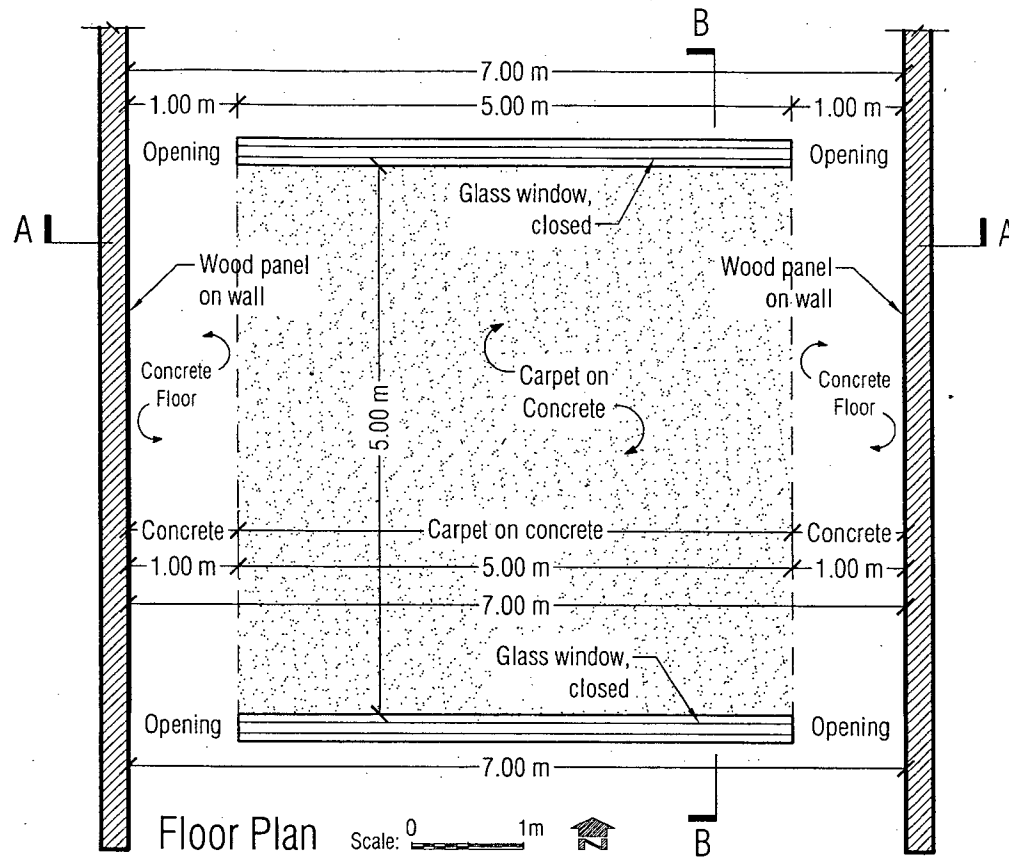

Materials	Absorption Coefficient		
	250 Hz	500 Hz	1 kHz
1 Concrete	0.01	0.02	0.02
2 Carpet on concrete	0.06	0.14	0.37
3 Glass	0.06	0.04	0.03
4 Wood panel on wall	0.22	0.17	0.09
5 Brick, exposed	0.03	0.03	0.04

Note: Ignore absorption by the volume of air in the room

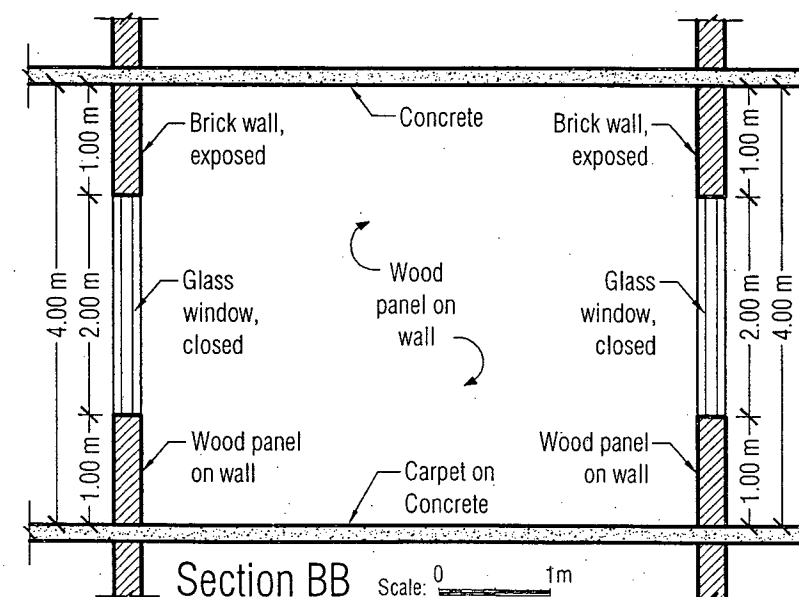
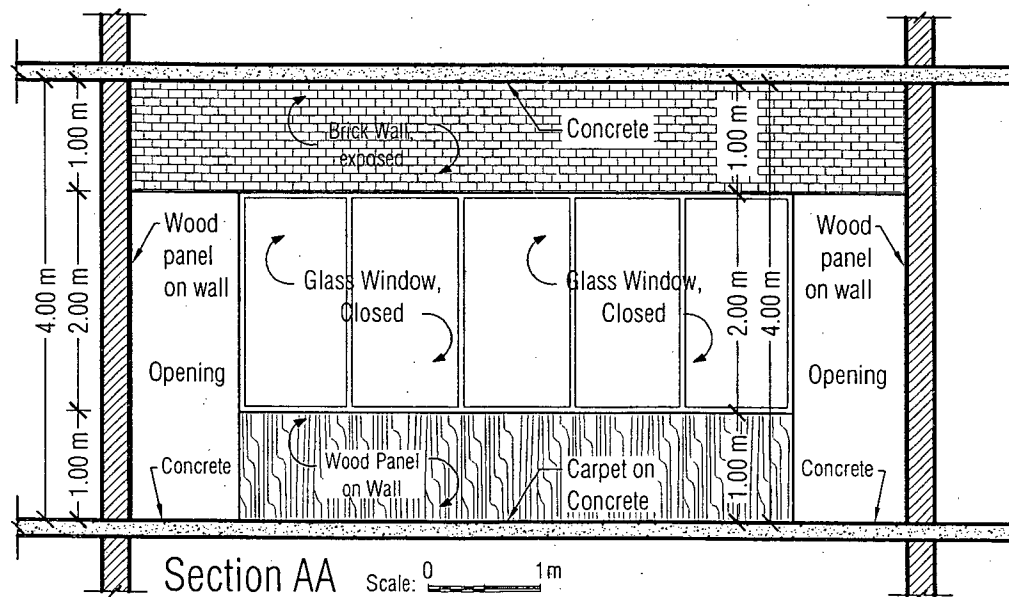

= 3 =

L2/T2/ARCH

ARCH 255

Fig. for Q 2(a)

Absorption Coefficient of Materials			
Materials	Absorption Coefficient		
	250 Hz	500 Hz	1 kHz
Exposed Concrete	0.02	0.04	0.06
Wood panel	0.25	0.20	0.17
Exposed Brick	0.03	0.03	0.04

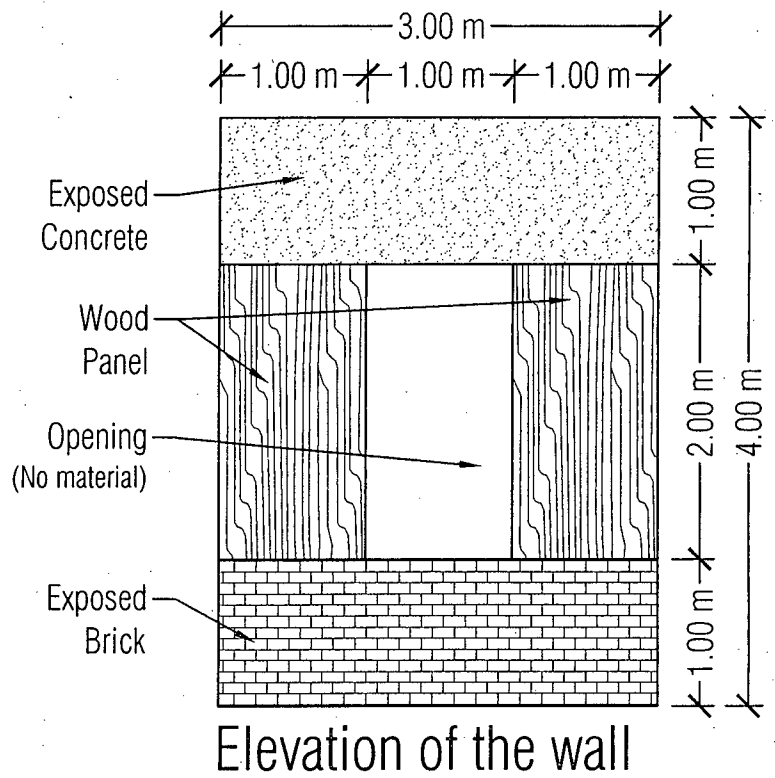
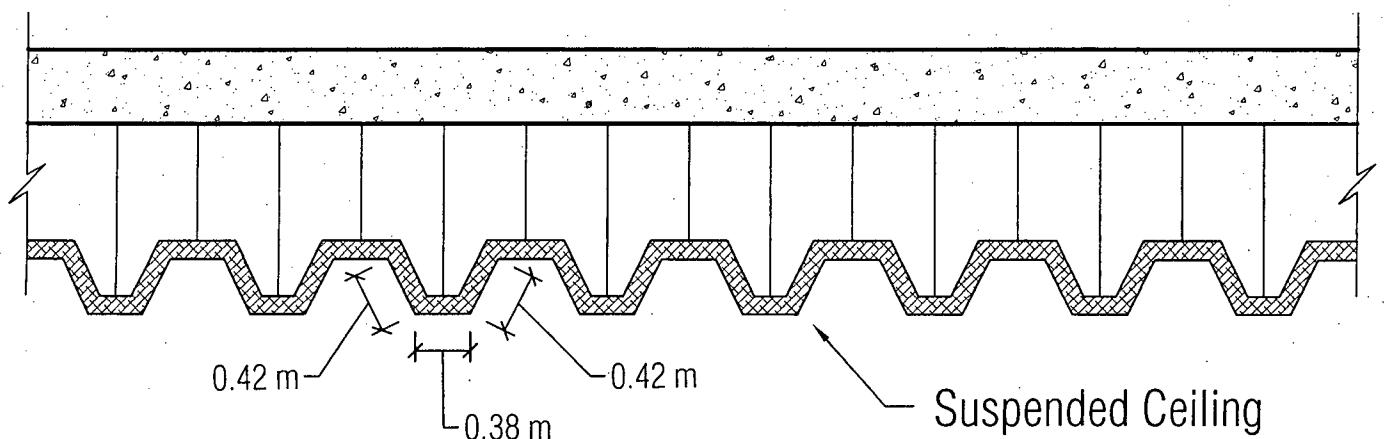

Fig. for Q 2(b)



Section of the Suspended Ceiling

Table for Q 3 (a)

Allowable Upper Limit of Indoor Background Noise Levels and Recommended Range of NCB Curves

(Source: Maekawa Z., Lord P. 1994. *Environmental and Architectural Acoustics*. E&FN SPON, UK)

Type of space	dBA	NCB Curve
Broadcast and recording studios (distant microphone used)	18	10
Concert halls, opera houses, and recital halls	18-23	10-15
Large theatres and auditoriums, mosques, temples, churches and other prayer spaces	<28	<20
Television and recording studio (close microphone used)	<33	<25
Small theatres, auditoriums, music, rehearsal rooms, large meeting and conference rooms	<38	<30
Bedrooms, hospitals, hotels, residences, apartments, etc.	33-48	25-40
Classrooms, libraries, small offices and conference rooms. Living rooms, and drawing rooms in dwellings	38-48	30-40
Large offices, receptions, retail shops and stores, cafeterias, restaurants, indoor stadiums, gymnasium, large seating-capacity spaces with speech amplification	43-53	35-45
Lobbies, laboratory, drafting rooms, and general offices	48-58	40-50
Kitchens, laundries, computer and maintenance shops	53-63	45-55
Shops, garages, etc. (for just acceptable telephone conversation)	58-68	50-60
For work spaces where speech is not required	63-78	55-70

Fig. for Q 3 (b)

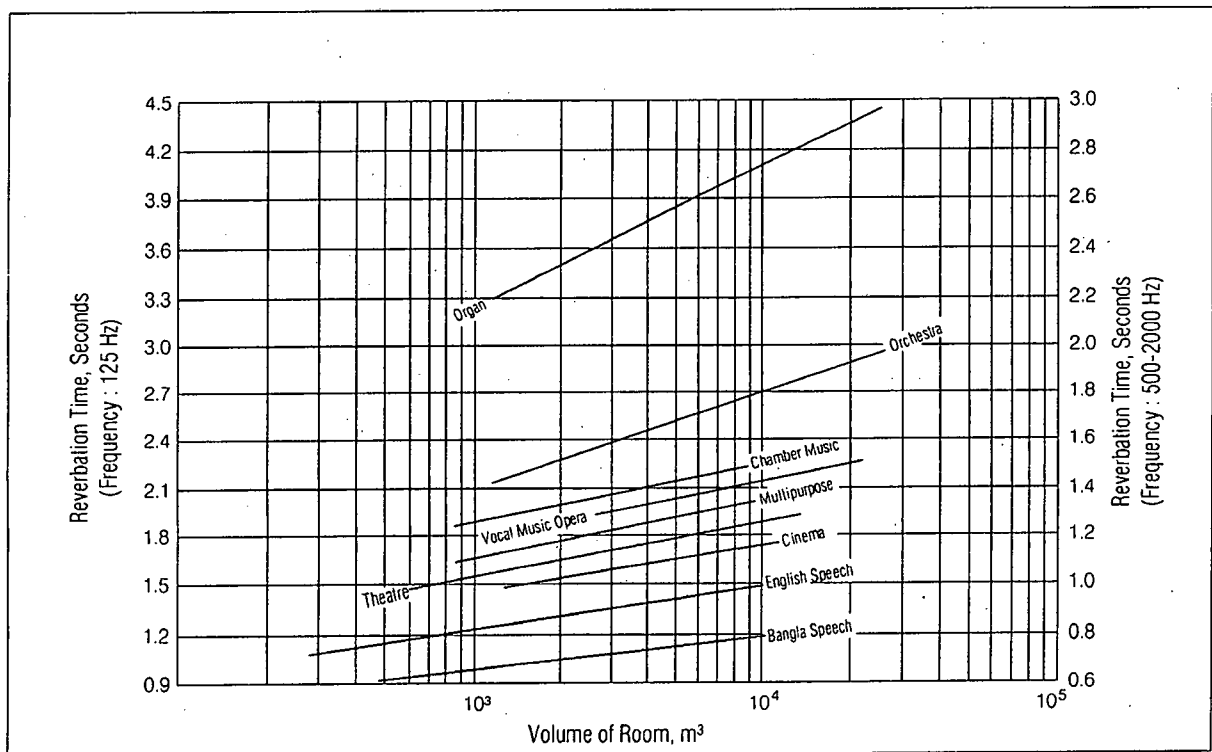

Fig. Recommended optimum reverberation times for spaces of various uses

Notes:

1. The optimum RT for speech is shown here for English and Bangla language. It might be noted that the recommended optimum RT for speech in Bangla ranges from 0.5 s to 0.8 s.
2. The figure shows optimum RT for Western music and English vocals. For local music of Bangladesh, optimum RT might be assumed from its typological similarity to that of Western music.

L-2/T-2/ARCH

Date: 22/02/2018

BANGLADESH UNIVERSITY OF ENGINEERING AND TECHNOLOGY, DHAKA

L-2/T-2 B. Arch Examinations 2016-2017

Sub: **ARCH 235** (Architecture of Modern Period)

Full Marks: 140

Time: 3 Hours

The figures in the margin indicate full marks.

USE SEPARATE SCRIPTS FOR EACH SECTION

SECTION – A

There are **FOUR** questions in this section. Answer **Q. No. 4** and any **TWO** from the rest.

1. Briefly discuss the 'Five Points in Architecture' according to Le Corbusier with reference to Villa Savoye. (20)
2. Describe 'Fransworth House' to explain the famous dictum 'Less in More' by Mies Van der Rohe. (20)
3. What is 'Chicago School of Architecture'? Discuss its significance in the history of Modern Architecture? Who were the key figures involved in it? (20)
4. Write short notes on any two. (15×2=30)
 - (a) CIAM.
 - (b) Bauhaus.
 - (c) Crystal Palace.

SECTION – B

There are **FOUR** questions in this section. Answer **Q. No. 8** and any **TWO** from the rest.

5. What according to Kenneth Frampton is 'Structural Classicism'? How is it related to the core idea of 'Primitive Hut' as described by Laugier? (20)
 6. Is Falling Water, the Kauffman House, a piece of modern architecture? Describe it as the finest creation of Frank Lloyd Wright. (20)
 7. What do you understand by the terms– (20)
modernism, modernity and modernization.
What are the ten paradigms of enlightenment?
 8. Write short notes on any two: (15×2=30)
 - (a) Pre Raphaelite Brotherhood
 - (b) Expressionism
 - (c) Deutsche Werkbund.
-

The figures in the margin indicate full marks.

USE SEPARATE SCRIPTS FOR EACH SECTION

SECTION – A

There are **FOUR** questions in this section. Answer any **THREE**.

1. (a) A steel loop $ABCD$ of length 1.2 m and of 10-mm diameter is placed as shown in Figure 1 around a 24-mm-diameter aluminum rod AC . Cables BE and DF , each of 12-mm diameter, are used to apply the load Q . Knowing that the ultimate strength of the steel used for the loop and the cables is 480 MPa and that the ultimate strength of the aluminum used for the rod is 260 MPa, determine the largest load Q that can be applied if an overall factor of safety of 3 is desired. (13 $\frac{1}{3}$)

(b) The steel frame ($E = 200$ GPa) shown has a diagonal brace BD with an area of 1920 mm². Determine the largest allowable load P if the change in length of member BD is not to exceed 1.6 mm. (Figure 2) (10)
2. (a) Determine the deformation of the steel rod shown in Figure 3 under the given loads ($E = 29 \times 10^6$ psi). (12)

(b) Find the stress in the mast of the derrick shown in the Figure 4. All members are in the same vertical plane and joined by pins. The mast is made from an 8-in standard steel pipe weighing 28.55 lb/ft. Neglect the weight of the members. Area of the pipe = 8.40 in². (11 $\frac{1}{3}$)
3. (a) A single angle tension member, $L 4 \times 4 \times \frac{3}{8}$ in. made from A36 steel is connected to a gusset plate with $\frac{5}{8}$ in. diameter bolts, as shown in Figure 5. The service loads are 35 kips dead load and 15 kips live load. Determine the adequacy of this member using AISC specification. Assume that the effective net area is 85% of the computed net area. Gross area of angle = $A_g = 2.86$ in². (11)

(b) Calculate the maximum shearing, tearing and bearing stresses in the riveted joint shown in Figure 6, when subjected to a force $P = 50$ k. Also comment on the adequacy of the joint if the allowable shearing, tearing and bearing stresses are 17, 22 and 27 ksi respectively. (12 $\frac{1}{3}$)

CE 267/ARCH

4. (a) Design the welded connection for double Channel section tension member shown in Figure 7 to carry a factored load of 300 kips. All steel are A36 steel ($f_y = 36$ ksi, $f_u = 50$ ksi). (15)
- (b) In Figure 8 shown below, calculate the length of 3/8-inch weld joints required on sides AB and CD only to connect the 0.5" thick angle section ABCD to the 0.625" thick plate EFGH. Axial force of 70 kips passes through centroid of ABCD [Given: Allowable shear stress = 16 ksi]. (8 1/3)

SECTION – B

There are **FOUR** questions in this section. Answer any **THREE**.

5. (a) For the beam shown in Figure 9, find the reactions at the supports and the bending moment at point A using Section method. (10 1/3)
- (b) Draw shear force and bending moment diagrams for the beam shown in Figure 10. Use integration method. (13)
6. (a) For the frame shown in Figure 11, determine the shear force and bending moment at point A using Section method. (8 1/3)
- (b) Draw shear force and bending moment diagrams for the frame shown in Figure 11. (15)
7. (a) For the bracket in Figure 12, determine the deflection of point B caused by the applied vertical force of $P=5$ kips. Also determine the vertical stiffness of the bracket at B. Assume that the members are made of 2024-T4 Aluminum alloy with $E = 10.6 \times 10^3$ ksi. Cross-sectional areas of AB and BC are 0.125 inch^2 and 0.20 inch^2 , respectively. (15 1/3)
- (b) Determine the deflection of free end B of a 1 inch diameter circular elastic bar OB (Figure 13) caused by its own weight of 5 lb/inch^3 . Total length of the bar is 5 ft. ($E = 29000$ ksi). (8)
8. (a) Define the terms (i) Engineering stress (ii) True Stress. (6)
- (b) Draw a qualitative stress-strain diagram of mild steel showing its various components. (6)
- (c) Define shear force and bending moment along with their sign conventions. (6)
- (d) State Hooke's law and write down the definition of Poisson's Ratio. (5 1/3)
-

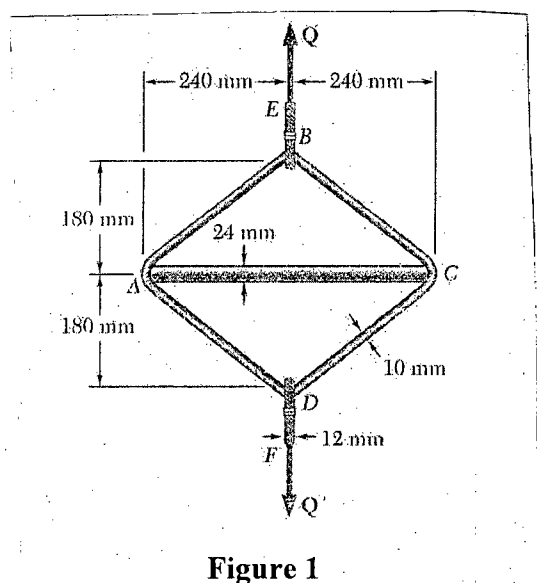

Figure 1

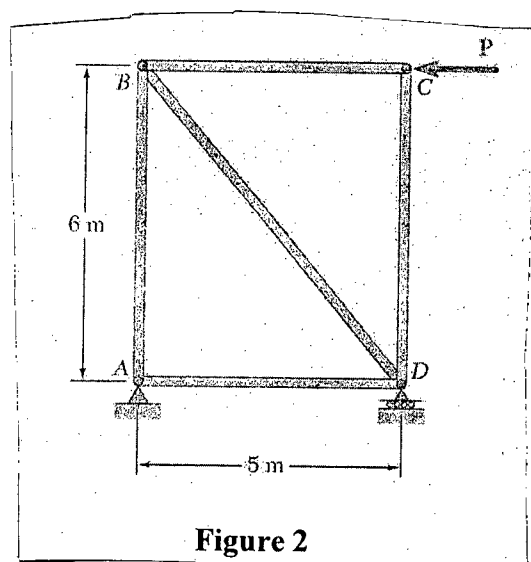

Figure 2

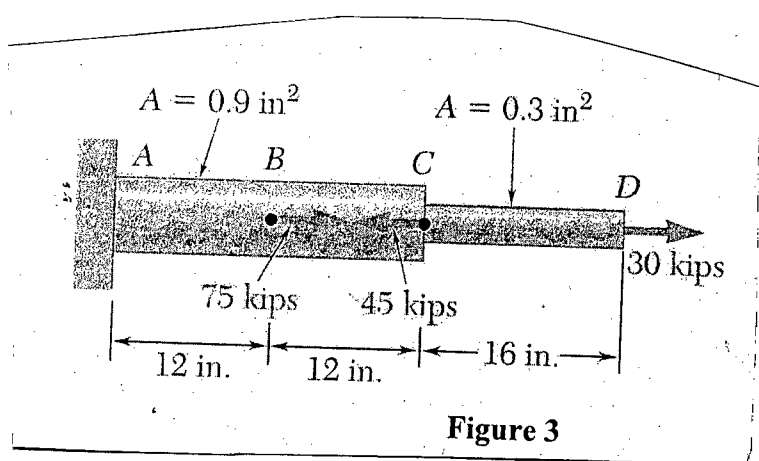

Figure 3

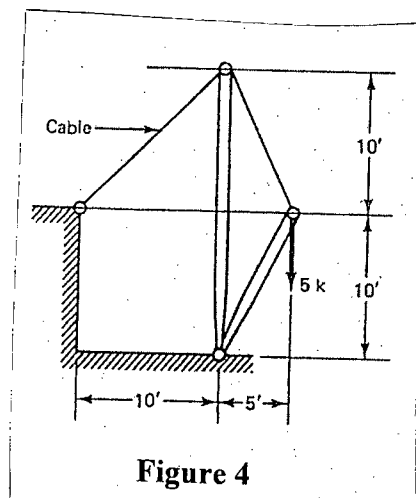

Figure 4

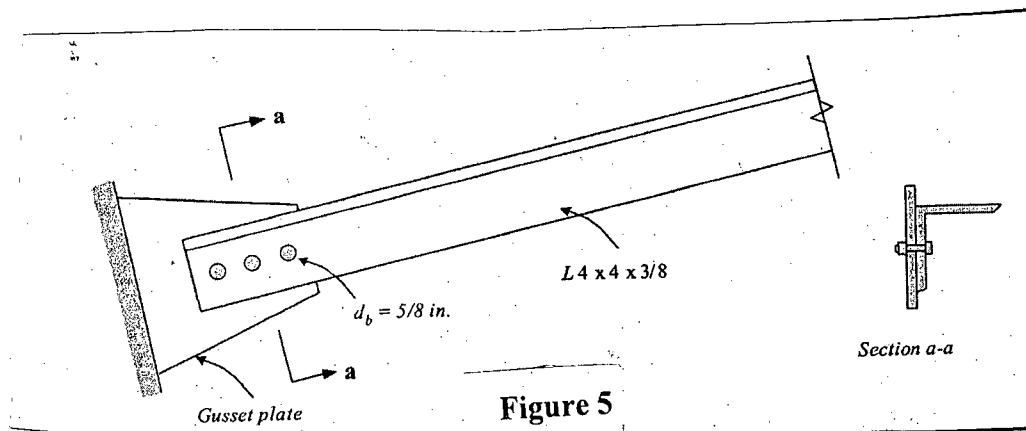

Figure 5

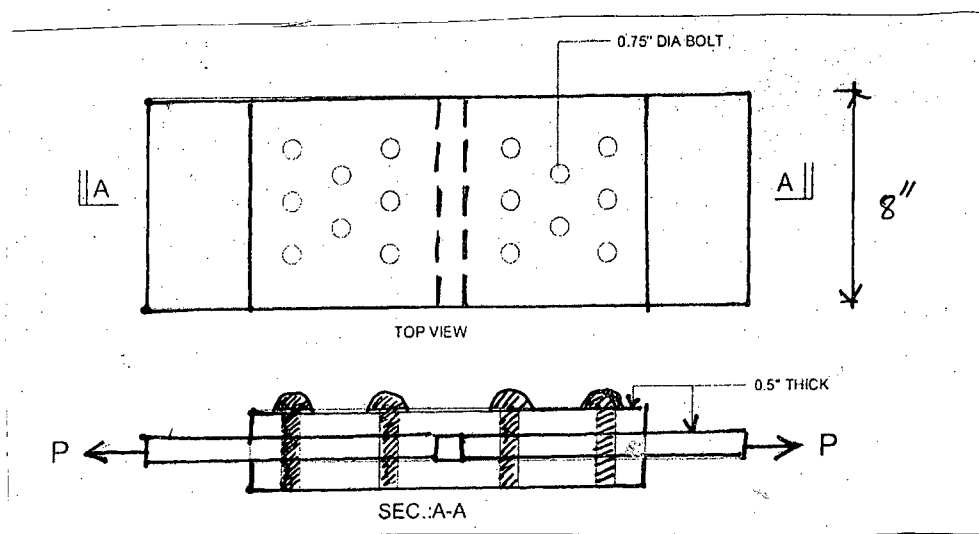
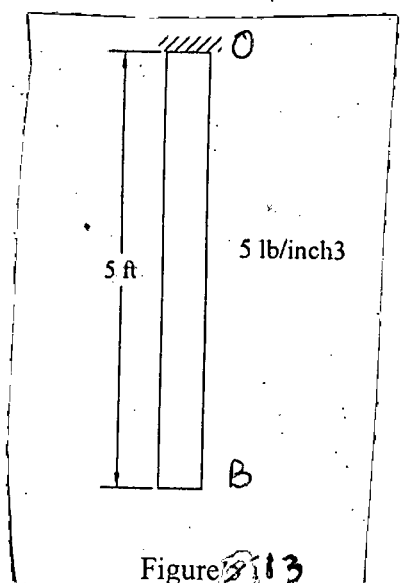
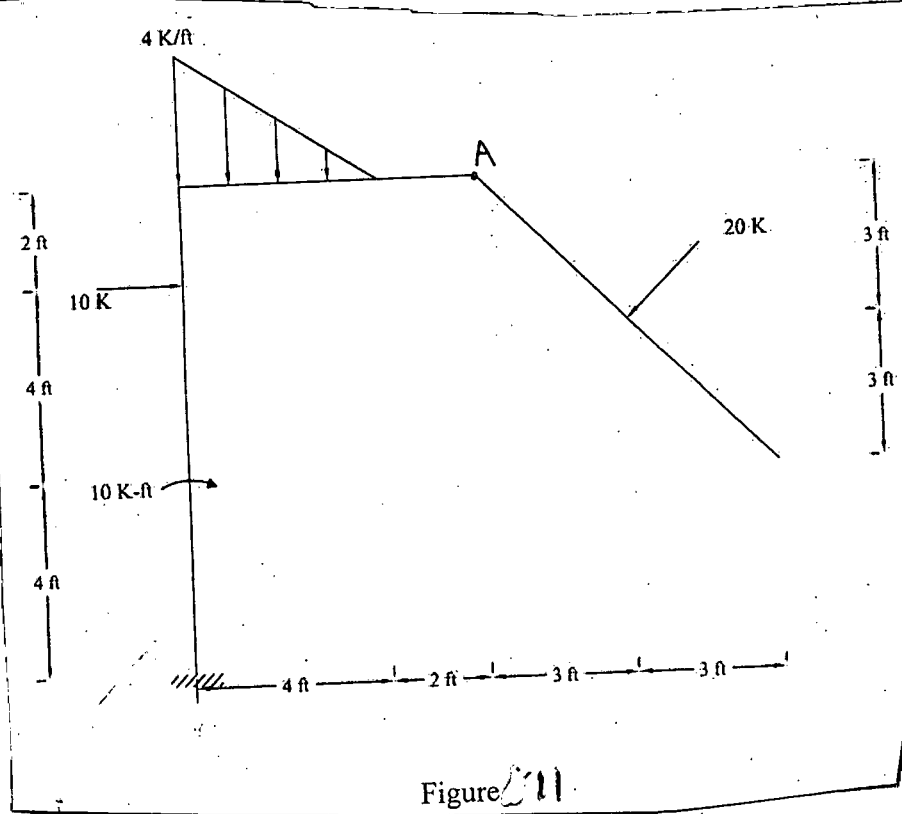
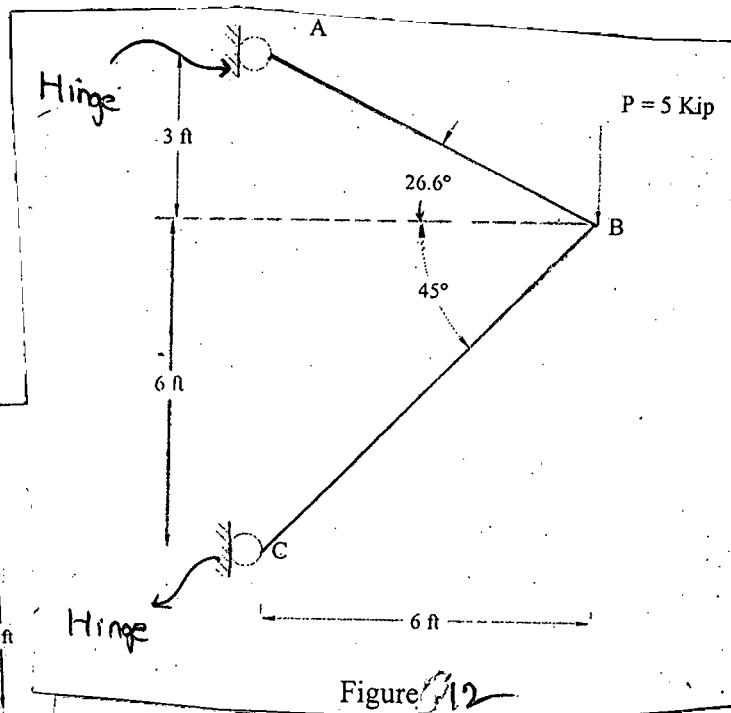
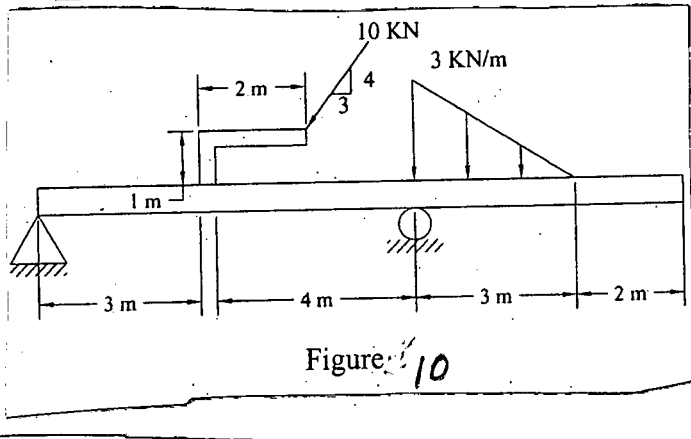
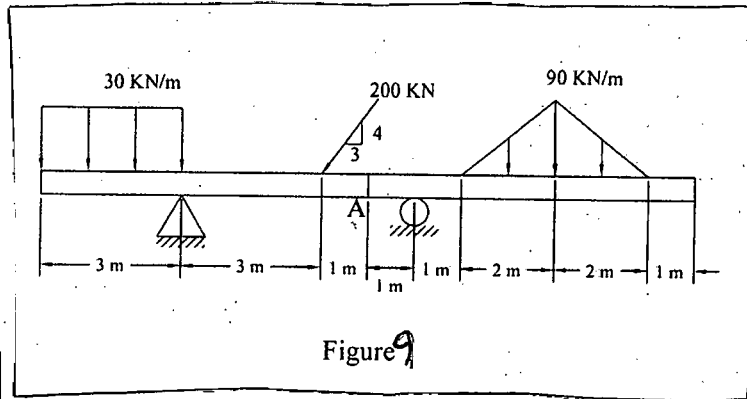
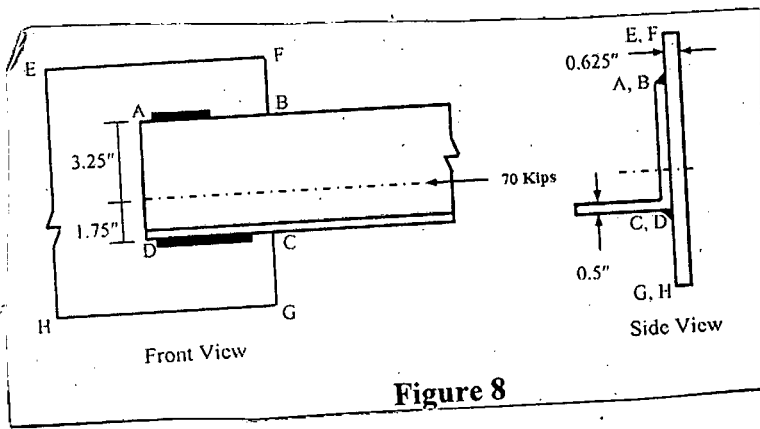
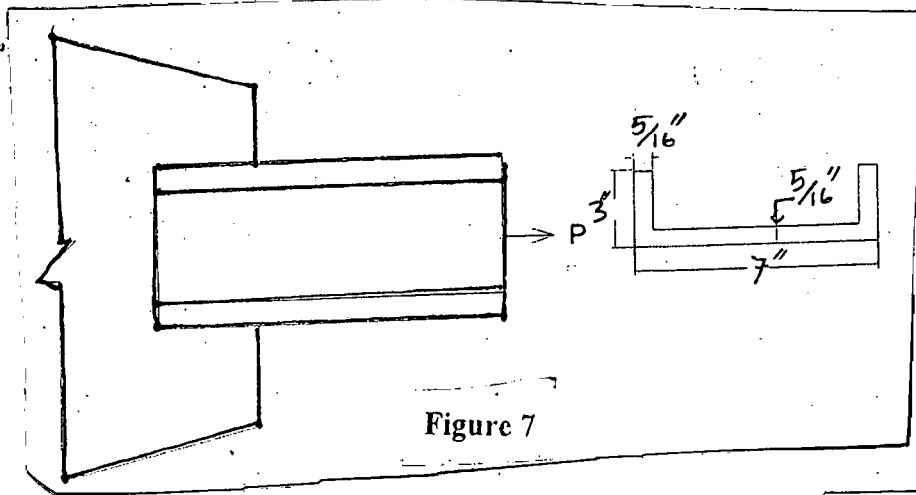

Figure 6



SECTION – A

There are **FOUR** questions in this section. Answer any **THREE**.

1. (a) Discuss the nature of philosophy. (8)
(b) What are the misconceptions about philosophy? Do you agree with them? Provide reasons for your answer. (15 1/3)
2. (a) Discuss different branches of philosophy. (12)
(b) Show that the relation between philosophy and science is not contradictory-rather complementary to each other. (11 1/3)
3. (a) Give a critical exposition of authoritarianism as a source of knowledge. (15 1/3)
(b) How does John Locke refute the innate ideas introduced by Rene Descartes? (8)
4. (a) Explain with examples the distinction between formal truth and material truth. (7)
(b) Explain different theories of truth. Which one is more satisfactory to you and why? (16 1/3)

SECTION – B

There are **FOUR** questions in this section. Answer any **THREE**.

5. (a) Discuss the nature of environmental philosophy. (10)
(b) Do you think that human beings are entitled to dominate nature? Give reasons for your answer. (13 1/3)
6. (a) Explain with examples bribery and extortion. (8)
(b) Why are professional engineers forbidden to receive and offer bribe? (15 1/3)
7. (a) What are the conditions of moral responsibility? (8)
(b) Do you think that the executive of Silver Recovery System were responsible for the death of Mr. Stefan Golab? Give reasons for your answer. (13 1/3)
8. (a) What are the fundamental canons introduced by NSPE (National Society of Professional Engineers)? (10)
(b) Discuss different rules of practice introduced by NSPE (National Society of Professional Engineers). (13 1/3)
