

SECTION – A

There are **FOUR** questions in this section. Answer any **THREE**.

1. (a) Find the relation between energy and momentum of a particle of rest mass m_0 . (10)
 (b) Derive an equation for the relativistic kinetic energy of a body and show that for smaller speed it reduces to the classical expression. (17)
 (c) Find the momentum (in MeV/c) of an electron whose speed is $0.60c$. (8)

2. (a) Discuss Einstein's Photo-electric effect. Draw a schematic diagram of the experimental arrangement of this experiment. (9)
 (b) Show graphically how the stopping potential varies with the frequency and intensity of the incident light. How would you find out the work function graphically in the experiment? (18)
 (c) The work function of tungsten is 4.5 eV. Calculate the speed of the fastest electrons ejected from the tungsten surface when light of energy 5.80 eV shines on the surface. Also calculate the stopping potential. (8)

3. (a) Define binding energy of a nucleus. Sketch the curve of the binding energy per nucleon for the most stable nucleus against the corresponding mass number. What information can you obtain from this curve? (17)
 (b) Show that the density of nuclear matter is independent of mass number. (10)
 (c) $^{16}_8\text{O}$ and $^{18}_8\text{O}$, the two isotopes of oxygen have nuclear masses 15.990523 amu and 17.994768 amu, respectively. Calculate the binding energy per nucleon for the two isotopes. Which one of the two isotopes you expect to be more abundant? Given: (8)
 mass of a proton = 1.007276 amu, mass of a neutron = 1.008665 amu.

4. (a) What do you mean by ultimate stress and actual stress? What are ductile and brittle materials? (10)
 (b) State Hook's law. Sketch the stress-strain diagram. Discuss elaborately about each indicated regions and points of the diagram. (18)

PHY 157/MME

Contd ... Q. No. 4

(c) Calculate the work done in stretching a wire through 0.1×10^{-3} m of a certain material whose area of cross-section is 1×10^{-6} m² and length is 2 m. Young's modulus of the material is 2×10^{11} N/m². (7)

SECTION – B

There are **FOUR** questions in this section. Answer any **THREE**.

5. (a) What do you mean by streamline flow and turbulent flow of liquid? (8)

(b) Write down the equation of continuity, mentioning each term. According to Bernoulli's equation, show with detailed calculation that the pressure energy and kinetic energy are convertible to each other for unit mass of a liquid flowing through a horizontal pipe. (19)

(c) The modulus of rigidity and Poisson's ratio of the material of a wire are 2.87×10^{10} Nm⁻² and 0.379, respectively. Calculate the value of Young's modulus of the material of the wire. (8)

6. (a) How can you compare the coefficient of viscosities of two different liquids using Ostwald's viscometer? Describe in details. (12)

(b) With necessary diagrams, derive an expression for the torsional rigidity of a solid cylinder. (13)

(c) A gas bubble of diameter 2 cm, rises steadily through a solution of density 1.75 gm/cc at the rate of 0.35 cm/sec. Calculate the coefficient of viscosity of the solution. (Neglect the density of the gas) (10)

7. (a) What is a dielectric material? Derive an expression for Gauss law after applying a dielectric inside a parallel plate capacitor. (12)

(b) Find the expressions for charge and current in an RC circuit during charging of a capacitor. What do you understand by capacitive time constant? (15)

(c) An isolated metal sphere whose diameter is 10 cm has a potential of 8000 V. What is the energy density at the surface of the sphere? (8)

PHY 157/MME

8. (a) Define magnetic field vector. If a metal wire of length l carrying a current 'i' is placed at right angles to a uniform magnetic field \vec{B} , show that the force exerted on the wire is given by $\vec{F} = i\vec{l} \times \vec{B}$. (12)

(b) What is the difference between a solenoid and a toroid? Find out the expression for magnetic field vector \vec{B} for a long ideal solenoid. (13)

(c) A solenoid has a mean diameter of 0.05 m and length 2 m. It has layers of 1000 turns each. Calculate the flux density at its centre when a current of 2.5 A flows through it. Also calculate the flux at the centre. (10)

BANGLADESH UNIVERSITY OF ENGINEERING AND TECHNOLOGY, DHAKA

L-1/T-2 B. Sc. Engineering Examinations 2016-2017

Sub : **ME 141** (Engineering Mechanics)

Full Marks : 210

Time : 3 Hours

The figures in the margin indicate full marks.

USE SEPARATE SCRIPTS FOR EACH SECTION

SECTION – AThere are **FOUR** questions in this section. Answer any **THREE**.

1. (a) At the instant shown in Fig. for Q. No. 1(a), cars *A* and *B* are traveling at speeds of 55 mi/h and 40 mi/h, respectively. If *B* is increasing its speed by 1200 mi/h^2 while *A* maintains a constant speed, determine the velocity and acceleration of *B* with respect to *A*. Car *B* moves along a curve having a radius of curvature of 0.5 mile. (17)
- (b) Block *B* moves downward with a constant velocity of 20 mm/s. At $t = 0$, block *A* is moving upward with a constant acceleration, and its velocity is 30 mm/s. Knowing that at $t = 3$ s, slider block *C* has moved 57 mm to the right, determine (i) the velocity of slider block *C* at $t = 0$, (ii) the accelerations of *A* and *C*, (iii) the change in position of block *A* after 5 s. (18)
2. (a) The velocity of block *A* in Fig. for Q. No. 2(a) is 2 m/s to the right at the instant when $r = 0.8$ m and $\theta = 30^\circ$. Neglecting the mass of the pulley and the effect of friction in the pulley and between block *A* and the horizontal surface, determine, at this instant, (i) the tension in the cable, (ii) the acceleration of block *A*, (iii) the acceleration of block *B*. (20)
- (b) The ball in Fig. for Q. No. 2(b) has a mass of 30 kg and a speed $v = 4$ m/s at the instant it is at its lowest point, $\theta = 0^\circ$. Determine the tension in the cord and the rate at which the ball's speed is decreasing at the instant $\theta = 20^\circ$. Neglect the size of the ball. (15)
3. (a) A section of track for a roller coaster consists of two circular arcs *AB* and *CD* joined by a straight portion *BC* (see Fig. for Q. No. 3(a)). The radius of *AB* is 27 m and the radius of *CD* is 72 m. The car and its occupants, of total mass 250 kg, reach Point *A* with practically no velocity and then drop freely along the track. Determine the normal force exerted by the track on the car as the car reaches point *B*. Ignore air resistance and rolling resistance. (18)
- (b) Packages are thrown down an incline at *A* (see Fig. for Q. No. 3(b)) with a velocity of 1 m/s. The packages slide along the surface *ABC* to a conveyor belt which moves with a velocity of 2 m/s. Knowing that $d = 7.5$ m and $\mu_k = 0.25$ between the packages and all surfaces, determine (i) the speed of the package at *C*, (ii) the distance a package will slide on the conveyor belt before it comes to rest relative to the belt. (17)

ME 141/MME

4. (a) Knowing that at the instant shown in Fig for Q. No. 4(a), the velocity of collar D is 1.6 m/s upward, determine (i) the angular velocity of rod AD, (ii) the velocity of Point B, (iii) the velocity of Point A. (18)
- (b) A 20-kg cabinet is mounted on casters as shown in Fig. for Q. No. 4(b). The casters are locked. So, the wheels in the casters do not roll but can slide. The friction co-efficient between the casters-wheel surface and the floor is $\mu_k = 0.25$. If a 100-N force is applied as shown, determine (i) the acceleration of the cabinet, (ii) the range of values of h for which the cabinet will not tip. (17)

SECTION – B

There are **FOUR** questions in this section. Answer any **THREE**.

Symbols have their usual meanings. Assume any missing data.

5. (a) A container of weight, $W = 1165$ N is supported by three cables as shown in Fig. for Q. No. 5(a). Determine the tension in cable AD. (18)
- (b) A vertical load P is applied at end B of rod BC as shown in Fig. for Q. No. 5(b). The constant of spring is k and the spring is unstretched when $\theta = 90^\circ$. Neglecting the weight of the rod, (17)
- (i) Express the angle, θ , in terms of P , k and l .
- (ii) Determine the value of θ when $P = \frac{1}{4}kl$.
6. (a) For the roof truss as shown in Fig. for Q. No. 6(a), determine the force in members CE , DE and DF . (15)
- (b) For the machine element as shown in Fig. for Q. No. 6(b), locate the centre of gravity. (20)
7. (a) For the frame as shown in Fig. for Q. No. 7(a), determine the components of the reactions at B and E if the pulley has a radius of 50 mm. (18)
- (b) As shown in Fig. for Q. No. 7(b), a 40 kg block is attached to link AB and rests on a moving belt. Knowing that $\mu_s = 0.25$ and $\mu_k = 0.20$, determine the magnitude of the horizontal force P that should be applied to the belt to maintain its motion to left. (17)
8. (a) Two 8° wedges of negligible weight are used to move and position the 800 kg block as shown in Fig. for Q. No. 8(a). Knowing that the coefficient of static friction is 0.25 at all surfaces of contact, determine the smallest force that should be applied to the wedge to position the block. (18)
- (b) Determine the moments of inertia of the shaded area as shown in Fig. for Q. No. 8(b) with respect to x axis when $a = 30$ mm. (17)
-

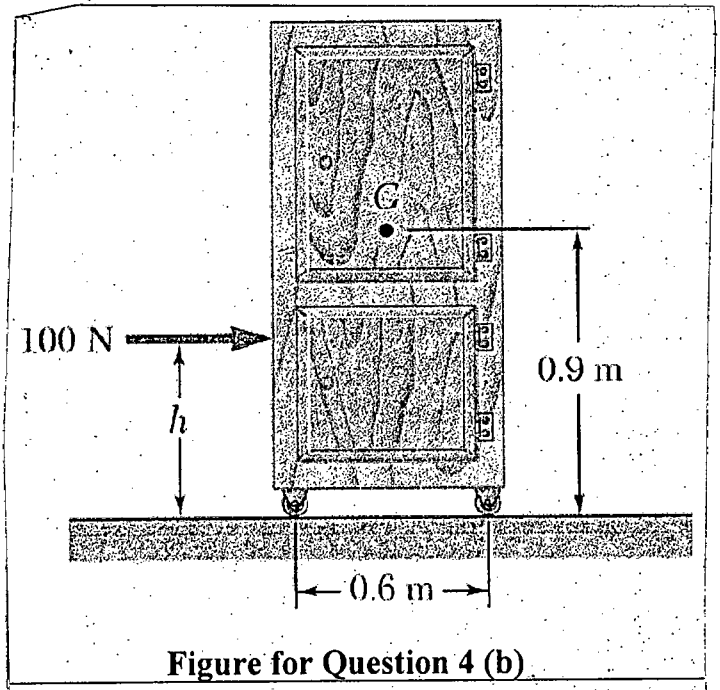
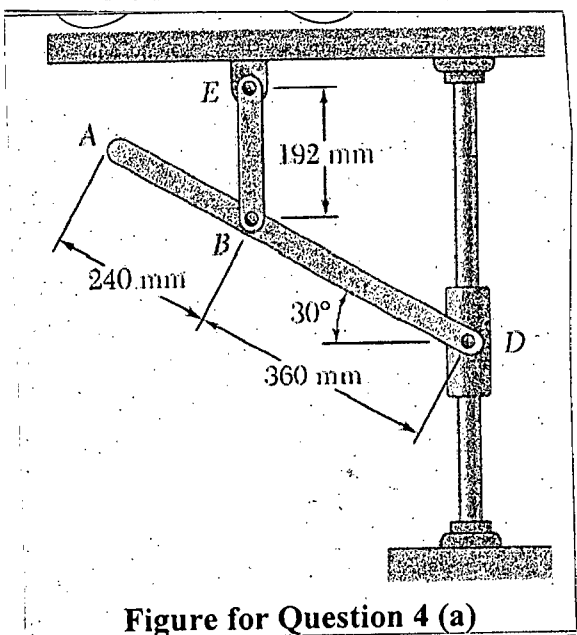
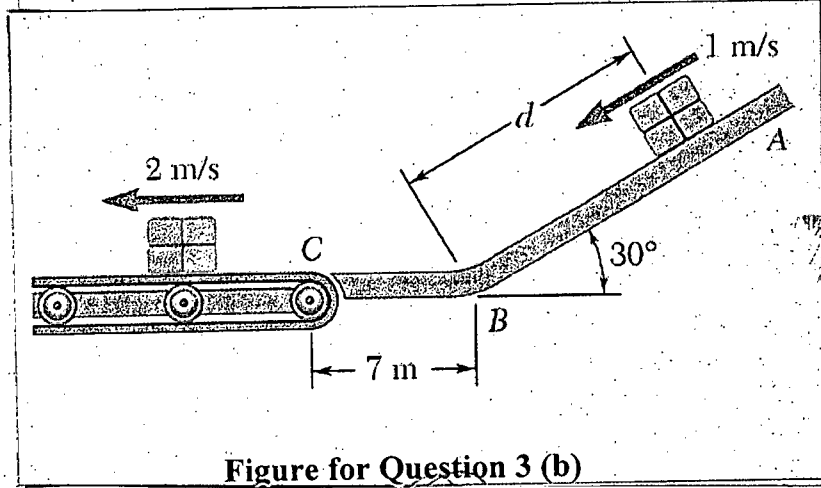
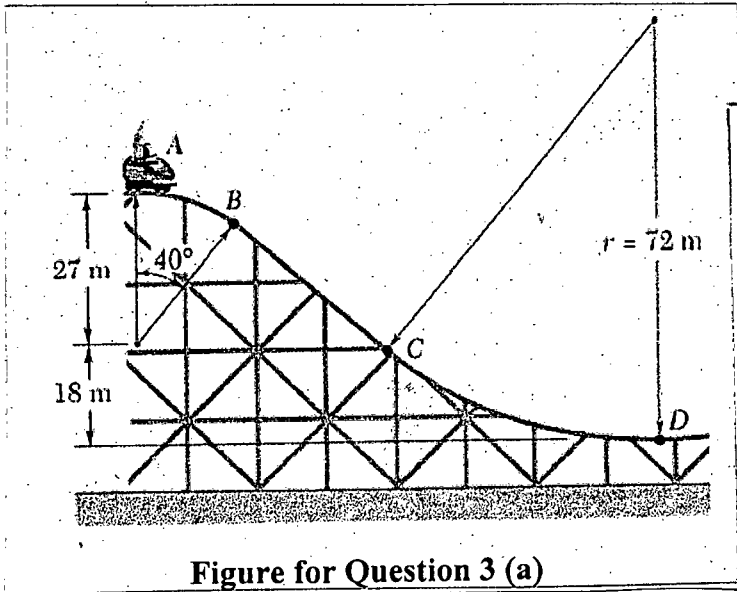
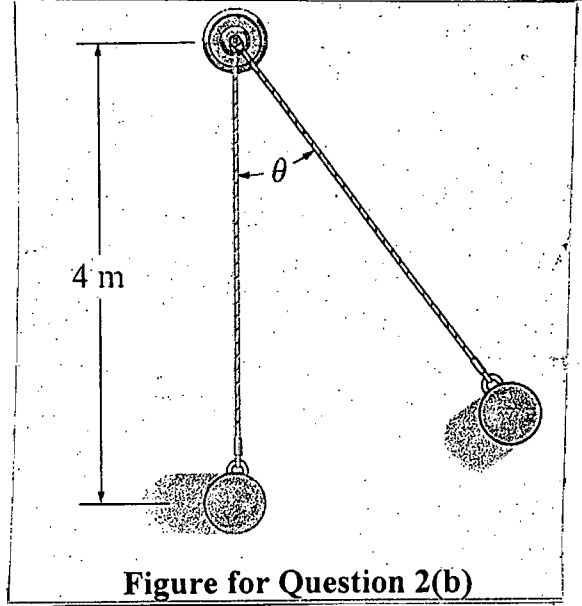
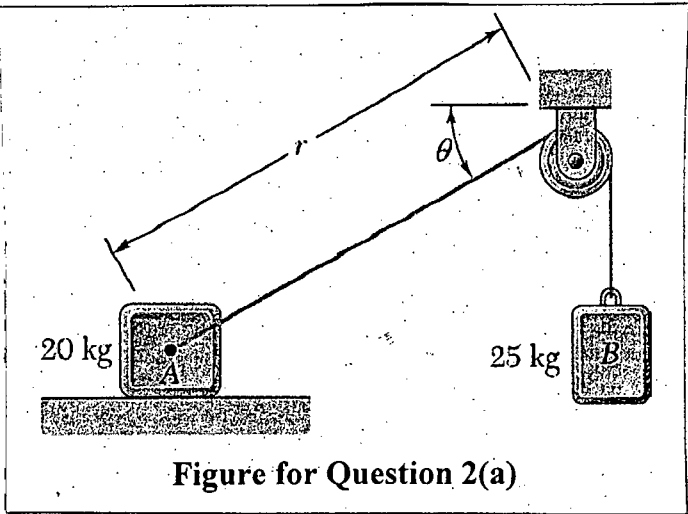
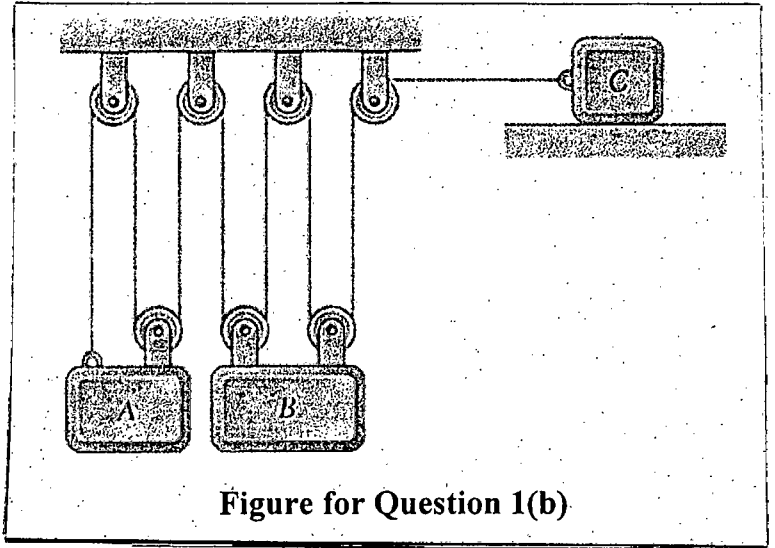
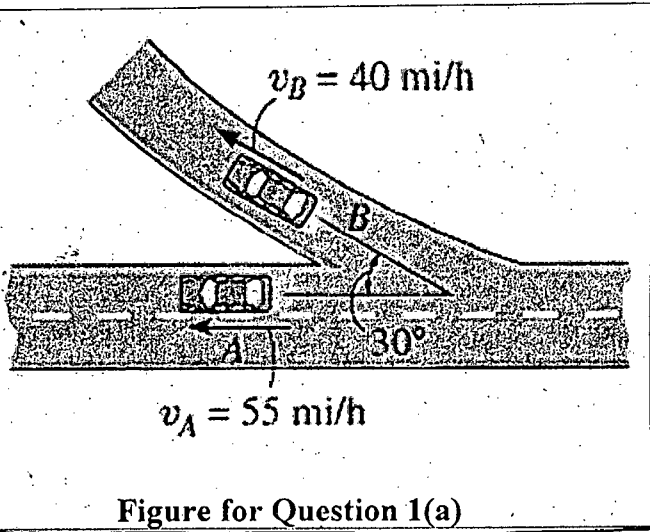

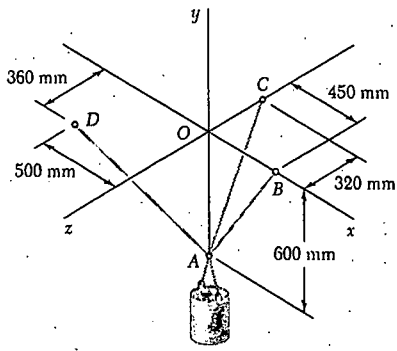

Fig. for Q. 5(a)

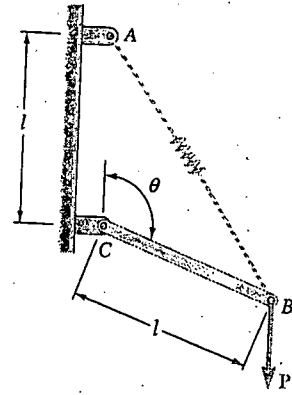

Fig. for Q. 5(b)

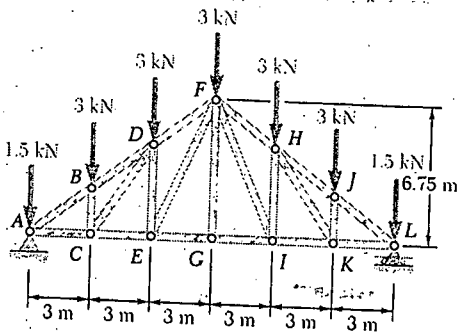

Fig. for Q. 6(a)

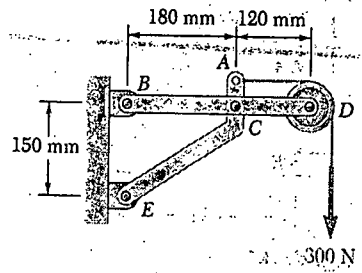

Fig. for Q. 7(a)

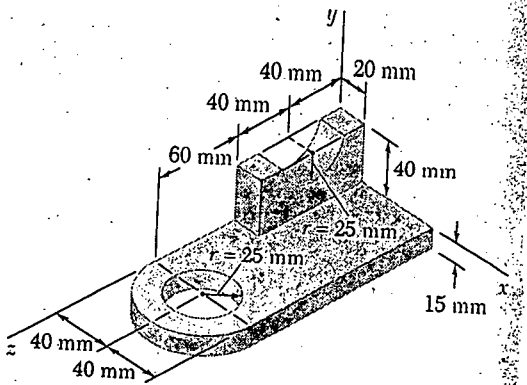

Fig. for Q. 6(b)

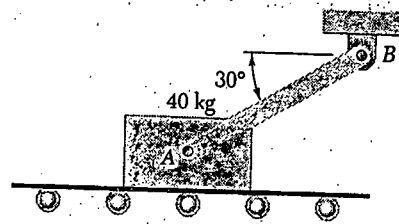

Fig. for Q. 7(b)

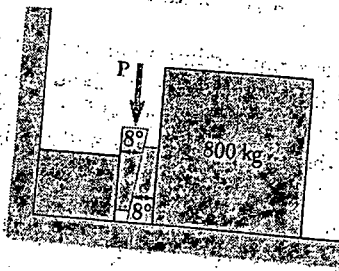

Fig. for Q. 8(a)

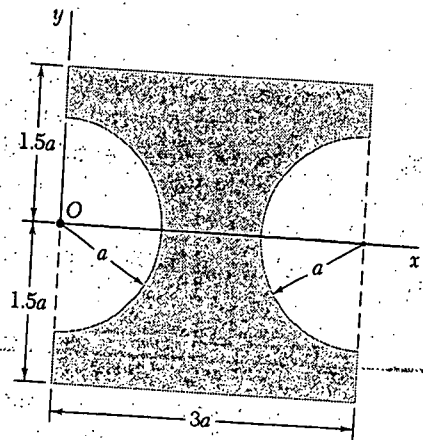

Fig. for Q. 8(b)

L-1/T-2 B. Sc. Engineering Examinations 2016-2017

Sub : **MATH 173** (Vector Analysis and Matrices)

Full Marks : 210

Time : 3 Hours

The figures in the margin indicate full marks.

Symbols have their usual meaning.

USE SEPARATE SCRIPTS FOR EACH SECTION

SECTION – AThere are **FOUR** questions in this Section. Answer any **THREE**.

1. (a) The vertices of quadrilateral are $A(i+2j-k)$, $B(-4i+2j-2k)$, $C(4i+j-5k)$ and $D(i+2j-k)$. At the point A forces of magnitude 2, 3 and 2 gm-wt acting along the line AB, AC and AD respectively, find their resultant. (10)
- (b) Examine whether the vectors $i+2j+3k$, $2i+j+3k$ and $i+j+k$ are linearly independent or dependent. (10)
- (c) Find the equation of the tangent plane and normal to the surface $2xz^2 - 3xy - 4x = 7$ at the point $(1, -1, 2)$. (15)
2. (a) Find the value of n for which the vector $r^n \bar{r}$ solenoidal, where, $\bar{r} = xi + yj + zk$. (11)
- (b) Find the directional derivative of the scalar function $f(x, y, z) = x^2 + xy + z^2$ at the point $A(1, -1, -1)$ in the direction of line AB, where B has co-ordinate $(3, 2, 1)$. (10)
- (c) If $\vec{F} = (\vec{a} \times \vec{r}) r^n$, show that $\text{curl } (\vec{F}) = (n+2)r^n \vec{a} - nr^{n-2} (\vec{a} \cdot \vec{r}) \vec{r}$, where \vec{a} is a constant vector and $\vec{r} = xi + yj + zk$ (14)
3. (a) Find the circulation of \vec{F} round the curve C, where, $\vec{F} = (2x + y^2)i + (3y - 4x)j$ and C is the curve $y = x^2$ from $(0, 0)$ to $(1, 1)$ and $y^2 = x$ from $(1, 1)$ to $(0, 0)$ (15)
- (b) Evaluate $\iint_S \vec{F} \cdot \hat{n} ds$, where $\vec{F} = zi + xj - 3y^2zk$ and S is the surface of the cylinder $x^2 + y^2 = 16$ included in the first octant between $z = 0$ and $z = 5$. (20)

MATH 173/MME

4. (a) Use Green's theorem to evaluate the integral $\oint_C [(x^2 - 2xy)dx + (x^2y + 3)dy]$, where C is the closed curve of the region bounded by $y^2 = 8x$ and $x = 2$. (10)

(b) State Stoke's theorem and verify this theorem for the vector function $\vec{F} = (x+y)i + (2x-z)j + (y+z)k$ taken over the triangle ABC cuts from the plane $3x+2y+z=6$ by the co-ordinate planes. (25)

SECTION - B

There are **FOUR** questions in this Section. Answer any **THREE**.

5. (a) Find the inverse of $\begin{bmatrix} 1 & 2 & 3 \\ 0 & 3 & 2 \\ 1 & 5 & 4 \end{bmatrix}$ by algebraic method. (10)

(b) Find the adjoint of the matrix $A = \begin{bmatrix} 1 & 0 & 2 \\ 1 & 1 & 0 \\ 1 & 2 & 3 \end{bmatrix}$ and then verify $A(adjA) = |A|I$. (12)

(c) Find the solution sets of the following system of linear equations by using Gauss-Jordan elimination. (13)

$$\begin{aligned} x_1 + 2x_2 + x_3 + x_4 &= 6 \\ x_1 - x_2 + x_3 - x_4 &= -2 \\ x_1 + 8x_2 + x_3 + 5x_4 &= 22 \\ 2x_1 + 7x_2 + 2x_3 + 4x_4 &= 20 \end{aligned}$$

6. (a) For the matrix $A = \begin{bmatrix} 1 & 3 & -1 & 3 \\ 3 & 4 & -3 & 4 \\ 1 & 3 & 1 & 2 \end{bmatrix}$, find non-singular matrices P and Q such that

PAQ is in normal form. (13)

(b) Reduce the following matrix into canonical form and hence find it's rank.

$$A = \begin{bmatrix} 3 & 4 & 5 & 6 & 7 \\ 4 & 5 & 6 & 7 & 8 \\ 5 & 6 & 7 & 8 & 9 \\ 10 & 11 & 12 & 13 & 14 \\ 15 & 16 & 17 & 18 & 19 \end{bmatrix} \quad (15)$$

(c) Prove that if A is a square matrix then $A + A^T$ is symmetric and $A - A^T$ is skew symmetric. (7)

MATH 173/MME

7. (a) Find a matrix P that diagonalize A and determine $P^{-1}AP$ where

$$A = \begin{bmatrix} 2 & -1 & 0 & 0 \\ -2 & 3 & 0 & 0 \\ 2 & 0 & 4 & 2 \\ 1 & 3 & -2 & -1 \end{bmatrix} \quad (20)$$

(b) Using Cayley-Hamilton theorem find the inverse of the matrix $A = \begin{bmatrix} 1 & 2 & 2 \\ 3 & 1 & 0 \\ 1 & 1 & 1 \end{bmatrix}$ (15)

8. (a) Reduce the real quadratic form $q = x_1^2 + 2x_2^2 - 2x_3^2 + 4x_1x_2 + 6x_1x_3$ to the canonical form and find the rank, index and signature of the form. (20)

(b) Find the minimal polynomial $m(\lambda)$ of the matrix, $A = \begin{bmatrix} 2 & 1 & 0 & 0 \\ 0 & 2 & 0 & 0 \\ 0 & 0 & 2 & 0 \\ 0 & 0 & 0 & 5 \end{bmatrix}$ (15)

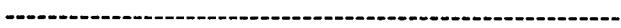

SECTION – A

There are **FOUR** questions in this section. Answers question no 1 and any other **TWO** from the rest.

1. Read the following passage carefully and answer all the questions given below. (45)

It is a great point to enlarge the range of studies which a University professes even for the sake of the students; and though they cannot pursue every subject which is open to them, they will be gainers by living among those and under those who represent the whole circle. This I conceive to be the advantage of a seat of universal learning, considered as a place of education. An assemblage of learned men, zealous for their own sciences, and rivals of each other, are brought, by familiar intercourse and for the sake of intellectual peace, to adjust together the claims and relations of their respective subjects of investigation. They learn to respect, to consult, and to aid each other. Thus is created a pure and clear atmosphere of thought, which the student also breathes, though in his own case he only pursues a few sciences out of the multitude. He profits by an intellectual tradition, which is independent of particular teachers, which guides him in his choice of subjects and duly interprets for him those which he chooses. He apprehends the great outlines of knowledge, the principles on which it rests, the scale of its parts, its lights and its shades, its great points and its little subtleties as he otherwise cannot apprehend them. Hence his education is called "Liberals". A habit of mind is formed which lasts through life, of which the attributes, are freedom, equitableness, calmness, moderation, and wisdom; or which are termed as philosophical habits. This then I would assign as the special fruit of the education furnished at a University, as contrasted with other places of learning on models of teaching. This is the main purpose of a University in its treatment of its students.

Questions:

- (a) How does a University offer an overall gain to students?
- (b) How does an intellectual peace develop?
- (c) How does a student learn to promote an interaction between different fields of knowledge?
- (d) What is 'Liberal' education? What is its impact on students?
- (e) How is a University different from other places of learning?
- (f) Give the meanings of the following words as used in the passage: professes, conceive, assemblage, multitude, apprehends.

HUM 101

2. (a) Discuss in brief the principles of writing a business letter. (10)
(b) You have received some products in a damaged condition from your suppliers. Write a letter of complaint emphasizing the need of greater care in complying with the orders. (10)
(c) Write the phonetic transcription of the following words: (any Five) (10)
Among, colonel, decade, flame, exact, father.
3. (a) Write in brief the components of "Back Matter" in a Report. (10)
(b) Write a short essay on any ONE of the following topics: (10)
(i) The Glamour of the Past
(ii) Environmental Disasters
(iii) Online Education.
(c) Write a dialogue between a teacher and student about the latter's availing a scholarship abroad. (10)
4. (a) Transform the following sentences as directed. (Any Five) (10)
(i) If I make a promise, I keep it. (Make it simple)
(ii) Unless you do it I shall fine you. (Compound)
(iii) I am glad that you have passed the exam. (Simple)
(iv) What he has said is true. (Simple)
(v) A relationship needs to be tended to like a plant. (Compound)
(vi) Spare the rod and spoil the child. (Complex)
(b) What are the different parts of formal report? (05)
(c) Write short notes on any three of the following: (15)
(i) Diphthongs
(ii) Annual Confidential Report
(iii) Terminator in a paragraph
(iv) Barriers to communication.

SECTION-B

There are **FOUR** questions in this section. Answers question no **5** and any other **2(TWO)** from the rest.

Symbols indicate their usual meaning.

5. (a) Explain with reference to the context any two of the following: (15)
(i) "I thought I had the blood of a man on his hands all these years."
(ii) "We want to be rescued; and of course we shall be rescued."
(iii) "There must be more money! there must be more money."

HUM 101

Contd... Q. No. 5

- (b) Answer any one of the following: (15)
- (i) Discuss the role of fate in a man's life. Provide evidence in favour of your view from the story 'An Astrologer's Day'.
 - (ii) In 'Shooting an Elephant,' why does Orwell act against his better judgement?
- (c) Answer any three of the following: (15)
- (i) What sort of rules does Ralph establish for the assembly?
 - (ii) What is the climax of the story 'Shooting an Elephant'?
 - (iii) What impression do you get about the officer, the crowd and the elephant from your study of 'Shooting an Elephant'?
 - (iv) What ironic elements do you find in 'An Astrologer's Day'?
 - (v) From the point of view of Paul's mother, what is the main problem of the family?
6. (a) Recast and correct any ten of the following sentences: (15)
- (i) They made less mistakes with the new calculating machine.
 - (ii) The number of books was more adequate than we had expected.
 - (iii) Mr. Philips, together with some friends and neighbours, are planning a celebration.
 - (iv) The jury is arguing among itself.
 - (v) It is you who is next.
 - (vi) This is the case what I want.
 - (vii) Who did you give the book to?
 - (viii) That was me whom you saw yesterday.
 - (ix) Abraham Lincoln was one of the great man in American history.
 - (x) He decided to work slow and easy.
 - (xi) They can't hardly speak English.
 - (xii) He had a need and interest in athletics.
- (b) Give meanings of and make sentences with any ten of the following words: (15)
- Admonish, blandishment, cataclysm, eloquence, flounder, germinate, homage, intrepid, nadir, placate, ramble, surfeit.
7. Amplify any one of the following: (30)
- (i) To a good man, whether alive or dead, no evil can happen.
 - (ii) Fortune favoures the brave.
8. Write a précis of the following passage with a suitable title: (30)

HUM 101

Contd... Q. No. 8

In all history, nothing is so surprising or so difficult to account for as the sudden rise of civilization in Greece. Much of what makes civilization had already existed for thousands of years in Egypt and in Mesopotamia, and had spread thence to neighbouring countries. But certain elements had been lacking until the Greeks supplied them. What they achieved in art and literature is familiar to everybody, but what they did in the purely intellectual realm is even more exceptional. They invented mathematics and science and philosophy; they first wrote history as opposed to mere records; they speculated freely about nature of the world and the ends of life, without being bound in the chains of any inherited orthodoxy. What occurred was so astonishing that, until very recent times, men were content to gaze and talk mystically about the Greek genius. It is possible, however, to understand the development of Greece in scientific terms, and it is well worth to do so. Philosophy begins with Thales, who fortunately, can be dated by the fact that he predicted an eclipse which, according to the astronomer occurred in the year 585 B. C. Philosophy and science — which were originally separate — were therefore born together at the beginning of the sixth century. What had been happening in Greece and neighbouring countries before this time? Any answer must be in part hypothetical, but archeology, during the present century, has given us much more knowledge than was possessed by our grandfathers.

SECTION - A

There are **FOUR** questions in this section. Answer any **THREE**.

- Define conformation. Explain the stability of different conformers of n-butane. (10)
 - Explain Baeyer strain theory. Why cyclodecane is less stable than Cyclopropane? (10)
 - Give the mechanism of chlorination of ethane under diffuse sunlight. (5)
 - Relative reactivity of hydrogen for chlorination $H: 3^\circ : 2^\circ : 1^\circ = 5.0 : 3.8 : 1.0$, measure the percentage yield of the product for the reaction of chlorine and n-butane. (10)
- Why is alkene more reactive than alkane? Explain with hybridization of alkene. (6)
 - What are isomers? Explain the E – and Z – isomers with examples. (8)
 - Why a cis-alkene is more polar than trans-alkene? Explain with example. (5)
 - Give the mechanism for the addition of Bromine to cyclopentene. (6)
 - Explain the following reaction with example (5×2=10)
 - Oxymercuration reaction
 - Hydroboration reaction.
- Show the mechanism of chlorination of alkyne. (6)
 - How can you prepare ketone from alkyne? Give example. (6)
 - Identify stereogenic center and explain the enantiomer and diastereomer for the compound, $CH_3CH_2CH(Cl)CH(OH)CH_2CH_3$. (8)
 - Identify the R-and S-configuration for following compounds: (2×4=8)

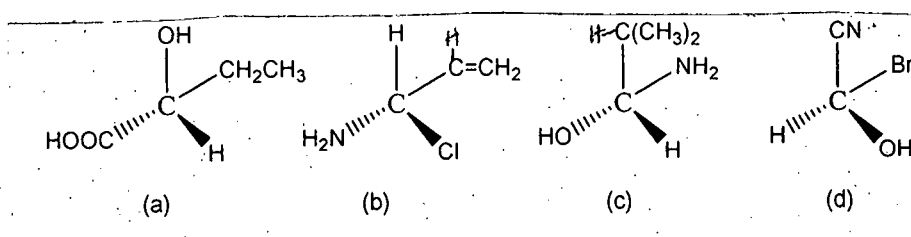

CHEM 121/MME

Contd ... Q. No. 3

- (e) Draw all possible stereoisomers, then pair up enantiomers and diastereomers of 3-methyl-cyclopentanol. (7)

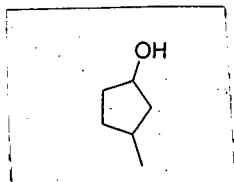

4. (a) Discuss the order of basicity and leaving capacity of the elements across the rows and columns of the periodic table. (8)
- (b) How can you prepare hexylamine from bromo-pentane? Show mechanisms. (6)
- (c) What is the effect of strong and weak nucleophile on nucleophilic substitution reaction? (5)
- (d) Discuss the chirality of amines. How can you prepare methylamine from ammonia? (7)
- (e) What is deductive amination? Prepare tertiary amine through reductive amination method. (9)

SECTION – B

There are **FOUR** questions in this section. Answer any **THREE**.

5. (a) What are heterocyclic compounds? Give classification of heterocyclic compounds with examples. (3+7=10)
- (b) Show that pyrrole is not only basic but also acidic in nature. (6)
- (c) How would you carry out the following conversions? (5×3=15)
- (i) 2, 5, - Dihydropyrrole from pyrrole
 - (ii) 2- Chloromercurifuran from furan
 - (iii) 2, 3, 4, 5 – Tetrachloropyrrole from pyrrole.
 - (iv) Pyrrole – 2 – carboxylic acid from pyrrole.
 - (v) 2-Iodothiophene from thiophene
- (d) How furfural undergoes Benzoin condensation reaction? (4)

CHEM 121/MME

6. (a) Describe the Bischler-Napieralski synthesis of isoquinoline and a commercial methods of synthesis of indigo. (10)
- (b) How the structural elucidation of indigo was carried out. (10)
- (c) Show the position of electrophilic substitution of quinoline with examples. (9)
- (d) What happen when quinoline is subjected to mild and catalytic hydrogenation? (6)
7. (a) Show the general mechanism of electrophilic substitution of benzene with examples. (12)
- (b) Explain with mechanism the Fridel-Craft's alkylation reaction and mention its limitations. (10)
- (c) What happen when benzene is treated with the following: (3×3=9)
- (i) Chlorine in presence of sunlight
- (ii) Carbonmonoxide and HCl in presence of AlCl₃ at 100 atm.
- (iii) Air in presence of V₂O₅ at 450°C
- (d) With reference to aromatic disubstitution, explain the term ortho-para directors. (4)
8. (a) Mention the various methods for the detection of alkaloids in plant extract. (7)
- (b) Describe how the nature of oxygen groups can be identified in the structure of alkaloids. (10)
- (c) Apply Hofmann's method of exhaustive methylation for conversion of reduced pyridine into 1, 3 – pentadiene. (9)
- (d) Briefly discuss how the structure of coniine was established. (9)
-