

**SECTION – A**

There are **FOUR** questions in this section. Answer any **THREE**.

1. (a) Distinguish between crystalline and amorphous solids. (7)
- (b) What is a unit cell? Describe the unit cell of sodium chloride (NaCl) structure. Show that the packing fraction for face centered cubic (FCC) lattice is about 0.74. (18)
- (c) Copper has FCC structure and its atomic radius is 1.278 Å. Calculate its density. Atomic weight of copper is 63.54 amu. (10)
  
2. (a) Write a short notes on: (10)
  - (i) Ionic bonds
  - (ii) Van der Waal's bonds
- (b) What are Miller indices? Show that in a crystal of cubic structure, the distance between the planes with Miller indices h, k, l is equal to  $d = \frac{a}{\sqrt{h^2 + k^2 + l^2}}$ , where a is the length of the cube edge. (15)
- (c) Lead is face centered cubic with an atomic radius of  $r = 1.746 \text{ \AA}$ . Find the spacing of (i) (200) planes (ii) (220) planes and (iii) (111) planes. (10)
  
3. (a) What is meant by crystal defects? Briefly discuss point defects in a crystal. (7)
- (b) Explain the formation of a stable bond using the potential energy versus interatomic distance curve. Derive an expression for binding energy for an ionic crystal and hence obtain the expression for the Madelung constant. (20)
- (c) Distinguish among conductor, insulator and semi-conductor. (8)
  
4. (a) Briefly explain the relativity of simultaneity. (9)
- (b) Deduce Lorentz transformation equations. (18)
- (c) An electron is accelerates upto a kinetic energy of  $5 \times 10^6 \text{ eV}$ . Calculate its velocity. (8)

**PHY 153/WRE**

**SECTION – B**

There are **FOUR** questions in this section. Answer any **THREE**.

5. (a) What are the failures of wave theory of light to explain photo-electric effect. (5)

(b) Show that the change in wavelength of a photon during Compton scattering is proportional to  $\sin^2\left(\frac{\theta}{2}\right)$ . (18)

(c) If the maximum kinetic energy of the recoil electron in a Compton scattering experiment is 10 KeV. What is the wavelength of the incident photon? (12)

6. (a) Briefly describe the origin of the nuclear force. (10)

(b) What do you understand by the “liquid drop model” of the nucleus? Derive an expression for the semi-empirical mass formula with volume energy, surface energy and coulomb energy. (18)

(c) A reactor is developing energy at the rate of 32 MW. How many atoms of  ${}_{92}\text{U}^{235}$  undergo fission per second? Given that energy released per fission of  ${}_{92}\text{U}^{235}$  is 200 MeV. (7)

7. (a) Define electric flux. State Gauss’s theorem in electrostatics. What is a Gaussian surface? (8)

(b) Deduce Coulomb’s law from Gauss’s law. (6)

(c) Applying Gauss’s law show that electric field at a point due to an infinite line of charge with uniform charge density  $\lambda$  is  $E = \frac{\lambda}{2\pi\epsilon_0 r}$ . (12)

where ‘r’ is the perpendicular distance from the line of charge to the point.

(d) A charge of  $17.7 \times 10^{-4}$  C is distributed uniformly over a large sheet of area  $200 \text{ m}^2$ . Calculate the electric field intensity at a distance of 20 cm from it in air. (9)

8. (a) What are dielectrics? Distinguish between polar and non-polar dielectrics. Give examples. (8)

(b) Write down the definitions of current density and drift velocity of an electron. Show the relation  $\vec{J} = -nqV_d$  where the symbols have their usual meanings. (8)

(c) Show that the frequency of the circular motion of a charged particle moving in a uniform magnetic field  $\vec{B}$  is  $f = \frac{qB}{2\pi m}$  where the symbols have their usual meanings. (12)

(d) A wire of length 0.80 m carrying a current of 2.75 A, placed perpendicular to a uniform magnetic field, experiences a force of 2.85 N. What is the magnitude of the magnetic field where the wire is located? (7)

-----

---

**SECTION – A**

There are **FOUR** questions in this section. Answer any **THREE**.

1. (a) What does an aggregate demand curve look like? Explain the shape of an aggregate supply curve. (10)
- (b) What is meant by inflation? What are the causes of demand pull and cost push inflation? (10)
- (c) Why is demand pull inflation better than cost push inflation? (5)
- (d) How will you determine macroeconomic equilibrium with the help of aggregate demand and aggregate supply? (10)
  
2. (a) Explain the concepts of gross national product (GNP), gross domestic product (GDP) net national product (NNP). (5)
- (b) Make a comparative discussion between microeconomics and macroeconomics. (5)
- (c) Briefly discuss the general and special difficulties in the measurement of national income of a developing country like Bangladesh. (10)
- (d) Calculate national income from the following information: (15)  

GNP = Tk. 1,25,000 crore  
Depreciation = Tk. 10,500 crore  
Indirect tax = 11,000 crore  
Subsidy is 20% of indirect tax.
  
3. (a) Narrate the stages of growth given by Professor Rostow. (15)
- (b) What is meant by investment? Briefly discuss the criteria for making an investment decision. (20)

**HUM 177/URP**

4. (a) Define money (5)
- (b) What are the functions of money? Discuss. (15)
- (c) Illustrate the relationship between inflation and unemployment using “Philip’s curve” and its implications. (15)

**SECTION – B**

There are **FOUR** questions in this section. Answer any **THREE**.

5. (a) Draw a graph of linear consumption function and explain it. (5)
- (b) Describe the three Keynes’s Conjectures about the consumption function. (15)
- (c) Discuss Milton Friedman’s Permanent- Income Hypothesis. (15)
6. (a) Define nominal and real exchange rate. Give example of nominal and real exchange rate and show the relationship between them. (10)
- (b) What will be the impact of trade (export-import) if real exchange rate increases and why? (15)
- (c) Explain the “Quantity Theory” of money. (10)
7. (a) Derive the IS curve using Keynesian Cross. (15)
- (b) Derive the LM curve from Liquidity Preference. (15)
- (c) What is government purchase multiplier? Suppose,  $MPC = 0.7$ . Find the value of the government purchases multiplier. (5)
8. (a) What determines whether a country imports or exports a good? Illustrate using “Comparative Advantage Theory”. (20)
- (b) How Free Trade Affects Welfare in an Exporting Country? (10)
- (c) Will an economy loose if it imports commodity or services from another country? (5)

**SECTION – A**

There are **FOUR** questions in this Section. Answer any **THREE**.

1. (a) Enlist different types of survey stations and survey lines and show them in figure. A surveyor aims to survey a land of Gazipur. At the commencement of his work he identified that the objects are located approximately 20 ft from the main chain line. What type of offset measurements should be taken in this case? Justify your answer. (7+5=12)

(b) A base line was measured by a tape suspended in catenary under a pull of 145 N, the mean temperature being 14°C. The lengths of various segments of the tape and the difference in level of the two ends of a segment are given below:

Bay/Span	Length (m)	Difference in level (m)
1	29.988	+0.346
2	29.895	-0.214
3	29.838	+0.309
4	29.910	-0.106

If the tape was standardized on the flat under a pull of 95 N at 18°C. Determine the correct length of the line. Take (16 $\frac{2}{3}$ )

Cross sectional area of the tape = 3.35 mm<sup>2</sup>

Mass of the tape = 0.025 kg/m

Coefficient of linear expansion =  $0.9 \times 10^{-6}$  per °C

Young's modulus =  $14.8 \times 10^4$  MN/m<sup>2</sup>

Mean height of the line above M.S.L. = 51.76 m

Radius of earth = 6370 km

(c) A big pond obstructs the chain line AB (see fig. 1). A line AL = 2000 m was measured on the left of line AB for circumventing the obstacle. Similarly, another line AM was measured on the right of the line AB whose length was 1800 m. Points M, B, L are on the same straight line. Lengths of lines BL and BM are 1600 m and 1400 m respectively. If the chainage at A is 1264.44 m, find the distance AB and the chainage of B. (10)

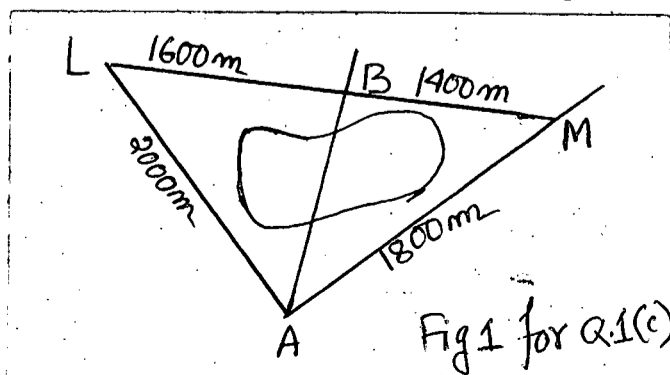

**WRE 103**

**Contd ... Q. No. 1**

(d) Explain salient features of dumpy and wye level. (8)

2. (a) State the components of a traverse chart. What are the usefulness of anallactic lens in tacheometric survey: (6+3=9)

(b) Differentiate between: (3×4=12)

- (i) True bearing and magnetic bearing
- (ii) Independent and consecutive coordinate
- (iii) Control interval and Horizontal equivalent
- (iv) Direct and Indirect method of contouring

(c) Calculate the area of the following traverse. (Table-1) (25<sup>2</sup>/3)

Side	WCB	Length (ft)
AB	342°48'	287
BC	36°15'30"	260
CD	83°21'00"	220
DE	148°53'40"	280
EF	204°28'30"	320
FG	274°28'30"	300

3. (a) Derive the distance and elevation formula for inclined sights with staff remain normal, provided that the ground point has a vertical elevation angle. (15)

(b) Two sets of tachometric readings were taken from an instrument station A, the reduced level of which was 100.06 m to a staff station B (Table-2) (15)

- (i) Instrument P-multiplying constant 100, additive constant 0.06, staff held vertical
- (ii) Instrument P-multiplying constant 90, additive constant 0.06, staff held normal

What should be the stadia reading with instrument Q?

Instrument	At	To	HI (m)	Vertical angle	Stadia readings (m)
P	A	B	1.5	26°	0.755, 1.005, 1.255
Q	A	B	1.45	26°	?

Table 2 for Q. 3(b)

(c) In a proposed hydro electric project a storage was required to provide a storage of 9.0 million between lowest drawdown (L.D.D) and top WL(T.WL). The area contained within the stated contours a upstream face of the dam were as follows: (16<sup>2</sup>/3)

Contour (m)	200	195	190	185	180	175	170	165
Area (ha)	60	50	46	34	30	26	14	9

If L.D.D was to be 168 m calculate the T.W.L for 70% full storage capacity.

**WRE 103**

4. (a) The following consecutive readings were taken with a level and 5 metre leveling staff on continuously sloping ground at a common interval of 20 m. The reduced level of the first point was 208.125 m. Rule out a page of a level field book and enter the above readings. Calculate the reduced levels of the points by rise and fall method and also the gradient of the line joining first and last point. (Table 3) (10)

Station	B.S	I.S	F.S	R.L (m)
1	0.385			208.125
2		1.030		
3		1.925		
4		2.825		
5		3.730		
6	0.625		4.685	
7		2.005		
8		3.110		

Table 3 for Q. 4(a)

(b) In order to determine the elevation of top Q of a signal on a hill, observations were made from two stations P and R. P, R and Q were on the same plane. If the angles of elevation of the top Q of the signal measured at P and R were 25°35' and 15°05' respectively. Determine the elevation of the foot of the signal if the height of the signal above its base was 4 m. The staff readings upon the bench mark (105.42 m) were respectively 2.755 m and 3.855 m when the instrument was at P and at R. The distance between P and R was 120 m. (14<sup>2</sup>/<sub>3</sub>)

(c) What are the requirements of remote sensing? Briefly explain the uses of GPS and GPRS. (10)

(d) What are the functions of total station? Write down the advantage and disadvantages of total station. (6+6=12)

**SECTION - B**

There are **FOUR** questions in this Section. Answer any **THREE**.

5. (a) Discuss the objectives and basic methodology of "Shoreline Survey". (5)

(b) Briefly discuss the devices available for measurement of stage with sketch and also write the operational principle. (16)

(c) The followings are data obtained in a stream gauging operation in a river. Compute the discharge. (18<sup>2</sup>/<sub>3</sub>)

Distance from right bank (m)	Depth, d (m)	Velocity		
		at 0.20d	at 0.6d	at 0.8d
0.0	0.0	0.0	0.0	0.0
1.5	1.3	0.6	0.45	0.4
3.0	2.5	0.9	0.7	0.6
4.5	1.7	0.7	0.59	0.5
6.0	1.0	0.6	0.53	0.4
7.5	0.4	0.4	0.35	0.3
9.0	0.0	0.0	0.0	0.0

**WRE 103**

**Contd ... Q. No. 5**

(d) Discuss the advantages and limitations of ultrasonic method for discharge measurement. (7)

6. (a) Define the arc and chord definition of the degree of a curve. Differentiate between the linear and angular method for ranging a circular curve. (5+6=11)

(b) What are the uses and advantages of transition curve? State the characteristics of an ideal easement curve. (6+7=13)

(c) Calculate the offsets to set out a vertical curve (full length of the curve) which connects an upgrade of 1% and downgrade of 0.5%. Chainage at the point of intersection is 600 m and the R. L at the point of intersection is 65 m. Take the rate of change of grade as 0.1% per chain of 30 m length. Take the interval as 30 m for calculation of offsets. (22<sup>2</sup>/<sub>3</sub>)

7. (a) Write short note on : (i) Ground control and (b) Scale of a vertical photograph. (8)

(b) Differentiate between the followings: (i) Overlap and side lap, (ii) Crabbing and Drifting, and (iii) Eccentric and side camera station. (4+4+4=12)

(c) An area 80 km long in the north-south direction and 60 km in the east west direction is to be photographed with a lens having 21 cm focal length for the purpose of compiling a topographic map. The size of photograph is 18 cm × 18 cm. The average scale is to be 1:20000 at an average ground surface elevation of 400 m above mean sea level. Overlap is to be at least 50% and side lap is to be 15%. The ground speed of the aircraft will be maintained as 300 km/hr. Determine (i) No. of flights required (ii) Actual ground distance between flight lines (iii) Exposure interval (iv) Total number of photographs. (18<sup>2</sup>/<sub>3</sub>)

(d) Discuss the working principle of “electromagnetic method of discharge measurement” with necessary sketch. (8)

8. (a) Differentiate between the latitude and longitude with sketch. Write short note on “Area computation from map measurements”. (8+8=16)

(b) The following perpendicular offsets were taken from a chain line to a hedge

Chainage (m)	0	15	30	60	90	100	120
Offset (m)	7.6	8.0	10.1	12.0	7.5	7.9	6.4

Calculate the area between the survey line, the hedge and the end offsets using trapezoidal rule and Simpson’s rule. Comment on the difference of the results obtain from these two methods. (14)

(c) A railway embankment 400 m long is 12 m wide at the formation level and has the side slope 2 to 1. The ground levels at every 100 m along the center line are as follows: (16<sup>2</sup>/<sub>3</sub>)



= 5 =

Distance (m)	0	100	200	300	400
R.L. (m)	204.8	206.2	207.5	207.2	208.3

The formation level at zero chainage is 207.00 m and the embankment has a rising gradient of 1 in 100. The ground is level across the center line. Calculate the volume of earthwork.

-----

**SECTION – A**

There are **FOUR** questions in this Section. Answer any **THREE**.

1. (a) Clarify the concept of 'utility' in Economics. State the assumptions of the cardinal approach to utility analysis. Is there any limitations with these assumptions? If yes, identify. (10)
  
- (b) Explain the law of diminishing marginal utility with numerical as well as graphical presentations and draw the demand curve based on this law. (13 1/3)
  
2. (a) Given the demand function of a commodity X
 
$$Q_{dx} = 1080 - 19P_x + 0.01 M + 3.2P_y - 5.5 P_z$$
 Where, price of X,  $P_x = \text{tk. } 22$ , price of Y,  $P_y = \text{tk. } 45$ , price of Z,  $P_z = \text{tk. } 19$  and income,  $M = \text{tk. } 40000$ . Find the cross-price elasticities and income elasticity of X. What are the implications of the results you have obtained? (10)
  
- (b) Define price elasticity and cross-price elasticity of demand. How would you derive the formulae for measuring these two types of elasticity of demand? Describe the factors that govern the price elasticity of demand in general. (13 1/3)
  
3. (a) Clarify the concept of marginal rate of substitution (MRS) with graphical representations. Describe the relationship between MRS and marginal utility with the numerical examples. (10)
  
- (b) Define indifference curve and budget line. Illustrate the optimal consumption point under ordinal approach to utility analysis. (13 1/3)
  
4. Write short notes on any **THREE** of the following: (23 1/3)
  - (a) 'Change in demand' and 'change in quantity demanded'
  - (b) Basic economics problems
  - (c) 'Substitution effect' and 'income effect' of a price change
  - (d) Determinants of supply in general.

**HUM 113/WRE**

**SECTION – B**

There are **FOUR** questions in this Section. Answer any **THREE**.

5. (a) What is meant by the concept of market in Economics? Describe the various classifications of market. (5)
- (b) Explain the short run equilibrium of a firm under monopoly market. (6 1/3)
- (c) What is meant by the shut-down point of production? Graphically explain the shut-down point of production of a firm under perfect competition. (5)
- (d) Given the following total revenue (TR) and total cost (TC) functions for a firm (7)
- $$TR = 4000Q - 33Q^2$$
- $$TC = 2Q^3 - 3Q^2 + 400Q + 5000$$
- Where Q is quantity of output.
- (i) Set up the profit function.
- (ii) Find out the quantity which makes the profit maximum.
- (iii) Calculate the maximum profit and verify that it is maximized.
6. (a) Write down the statement of application of Euler's theorem in the theory of distribution of production. How can you show the exhaustion of factor income according to Euler's theorem? (10)
- (b) Discuss the various internal economies of scale of production. (6 1/3)
- (c) Define optimization. How can optimization be achieved? Why is optimization necessary with reference to the production of a firm? (7)
7. (a) Explain the concepts of gross national product (GNP), gross domestic product (GDP) and net national product (NNP). (5)
- (b) Briefly discuss the various methods of measuring national income of country like Bangladesh. (6 1/3)
- (c) Discuss any two difficulties in the measurement of national income in a developing country like Bangladesh. (5)

**HUM 113/WRE**

**Contd ... Q. No. 7**

(d) Calculate the national income from the following information: (7)

GNP = Tk. 1,20,000 crore

Depreciation = Tk. 9,000 crore

Indirect tax = Tk. 12,500 crore

Subsidy is 20% of indirect tax

8. (a) Discuss how J. M. Keynes has proved that savings and investment are equal. (7)

(b) Explain the concept of inflation. Briefly discuss the causes of inflation. (7 1/3)

(c) Briefly discuss the various policies for controlling inflation with reference to the context of Bangladesh. (10)

-----

The figures in the margin indicate full marks.

Symbols have their usual meaning.

USE SEPARATE SCRIPTS FOR EACH SECTION

**SECTION – A**

There are **FOUR** questions in this Section. Answer any **THREE**.

1. (a) Express  $A = \begin{bmatrix} 1 & 0 & -2 \\ 0 & 5 & 3 \\ 0 & 0 & -1 \end{bmatrix}$  as the product of elementary matrices. (12)

(b) Define inverse of a matrix. Prove that inverse of a matrix is unique. (10)

(c) Find the rank of the matrix  $A = \begin{bmatrix} 2 & 3 & -1 & -1 \\ 1 & -1 & -2 & -4 \\ 3 & 1 & 3 & -2 \\ 6 & 3 & 0 & -7 \end{bmatrix}$  by reducing it to echelon form. (13)

2. (a) If  $A = \begin{bmatrix} 2 & 4 & 6 \\ 4 & 9 & 12 \\ 0 & 10 & 1 \end{bmatrix}$ , find two non-singular matrices  $P$  and  $Q$  such that  $PAQ = I$ . Hence find  $A^{-1}$ . (20)

(b) For which values of  $k$ , the following system have (i) a unique solution, (ii) infinitely

$$\begin{aligned} x + 2y - 3z &= 4 \\ \text{many solutions, (iii) no solutions: } 3x - y + 5z &= 2 \\ 4x + y + (k^2 - 14)z &= k + 2 \end{aligned} \quad (15)$$

3. (a) Find the nullity of the matrix  $A = \begin{pmatrix} -1 & 2 & 0 & 4 & 5 & -3 \\ 3 & -7 & 2 & 0 & 1 & 4 \\ 2 & -5 & 2 & 4 & 6 & 1 \\ 4 & -9 & 2 & -4 & -4 & 7 \end{pmatrix}$  (15)

(b) State and verify Cayley-Hamilton theorem for the matrix  $A = \begin{bmatrix} 1 & -1 & 1 \\ 1 & 2 & 1 \\ 1 & 0 & 3 \end{bmatrix}$ . Hence find

$A^6$ . (20)

### MATH 133 /WRE

4. (a) Define quadratic form and explain its matrix representation. For the real symmetric matrix  $A$ , find a non-singular matrix  $P$  such that  $P^T A P$  is diagonal and also find its signature

where  $A = \begin{bmatrix} 1 & -3 & 2 \\ -3 & 7 & -5 \\ 2 & -5 & 8 \end{bmatrix}$  (18)

- (b) Find the eigenvalues, eigenvectors and eigenspaces of the matrix  $A = \begin{bmatrix} 4 & 0 & 0 \\ 3 & 3 & 0 \\ 2 & 3 & 1 \end{bmatrix}$ . Is the matrix  $A$  diagonalizable? (17)

#### SECTION - B

There are **FOUR** questions in this Section. Answer any **THREE**.

5. (a) A line makes angles  $\alpha, \beta, \gamma, \delta$  with the four diagonals of a cube. Find the value of  $\cos^2 \alpha + \cos^2 \beta + \cos^2 \gamma + \cos^2 \delta$ . (18)

- (b) Find the angle between the lines whose direction cosines are connected by the equation  $l + m + n = 0$  and  $2mn + 3nl - 5lm = 0$  (17)

6. (a) A variable plane is at a constant distance  $p$  from the origin and meets the axes in  $A, B$  and  $C$ . Through  $A, B, C$  planes are drawn parallel to the co-ordinate planes. Show that the locus of their point of intersection is  $x^{-2} + y^{-2} + z^{-2} = p^{-2}$ . (18)

- (b) Prove that the equation  $2x^2 - 6y^2 - 12z^2 + 18yz + 2zx + xy = 0$  represents a pair of planes and find the angle between them. (17)

7. (a) Show that the lines  $\frac{x}{1} = \frac{y-2}{2} = \frac{z+3}{3}$  and  $\frac{x-2}{2} = \frac{y-6}{3} = \frac{z-3}{4}$  are coplanar. Find their common point of intersection and the equation of the plane in which they lie. (18)

- (b) Find the length and equations of the line of shortest distance between the lines (17)

$$\frac{x-1}{2} = \frac{y-2}{3} = \frac{z-3}{4} \text{ and } \frac{x-2}{3} = \frac{y-4}{4} = \frac{z-5}{5}$$

8. (a) Find the equation of a sphere for which the circle  $x^2 + y^2 + z^2 + 7y - 2z + 2 = 0$ ,  $2x + 3y + 4z = 8$  is a great circle. (18)

- (b) Find the equation to the two planes which contain the lines given by  $7x + 10y - 30 = 0$ ,  $5y - 2z = 0$  and touch the conicoid  $7x^2 + 5y^2 + 3z^2 = 60$  (17)

-----

L-1/T-2 B. Sc. Engineering Examinations 2016-2017

Sub : **EEE 165** (Basic Electrical Technology)

Full Marks : 210

Time : 3 Hours

The figures in the margin indicate full marks.

Symbols have their usual meanings unless stated otherwise.

Assume any data if necessary.

USE SEPARATE SCRIPTS FOR EACH SECTION

**SECTION – A**

There are **FOUR** questions in this section. Answer any **THREE**.

1. (a) At a frequency  $\omega$ , the circuits in Fig. for Q. No. 1(a) have the same impedance between the terminal a, b. Show that (12)

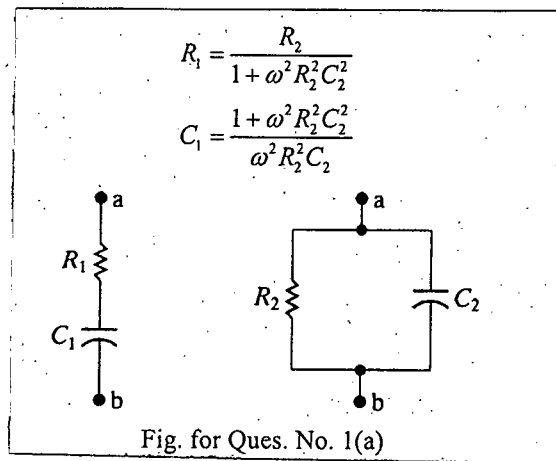

- (b) Find  $v_0(t)$  in the circuit of Fig. for Q. No. 1(b). (23)

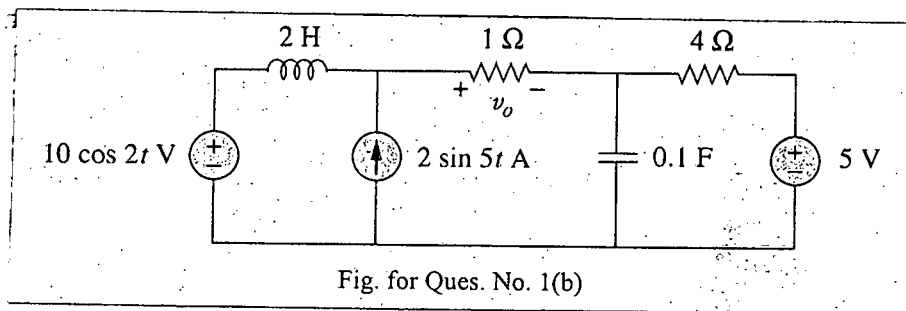

2. (a) Find the rms value of the periodic voltage shown in Fig. for Q. No. 2(a). When the voltage is applied to a resistor, the resistor dissipates 62.5 W of average power. What is the value of the resistor? (14)

**EEE 165/WRE**

**Contd ... Q. No. 2(a)**

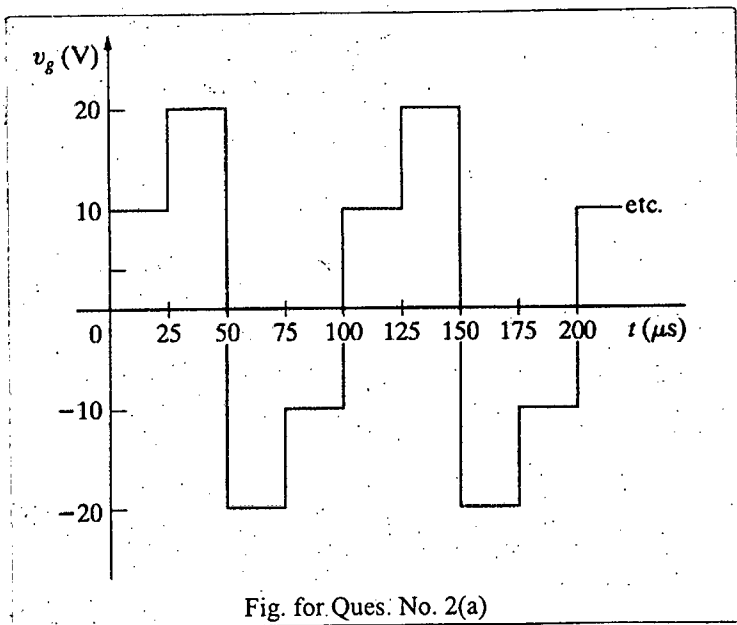

(b) What is the reading of the wattmeter in the network of Fig. for Q. No. 2(b)? (14)

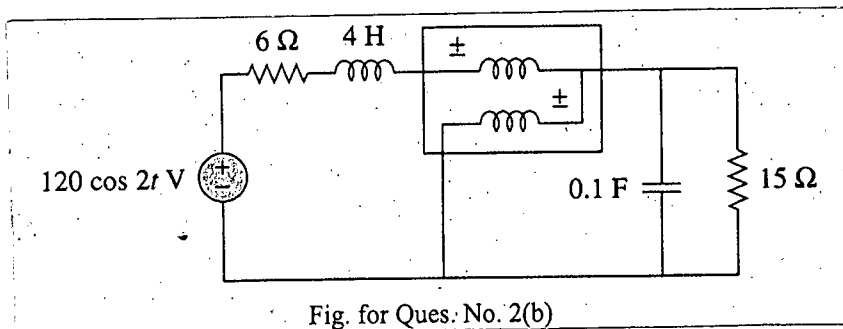

(c) Find the value of parallel capacitance needed to correct a load of 140 kVAR at 0.85 lagging pf to unity pf. Assume that the load is supplied by a 110-V (rms), 60-Hz line. (7)

3. (a) Show that for maximum average power transfer, the load impedance  $Z_L$  must be equal to the complex conjugate of the Thevenin impedance  $Z_{Th}$ . (15)

(b) A balanced wye-connected load is connected to a generator by a balanced transmission line with an impedance of  $0.5 + j2 \Omega$  per phase. If the load is rated at 450 kW, 0.708 power factor lagging, 440 V line voltage, find (20)

- (i) the load impedance per phase (ii) the line current
- (iii) the power loss in the line (iv) the line voltage at the generator.



**EEE 165/WRE**

4. (a) Define voltage regulation and efficiency of a transformer. With the help of phasor diagrams, explain how power factor of the load affects the voltage regulation. List and briefly describe the types of losses that occur in a transformer. (17)

(b) Data from short-circuit and open-circuit tests of a 60 Hz, 20 kVA, 20,000-480 V transformer are: (18)

$V_{OC} = 480 \text{ V}$	$V_{SC} = 1130 \text{ V}$
$I_{OC} = 1.60 \text{ A}$	$I_{SC} = 1.00 \text{ A}$
$P_{OC} = 3.5 \text{ W}$	$P_{SC} = 260 \text{ W}$

The transformer is operating at rated voltage, rated kVA and 0.8 power-factor leading in the step-up mode. Determine (i) efficiency; (ii) voltage regulation; (iii) voltage applied to the primary.

**SECTION - B**

There are **FOUR** questions in this section. Answer any **THREE**.

5. (a) Using nodal analysis find the power developed by the 20 V source in the circuit shown in Fig. for Q. No. 5(a). (25)

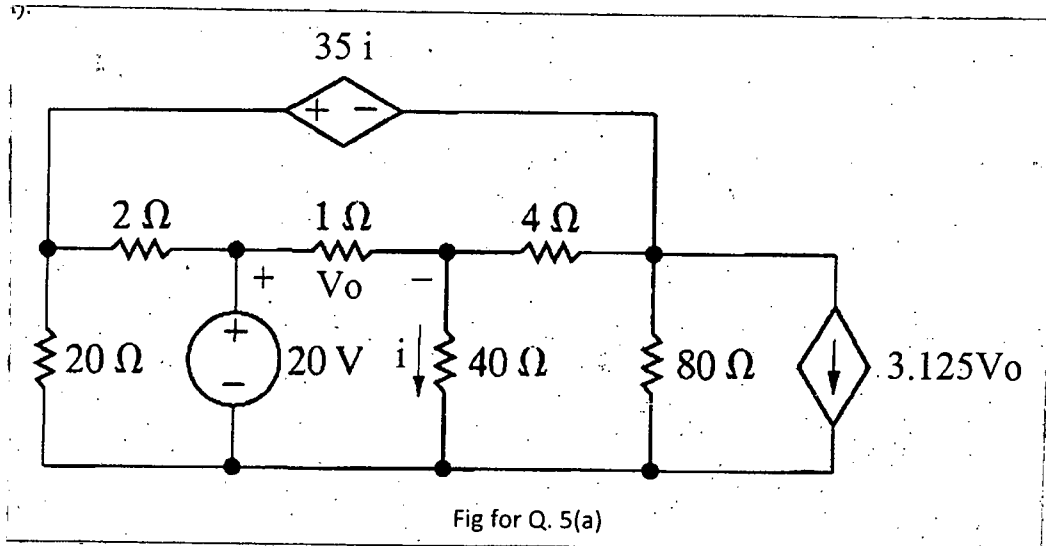

(b) For the circuit shown in Fig. for Q. 5(b), output voltage  $v_o$  is either 26 V or 24 V. The value of  $v_o$  depends on whether the switch is closed or open. Determine  $R_2$  and  $R_3$ . (10)

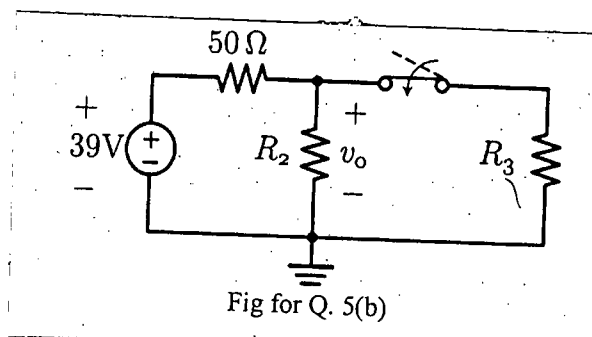

**EEE 165/WRE**

6. (a) Consider the circuit shown in Fig. for Q. No. 6(a).  $i$  (Current through the  $6\text{ k}\Omega$  resistor) was calculated to be  $3.5\text{ mA}$  before the  $5\text{ mA}$  current source was attached to the terminals  $a, b$ .

(25)

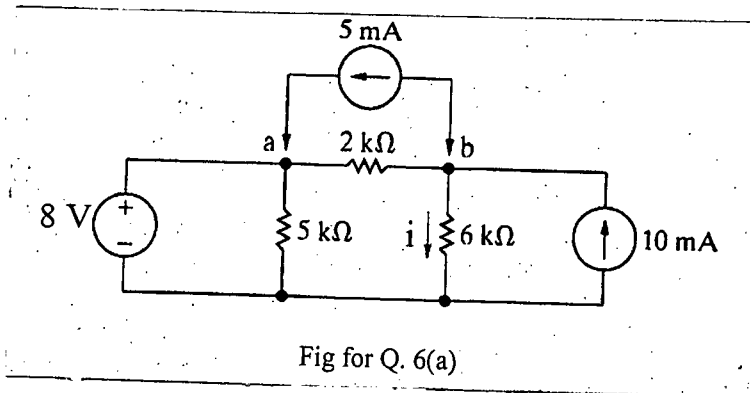

- (i) Using superposition theorem, find the value of  $i$  after the  $5\text{ mA}$  current source is attached.
- (ii) Using mesh analysis, verify your solution obtained in (i) when all three sources are acting simultaneously.

- (b) Find  $i_0$  in the circuit in Fig. for Q. 6(b) using source transformation.

(10)

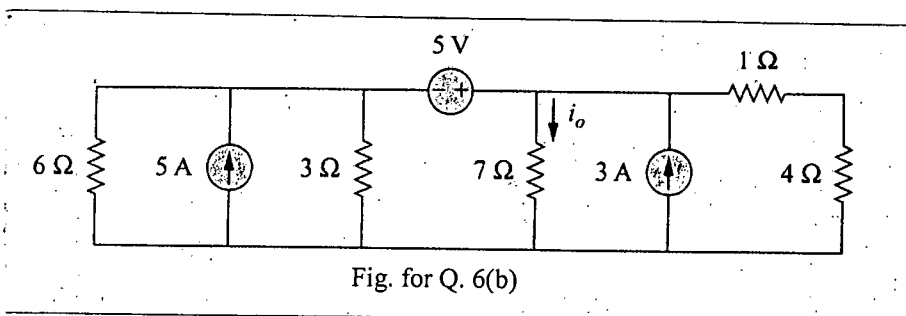

7. (a) Consider the circuit shown in Fig. for Q. 7(a). If  $\frac{V_{out}}{V_s} = 9$ , Find the value of  $A$ .

(15)

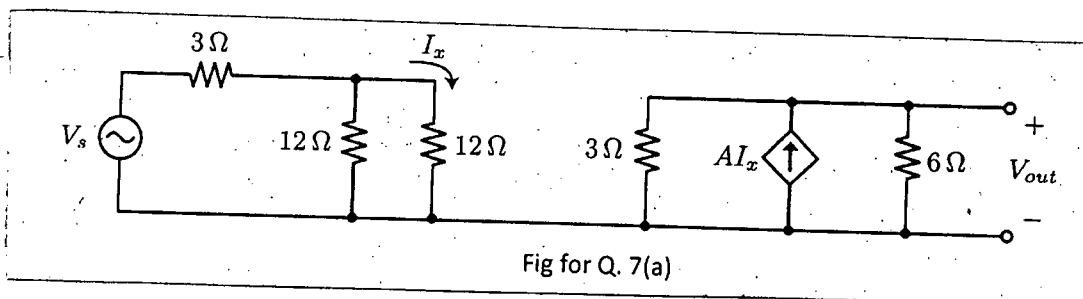

**EEE 165/WRE**

**Contd ... Q. No. 7**

(b) For the circuit shown in Fig. for Q. 7(b), find  $i$  using Thevenin's theorem.

(20)

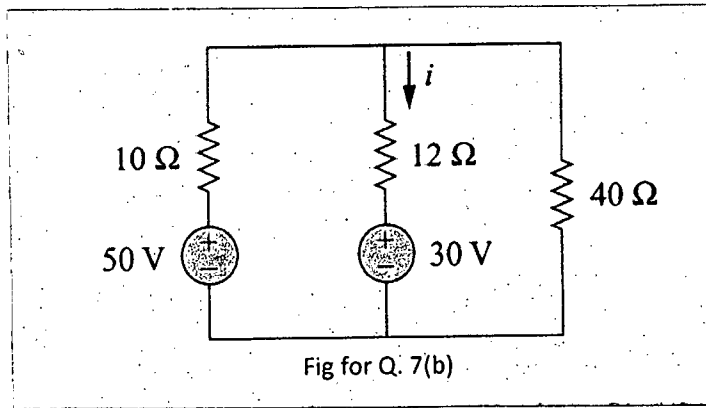

8: (a) Draw the per phase equivalent circuit and the power flow diagram of an induction motor. Derive the relationship between the converted power and airgap power in terms of the slip of an induction motor.

(25)

(b) For the circuit shown in Fig. for Q. No. 8(b), find  $R_{eq}$  and  $i_0$

(10)

