

The figures in the margin indicate full marks

Assume reasonable value of missing data, if any.

USE SEPARATE SCRIPTS FOR EACH SECTION

**SECTION – A**

There are **FOUR** questions in this section. Answer any **THREE**.

Use attached charts where necessary.

1. (a) A sample of clayey soil was tested for liquid limit in a cone penetrometer and the following results were obtained: (13 $\frac{2}{3}$ )

Cone penetration (mm)	16	18	22	25	30
Water content (%)	33	40	54	63	83

Determine the liquid limit of the soil and also check the results for single point method using the relevant data.

- (b) Define the following: (12)

(i) Shrinkage limit (ii) Thixotrophy (iii) Critical void ratio (iv) Undrained shear strength (v) Skempton's pore pressure coefficient B (vi) Coefficient of earth pressure at rest.

- (c) Draw neatly the Plasticity Chart according to Unified Soil Classification System (USCS) showing the classifications of different soil deposits. (10)

(d) A clay sample (liquid limit = 67%, plastic limit 35%, natural moisture content = 54%) was collected from a depth of 5 m below the ground level. Water table is at the ground level and saturated unit weight of the sample is 20 kN/m<sup>3</sup>. From a laboratory consolidation test the preconsolidation pressure of the sample was found to be 255 kN/m<sup>2</sup>. Estimate the undrained shear strength of the sample at that depth. In the normally consolidated state, assume volumes of  $K_o$ ,  $\phi'$  and  $A_f$  to be 0.5, 20° and 0.6, respectively. (11)

2. (a) Define structure of a soil. With neat sketches define various types of structure of coarse grained soil and clay soil. (11 $\frac{2}{3}$ )

- (b) Classify the following two inorganic soils according to USCS: (12)

Soil A: Percent finer No. 200 sieve (0.075 mm) = 93

Liquid limit = 58%

Plastic limit = 23%

Soil B: Percent finer No. 4 sieve (4.75 mm) = 92

Percent finer No. 10 sieve (2.0 mm) = 60

Percent finer No. 40 sieve (0.425 mm) = 30

Percent finer No. 200 sieve (0.075 mm) = 10

Liquid limit = 37%

Plastic limit = 26%

**CE 341**

**Contd... Q. No. 2(b)**

(c) Derive the following expression:

(13)

$$s_u = \frac{c' \cos \phi' + \sigma'_v \sin \phi' [k_0 + A_f (1 - k_0)]}{1 + (2A_f - 1) \sin \phi'}$$

Where the symbols bear their usual meanings.

(d) A smooth vertical wall of height 8 m retains a soft clay backfill of unit weight 17 kN/m<sup>3</sup>. For undrained condition ( $\phi = 0$ ) of the backfill, determine the following:

(10)

- (i) Depth of tension crack
- (ii) Active earth force before tension crack occurs.
- (iii) Active earth force after tension crack occurs.

Given, undrained shear strength of backfill = 30 kN/m<sup>2</sup>.

3. (a) For a soil, the following results were obtained from grain size distribution and Atterberg limit tests:

(7)

- % finer No. 200 sieve (0.075 mm) = 90
- Liquid limit = 52
- Plastic limit = 25

Classify the soil based on ASSHTO Classification System.

(b) The following results were obtained at failure in consolidated undrained (CU) triaxial compression tests conducted on two specimens of a saturated overconsolidated clay sample:

(14)

Specimen No.	Cell pressure (kN/m <sup>2</sup> )	Deviator stress (kN/m <sup>2</sup> )	Pore pressure (kN/m <sup>2</sup> )
1	100	410	-65
2	200	520	-10

Draw Mohr circles in a plain graph paper in terms of effective stresses and hence estimate the values of effective shear strength parameters ( $c'$  and  $\phi'$ ). Also write down the Mohr-Coulomb failure equation for the effective stress failure envelope.

(c) Draw the following qualitative curves:

(11 2/3)

- (i) Pore pressure versus axial strain for saturated samples of normally consolidated and overconsolidated clays in CU triaxial compression tests.
- (ii) Volumetric strain versus axial strain for saturated samples of normally consolidated and overconsolidated clays in consolidated drained (CD) triaxial compression tests.
- (iii) Variation of pore pressure parameter B with degree of saturation.
- (iv) Variation of pore pressure parameter A at failure ( $A_f$ ) with overconsolidation ratio (OCR).

**CE 341**

**Contd... Q. No. 3**

(d) For the retaining wall shown in Fig. 1, determine the force per unit length of the wall for Rankine's passive state. Also find the location of the total passive force. If the backfill supports a uniformly distributed load of 20 kN/m<sup>2</sup>, what will be the value of total passive force per unit length of the wall?

(14)

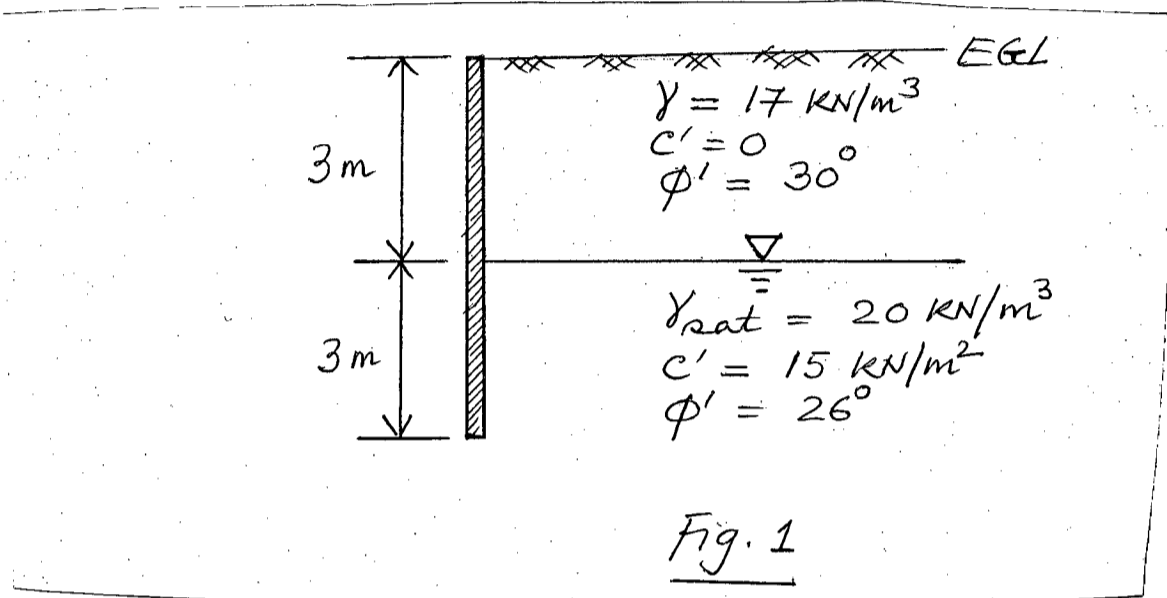

4. (a) What are the advantages of triaxial test? Describe briefly the behaviour of saturated clay samples in unconsolidated undrained (UU) triaxial compression test. Also show with neat sketches two examples of UU analysis in clays.

(12)

(b) Two identical specimens of a saturated normally consolidated clay sample were fully consolidated in the triaxial cell under a cell pressure of 150 kN/m<sup>2</sup>. Pore pressure within each specimen at the end of consolidation was zero. One specimen was then sheared under undrained condition and the other under drained condition until failure took place. The values of deviator stress at failure in the undrained and drained tests were found to be 225 kN/m<sup>2</sup> and 325 kN/m<sup>2</sup>, respectively. Calculate the values of  $\phi'$  and  $\phi_u$ . Also calculate the value of pore pressure parameter A at failure ( $A_f$ ).

(10)

(c) The following results were obtained in a consolidated drained direct shear test conducted on a clay sample.

(15)

Specimen No.	Normal Force (N)	Peak Shear Force (N)	Residual Shear Force (N)
1	150	158	44
2	350	257	102
3	550	363	144.5

Diameter and height of each specimen were 50 mm and 25 mm, respectively. Determine the effective peak friction angle ( $\phi'_p$ ) and effective residual friction angle ( $\phi'_r$ ). Also comment on the stress history of the sample.

(d) State the assumptions used in Rankine's theory of earth pressure. Deduce an expression for active earth pressure due to a C- $\phi$  backfill.

(9 2/3)

**CE 341**

**SECTION – B**

There are **FOUR** questions in this section. Answer any **THREE**.

5. (a) The data from a standard Proctor and Modified Proctor compaction test on a soil ( $G_s = 2.64$ ) are given as: (21 <sup>2</sup>/<sub>3</sub>)

<b>Standard Proctor</b>						
Water Content (%)	9.3	11.8	14.3	17.6	20.8	23.0
Dry density ( $t/m^3$ )	1.691	1.715	1.755	1.747	1.685	1.619

<b>Modified Proctor</b>					
Water Content (%)	9.3	12.8	15.5	18.7	21.1
Dry density ( $t/m^3$ )	1.873	1.910	1.803	1.699	1.641

- (i) Plot the compaction curves along with zero air void line and find the optimum water content and the maximum dry density for each test.
- (ii) Compaction tests carried out at three locations in the field and the results are as follows:

Test No.	Volume of Soils ( $cm^3$ )	Mass of the wet soil (gm)	Mass of dry soil (gm)
1	946	1822	1703
2	980	2083	1882
3	957	1960	1675

Compute the dry density, bulk density and water content for each test and plot the points in the above graph along with the compaction curves.

- (iii) The compaction specification requires that the in situ dry density be greater than or equal to 95% of the maximum dry density from modified Proctor compaction test and for the water content to be within 2% (plus or minus) of the modified Proctor optimum water content. Determine which of the three tests meet the specifications and also give reasons why the specifications were not met for the tests that failed.
- (b) A sample of sand above water table was found out to have a moisture content of 15% and a unit weight of  $18.84 \text{ kN/m}^3$ . Laboratory test on a dry sample indicated values  $e_{\min} = 0.50$  and  $e_{\max} = 0.85$  for the densest and loosest states respectively. Compute the degree of saturation and the relative density. Assume  $G_s = 2.65$ . What will be the saturated density of sand in the field? (15)

- (c) There are two ways of specifying compaction of earthworks — Explain. (10)

**CE 341**

6. (a) A rigid foundation block, circular in plan, 6.0 m diameter rests on a sand bed of 5.5 m thick. Below the sand, there is a 1.6 m of clay layer overlaying impervious rock. Ground water table is 1.5 m below the ground surface. The densities of sand above the and below the water table are 19.2 and 20.8 kN/m<sup>3</sup> respectively. The saturated density of clay is given as 19.9 kN/m<sup>3</sup>. Draw the schematic diagram of the problem. A consolidation test performed on an undisturbed sample of the clay 20 mm thick and drained at the top and bottom gave the following results: (26<sup>2</sup>/<sub>3</sub>)

Pressure (kN/m <sup>2</sup> )	50	100	200	300	400
Void Ratio	0.73	0.68	0.625	0.58	0.54

If the foundation block is subjected to a uniform pressure of 270 kN/m<sup>2</sup>,

- (i) Estimate the settlement of the foundation assuming the load spread is 1 horizontal to 2 vertical.
  - (ii) If the consolidation test sample reached 90% consolidation in two hours, how long it will take the foundation to reach 90% of its final settlement?
  - (iii) Calculate the magnitude of foundation settlement after 4.5 years.
- (b) Write down the step by step procedure for constructing field **e vs. log (p)** curve for OC clays. (10)
- (c) Write short notes on (i) coefficient of volume compressibility, and (ii) secondary consolidation. (10)

7. (a) Seepage takes place beneath the concrete dam with vertical cut off (2 m length) is shown in Fig. 2. The permeability of the fine, silty sand beneath the dam is  $3.6 \times 10^{-4}$  cm/sec. Find the following: (26<sup>2</sup>/<sub>3</sub>)

- (i) The seepage loss in m<sup>3</sup>/day per meter run;
  - (ii) The safety factor with respect to piping/heaving, assuming the void ratio is 0.8 and the specific gravity of soil grains is 2.66; and
  - (iii) Uplift pressure diagram at the bottom of the dam.
- (b) Describe the mechanism of piping. How the factor of safety against piping can be increased for a hydraulic structure? (10)
- (c) Why a filter is used on the downstream side an earth dam/embankment? How would you design a filter? What is graded filter? (10)

**CE 341**

8. (a) Two clay samples A and B of thickness 3 cm and 4 cm have final voids ratios of 0.65 and 0.71, respectively, under a pressure of  $225 \text{ kN/m}^2$ . If the final void ratios of the same two soil samples are reduced to 0.48 and 0.59 respectively when the pressure is increased to  $450 \text{ kN/m}^2$ . **(15)**

Find the ratio of the coefficient of permeability of the two specimens. Given that the time required by the specimen A to reach 50% degree of consolidation is one third of that required by the specimen B for reaching 50% degree of consolidation.

- (b) A point load of 50,000 kN is applied at the ground surface. Calculate vertical stress 7.5 m away horizontally and 15 m below the ground level. Also calculate the maximum vertical stress below the ground surface at a point 7.5 m laterally from the point of application of the load 50,000 kN. **(16)**

- (c) Calculate the magnitude of vertical pressure at A which is 21 feet below the ground level due to an embankment loading as shown in Fig. 3. **(15 $\frac{2}{3}$ )**

-----

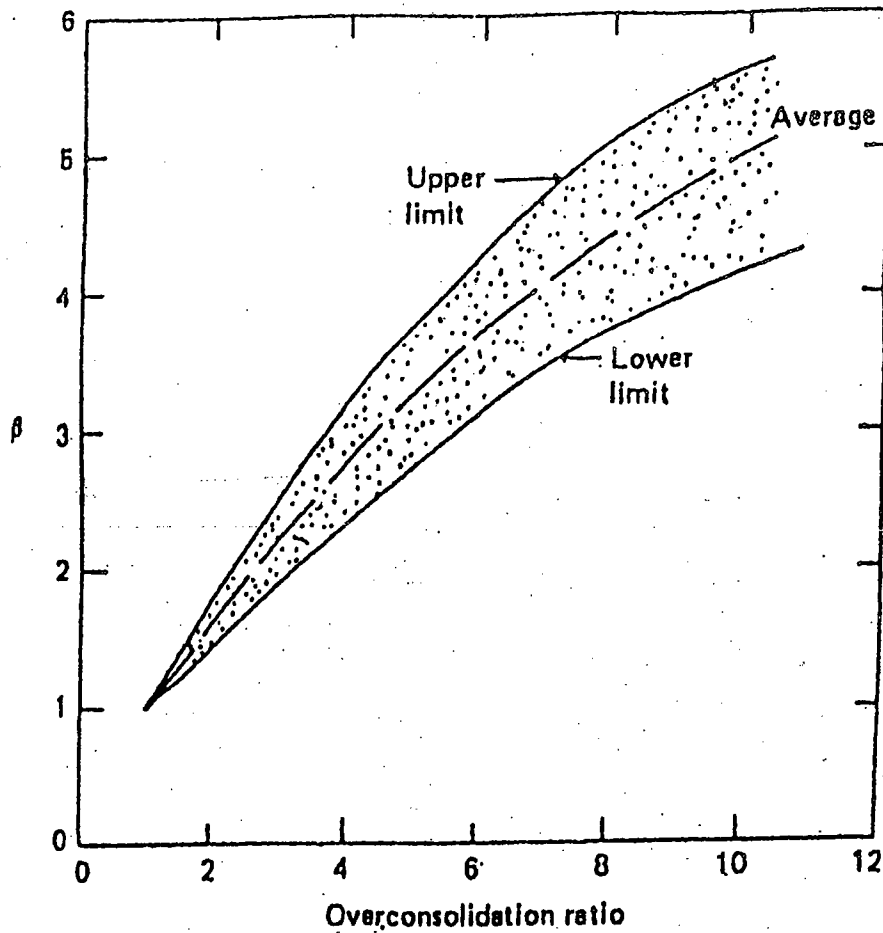

Chart 1 Plot of  $\beta$  versus overconsolidation ratio

General Classification	Granular Material (35% or less passing No. 200 sieve)						Silt Clay Materials (More than 35% passing No. 200 Sieve)				
	A-1		A-3	A-2			A-4	A-5	A-6	A-7	
Group Classification	A-1-a	A-1-b		A-2-4	A-2-5	A-2-6	A-2-7			A-7-5	A-7-6
<b>Sieve Analysis; Percent Passing</b>											
No. 10	50 max	--	--	--	--	--	--	--	--	--	--
No. 40	30 max	50 max	51 min	--	--	--	--	--	--	--	--
No. 200	15 max	25 max	10 max	35 max	35 max	35 max	35 max	36 min	36 min	36 min	36 min
<b>Characteristics of fraction passing No. 40</b>											
Liquid Limit	--	--	40 max	41 min	40 max	41 min	40 max	41 min	40 max	41 min	41 min*
Plasticity Index	5 max		N.P.	10 max	10 max	11 min	11 min	10 max	10 max	11 min	11 min*
<b>Usual types of significant constituent materials</b>	Stone Fragments; gravel and sand		Fine sand	Silty or clayey gravel and sand			Silty soils		Clayey soils		
<b>General Rating as Subgrade</b>	Excellent to good						Fair to poor				

- Plasticity index of A-7-5 subgroup is equal to or less than L.L. minus 30.
- Plasticity index of A-7-6 subgroup is greater than L.L. minus 30.

Chart 2 AASHTO soil classification system (after Atkins, 1997)

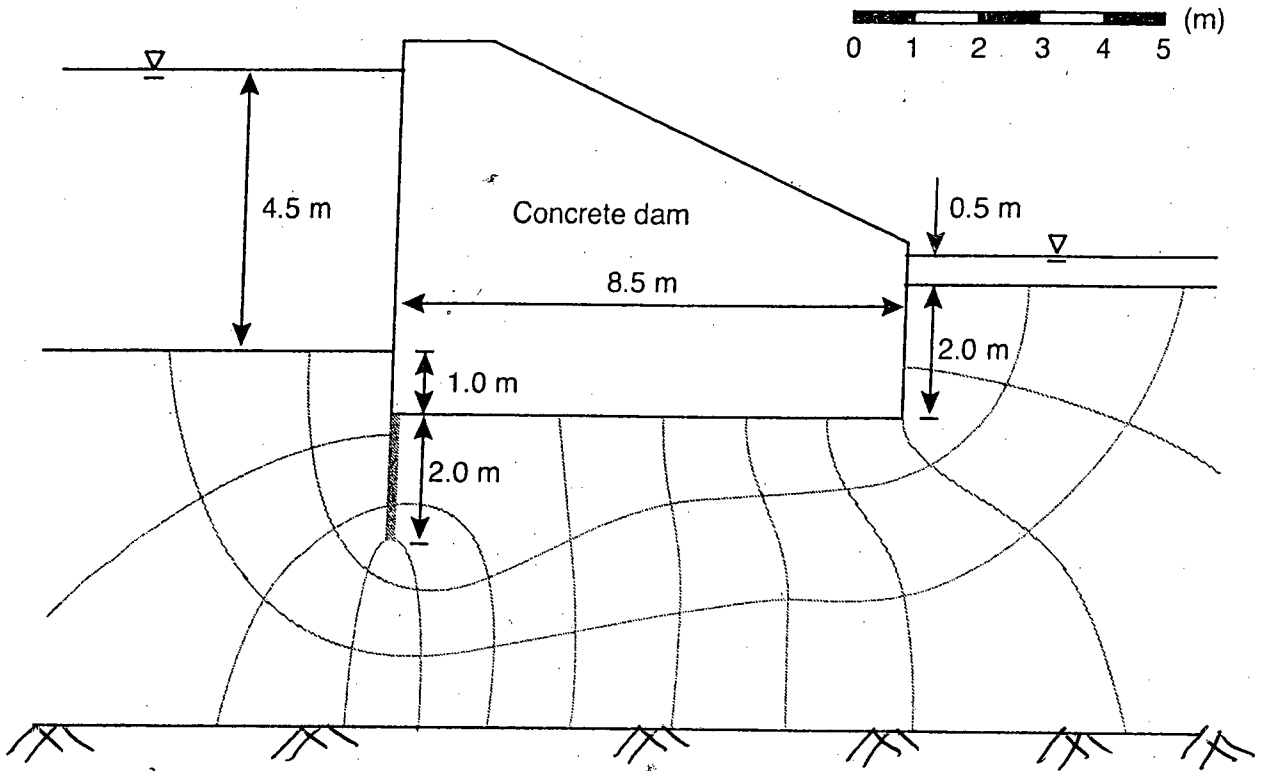

Fig. 2

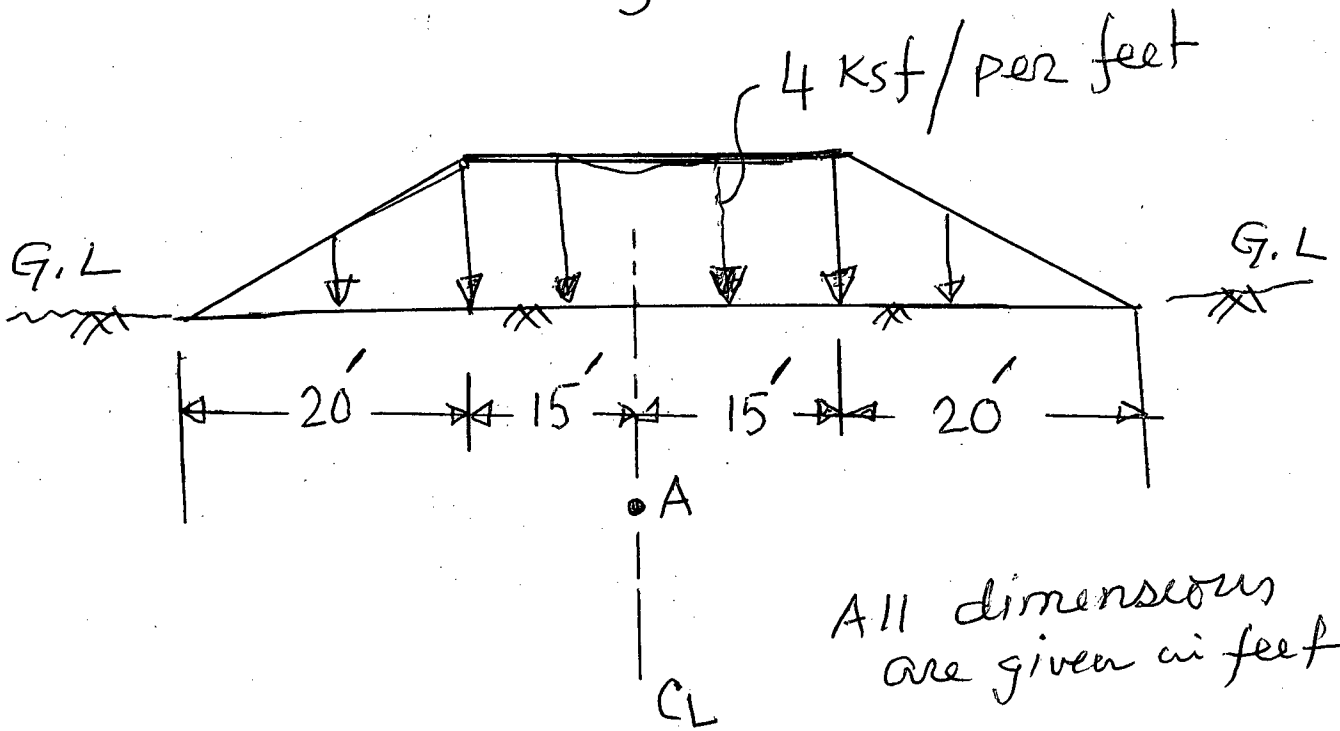

Fig. 3



**SECTION – A**

There are **FOUR** questions in this section. Answer any **THREE**.

1. (a) ) What are the general impacts of climate change in Bangladesh? Briefly explain the causes of climate change. How could you minimize the transmission of diseases from faeces? (18)  
 (b) What are the different factors affecting 'per capita demand of water'? (17)  
 The population of a city was 20 million in 1970, 26 million in 1980, 34 million in 1990, 48 million in 2000 and 70 million in 2010. Estimate the probable population in 2020 and 2030 by the least square parabola method.
2. (a) Why is the hydrologic cycle important? What are the major obstacles of groundwater supply in Bangladesh? Show the essential elements of a surface water based water supply system in a neat sketch. (18)  
 (b) A 150 mm diameter well in a water table aquifer is being pumped at a rate of 2,500 litre/min with a drawdown of 8.5 m. The static depth of water in the well is 45 m. During pumping, the depth of water in a similar well, not being pumped, situated at a distance of 6.5 m is 42 m. At what rate could water be pumped from the two wells if both the wells are pumped together with a drawdown in each well of 8 m? (17)
3. (a) What are the main objectives of water demand management? Show the typical locations of losses in water supply system. What are the different types of tubewell technologies used in Bangladesh? Draw a neat sketch of reverse rotary recirculation method of drilling wells. (20)  
 (b) A settling column analysis of a flocculation suspension is being performed. The initial suspended solids concentration is 300 mg/l and column depth is 3m. The resulting removal fractions with iso-removal lines are shown in Figure 1 (enclosed). What will be overall efficiency of suspended solids removal of a settling basin having 3m depth with a detention time of (i) 90 minutes and (ii) 180 minutes? (15)
4. (a) What are the typical differences between water quality of surface and ground water? Delineate the treatment process diagrams for surface and ground water highlighting the differences between the two processes. (15)  
 (b) What are the advantages of split treatment in softening? When is split treatment usually done? Determine the lime and soda ash dosages for split treatment softening of the following water: (20)

**CE 331**

Contd... Q. No. 4(b)

Constituent	mg/l
CO <sub>2</sub>	11
Ca <sup>2+</sup>	55
Mg <sup>2+</sup>	22
Na <sup>+</sup>	15
Cl <sup>-</sup>	70
SO <sub>4</sub> <sup>2-</sup>	21.2

Biocarbonate alkalinity = 140 mg/l as CaCO<sub>3</sub>.

The finished water criteria is a maximum hardness of 40 mg/l as CaCO<sub>3</sub> and the total hardness in the range of 80-120 mg/l as CaCO<sub>3</sub>.

**SECTION – B**

There are **FOUR** questions in this section. Answer any **THREE**.

5. (a) Explain the process of ion-exchange for demineralization (with diagram). How is the ion exchange media regenerated? **(10+2)**
- (b) What are the typical applications of reverse osmosis? What is the difference between reverse osmosis and electro dialysis? **(4+4)**
- (c) What are the different strategies of irons removal when sufficient alkalinity is not present? Describe the theory and process of Arsenic removal. **(8+7)**
6. (a) Write short notes on: **(5×4=20)**
- (i) Disinfection-by-products (DBPs)
  - (ii) Filter backwashing
  - (iii) Sweep floc coagulation
  - (iv) Two-film theory of gas transfer
- (b) Discuss briefly the factors affecting the corrosion of metallic pipes. How corrosion of metallic pipes can be controlled? **(15)**
7. (a) What is a water safety plan? Discuss briefly the steps of the water safety plan processes with flow diagram. **(20)**
- (b) For a tubewell based community water supply system in a rural area, possible contamination of well water due to leaching from pit latrine is considered to be a hazardous event. Determine the risk score and risk category for this hazardous event. **(15)**
8. (a) What are the characteristics of centrifugal pumps? State with necessary diagram. **(10)**
- (b) "A continuous water supply always better than intermittent water supply."(Justify the statement. **(12)**
- (c) Discuss 'dead end' layout of water supply network with merits and demerits. **(13)**
-

= 3 =

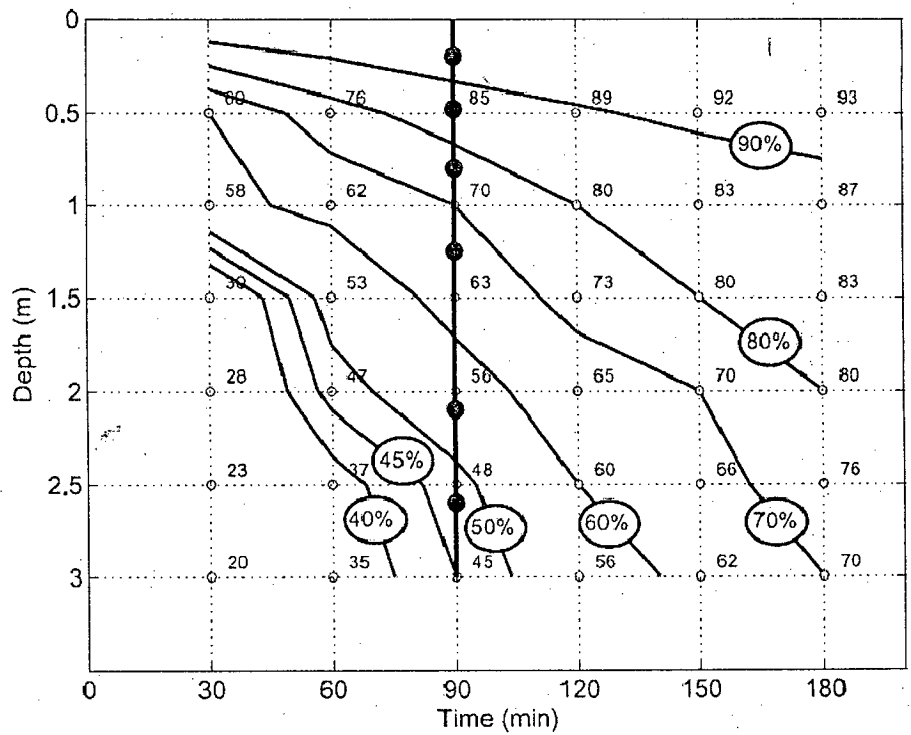

Figure-1

For Q#3(b)

The figures in the margin indicate full marks

Use USD Method of Design. Assume reasonable value for any missing data.

USE SEPARATE SCRIPTS FOR EACH SECTION

**SECTION – A**

There are **FOUR** questions in this section. Answer any **THREE**.

1. (a) What are the sources of uncertainties in analysis, design and construction of RC structure? Discuss how safety is ensured against these uncertainties in USD method. (7)
  - (b) Discuss the behavior of RC rectangular beam in flexure under increasing load by drawing neat sketches for strain and stress distribution of uncracked, cracked and ultimate conditions. (8)
  - (c) A singly reinforced RC beam section, as shown in Fig. 1, has a width of 12 in., effective depth of 22 in. and total depth of 25 in. The tension reinforcement consists of three No. 10 bars in one row, (20)
- Given:  $f'_c = 4$  ksi and  $f_y = 60$  ksi,  $f_s = 24$  ksi,  $f_r = 7.5 \sqrt{f'_c}$  psi,  $n = 8$ .
- Find stresses in concrete and steel caused by bending moments:
- (i)  $M = 50$  kip-ft.
  - (ii)  $M = 100$  kip-ft.
2. (a) What is the purpose of providing minimum amount of flexural steel in beam? Write ACI/BNBC code provisions for minimum reinforcement ratios. (5)
  - (b) Discuss how a minimum tensile strain ( $\epsilon_t = 0.004$ ) at failure is ensured by not exceeding maximum reinforcement ratio. Also discuss the variation of  $\phi$  with  $\epsilon_t$  as given in ACI/BNBC code. (10)
  - (c) A beam section is limited to width  $b = 12$  in. and total depth  $h = 25$  in. Calculate the required reinforcement if the beam has to resist a factored moment  $M_u = 500$  kip-ft. Assume two layer tensile reinforcement with  $d = 21$  in. and  $d_t = 22.5$  in. Also, assume  $d' = 2.5$  in. if compression steel is required. (20)
- Given:  $f'_c = 4$  ksi,  $f_y = 60$  ksi.
3. (a) A floor system consists of a 3 in. concrete slab supported by continuous T beams with a 24 ft span, 48 in. on centres is shown in Fig. 2. Web dimensions are  $b_w = 12$  in. and  $d = 20$  in. Find the nominal and design positive moment capacity of the section if tensile steel area is: (20)
- (i)  $A_s = 6$  in<sup>2</sup>
  - (ii)  $A_s = 9$  in<sup>2</sup>
- Given:  $f'_c = 4$  ksi,  $f_y = 60$  ksi.

**CE 315**

**Contd... Q. No. 3**

(b) A rectangular beam carries a service live load (unfactored) of 2.5 kip/ft and an unfactored superimposed dead load of 1.5 kip/ft (in addition to self-weight of beam) on a 20 ft simple span as shown in Fig. 3. The beam will have a cross-section of 12" × 24" for architectural reason. Design the beam for flexure using USD method.

(15)

Given:  $f'_c = 3.5$  ksi,  $f_y = 60$  ksi.

4. (a) A rectangular beam has width 14 in. and effective depth 25 in. as shown in Fig. 4. It is reinforced with eight No. 9 bars in two rows ( $d = 25"$ ,  $d_t = 26.5"$ ). What is the nominal flexural strength  $M_n$  and what is the maximum moment  $\phi M_n$  that can be utilized in the design?

(15)

Given:  $f'_c = 5.0$  ksi,  $f_y = 60$  ksi.

(b) A rectangular RC beam as shown in Fig. 5 measures 12 in. wide and has an effective depth of 27 in. Tension steel consists of six No. 10 bars in two layers ( $d = 27$  in.,  $d_t = 28.5$  in.) and compression steel consists of three No. 10 bars is located 2.5 in. from the compression face. What is the design moment capacity of the beam according to ACI/BNBC code? Check for yielding of compression steel and  $\epsilon_t$ .

(20)

Given:  $f'_c = 4.5$  ksi,  $f_y = 60$  ksi.

**SECTION - B**

There are **FOUR** questions in this section. Answer any **THREE**.

5. (a) A 14 ft clear span one-way slab with an overhanging cantilever span of 5 ft as shown in Fig. 6 is to be designed. The slab supports live load 100 psf in addition to its own weight. Design the slab for maximum positive and negative moments. The live load can occupy any portion or any position on the slab. Given: PW load = 50 psf; FF load = 30 psf;  $f'_c = 3000$  psi and  $f_y = 60,000$  psi.

(23)

(b) What are the minimum reinforcements and their maximum spacing for two-way and one-way slabs? Discuss why and how temperature and shrinkage reinforcement is provided in one-way slab.

(12)

6. (a) Design a singly reinforced beam shown in Fig. 7. The dead load does not include self-weight of the beam. Assume  $f'_c = 3.0$  ksi;  $f_y = 60$  ksi;  $b = 12"$  &  $\rho = 0.7 \rho_{max}$ .

(17)

(b) Design the stirrups for the beam in Q. 6(a) and make a neat sketch showing the stirrups.

(18)

**CE 315**

7. (a) Describe with neat sketches five reinforced concrete floor slabs commonly used in Bangladesh. (10)
- (b) Discuss in short about the special reinforcements provided at exterior corners of a two-way slab system. (10)
- (c) Why does ACI/BNBC code recommend increased development lengths for bars in a bundled group of reinforcements? Mention the recommended increased lengths for such bars. (8)
- (d) What are the minimum length of lap for column splices as per BNBC code? (7)
8. (a) A 4-span beam with a cantilever on one side is shown in Fig. 8. For a certain loading system the required flexural reinforcement areas calculated from corresponding design moments at different positions are given in Fig. 8. Make a detail drawing showing all the reinforcements. Columns are 24" × 24" and beam size is 12" × 24". Make sections also. (20)
- (b) Show with neat sketches cut off or bend points for bars in approximately equal spans with uniformly distributed loads. (8)
- (c) What are the BNBC/ACI code provisions for beam stirrups (hoops) for moderate seismic risk region e.g., Dhaka? (7)

-----

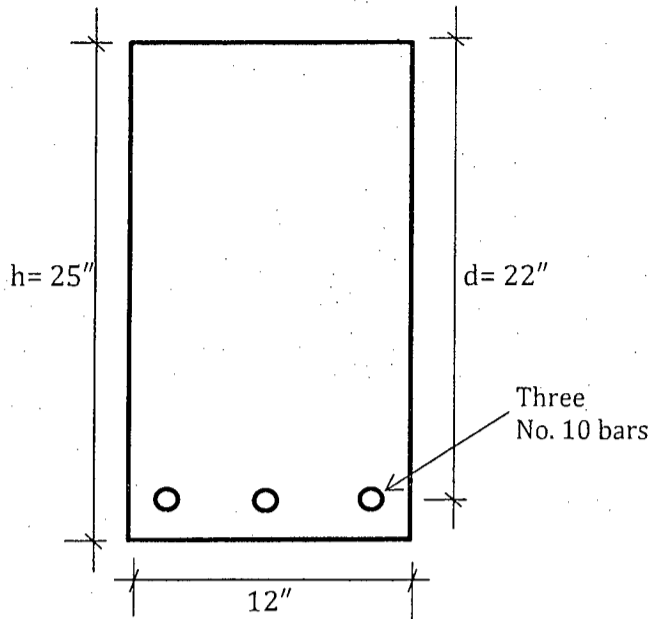

Given:

$f'_c = 4 \text{ ksi}$

$f_y = 60 \text{ ksi}$

$f_s = 24 \text{ ksi}$

$f_r = 7.5\sqrt{f'_c} \text{ psi}$

$n = 8$

Find stresses in concrete and steel caused by bending moments:

(i)  $M = 50 \text{ kip-ft.}$

(ii)  $M = 100 \text{ kip-ft.}$

Fig. 1

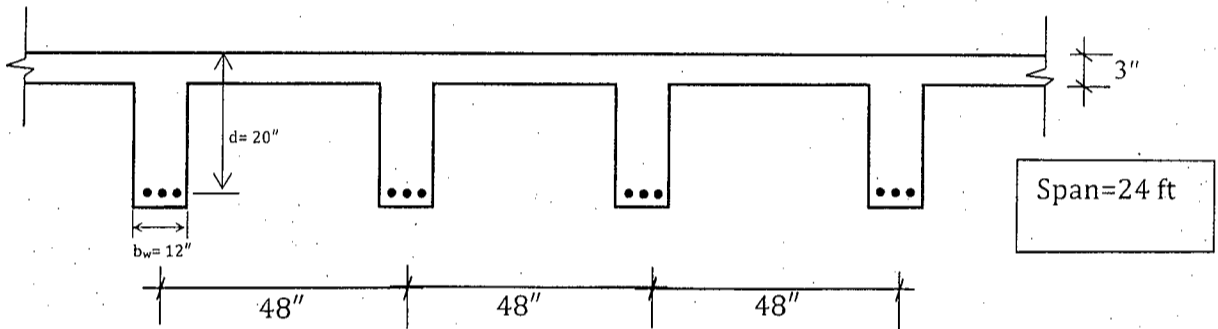

Given:

$f'_c = 4 \text{ ksi}$

$f_y = 60 \text{ ksi}$

Find the nominal and design positive moment capacity of the section if tensile steel area is:

(i)  $A_s = 6 \text{ in}^2$

(ii)  $A_s = 9 \text{ in}^2$

Fig. 2

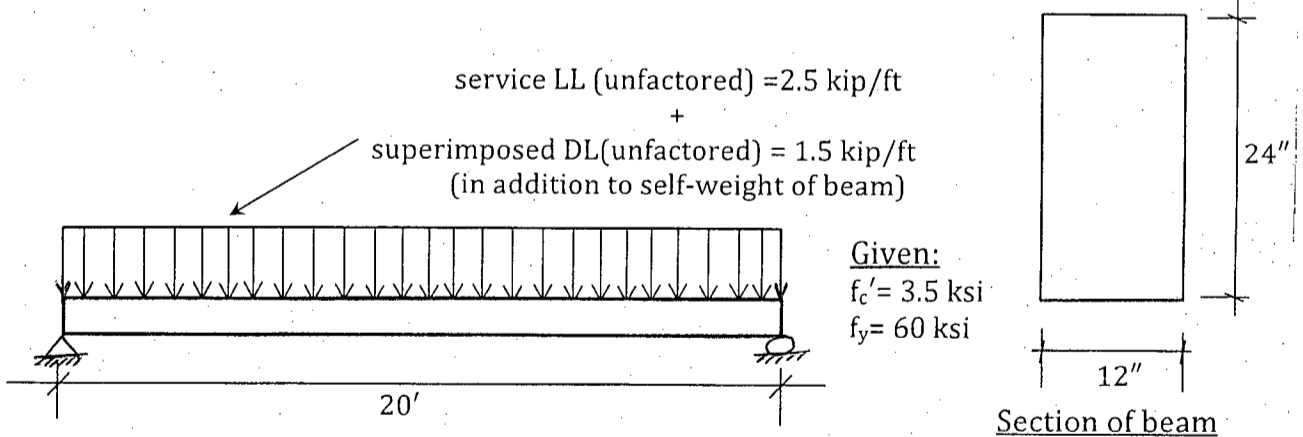

Given:

$f'_c = 3.5 \text{ ksi}$

$f_y = 60 \text{ ksi}$

Fig. 3

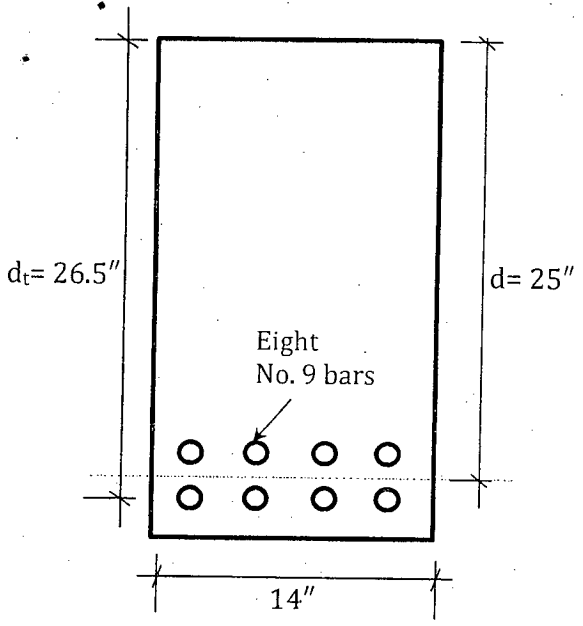

Given:  
 $f'_c = 5.0$  ksi  
 $f_y = 60$  ksi

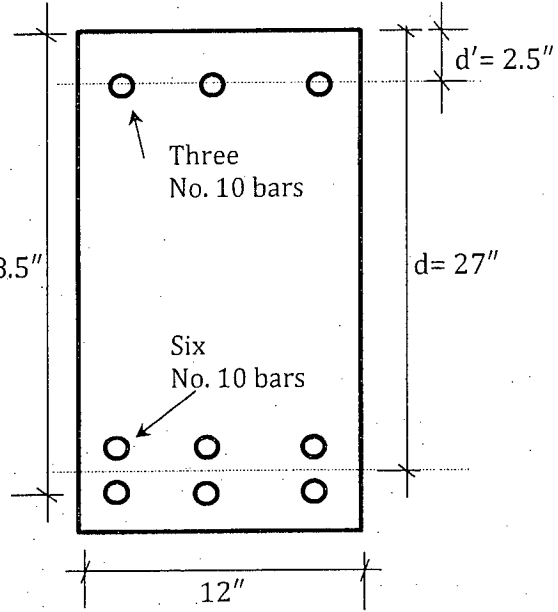

Given:  
 $f'_c = 4.5$  ksi  
 $f_y = 60$  ksi

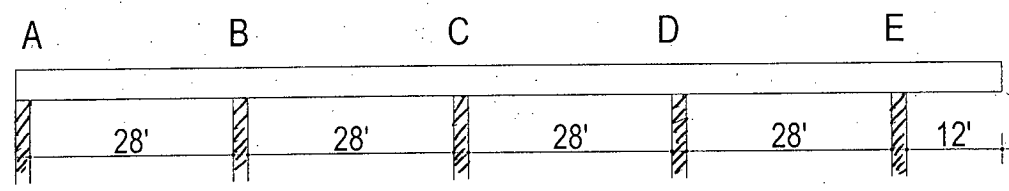
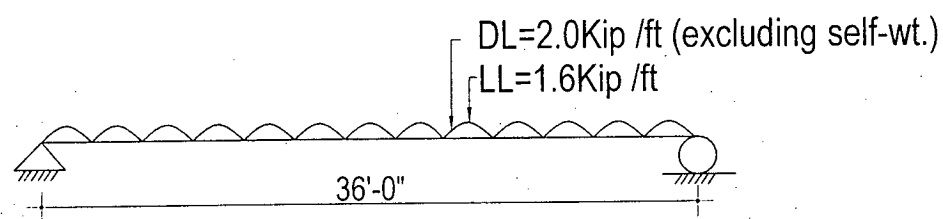
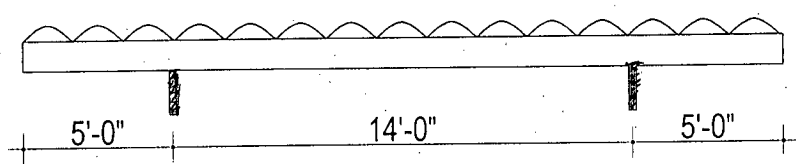

$+A_s(A-B) = 4.3 \text{ in}^2$	$+A_s(C-D) = 2.96 \text{ in}^2$
$-A_s(B) = 4.8 \text{ in}^2$	$-A_s(D) = 4.4 \text{ in}^2$
$+A_s(B-C) = 2.96 \text{ in}^2$	$+A_s(D-E) = 2.3 \text{ in}^2$
$-A_s(C) = 4.4 \text{ in}^2$	$-A_s(E) = 5.2 \text{ in}^2$



BANGLADESH UNIVERSITY OF ENGINEERING AND TECHNOLOGY, DHAKA

L-3/T-1 B. Sc. Engineering Examinations 2017-2018

Sub: **CE 301** (Professional Practice and Communication)

Full Marks: 210

Time: 3 Hours

The figures in the margin indicate full marks

USE SEPARATE SCRIPTS FOR EACH SECTION

---

**SECTION – A**There are **FOUR** questions in this section. Answer any **THREE**.

1. (a) Distinguish between Act and Regulation and in this connection explain the functionality of PPA-2006 and PPR 2008. (15)  
(b) Name the different types of tendering methods for procurement of works and goods. Explain the suitability of each method for any particular situation. (20)
2. (a) Describe the tender process using a flow-chart. Write the steps of tender evaluation. (25)  
(b) List, in order of priority, the documents that form the Contract. (10)
3. (a) Explain why specification is necessary. Describe the attributes of good specification. (15)  
(b) Write a specification for concrete (or brick) works in a high rise building showing requirements of material quality, transportation, workmanship, testing, measurement and payment. (20)
4. (a) In a standard format prepare a BoQ for brickwork in a multi-storied building. Consider 50 m<sup>3</sup> of work volume for brick work. (10)  
(b) For a construction contract, establish the relationship between GCC and PCC for the following: (25)
  - (i) Definitions of "The Employer", "Contractor", "The Engineer", and "Day";
  - (ii) Performance Security;
  - (iii) Variation;
  - (iv) Payment;
  - (v) Settlement of Disputes.

**CE 301**

**SECTION – B**

There are **FOUR** questions in this section. Answer any **THREE**.

5. (a) Define 'Civil Engineers' as per ASCE Body of knowledge. (5)  
(b) Briefly describe Ancient Structural System. (10)  
(c) Define Project. Briefly describe Scope-Schedule-Budget triangular relationship. (10)  
(d) Draw the flow of work in project development. (10)
6. (a) Why 'construction document' phase has higher emphasis during design phase? (7)  
(b) Briefly discuss quality control plan. (7)  
(c) Briefly describe the three main elements of verbal communication. What is defined as problem and barrier to communication? List the major problems. Briefly explain abstraction. (17)  
(d) What are the 'Common Client Concerns' during predesign? (4)
7. (a) Briefly discuss 6 types of contract systems in project delivery. (15)  
(b) Briefly discuss the most important aspects of inquiry by surety companies before issuing bonds. (10)  
(c) Write short notes on: (10)  
(i) General Liability Insurance  
(ii) Fiduciary Risk  
(iii) Project Characteristics.
8. (a) Define communication. Describe briefly the process of human communication. Explain why is communication important? (17)  
(b) What is project proposal? What do supplementary parts of a project proposal generally contain? Briefly describe chronology of procedures for solicited major proposals. (18)
-