

**SECTION – A**

There are **FOUR** questions in this Section. Answer any **THREE**.

1. (a) Determine the largest end forces  $P$  that the member can support if the allowable shear stress,  $\tau_{\text{Allow}} = 10$  ksi. The supports at A and B only exert vertical reactions on the beam. see Fig. 1. (20)
- (b) A box beam is to be constructed from four boards nailed together as shown in Fig. 2. If each nail can support a shear force of 30 lb, determine the maximum spacing 's' of nails at B and C so that the beam can support the vertical force of 80 lb as shown in Fig. 2. (15)
2. (a) The solid shaft is subjected to the distributed and concentrated torsional loading as shown in Fig. 3. Determine the required diameter 'd' of the shaft if allowable shear stress for the material is  $\tau_{\text{Allow}} = 175$  MPa. (17)
- (b) The shaft of radius  $c$  is subjected to a distributed torque  $t$ , measured as torque/length of the shaft as shown in Fig. 4. Determine the reactions at the fixed supports A and B. (18)
3. (a) For a given maximum shear stress, determine the factor by which the torque carrying capacity is increased if half-circular section is reversed from the dashed line position to the section shown in Fig. 5. The tube is 0.1" thick. (17)
- (b) A spherical gas tank has an inner radius of  $r = 1.5$  m. If it is subjected to an internal pressure of  $p = 300$  kPa, determine the required thickness if the maximum normal stress is not to exceed 12 MPa. (8)
- (c) A pressurized spherical tank is to be made of 0.5" thick steel. If it is subjected to an internal pressure of  $p = 200$  psi, determine its outer radius if the maximum normal stress is not to exceed 15 ksi. (10)
4. (a) Determine the location of  $e$  of the shear center, point  $o$ , for the thin-walled member having the cross-section shown in Fig. 6. The member segments have the same thickness  $t$ . (18)
- (b) A wood pipe having an inner diameter of 3 ft is bound together using steel hoops having a cross-sectional area of  $0.2$  in<sup>2</sup>. If the allowable stress for the hoop is  $\sigma_{\text{allow}} = 12$  ksi, determine their maximum spacing 's' along the section of pipe so that the pipe can resist an internal gauge pressure of 4 psi. Assume each hoop supports the pressure loading acting along the length  $s$  of the pipe. See Fig. 7. (17)

**CE 221**

**SECTION – B**

There are **FIVE** questions in this Section. Answer any **FOUR** questions.

5. A bracket of negligible weight shown in Fig. 8 is loaded with a vertical force  $P$  of 3 kips. Determine the deflection of point  $B$  caused by the applied vertical force. Also determine the vertical stiffness of the bracket at  $B$ . Given that cross-sectional area of members  $AB$  is  $0.205 \text{ in}^2$  and that of  $BC$  is  $0.265 \text{ in}^2$  and modulus of elasticity of the material is  $10.3 \times 10^3 \text{ ksi}$ . **(26 ¼)**
  
  6. Draw shear force and bending moment diagrams for the beam with loads shown in Fig. 9. **(26 ¼)**
  
  7. Draw shear force and bending moment diagrams for the beam with loads shown in Fig. 10. **(26 ¼)**
  
  8. Compute the maximum tensile and compressive stresses developed in the beam that is loaded and has the cross-sectional properties as shown in Fig. 11. **(26 ¼)**
  
  9. Determine the location of the shear center for the beam having the cross-sectional dimensions shown in Fig. 12. [beam section to be considered thin walled, and calculations should be based on the centerline dimensions]. **(26 ¼)**
-

~~CE221~~

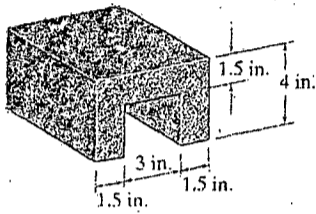
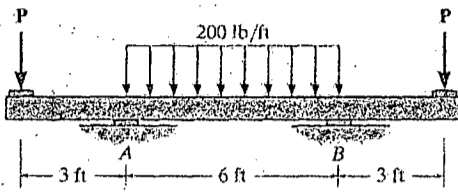

Fig. 1

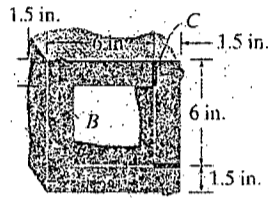
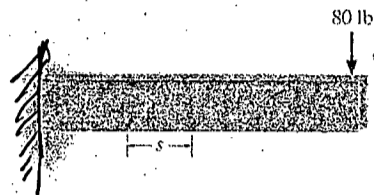

Fig. 2

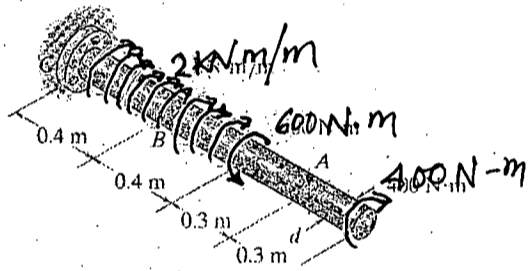

Fig. 3

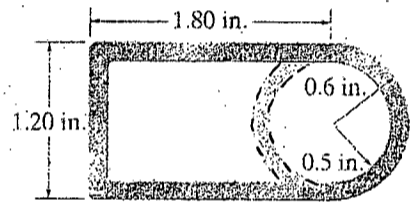

Fig. 5

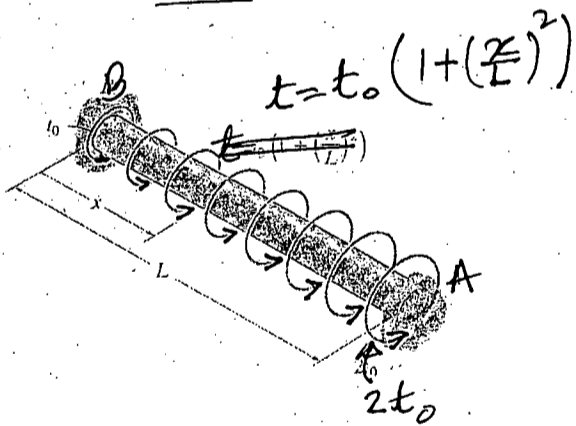

Fig. 4

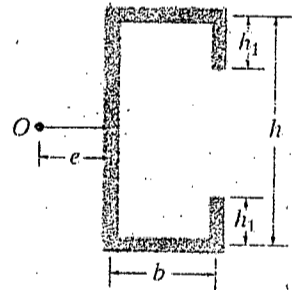

Fig. 6

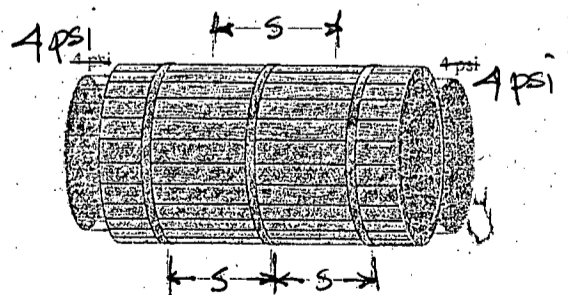

Fig. 7

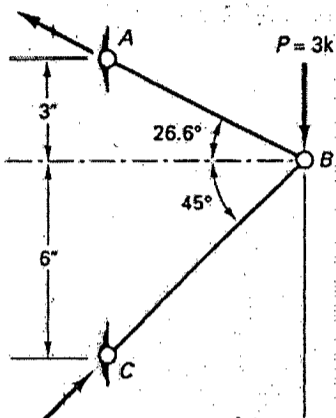

Figure 8

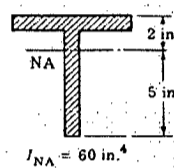
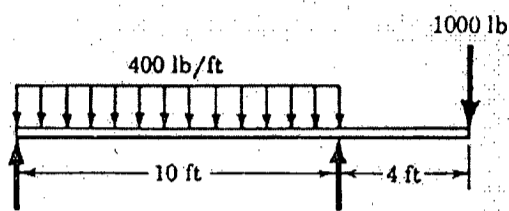

Figure 11

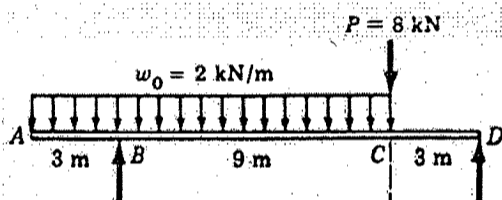

Figure 9

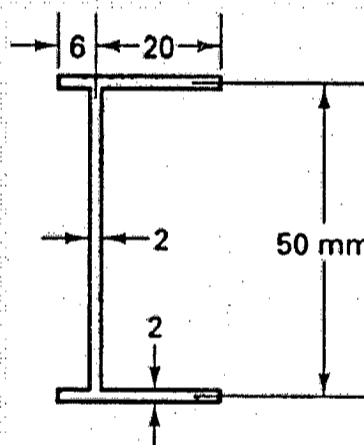

Figure 12

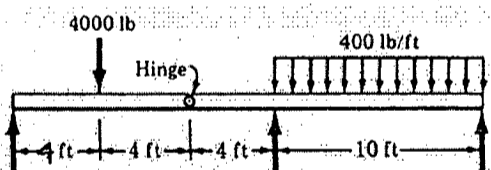

Figure 10

BANGLADESH UNIVERSITY OF ENGINEERING AND TECHNOLOGY, DHAKA

L-2/T-1 B. Sc. Engineering Examinations 2017-2018

Sub : **WRE 203** (Engineering Geology and Geomorphology)

Full Marks : 210

Time : 3 Hours

The figures in the margin indicate full marks.

USE SEPARATE SCRIPTS FOR EACH SECTION

**SECTION – A**There are **FOUR** questions in this Section. Answer any **THREE**.

1. (a) Draw an outline of the Geomorphic processes. (5)
- (b) Describe each of the following: (15)
  - (i) Weathering (ii) Mass wasting (iii) erosion (iv) diastrophism, and (v) Volcanism
- (c) What do you mean by chemical weathering processes? Describe with relevant examples all the main types of chemical weathering processes. (15)
2. (a) Define Aeolian deposits. Classify and explain various types of Aeolian deposits. (8)
- (b) Briefly describe the formation mechanisms of: (15)
  - (i) Oxbow Lakes (ii) Natural levees (iii) Deltas (iv) Evaporites (v) Kalnes and kettle holes.
- (c) Explain the different theories of meandering. (12)
3. (a) What are different characteristics of a drainage basin? Explain briefly. (8)
- (b) Explain Strahler's Method of ordering a stream network. Use this method to designate the stream orders of the stream network shown in Figure 1. (12)
- (c) Describe the geo-morphological characteristics of any three major rivers of Bangladesh. (15)

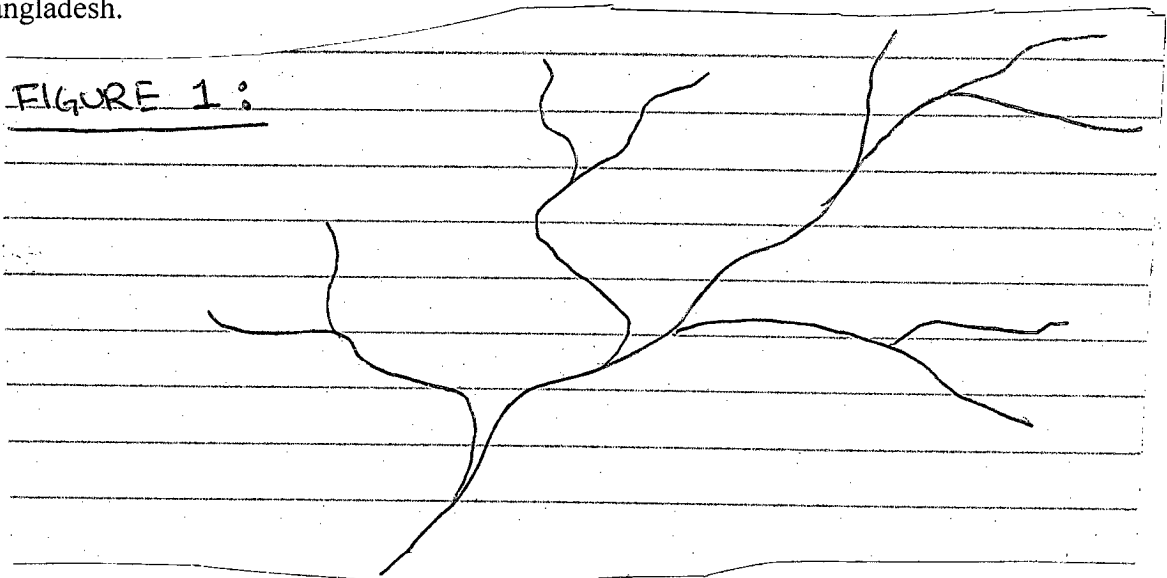

4. (a) Define and classify the littoral transport system. (5)
- (c) For the stream network shown in Figure 1. Calculate the following parameters: (15)
  - (i) Bifurcation ratio (ii) Drainage density, and (iii) Stream frequency.

Given the length of 1<sup>st</sup>, 2<sup>nd</sup>, 3<sup>rd</sup> and 4<sup>th</sup> order streams are 8 km, 25 km, 200 km and 350 km respectively. And the total area of the catchment is 600 km<sup>2</sup>.

**WRE 203**

**SECTION – B**

There are **FOUR** questions in this Section. Answer any **THREE** questions.

5. (a) Discuss the physical properties of minerals. (10)  
(b) Describe the characteristic features of the following mineral groups: (i) Biotite  
(ii) Muscovite (iii) Mica (iv) Feldspar (v) olivine. (20)  
(c) List down the attributes of a river at young stage. (5)
6. (a) Describe the concordant and discordant forms of igneous rocks with sketches. (20)  
(b) Write note on available types of textures of igneous rocks. (10)  
(c) Differentiate between the lithification and diagenesis process. (5)
7. (a) Discuss the following types of faults and folds with sketches: (i) Dip Slip Faults  
(ii) Strike slip Faults (iii) Isoclinal Folds (iv) Oblique Slip faults (12)  
(b) Differentiate between the followings: (i) primary waves and secondary waves  
(ii) Bending and Buckling (iii) Passive flow folds and Flexural flow folds. (12)  
(c) Describe the types of water erosion in details. (11)
8. (a) Discuss the physical and chemical structures of sedimentary rocks based on bedding  
geometry and weathering action. (22)  
(b) Discuss on the major causes of earthquake. (5)  
(c) Write down the types of metamorphism with specification details. (8)
-

L-2/T-1/WRE

Date : 18/09/2018

BANGLADESH UNIVERSITY OF ENGINEERING AND TECHNOLOGY, DHAKA

L-2/T-1 B. Sc. Engineering Examinations 2017-2018

Sub : **HUM 213** (Government)

Full Marks : 140

Time : 3 Hours

The figures in the margin indicate full marks.

USE SEPARATE SCRIPTS FOR EACH SECTION

**SECTION – A**

There are **FOUR** questions in this Section. Answer any **THREE**.

1. (a) Make a comparison between society and state. (11 1/3)  
(b) Discuss the merits and demerits of nationalism. (12)
2. (a) What is meant by sovereignty? Explain the characteristics of sovereignty. (11 1/3)  
(b) Discuss briefly fundamental political rights of a citizen in a state. (12)
3. (a) Who are citizens? Describe different methods of acquiring citizenship? (11 1/3)  
(b) Describe the functions of the Legislature in a state. (12)
4. Write short notes on any three (3) of the following: (23 1/3)  
(a) Democratic type of Government, (b) Written Constitution  
(c) Rule of Law, (d) Six-Point Program

**SECTION – B**

There are **FOUR** questions in this Section. Answer any **THREE** questions.

5. (a) Define good governance. Discuss the problems of good governance in developing countries. (11 1/3)  
(b) What is socialism? Describe the major challenges of socialism as political ideology. (12)
6. (a) Describe the determinants of the foreign policy of Bangladesh. (11 1/3)  
(b) Discuss the merits and demerits of the parliamentary system of government. (12)
7. (a) Discuss the major characteristics of the constitution of Bangladesh. (11 1/3)  
(b) What is local government? Discuss the functions of local government for the welfare of local people. (12)
8. (a) What do you know about UNO? Discuss the functions of the principal organs of UNO.  
(b) Write an essay on the political system of UK.

BANGLADESH UNIVERSITY OF ENGINEERING AND TECHNOLOGY, DHAKA

L-2/T-1 B. Sc. Engineering Examinations 2017-2018

Sub : **MATH 231** (Differential Equations)

Full Marks : 210

Time : 3 Hours

The figures in the margin indicate full marks.

Symbols have their usual meaning.

USE SEPARATE SCRIPTS FOR EACH SECTION

**SECTION – A**There are **FOUR** questions in this Section. Answer any **THREE**.

1. (a) Form the differential equation from the equation  $xy = Ae^x + Be^{-x} + x^2$  where A and B are arbitrary constants. (11)
- (b) Solve:  $y(1 + e^{x/y})dx + e^{x/y}(y - x)dy = 0$  (12)
- (c) Solve:  $\frac{dy}{dx} = \frac{x - y + 3}{2x - 2y + 5}$  (12)
2. (a) Find the integrating factor of the following differential equation  $(2x^3y^2 + 4x^2y + 2xy^2 + xy^4 + 2y)dx + 2(y^3 + x^2y + x)dy = 0$  and solve it. (12)
- (b) Solve:  $x \frac{dy}{dx} + y = (xy)^{3/2}$  (12)
- (c) An inductance of 2 henries and a resistance of 20 ohms are connected in a series with an e.m.f E volts. If the current is zero when  $t=0$ , find the current at end of .01 sec if  $E = 100$  volts. (11)
3. Solve the following differential equations:
- (a)  $\frac{d^2y}{dx^2} - 8\frac{dy}{dx} + 16y = x^2e^{4x} \sin 2x$  (11)
- (b)  $x^2 \frac{d^2y}{dx^2} - x \frac{dy}{dx} + 4y = \cos(\log x) + x \sin(\log x)$  (12)
- (c)  $p^2 + 2px + py + 2xy = 0$ . (12)
4. (a) Find the regular singular points of the differential equation (10)
- $$x^2(x-2)^2 \frac{d^2y}{dx^2} + 2(x-2) \frac{dy}{dx} + (x+3)y = 0$$
- (b) Solve the following differential equation in series by the method of Fröbenius: (25)
- $$9x(1-x) \frac{d^2y}{dx^2} - 12 \frac{dy}{dx} + 4y = 0.$$



**MATH 231(WRE)****SECTION – B**

There are **FOUR** questions in this Section. Answer any **THREE** questions.

5. (a) Find the partial differential equation arising from  $x^2 + ay^2 + bz^2 = 1$ . (10)
- (b) Solve  $p \sin(x+y) + q \cos(x+y) = z$ . (10)
- (c) Solve by Lagrange's method:  $(D_x^2 - D_x D_y - 2D_y^2)z = 0$ . (15)
6. (a) Solve  $(D_x^2 + 4D_x D_y + 4D_y^2)z = e^{x+2y}$ . (15)
- (b) Solve  $x^2 \frac{\partial^2 z}{\partial x^2} - 4y^2 \frac{\partial^2 z}{\partial y^2} - 4y \frac{\partial z}{\partial y} - z = x^3 y^2 \log y$ . (20)
7. (a) Give a brief description of Charpits's method. Hence solve  $z = px + qy + pq$ . (15)
- (b) Solve  $\frac{\partial U}{\partial t} = \frac{\partial^2 U}{\partial x^2}$ ,  $U(x, 0) = 3 \sin 2\pi x$ ,  $U(0, t) = 0$ ,  $U(1, t) = 0$ ; where  $0 < x < 1$ ,  $t > 0$ . (20)
8. (a) Prove that  $\frac{d}{dx} [x^v J_v(x)] = x^v J_{v-1}(x)$ . (15)
- (b) Show that  $J_{-\frac{1}{2}}(x) = \sqrt{\frac{2}{\pi x}} \cos x$ . (10)
- (c) Show that  $P_n(-1) = (-1)^n$ . (10)
-

BANGLADESH UNIVERSITY OF ENGINEERING AND TECHNOLOGY, DHAKA

L-2/T-1 B. Sc. Engineering Examinations 2017-2018

Sub : **CE 291** (Engineering Materials)

Full Marks : 210

Time : 3 Hours

The figures in the margin indicate full marks.

Symbols have their usual meaning, Assume reasonable values if any data is missing.

USE SEPARATE SCRIPTS FOR EACH SECTION

**SECTION – A**There are **FOUR** questions in this Section. Answer any **THREE**.

1. (a) Define concrete. Mention the constituent materials of concrete. Briefly describe three principal requirements for a successful concrete structure. **(2+3+6)**
- (b) Define segregation. Briefly describe three forms of segregation. Mention the remedial procedures to prevent segregation. **(2+3+2)**
- (c) Draw a typical section of ferrocement. Illustrate with neat sketches how a damp wall can be repaired with ferrocement. **(4+13)**
2. (a) Briefly describe four moisture conditions of aggregate with neat sketches. Mention the factors affecting bulk density of aggregate. **(6+3)**
- (b) Write short notes on: **(4×2=8)**
- (i) Absorption capacity (ii) Total moisture (iii) Apparent specific gravity (iv) Curing
- (c) The following masses of material are required for 1 m<sup>3</sup> of concrete. The stockpiled sand has a total moisture content of 6.5% and the stone has a total moisture content of 3.5%. Compute adjusted batch masses. **(18)**

Material	Batch mass, kg
Cement	277
Fly ash	89
SSD sand (absorption 1.0%)	779
SSD stone (absorption 2.0%)	1150
Total mixing water	185

3. (a) Describe the effects of aggregate properties on strength of hardened concrete. Illustrate graphically the relationship among w/c ratio, degree of compaction, compressive strength and workability of concrete. **(6+4)**
- (b) Design compressive strength of concrete of a structure is 4000 psi. The test results of concrete are as follows: **(10)**
- Day 1: (2500 psi, 4500 psi), (3000 psi, 4680 psi), (4200 psi, 4520 psi)
  - Day 2: (3500 psi, 4050 psi), (3800 psi, 3900 psi)
  - Day 3: (4100 psi, 4360 psi)
  - Day 4: (4500 psi, 4150 psi)
- In accordance with ACI Code, are these results satisfactory?
- (c) Differentiate between wood and timber. Mention the advantages of using timber. **(2+5)**
- (d) Define seasoning of timber. Briefly describe the methods of seasoning. **(2+6)**

**CE 291**

4. (a) Compare among cast iron, wrought iron, mild iron and hard iron on the basis of uses. (8)
- (b) Define vulcanization. Briefly describe the advantages of vulcanization. Mention the uses of rubber. (2+3+2)
- (c) For the loading history shown below, draw the likely strain response of:  
 (i) Elastic; (ii) Plastic; (iii) Elasto-Plastic and (iv) Elasto-Visco-Plastic material. Assume, equal time interval, i.e.,  $\Delta t = t_1 - t_0 = t_2 - t_1 = t_3 - t_2 = t_4 - t_3$ . (20)

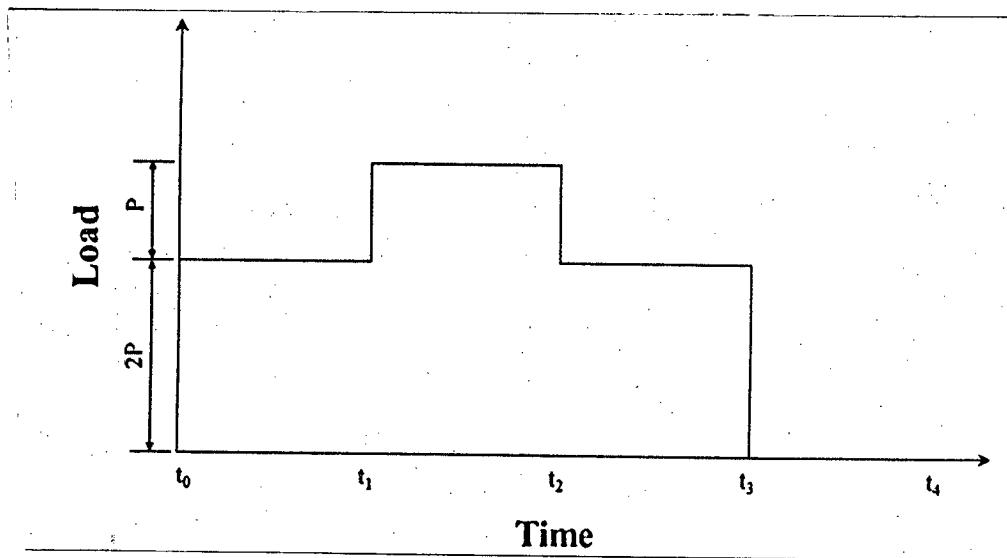

**SECTION – B**

There are **FOUR** questions in this Section. Answer any **THREE** questions.

5. (a) Write down the functions of  $C_3A$ ,  $C_2A$ ,  $C_2S$ , and  $C_4AF$  in cement. (3 ½ × 4 = 14)
- (b) Explain the hydration of aluminates in Portland cement when the  $C_3A$  is high but gypsum is very low. (5)
- (c) Define initial setting time and final setting time. Briefly explain the procedure of determining the initial setting time. (3+5=8)
- (d) Differentiate between the followings. (4×2=8)
- (i) Rapid hardening cement and quick setting cement (ii) Flash setting and false setting
6. (a) Briefly describe the field test methods to identify silt and clay, salt and organic matter in sand. (3×3=9)
- (b) Write down ingredients and purpose of the light weight mortar and fire resistant mortar. (6)
- (c) From the sieve analysis data of the sand sample below, determine the FM of the sample. Is this sample a well graded aggregate? (20)

Sieve size (mm)	4.75	2.36	1.18	0.6	0.42	0.3	0.15	0.075	PAN
Materials retained (gm)	9	20	30	90	153	134	50	12	2

**CE 291**

7. (a) Discuss the harmful effects on bricks if lime and alkalis are present in brick earth. **(10)**  
(b) Write down the relative advantages and disadvantages of the intermittent kiln and Hoffman kiln for brick manufacturing process. **(6)**  
(c) What is “Frog Mark” in brick? What are the purpose of frog marks? **(6)**  
(d) Define slaking. Write down the definition, properties, and use of fat lime and hydraulic lime. **(3+10=13)**
8. (a) List the requirements of a good heat insulating material and noise insulating material. **(10)**  
(b) Describe the functions of silica, lime, and manganese dioxide in glass. **(9)**  
(c) Write short notes on the followings: **(4×4=16)**  
(i) Field tests of bricks (ii) Crown glass (iii) Gauged mortar (iv) Soundness of aggregate.
-